

RAFALE

vehicle user manual





Welcome aboard your vehicle

This user manual contains the information required:

- for you to familiarise yourself with your vehicle, to use it to its best advantage and to fully benefit from all the functions and the technical developments it incorporates.
- to ensure that it always gives the best performance by following the simple, but comprehensive advice concerning regular maintenance.
- to enable you to deal quickly with minor faults not requiring specialist attention.

It is well worth taking a few minutes to read this manual to familiarise yourself with the information and guidelines it contains about the vehicle and its functions and new features. If certain points are still unclear, our Network technicians will be only too pleased to provide you with any additional information.

For guidance, please see the following symbols:

 and  Visible on the vehicle, they show that you should consult the manual to find detailed information and/or limits on operations in respect of equipment on your vehicle.

→ anywhere in the manual indicates a transfer to a page.



anywhere in the manual indicates a hazard, danger or a safety recommendation.

The description of the models given in this manual is based on the technical specifications at the time of writing. **The manual covers all items of equipment (both standard and optional) available for these models, but whether or not these are fitted to the vehicle depends on the version, the options selected and the country where the vehicle is sold.**

This manual may also contain information about items of equipment to be introduced later in the model year.

The diagrams in the user manual are provided as examples only.

Enjoy driving your new vehicle.

Translated from French. Copying or translation, in part or in full, is forbidden unless prior written permission has been obtained from the car manufacturer.

CONTENTS

Welcome aboard your vehicle	4	Lighting and signals.....	143
Exterior	4	Audible and visual signals	151
Passenger compartment	6	Wiper	152
Driver's position	8	Fuel tank.....	155
Driving aids	10	Driving	159
Safety on board	12	Running in.....	159
Identifying a vehicle - Labels	14	Starting, stopping the engine	160
The engine compartment (routine maintenance).....	16	Gear control.....	163
Breakdown recovery	18	Regenerative braking system	167
The E-Tech full hybrid vehicle.....	20	Special features of petrol engines	169
The E-Tech plug-in hybrid vehicle	22	Parking brake.....	171
Getting to know your vehicle	24	Environment.....	176
E-tech full hybrid vehicle (HEV).....	24	Maintenance and antipollution advice	177
E-Tech plug-in hybrid vehicle (PHEV)	29	Driving advice, eco-driving	178
Card	50	Tyre pressure loss warning.....	183
Digital key	58	Driver correction devices and aids	187
Doors and opening elements.....	61	Additional driving aid functions	195
Facial recognition.....	72	Speed limiter.....	248
Front seats	73	Adaptive cruise control	252
Rear seats	78	Parking aids	268
Seat belts.....	80	Emergency call	298
Additional safety devices	85	Your comfort	301
Child safety	94	Multi-Sense.....	301
Child seats	100	Air vents, heating and air conditioning.....	303
Child safety: deactivating, activating the front passenger airbag.....	112	Multimedia equipment	315
Driving position	115	Passenger compartment equipment.....	317
Trip computer.....	120	Passenger compartment storage, fittings	322
Warning lights	134	Transporting objects	328
Steering	139	Maintenance	331
Rear view	141	Accessing the engine, levels	331

CONTENTS

Battery	339
Cleaning.....	340
Practical advice.....	344
Tyres	344
Breakdown recovery	356
Headlights, lights: replacing bulbs	361
Wiper blades: replacement.....	364
Fuses	365
Installation and use of accessories.....	368
Operating faults	370
Technical specifications	375
Information about the vehicle	375
Replacement parts and repairs	383
Service sheets	384
Anticorrosion check	390

EXTERIOR

1

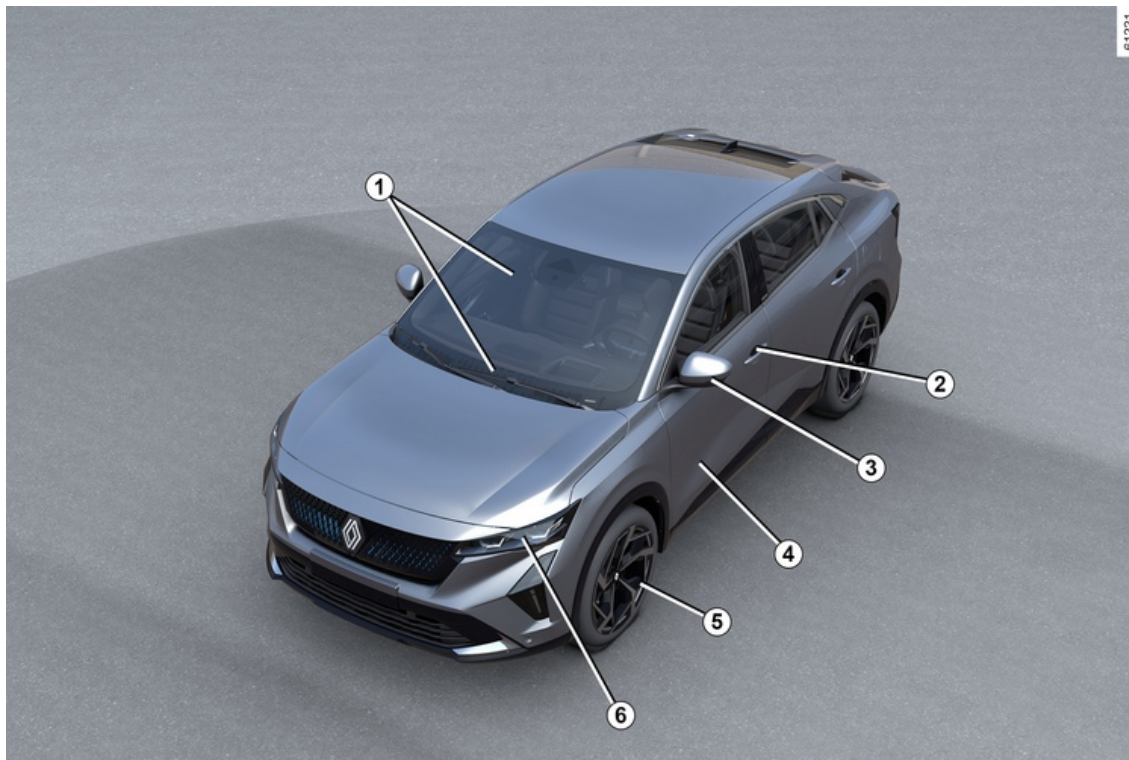

EXTERIOR

1. Electric windows → 317

Window wipers → 152

Demisting → 307

2. → 50 card

Locking/unlocking the doors → 62

3. Rear view mirrors → 141

4. Bodywork maintenance → 340

5. Tyres → 344

6. Lights: operation → 143

Lights: replacement → 361

PASSENGER COMPARTMENT

1

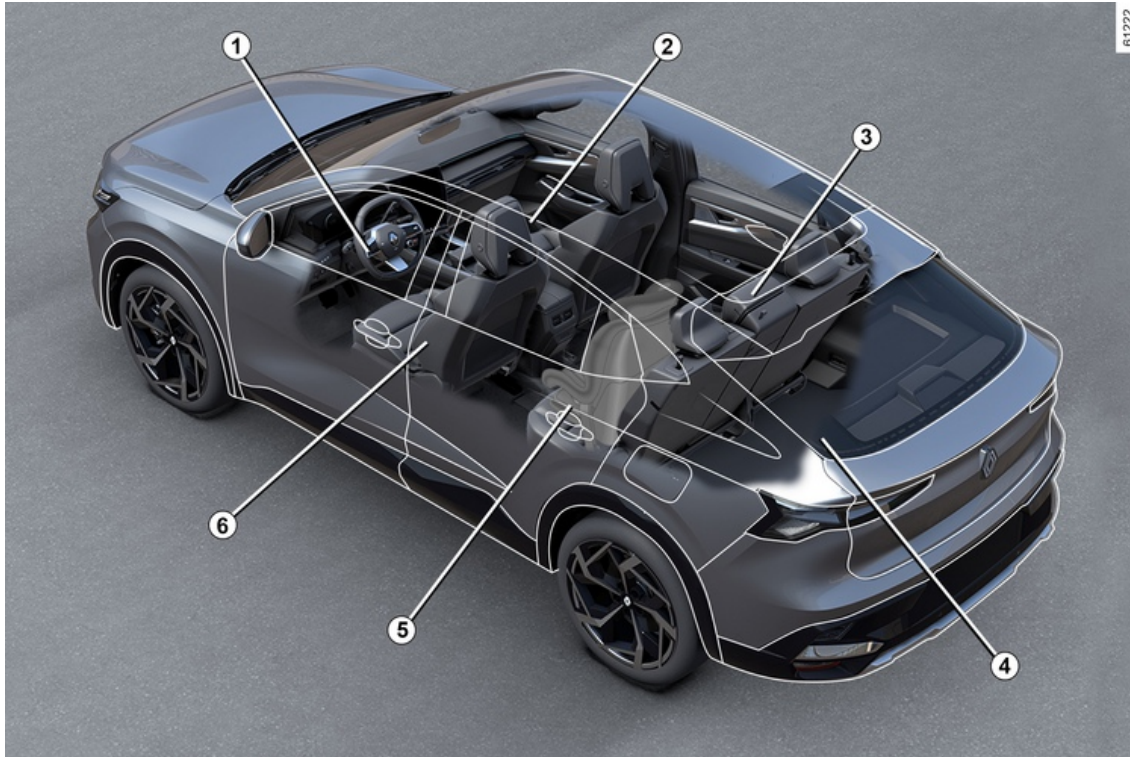

6 - Welcome aboard your vehicle

PASSENGER COMPARTMENT

1. Adjusting your driving position → **80**
2. Passenger compartment storage/fittings → **322**
3. Rear headrests → **78**
Rear bench seat → **78**
4. Luggage compartment storage/fittings → **328**
5. Child safety → **94**
6. Front headrests → **73**
Front seats → **73**

DRIVER'S POSITION

1

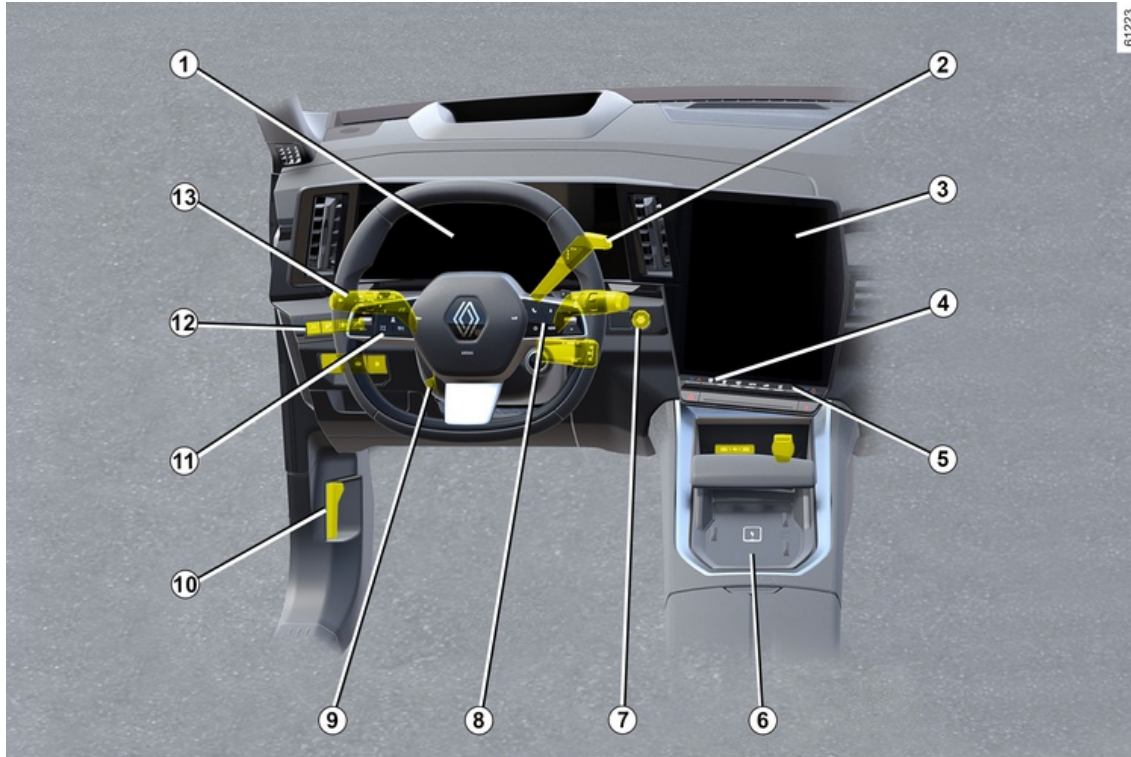

DRIVER'S POSITION

1. Instrument panel → 134
2. Gear lever → 163
3. Multimedia screen → 315
4. Heated seat(s) → 74 or → 75
5. Heating system/air conditioning → 303
6. Telephone charging zone → 322
7. Engine start/stop button → 160
8. Trip computer controls → 120
9. Steering wheel adjustment → 139
10. Bonnet release → 331
11. Speed limiter → 248
Stop and Go adaptive cruise control → 252
12. Electronic parking brake → 171
13. Exterior lighting → 143

DRIVING AIDS

1

61224



DRIVING AIDS

- ABS (anti-lock braking system) → **187**
- ESC (electronic stability control) → **188**
- Braking assistance
- Hill Start Assist → **190**
- Autohold → **174**
- Lane departure prevention → **196**
- Emergency lane departure prevention → **203**
- Active emergency braking → **220**
- Active emergency braking in reverse gear → **245**
- Blind spot warning → **210**
- Safe distance warning → **216**
- Road sign detection → **229**
- Speed limiter → **248**
- Active Driver Assist → **232**
- Park Assist → **268**
- Reversing camera → **274**
- 360° camera → **282**
- Parking exit warning → **290**
- Park Assist → **277**
- Tyre pressure loss warning → **183**

SAFETY ON BOARD

1

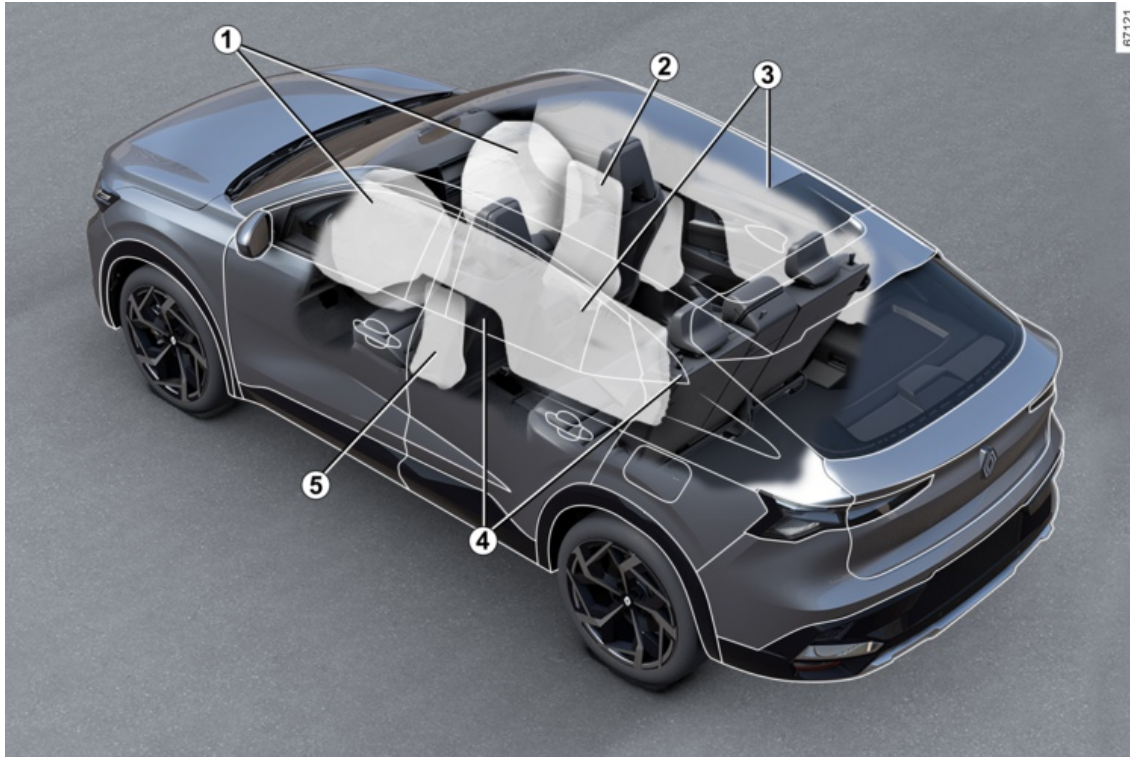

SAFETY ON BOARD

1. Airbags Front → 85
2. Airbags Central → 91
3. Airbags Curtain → 91
4. Seat belts → 80
5. Airbags side → 90

IDENTIFYING A VEHICLE - LABELS

1

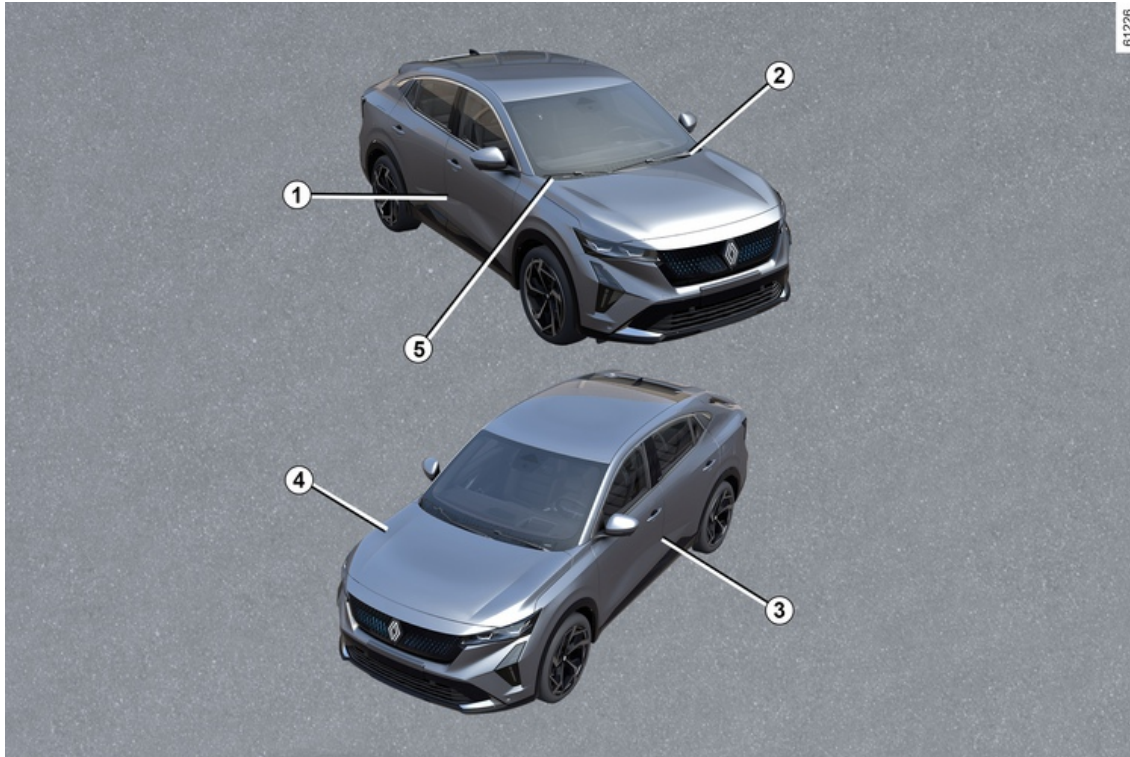

IDENTIFYING A VEHICLE - LABELS

1. Vehicle identification plate → **375**
2. Vehicle identification number reminder → **375**
3. Tyre pressure label → **346**
4. Engine identification plate → **376**
5. Technical information for the emergency services → **375**

THE ENGINE COMPARTMENT (ROUTINE MAINTENANCE)

1

611227

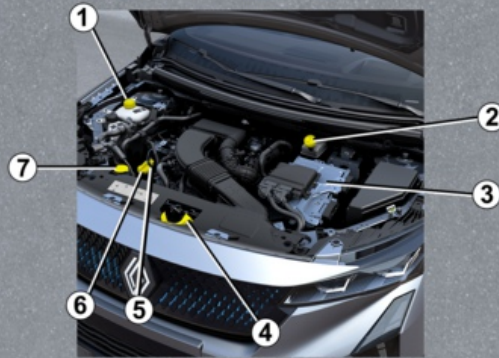

THE ENGINE COMPARTMENT (ROUTINE MAINTENANCE)

1. Coolant → 335
2. Brake fluid → 337
3. Remote battery terminals → 339, → 24, → 29, → 357
4. Opening the bonnet → 331
5. Engine oil dipstick → 332
6. Engine oil filler cap → 332
7. Screen washer fluid → 338

BREAKDOWN RECOVERY

1

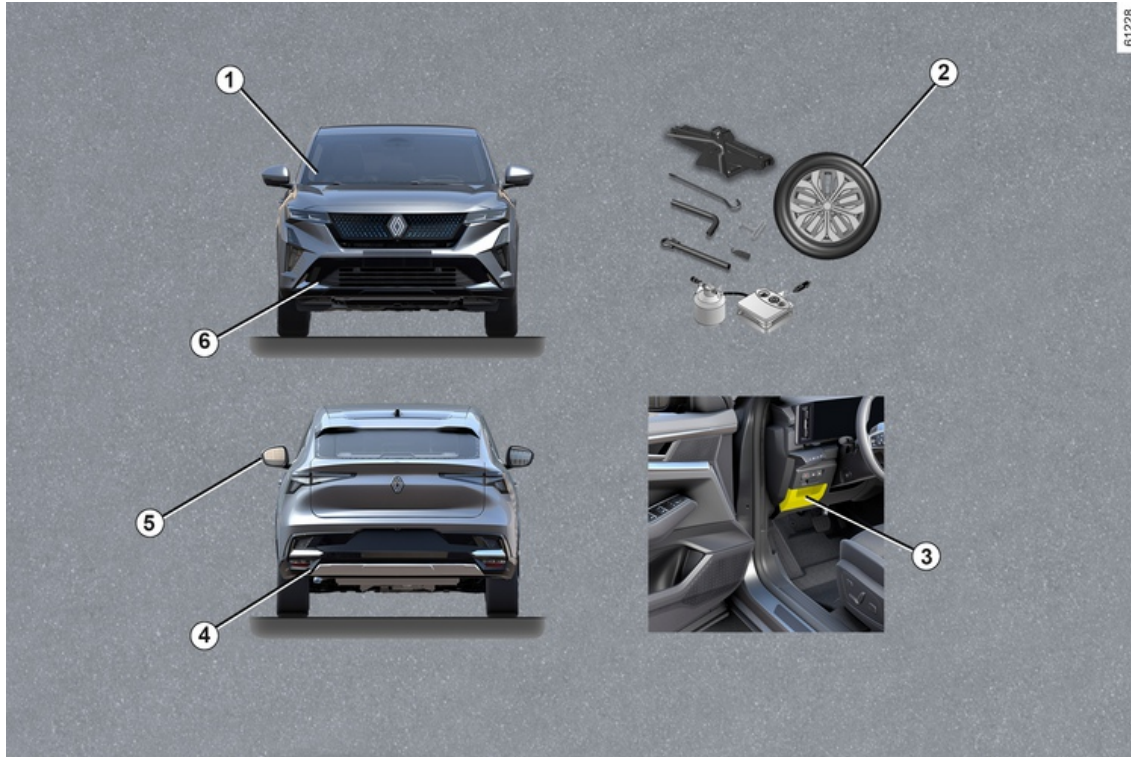

BREAKDOWN RECOVERY

1. Replacing windscreen wiper blade(s) → **364**
2. Puncture: → **350** tools, emergency spare wheel → **352**, changing a wheel → **354**, tyre inflation kit → **347**
3. Fuses → **365**
4. Rear towing point → **356**
5. Replacement of the direction indicator lights → **361**
6. Front towing point → **356**

THE E-TECH FULL HYBRID VEHICLE

1

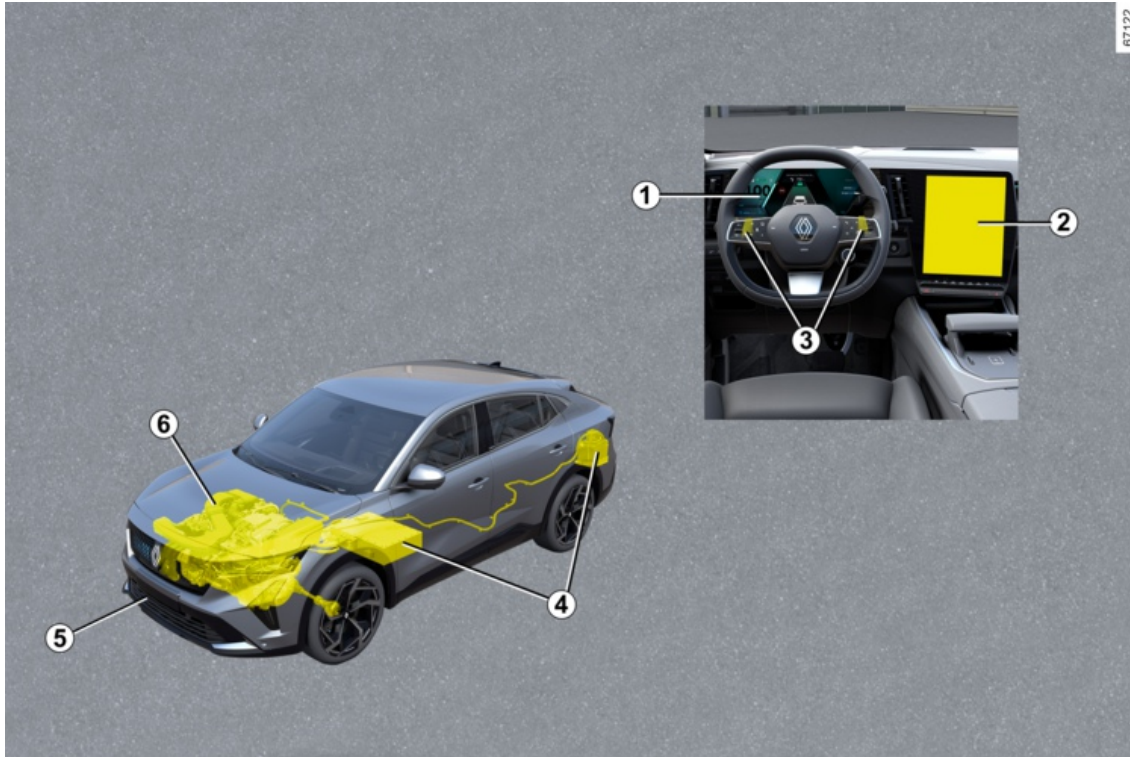

67122

THE E-TECH FULL HYBRID VEHICLE

E-Tech full hybrid vehicle system: introduction → **24**

E-Tech full hybrid vehicle system: important recommendations → **28**

1. Warning lights → 134

Displays and indicators → **127**

Power meter → **180**

2. Parking aids → 268

3. Regenerative braking change paddles → 167

4. Batteries → 24

5. Towing, breakdown recovery → 356

6. Coolant → 337

THE E-TECH PLUG-IN HYBRID VEHICLE

1

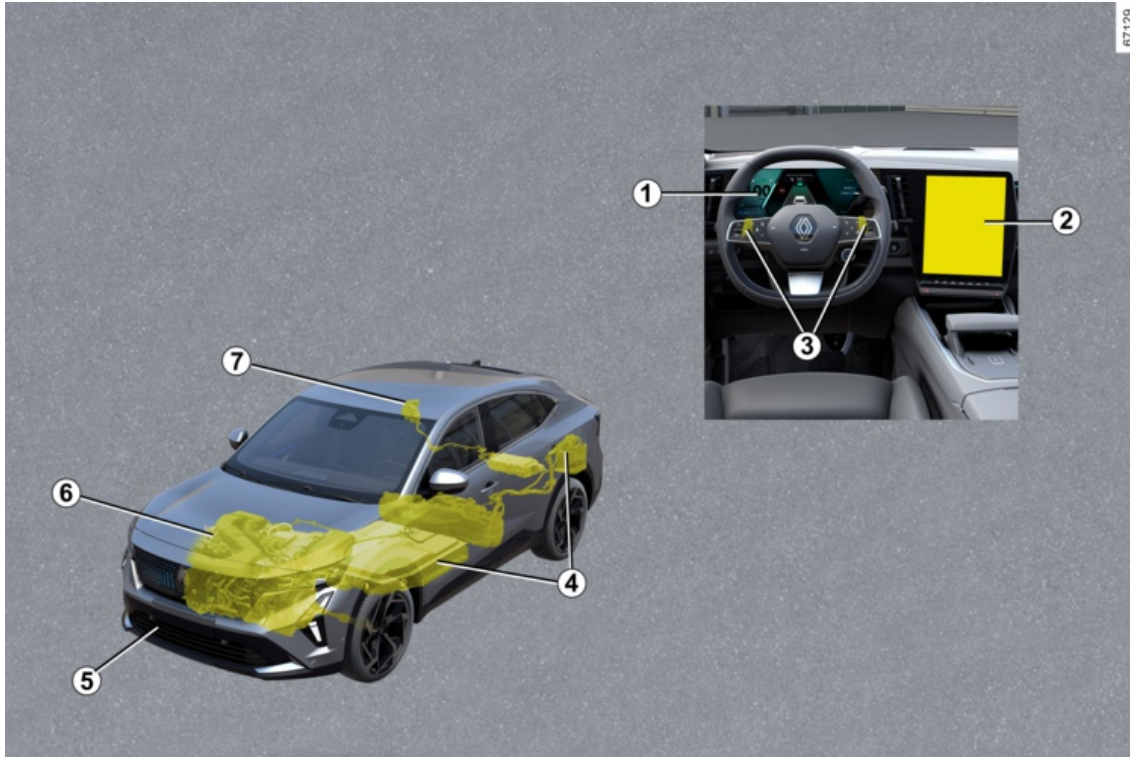

THE E-TECH PLUG-IN HYBRID VEHICLE

E-Tech plug-in hybrid vehicle system: introduction → **29**

E-Tech plug-in hybrid vehicle system: important recommendations → **35**

E-Tech plug-in hybrid vehicle system: charging → **37** → **48**

1. Warning lights → 134

Displays and indicators → **127**

Power meter → **180**

2. Automatic parking → 277

3. Regenerative braking change paddles → 167

4. Batteries → 29

5. Towing, breakdown recovery → 356

6. Coolant → 331

7. Charging connection → 37

E-TECH FULL HYBRID VEHICLE (HEV)

Introduction

2



E-TECH FULL HYBRID VEHICLE (HEV)

1. "12 Volt" battery
2. Orange electrical power cables
3. 400 V traction battery
4. Electric motor
5. Combustion engine

The E-Tech full hybrid vehicle system uses an electric motor to improve the performance of the combustion engine (acceleration, starting, etc.).

The vehicle has more acceleration torque available while consuming less fuel.

The vehicle may also move in all-electric operating mode without any assistance from the combustion engine. The vehicle uses energy stored in the "400 V" traction battery.

Batteries

The E-Tech full hybrid vehicle is equipped with two types of battery:

- a "400 V" traction battery;
- a secondary "12 V" battery.

"400 V" traction battery

This battery, located underneath the rear floor, stores the energy required for the electric motor to operate correctly.

As with any battery, it discharges when it is used. The traction battery is charged:

- during the vehicle deceleration phases;
- when the combustion engine starts automatically in order to act as a generator.

Your vehicle range in electric operating mode depends on the charge level of the traction battery, and also on your driving style and the components consuming energy (air conditioning, heating system etc.).

In the event of traction battery discharge, the combustion engine alone moves the vehicle until the traction battery is sufficiently recharged.

The vehicle's air conditioning system is used to cool the traction battery. To preserve the lifetime of your traction battery, have your air conditioning system checked by a qualified professional. Especially if you notice a reduction in air conditioning performance.

If your vehicle is parked for a long time, start the engine at regular intervals (about once a month) and check

that the  warning light is displayed in blue on the instrument panel. If this happens, the battery needs to be recharged: leave the engine on until

the warning light is displayed in blue → 127.

Failure to do so may result in damage to the traction battery and make it impossible to start the vehicle.



The E-Tech full hybrid vehicle electrical system uses approximately 400 V of direct current.

This system can get hot during and after switching off the ignition. Respect warning messages given on the labels in the vehicle.

All operations on or modifications to the "400 V" electrical system (components, cables, connectors, traction battery) are strictly prohibited due to the risks they present to your safety. Call an approved dealer.

The risk of serious burns or electric shocks can lead to death.

"12 V" battery

The "12 V" battery, located in the luggage compartment, supplies the energy required to open/close the vehicle and to operate the equipment.

E-TECH FULL HYBRID VEHICLE (HEV)

Note: the "12 V" battery does not help to start the combustion engine. This is provided by the E-Tech full hybrid system.

"400 V" electrical circuit

A



The **A** symbol identifies the electrical elements in your vehicle which may present safety risks.

61587



61556

The "400 V" electrical circuit can be recognised by orange cables **6** and parts bearing the  symbol.

Noise

The E-Tech full hybrid vehicles are particularly quiet in the electric operating mode. You will not yet necessarily be used to it, and neither will other road users. It is difficult for them to hear your vehicle when it is moving.

As the electric motor is silent, you will hear noises that may seem unusual (aerodynamic noises, tyres, etc.) as well as noises due to the operation of the E-Tech full hybrid system (e.g. cooling of the traction battery).



As your E-Tech full hybrid vehicle is silent, when leaving it always engage the gear in P position, apply the parking brake and switch off the ignition.
RISK OF SERIOUS INJURY.

Pedestrian horn

The pedestrian horn enables you to warn others of your presence – especially pedestrians and cyclists. In electric operating mode, the system is activated automatically. The sound is emitted when the vehicle speed is between approximately 1 and 19 mph (1 and 30 km/h).

For further information on the pedestrian horn, refer to the multimedia instructions.

In the event of a pedestrian horn mal-

function, the  warning light is illuminated on the instrument panel accompanied by the "Exterior sound fault" message.

Consult an approved dealer.

E-TECH FULL HYBRID VEHICLE (HEV)

Operation

The E-Tech full hybrid system selects the combustion engine and/or the electric engine according to the driving style (smooth, sporty, etc.), the traffic conditions and driving mode selected → 301.

Bad weather, flooded roads:



Do not drive through floods if the depth of water is above the lower edge of the wheel rims.

Energy flow



Depending on the driving mode selected, the various energy flows are shown on the instrument panel.

These are energy flows between:

- **B**: the combustion engine;
- **C**: the electrical assembly (traction battery and electric motor).

The colour of flows varies:

- blue: electrical energy;
- white: energy produced by the combustion engine.



Regenerative braking level warning light *D*

When you lift your foot off the accelerator pedal or when you press on the brake pedal, the electric motor and/or the regenerative braking system convert(s) the energy produced by the vehicle deceleration into electric energy. For more information → 24.

This is used to brake the vehicle and recharge the traction battery.

All-electric driving mode

The **EV** warning light is displayed on the instrument panel to inform you that the E-Tech full hybrid system is using only the electrical assembly to power the vehicle movement.



The engine brake should under no circumstances be used as a substitute for the brake pedal.

Note: when the traction battery level is low, the vehicle automatically switches to hybrid mode and the combustion

engine starts: the **EV** disappears from the instrument panel to confirm this.

E-TECH FULL HYBRID VEHICLE (HEV)

Important recommendations

2



Please read these instructions carefully. Failure to follow these instructions may lead to **a risk of fire, serious injury or electric shocks which could result in death.**

In the event of an accident or impact

In the event of an accident or an impact to the underside of the vehicle (e.g. striking a post, raised kerb or other street furniture) the electric circuit or the traction battery may be damaged.

Have the vehicle checked by an authorised dealer.

Never touch the "400 V" components or orange cables which are exposed and visible inside or outside the vehicle.

In the event of serious damage to the traction battery, leaks may occur:

- never touch liquids (fluids, etc.), coming from the traction battery;
- in the event of contact with the body, wash the affected area with plenty of water and consult a doctor as soon as possible.

In the event of fire

In the event of a fire, leave the vehicle immediately and evacuate it, then contact the emergency services, informing them that this is a hybrid vehicle.

If you have to intervene, only use ABC or BC extinguishing agents that are suitable for extinguishing fires on electrical systems. Do not use water or other extinguishing agents.

In the event of damage to the electrical circuit, please call an authorised dealer.

All towing operations

Refer to the paragraph entitled "Towing, breakdown recovery" → 356.

Washing the vehicle

Never wash the engine compartment and "400 V" traction battery using a high-pressure washer.

This risks damaging the electric circuit.

Risk of electric shock and a risk to life.

E-TECH PLUG-IN HYBRID VEHICLE (PHEV)

Introduction

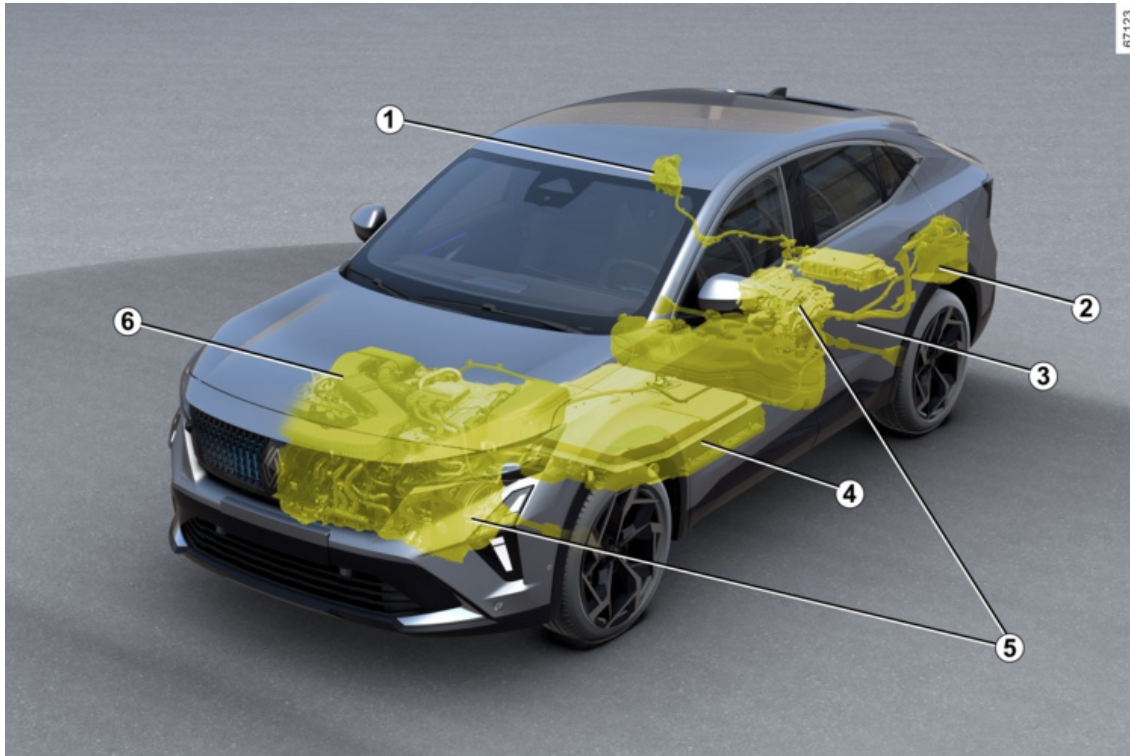

E-TECH PLUG-IN HYBRID VEHICLE (PHEV)

1. Electric charging connection
2. Secondary 12 V battery
3. Orange electrical power cables
4. 400 V traction battery
5. Electric motors
6. Combustion engine

The E-Tech plug-in hybrid vehicle system uses electric motors to drive the vehicle.

Electric motors are assisted by the combustion engine if the energy or electrical power is insufficient.

The vehicle may also move in all-electric operating mode without any assistance from the combustion engine. The vehicle uses energy stored in the "400 V" traction battery.

There are several ways to recharge the traction battery:

- during the braking or deceleration phases;
- using its combustion engine which can be used as a generator;
- directly on a recharging terminal or a domestic power socket.

Connected services

Your rechargeable hybrid vehicle is equipped with connected services that provide information and/or control:

- your vehicle's charging status with low battery warning;
- the traction battery charging programming, based on certain choices on offer;
- remaining vehicle range;
- ...

You can access these services using:

- external digital devices (mobile phone, tablet, etc.);
- the vehicle multimedia screen.

For more information, refer to the multimedia equipment instructions or contact an Approved Dealer.



You can subscribe to a connected service or extend it at any time by consulting an authorised dealer.

Batteries

The rechargeable hybrid vehicle is equipped with two types of battery:

- a "400 V" traction battery;
- secondary 12 V battery.

"400 V" traction battery

This battery stores the energy required to operate electric motors. As with any battery, it discharges when used, and must be regularly recharged:

- during deceleration phases;
- with the combustion engine starting automatically, even at idle speed, to act as a generator and maintain the traction battery charging level;
- on a power outlet or a recharging terminal using the charging cable.

You do not have to wait until the traction battery hits the reserve level in order to recharge it.

Charging times vary depending on the type of specific wall unit socket or public terminal you connect to.

Your vehicle range depends on the traction battery charge level as well as your driving style ➔ **178** and the components consuming energy (air conditioning, heating system, etc.).

In the event of traction battery discharge, the combustion engine alone moves the vehicle until the traction battery is sufficiently recharged.

The vehicle's air conditioning system is used to cool the traction battery. To preserve the lifetime of your traction battery, have your air conditioning system checked by a qualified professional. Especially if you notice a reduction in air conditioning performance.

Secondary 12 V battery

The second battery on your vehicle is a secondary 12 V battery: this supplies the energy required to operate vehicle

E-TECH PLUG-IN HYBRID VEHICLE (PHEV)

equipment (lights, windscreen wipers, braking assistance, etc.).

(A)



The **A** symbol identifies the electrical elements in your vehicle which may present safety risks.

61607

"400 V" electrical circuit



61556

The "400 V" electrical circuit can be recognised by orange cables **7** and parts bearing the  symbol.



The drive system of the rechargeable hybrid vehicle uses direct current of approximately 400 V.

This system can get hot during and after switching off the ignition. Observe the warning messages on the labels in the vehicle. All operations on or modifications to the 400 V electrical system (components, cables, connectors, traction battery) are strictly prohibited due to the risks they present to your safety. Call an approved dealer.

The risk of serious burns or electric shocks can lead to death.

Driving

As with any car with an automatic gearbox, you will have to get used to not using your left foot, and not using this foot to brake.

The hybrid system selects the combustion engine and/or the electric motors, depending on the driving conditions and the driving mode selected.

When driving, if you lift your foot off the accelerator pedal or depress the brake

E-TECH PLUG-IN HYBRID VEHICLE (PHEV)

pedal, the motor generates electrical current during deceleration and this energy is used to brake the vehicle and recharge the battery ➔ 178.

Bad weather, flooded roads:



Do not drive through floods if the depth of water is above the lower edge of the wheel rims.



The engine brake should under no circumstances be used as a substitute for the brake pedal.



Driver obstruction

On the driver's side, only use mats suitable for the vehicle, attached with the pre-fitted components, and check the fitting regularly. Do not lay one mat on top of another.

There is a risk of wedging the pedals

Noise

Rechargeable hybrid vehicles are particularly quiet in all-electric operating

mode. You will not yet necessarily be used to it, and neither will other road users. It is difficult for them to hear the vehicle when it is moving.

As electric motors are silent, you will hear noises that you are not used to hearing (aerodynamic noises, tyre noise, etc.)

Each time the ignition is switched off, the ventilation will be switched off after about ten seconds.



As your rechargeable hybrid vehicle is silent, before you get out, switch off the engine with the brake pedal pressed and check that the electronic parking brake is correctly applied.

RISK OF SERIOUS INJURY

Pedestrian horn

The pedestrian horn enables you to warn others of your presence – especially pedestrians and cyclists.

When the engine is started, the pedestrian horn is activated automatically. The sound is triggered when the vehicle speed is below approximately 19 mph (30 km/h).

For further information on the pedestrian horn, refer to the multimedia instructions.

In the event of a fault with the pedestrian

horn, the  warning light is displayed on the instrument panel, accompanied by the "Exterior sound fault" message.

Consult an approved dealer.

Operation

The E-Tech plug-in hybrid system selects the combustion engine and/or the electric motors according to the driving style (smooth; sporty, etc.), the traffic conditions and the driving mode selected ➔ 301.

E-TECH PLUG-IN HYBRID VEHICLE (PHEV)

Energy flow



Depending on the driving mode selected, the various energy flows are shown on the instrument panel.

These are energy flows between:

- **B**: the combustion engine;
- **C**: the electrical assembly (traction battery and electric motors).

The colour of flows varies:

- blue: electrical energy;
- white: energy produced by the combustion engine.



Regenerative braking level warning light **D**

When you lift your foot off the accelerator pedal or when you press on the brake pedal, the electric motors and/or the regenerative braking system convert(s) the energy produced by the vehicle deceleration into electrical energy.

This is used to brake the vehicle and recharge the traction battery.

All-electric driving mode

The **EV** warning light is displayed on the instrument panel to inform you that the E-Tech plug-in hybrid system

is using only the electrical assembly to power the vehicle movement.

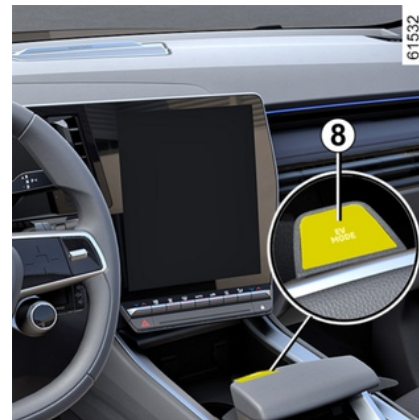

When the hybrid system is using the combustion engine with or without the electric motor to power the vehicle movement, it is possible to manually switch to all-electric mode.

Press switch **8** as many times as necessary. The "Electric" message is displayed accompanied by the **EV**

warning light on the instrument panel.

Otherwise, the "EV unavailable" message is displayed on the instrument panel.

Note: in all-electric mode, the maximum speed is limited.

E-TECH PLUG-IN HYBRID VEHICLE (PHEV)

Press switch **8** as many times as required to exit "Electric" mode.

The "Electric" message disappears

along with the **EV** warning light from the instrument panel.

Note: when the traction battery level is low, the vehicle automatically switches to hybrid mode and the combustion

engine starts: the **EV** disappears from the instrument panel to confirm this.



The engine brake should under no circumstances be used as a substitute for the brake pedal.

Maintaining the traction battery charge level "E-save"

This mode enables you to maintain a sufficient charge level in the traction battery in anticipation of certain road types (e.g. mountain road, long uphill section of motorway, etc.). It also serves to maintain range for future journeys in all-electric mode.

Note: if you are towing a trailer, it is strongly recommended that you charge the traction battery and engage

"E-Save" mode from the outset, especially in the event of a rough road surface.

Activation, deactivation of "E-Save" mode



To activate this mode, with the engine started, press switch **8** as many times as necessary.

The "E-Save" message is displayed on the instrument panel.

Otherwise, the "Battery Save unavailable" message is displayed on the instrument panel.

To deactivate the mode, press the switch **8** as many times as necessary to exit "E-Save" mode. The "E-Save"

message disappears from the instrument panel.

E-TECH PLUG-IN HYBRID VEHICLE (PHEV)

Important recommendations



Please read these instructions carefully. Failure to follow these instructions may lead to **a risk of fire, serious injury or electric shocks which could result in death.**

In the event of an accident or impact

In the event of an accident or an impact to the underside of the vehicle (e.g. striking a post, raised kerb or other street furniture) the electric circuit or the traction battery may be damaged.

Have the vehicle checked by an authorised dealer.

Never touch the "400 V" components or orange cables which are exposed and visible inside or outside the vehicle.

In the event of serious damage to the traction battery, leaks may occur:

- never touch liquids (fluids, etc.), coming from the traction battery;
- in the event of contact with the body, wash the affected area with plenty of water and consult a doctor as soon as possible.

In the event of an impact, even slight, against the charging flap and/or valve, have them checked by an authorised dealer as soon as possible.

In the event of fire

In the event of fire, make everyone evacuate the vehicle immediately and contact the emergency services, informing them that this is an electric vehicle.

If you have to intervene, only use ABC or BC extinguishing agents that are suitable for extinguishing fires on electrical systems. Do not use water or other extinguishing agents.

In the event of damage to the electrical circuit, please call an authorised dealer.

All towing operations → 356

Washing the vehicle

Never wash the engine compartment, the charging connection or the traction battery with a high-pressure jet.

This risks damaging the electric circuit.

Never wash the vehicle while it is charging. Never wash the charging cable while the vehicle is charging. Never wash the charging cable and the charging cable plug while the cable is not connected, in order to prevent corrosion of the charging pins.

E-TECH PLUG-IN HYBRID VEHICLE (PHEV)

Risk of electric shock and a risk to life.

2

E-TECH PLUG-IN HYBRID VEHICLE (PHEV)

Charging

Schematic diagram



61529

E-TECH PLUG-IN HYBRID VEHICLE (PHEV)

1 Specific wall socket or recharging terminal

2 Charging cable

3 Electric charging connection (passenger side)



If you have any questions regarding the equipment needed for charging, please ask an authorised dealer.

E-TECH PLUG-IN HYBRID VEHICLE (PHEV)

Important recommendations for charging



Important recommendations for charging your vehicle

Please read these instructions carefully. Failure to follow these instructions may lead to **a risk of fire, serious injury or electric shocks which could result in death.**

Charging

Do not do anything to the vehicle during charging (washing, working in the engine compartment, etc.).

In the event of the presence of water, signs of corrosion or foreign bodies in the charging cord connector or in the vehicle charging socket, do not charge the vehicle. **Fire hazard.**

Do not attempt to touch the cord contacts, the domestic socket or the vehicle charging socket, or introduce objects into them.

Never plug the charging cord into an adapter, multiple socket or extension lead.

The use of generators is prohibited.

Do not remove or change the vehicle charging socket or the charging cord. **Fire hazard.**

Do not modify or perform any action on the installation during charging.

In the event of an impact, even slight, against the charging flap or valve, have them checked by an authorised dealer as soon as possible.

Take care of the lead: do not tread on it, immerse it in water, pull on it or let anything knock against it.

Check regularly that the charging lead is in good condition.

In the event of damage to the charging lead (corrosion, browning, cuts, etc.), to the unit or to the vehicle's electrical charging socket, do not use them. Please see an authorised dealer to replace them.

In the event of non-activation of the charging flap locking mechanism and/or unlocking of the vehicle's electric charging socket, please contact an approved dealer.

E-TECH PLUG-IN HYBRID VEHICLE (PHEV)

Charging cords

2

Charging lead A

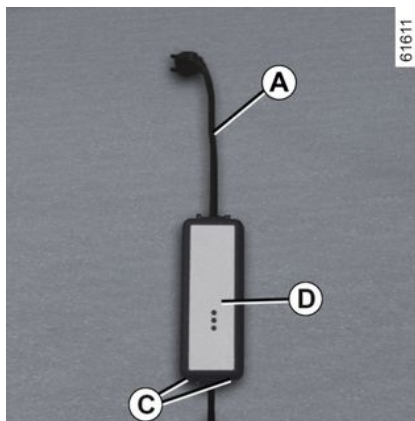

(14/16 amps)

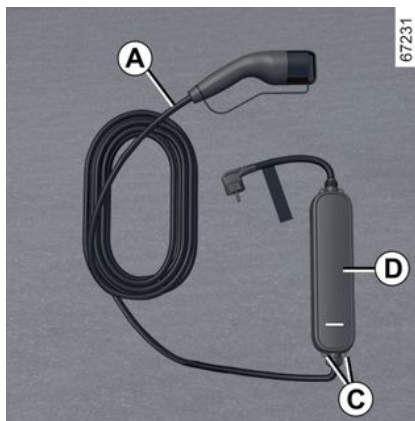

(10 amps)

Depending on the vehicle, either the 10 A or 16 A cable can be used for:

- in normal use, on a socket used only for the vehicle (14 A/16 A charging);
- occasional charging using a domestic socket (8 A charging) when you are not at home, for example.

In all cases, sockets must be fitted as stated in the instructions provided with the charging cable **A**.

In all cases, **carefully** read the charging cable user manual **A**.

 Never leave the socket hanging by the cord. Use the hooks **C** to hang it.

 If a malfunction occurs during the charging process (red warning light appears on the unit **D**), stop charging immediately. Please refer to cord instructions.

E-TECH PLUG-IN HYBRID VEHICLE (PHEV)

Charging cable *B*

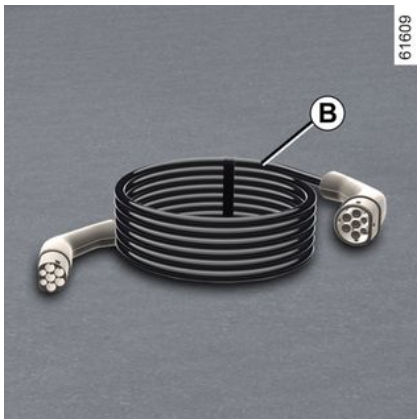

This lead is specific to your vehicle and designed for connecting to wall sockets or public terminals to enable standard charging of the traction battery.

i We recommend that you use a charging cord that enables a standard charge to charge the traction battery.

i Before cleaning the charging cable, make sure it is disconnected.

Clean the cable using a cloth slightly dampened with water. When cleaning, make sure that the cloth does not come into contact with the ends of the cable (connectors, charging pins) to avoid any risk of corrosion.

i Each charging lead is stored in the luggage compartment of the vehicle

→ 328.

E-TECH PLUG-IN HYBRID VEHICLE (PHEV)

Important recommendations

2



Important recommendations for charging your vehicle

Please read these instructions carefully. Failure to follow these instructions may lead to **a risk of fire, serious injury or electric shocks which could result in death.**

Choice of charging cord

The standard charging cords supplied with the vehicle have been designed specifically for this vehicle. It is designed to protect you against the risks of electric shock that can lead to death or fire.

Do not use with the charging leads of previous vehicles as they are not adapted.

For safety reasons, the use of a charging cord not recommended by the manufacturer is strictly forbidden. Failure to follow this instruction can lead to risks of fire or electric shock that can prove fatal. For information on a charging cord suited to your vehicle, please consult an authorised dealer.

Using the charging cable A

Please read the instructions that come with the charging lead carefully to learn about the precautions you must take when using the product and the technical specifications required for fitting the socket.

Installation

Wall socket

Have a special wall socket installed by a qualified professional.

In the case of domestic charging

Have a qualified professional check that each socket to which you will connect the charging cable complies with the standards and regulations in force in your country and that it complies with the specifications described in the information on "Power supply systems".

Power supply systems

Only use charging terminals which conform to the IEC 61851-1 standard and connecting points protected by:

- a Type A 30 mA residual current device specific to the socket used;
- an overcurrent protection device;
- protection against overvoltage relating to lightning in exposed areas (IEC 62305-4);
- an earth connection that complies with the standards in the relevant country.

E-TECH PLUG-IN HYBRID VEHICLE (PHEV)

Charging types that conform to European standards

Alternating current (AC)

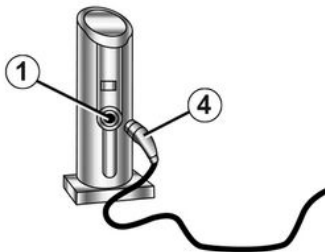

62364

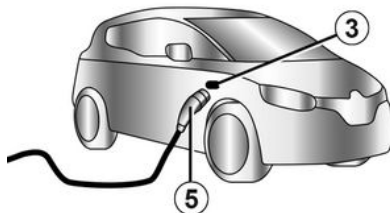
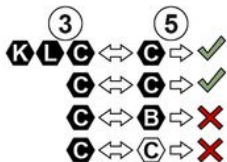

If the information is displayed on the vehicle charging flap, follow the instructions below.





Before plugging in a charging lead, check that:

- the colour and one of the letters of the input socket **1** correspond to the colour and one of the letters on the end **4** of the lead;
- the colour and one of the letters of the input socket **3** correspond to the colour and one of the letters on the end **5** of the lead.

E-TECH PLUG-IN HYBRID VEHICLE (PHEV)

Labels

2

Charging type	Alternating current (AC)			
Connection	Charging terminal 1 /Charging lead 4		Vehicle 3 /Charging lead 5	
Charging types that conform to European standards (for all other cases, please consult an approved dealer).				

E-TECH PLUG-IN HYBRID VEHICLE (PHEV)

Electric charging socket 3

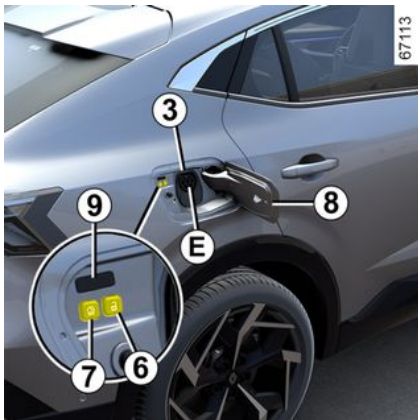



Note: if in a snowy environment, remove snow from the vehicle charging area on the passenger side before plugging in or disconnecting.

Snow in the socket may block the insertion of the charging cord plug.

The vehicle is fitted with a charging socket **E** located at the rear right-hand side of the vehicle for charging up to 7 kW.

There are also two buttons located inside the charging flap:

– the  button **6** unlocks the charging cable;

– The  button **7** launches immediate charging of the vehicle;

Precautions

Avoid charging and parking your vehicle in extreme temperatures (hot or cold).

Under extreme conditions, charging may take several minutes before starting (time required for the traction battery to cool down or warm up).

When the vehicle is parked for more than seven days in temperatures below approximately -25°C, charging the traction battery can become impossible.

When the vehicle is parked for more than three months with near zero charge, charging the battery can become impossible.

The energy level available depends on the battery temperature. It may therefore vary between stopping and restarting the vehicle if the battery is cold or warm.

To preserve the service life of your traction battery, avoid parking the vehicle for more than one month with high charge, especially when the weather is very hot.

Favour charging the traction battery after driving and/or in mild temperatures. Otherwise, charging may take a longer

period of time or even become impossible.

It is preferable to recharge the vehicle after driving if the charge level is low (< 25%) and in negative temperatures.

Advice

– In high temperatures, try to park and recharge the vehicle in a shaded/sheltered location;
– charging can be performed in the rain or snow.

Recharging the traction battery

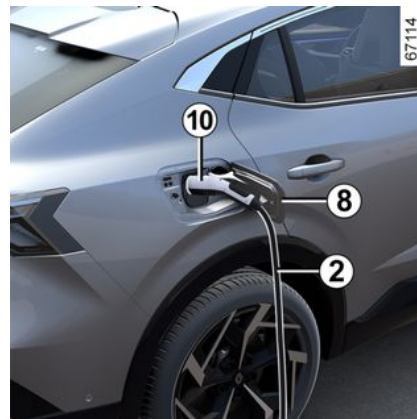

Vehicle stationary, ignition off:

– take the charging cable **2** located in the storage tray in your vehicle's luggage compartment;

E-TECH PLUG-IN HYBRID VEHICLE (PHEV)

– press the charging flap **8** to unlock it. The warning light **9** illuminates in white;

i Depending on the vehicle, when the charging flap is open or not properly closed, the "Charging flap open" message appears on the instrument panel.

– plug in the end of the lead to the power supply;
– grab the handle **10**;
– plug in the vehicle cord. The warning light **9** flashes in yellow;

i Do not use the charging flap **8** to hang the charging lead **2** while recharging the vehicle.

– after you hear a locking click, check that the charging cord is properly plugged in. To check the locking, pull gently on the handle **10**;
– if you have programmed a deferred charge and you wish to start charging immediately, press the button **7** to start charging ➔ **48**.

The charging cord is automatically locked with the vehicle. This will make it impossible to unplug the cord from your vehicle.

i If you have just accepted a system update via the multimedia system, the traction battery charging will be delayed or cancelled. Wait for the update to be completed before connecting the charging lead to the vehicle. For more information on system updates, please refer to the multimedia instructions.

i Make sure you fully uncoil the charging cord to limit its heating.

 Do not use an extension lead, multiple socket or adapter.
Fire hazard.

67293

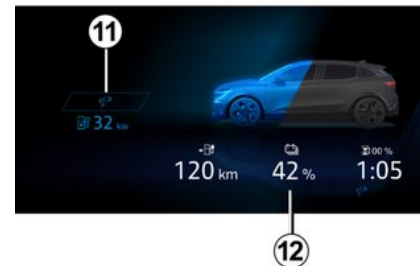

During charging, the warning light **9** flashes in blue.

When charging starts, the following information **12** appears on the instrument panel:

- the power level on the battery indicator light;
- the battery refill rate;
- an estimate of the remaining charging time (this is not displayed after the battery is charged to approximately 95%);
- the warning light **11** indicates that the vehicle is connected to a power supply;
- your vehicle range will vary according to the charge level.

E-TECH PLUG-IN HYBRID VEHICLE (PHEV)

The display on the instrument panel disappears after a few seconds. It reappears on the instrument panel when a door is opened.

i The traction battery charging time depends on the amount of energy remaining and the power delivered by the charging terminal. The information is displayed on the instrument panel during charging → 127.

Note: under certain conditions, the actual charging time may be longer than the charging time displayed on the instrument panel. This depends on:

- the quality of the electrical network;
- the initial charge level;
- the exterior temperature is too cold;
- ...

In the event of a problem with the charging cable, we recommend that you replace it with a cable that is identical to the original. Consult an approved dealer.

One charging is complete, the warning light **9** illuminates continuously in green.

You do not need to wait until the charge is at reserve levels to recharge your vehicle.

Operating faults

If the warning light **9** is illuminated continuously in red, please contact an approved dealer.

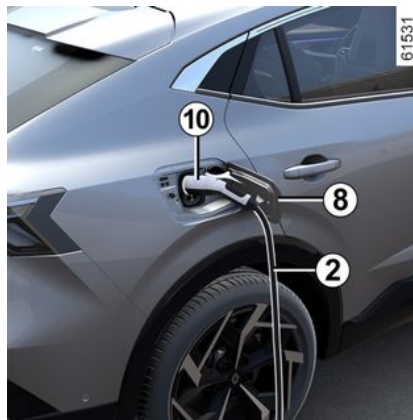

Precautions to take when removing from the socket

i It is imperative to follow the unplugging steps in order.

- Press the button **6** or **press and hold** the door unlocking button on the card in order to release the vehicle charging lead;
- grab the handle **10**;
- unplug the charging lead **2** from the vehicle;
- you must close the charging flap **8** and press on it to lock it;
- disconnect the lead **2** from the power supply **1**;
- store the lead **2** in the storage compartment of your luggage compartment.

Note: immediately after a long period of charging the traction battery, the lead may be hot. Please use the handles.

i After pressing the charging cable release button, you will have around 30 seconds to unplug it before it is locked once again.

E-TECH PLUG-IN HYBRID VEHICLE (PHEV)

Label 13

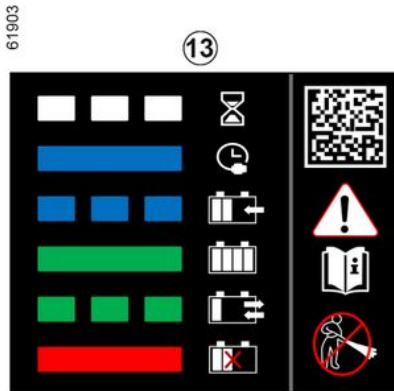

The label **13** located on the charging flap **8** provides information on the charging operation according to the status of the warning light **9**:

- when it flashes in white this indicates that the lead is plugged into the vehicle and the system is carrying out its checks;
- when it lights up continuously in blue this indicates that charging programming is activated;
- when it flashes in blue this indicates that charging is in progress;
- when it lights up continuously in green this indicates that the vehicle is fully charged;

– when it lights up continuously in red this indicates an operating fault.

The label **13** located on the right-hand side reminds you of the following instructions:

- do not wash the charging flap using a high-pressure water jet;
- with the vehicle stationary, the valve and the charging flap can be opened;
- when the vehicle is being driven, the valve and the charging flap must be closed;
- open the flap to connect the charging lead;
- close the flap again once disconnected;
- connect to a domestic socket, an alternating current charging terminal or a quick charging terminal;
- for any information on charging, please consult your vehicle user manual.

Charging programming

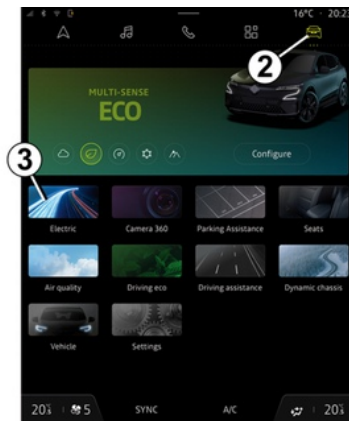
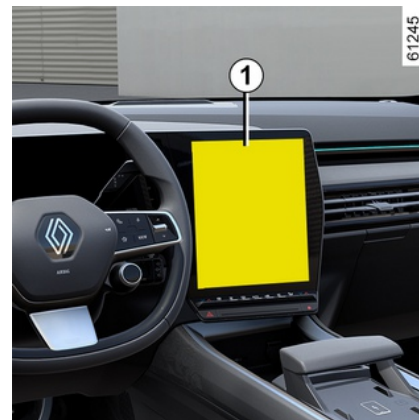

E-TECH PLUG-IN HYBRID VEHICLE (PHEV)

With the vehicle stationary and the engine on, from the "Vehicle" world **2** on the multimedia screen **1**, press the "Electric" menu **3** then the "Charging & Air conditioning" tab to programme your vehicle charging.

You can choose from several charging modes:

- "Immediate charging";
- "Programme".

Please refer to the multimedia instructions for further information.



For safety reasons, carry out these operations when the vehicle is stationary.

When the programming is confirmed,

the indicator light  lights up on the instrument panel.

Note: charging will start if the engine is switched off, the vehicle is connected to a power supply and access is authorised.



If you have just accepted a system update via the multimedia system, the traction battery charging will be delayed or cancelled.

Wait for the update to be completed before connecting the charging lead to the vehicle.

For more information on system updates, please refer to the multimedia instructions.

CARD

General information

2

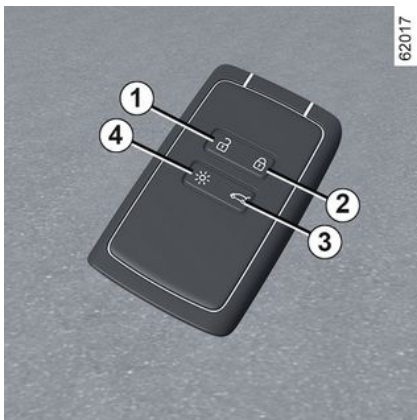

1. Unlocking the doors and luggage compartment.
2. Locks all the opening elements.
3. Locking/unlocking the luggage compartment and, depending on the vehicle, automatic opening/closing of the tailgate.
4. Switching on the lighting remotely.

The card is used for:

- locking/unlocking the opening elements (doors, luggage compartment and fuel filler flap);
- switching on the vehicle lighting remotely;

– automatic remote opening/closing of the electric windows → 317.

 Depending on the vehicle, you may have a digital key that offers all the functions of the card. However, if a card has been left inside the vehicle and the doors have been locked with a digital key, all of the card's functions will be inhibited. For further information, please see the "Digital key" section → 58.

Range

Make sure that the correct battery type is being used, and that the battery is in good condition and inserted correctly. Its service life is approximately two years: replace it when the "Card battery low" message appears on the instrument panel → 56.

card operating range

This varies according to the surroundings: take care not to accidentally lock or unlock the vehicle by inadvertently pressing the buttons on the card.

Note: if a door or the luggage compartment door is open or not properly shut, the vehicle will not be locked. A

beep sounds and the hazard warning lights and side repeaters do not flash.

 If the battery is flat, you can still lock/unlock and start your vehicle → 62 → 160.

"Remote lighting" function



Press button 4 to switch on the dipped beam headlights and the exterior lighting for approximately 20 seconds. This can be used, for example, to identify the vehicle from a distance when parked in a car park.

CARD

Press and hold button **4** for approximately two seconds to switch on the exterior lighting and emit a sound.

Note: press button **4** again to switch off the lighting.



Recommendations

Avoid leaving the card in hot, cold or humid areas.

Do not keep the card in a place where it could be bent or damaged accidentally, such as in your back pocket.



Replacement: need for an additional card

If you lose your card or require another, you can obtain one from an approved dealer. If a card is replaced, it will be necessary to take the vehicle **and all its cards** to an approved Dealer to initialise the system. You may use up to four cards per vehicle.

Interference

Interference by factors in the immediate vicinity (external installations or the

use of equipment operating on the same frequency as the card) may disrupt its operation.



Driver's responsibility when parking or stopping the vehicle

Never leave an animal, child or adult who is not self-sufficient alone in your vehicle, even for a short time.

They may pose a risk to themselves or to others by starting the engine, activating equipment such as the electric windows or locking the doors.

Also, in hot and/or sunny weather, please remember that the temperature inside the passenger compartment increases very quickly.

RISK OF DEATH OR SERIOUS INJURY.

Fitting a hand strap 7

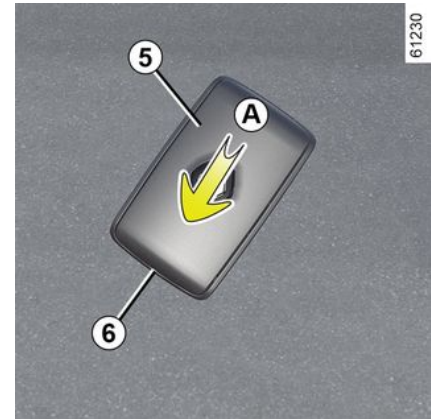

Slide the rear casing **5** downwards while pressing on area **A**.

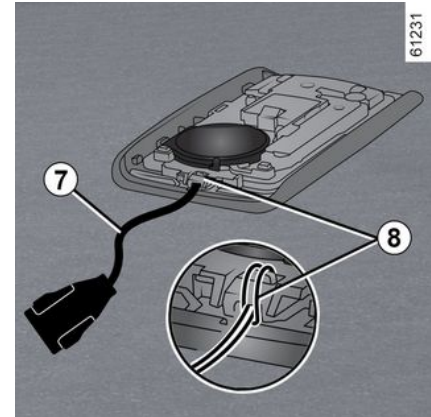

CARD

Insert the hand strap into the component **8** and pass the end of the strap through the buckle.

Position the strap at the opening **6** and close the casing.

Note: check that the diameter of the hand strap cord **7** fits the opening **6**.

Use

There are three ways to unlock/lock the vehicle:

- in "hands-free" mode, when approaching and moving away from the vehicle;
- using the card in remote control mode;
- by using the digital key as a remote control (depending on the vehicle). For further information, please see the "Digital key" section → **58**.



Do not store the card anywhere it may come into contact with other electronic equipment (computer, phone etc.) as this could hinder its operation.

Deactivating/activating the "hands-free mode"

Depending on the vehicle, you can deactivate/activate unlocking when approaching and locking when moving away from the vehicle.

You can also deactivate/activate the sound signal that is emitted upon locking when moving away from the vehicle → **130**.



Never leave your vehicle with the card inside.



Driver's responsibility when parking or stopping the vehicle

Never leave an animal, child or adult who is not self-sufficient alone in your vehicle, even for a short time.

They may pose a risk to themselves or to others by starting the engine, activating equipment such as the electric windows or locking the doors.

Also, in hot and/or sunny weather, please remember that the temperature inside the passenger compartment increases very quickly.

RISK OF DEATH OR SERIOUS INJURY.

CARD

"Hands-free" unlocking when approaching the vehicle



61232

If the card is in the access zone **1** the vehicle will be unlocked. Unlocking is indicated by **one flash** of the hazard warning lights and the indicator lights.



Depending on the vehicle, the door mirrors fold in/out automatically when the vehicle is locked/unlocked → 141.

"Hands-free" locking when moving away from the vehicle



61233

With the card on you and the doors and luggage compartment door closed, move away from the vehicle: it will be locked automatically as soon as you leave the access zone **1**.

Note: the distance at which the vehicle locks depends on the surroundings. To confirm that the vehicle has been locked, **the hazard warning lights flash twice and then light up** for approximately four seconds accompanied by a beep.

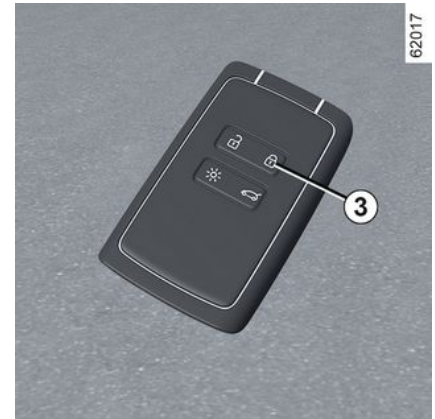

62017

2

If the card has been within the detection zone **1** for approximately 15 minutes, remote locking is deactivated. To lock the vehicle, press the button **3** on the card.

The vehicle cannot be remotely locked if the card is within the zone **2**.

CARD

"Hands-free" unlocking by opening the luggage compartment

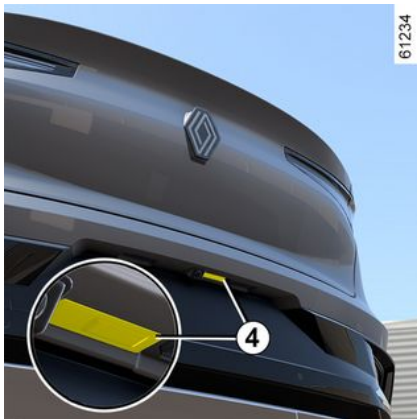

With the card in the zone **1** and the vehicle locked, press button **4** once to unlock the entire vehicle.

The hazard warning lights **flash twice** to indicate that the vehicle is unlocked and, depending on the vehicle, the door mirrors automatically fold out.

Special features of the unlocking system

Under certain circumstances, approach unlocking is deactivated:

- if the vehicle has not been used for eight days;

- if the card remains close to vehicle zone **2** during approximately five minutes **after the vehicle has been unlocked**;
- after several passes in the vicinity of zone **2** **without the doors having been opened**.

Press the luggage compartment door opening button **4** or use the card as a remote control to unlock the vehicle and reactivate "hands-free" mode.

Special features relating to locking in "hands-free" mode

After locking in "hands-free" mode, you have to wait approximately three seconds before being able to unlock the vehicle again. During these three seconds, the door handles can be tried to make sure that the vehicle is locked properly.

Note: if a door or the luggage compartment door is open or not properly shut, the vehicle will not be locked. A beep sounds and the hazard warning lights and side repeaters do not flash.

Using the card as a remote control

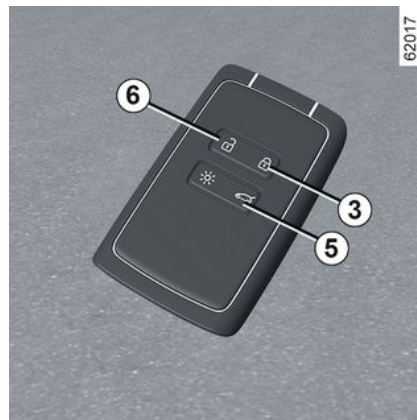

Unlocking with the card

Press the button **6**. The hazard lights and side repeaters **flash once** to confirm that the doors have been unlocked and, on some vehicles, the door mirrors fold out automatically.

Press and hold the button **6** to unlock the vehicle and open the front and rear windows (depending on the vehicle). In the case of a vehicle equipped with a motorised tailgate, press the button once **5** to unlock the vehicle and open the tailgate.

Pressing the button **5** again closes the motorised tailgate but does not lock the vehicle. To lock the vehicle, press the button **3**.

CARD

Locking using the card

With the doors and luggage compartment door closed, press button **3**: the vehicle will be locked.

The hazard warning lights **flash twice** to indicate that the vehicle is locked and, depending on the vehicle, the door mirrors automatically fold in.

Depending on the vehicle, press and hold button **3** to lock the vehicle and close the front and rear windows.

Note:

- the maximum distance at which the vehicle locks depends on the surroundings;
- if a door or the boot is open or not properly shut, locking is not carried out. A beep sounds and the hazard warning lights and side repeaters do not flash.



The card buttons are deactivated when the engine is running.



61233

After a door is opened and closed **while the engine is running**, if the card is no longer in zone **2**, the "Card not detected" message warns you that the card is no longer in the vehicle. This will, for example, prevent you from driving away after dropping off a passenger who has kept the card on them.

The warning disappears when the card is detected again.

Locking/unlocking the boot only

In the case of a vehicle equipped with a manual (non-motorised) tailgate, press the button **5** to lock/unlock the luggage compartment only.

Deadlocking

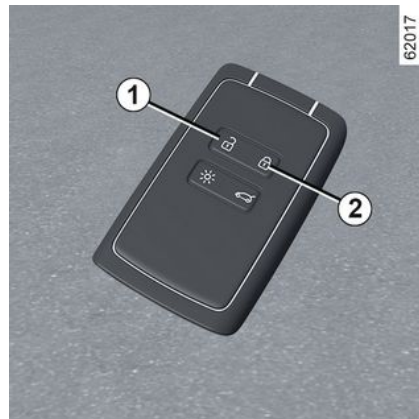

62017

If the vehicle is equipped with a deadlocking function, this allows you to lock the opening elements and to prevent the doors from being unlocked using the interior handles (for example, by breaking the window and then trying to open the door from the inside).



Never use deadlocking if someone is still inside the vehicle.

To activate deadlocking

Press button **2** twice in quick succession.

CARD

The hazard warning lights and side indicator lights give **two slow flashes and three quick flashes to confirm locking**.

Depending on the vehicle, the door mirrors may fold in automatically when the vehicle is locked → 141.

To deactivate deadlocking

Press button **1** once.

The hazard warning lights **flash once** to indicate that the doors have been unlocked.



Depending on the vehicle, you may have a digital key that offers all the functions of the card. However, if a card has been left inside the vehicle and the doors have been locked with a digital key, all of the card's functions will be inhibited. For further information, please see the "Digital key" section → 58.

Battery

Replacing the battery

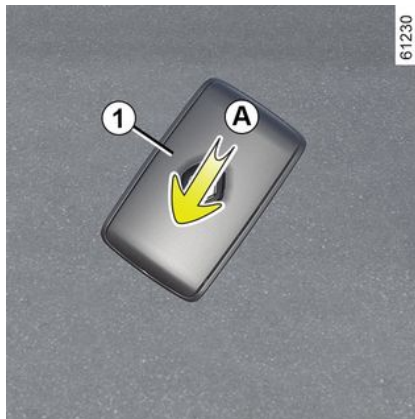

When the "Card battery low" message appears on the instrument panel, replace the battery in the card:

- slide the rear casing **1** downwards while pressing on area **A**;
- remove the battery cover **2**;
- remove the battery by pressing on one side and lifting the other;
- replace it according to the direction and template shown inside the cover.

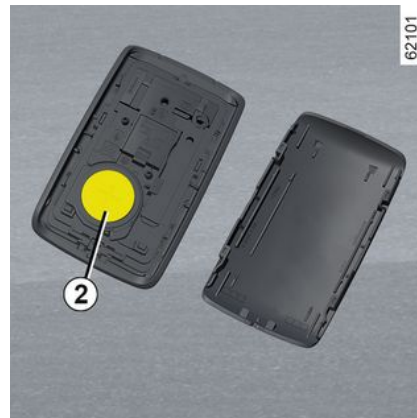

To refit, proceed in the reverse order then press one of the buttons on the card four times while you are near the vehicle: the next time the vehicle is started, the message will disappear.

Check that the cover is clipped shut.

Note: when replacing the battery, do not touch the electronic circuit or contacts on the card.



The batteries are available from approved Dealers, and their service life approximately two years. Check that there is no dye on the battery: risk of an incorrect electrical contact.

CARD



If they need to be replaced, be sure to use the same or equivalent type of battery (consult an Approved Dealer).



When replacing:
– make sure that the batteries are correctly inserted.

Risk of explosion.

– if the flap does not close correctly, do not use and keep out of reach of children.

Operating faults

If the battery is too weak to ensure correct operation, you will still be able to start and lock/unlock the vehicle ➔ **62**.



61496



Do not throw away your used batteries; give them to an organisation responsible for collecting and recycling batteries.



Precautions relating to batteries:

- keep batteries (new or used) out of reach of children;
- do not swallow batteries;

Risk of chemical burns which may lead to death.

- if ingested or inserted into any part of the body, consult a doctor as soon as possible.

2

DIGITAL KEY

Depending on the country and subscription, you can install a digital key for your vehicle on your smartphone.

The digital key contains the rights required to lock/unlock and start your vehicle using a smartphone. Thus, your smartphone replaces your card.

General information

The installation, administration and transmission of the digital keys are carried out using the manufacturer's app.

Once the manufacturer's application is installed on your smartphone and the subscription is activated, the digital key must be activated from the manufacturer's application.

 If you need to entrust your vehicle to somebody else, make sure you have the vehicle card with you to guarantee access to the vehicle (e.g. in the context of an intervention on the vehicle, an appointment with an approved dealer or a qualified professional, etc.).

Secure access to the digital key on the smartphone

It is the responsibility of the owner of the digital key and the designated users to protect and secure access to the digital key on the smartphone.

Make sure that you install the necessary security and protection tools on your smartphone (such as securing the screen with a password).

Operating conditions

Activate Bluetooth® on your smartphone then open the manufacturer's application to access the various digital key functions.

Note: the smartphone must be sufficiently charged in order to use a digital key. In the event of a low charge level, the "Low smartphone battery" message appears on the instrument panel.

 The digital key's operational reach will depend on your smartphone's Bluetooth® connection.

Lending a digital key

From the manufacturer's app, access the "Share Virtual Key " menu and fill in the information for the occasional user. After validation, a confirmation email will be sent to the user.

 In the event of a loan, the owner of the digital key is responsible for designating a trusted person as a vehicle user.

To avoid any error in the transmission of a digital key to an occasional user (for example: lack of Wi-Fi or mobile network, etc.), be sure to anticipate the loan procedure.

To do this, make sure that:

- the manufacturer's application has previously been downloaded and installed by the occasional user.
- your smartphone and the occasional user's smartphone are connected to

DIGITAL KEY

the internet throughout the procedure (via Wi-Fi or mobile networks);
– the occasional user's digital key is activated once the procedure is completed.

Revoking a digital key

The user can individually revoke a digital key. Once a digital key has been revoked, the user can activate a new key.

For more information, please see the manufacturer's application.

Activation/deactivation from the multimedia screen

It is possible to deactivate and reactivate the "Digital key" function so that the vehicle does not communicate with any digital key. Please refer to the multimedia instructions.

Note: deactivating the function will not delete existing digital keys. It only deactivates the vehicle's capacity to communicate with them.

Locking/unlocking the doors and luggage compartment, deadlocking, remote lighting

The first time the vehicle is unlocked or started using a new digital key or a new smartphone, it will take several

seconds for the vehicle to identify the digital key installed on your smartphone.

From your smartphone, with Bluetooth® activated, open the manufacturer's application and discover the various functions available for your digital key. They are identical to those of your card.

Special features related to unlocking the opening elements

Under certain circumstances (e.g. after eight days of the vehicle not being used), it is not possible to unlock the vehicle using a digital key: press the luggage compartment opening button then unlock your vehicle using your digital key.

These functions are:

- locking/unlocking all the opening elements → 52;
- locking/unlocking the luggage compartment (depending on the vehicle) → 52;
- deadlocking (depending on the vehicle) → 55;
- activating the lighting remotely → 50;
- remote sounding of the horn (allows you to identify the vehicle from afar or when parked in a crowded car park, for example);
- starting/stopping the engine → 160.

Starting, stopping the engine



Upon first use and each time a new smartphone is used, it is necessary to calibrate your digital key with your vehicle.

To do this, activate Bluetooth® on your smartphone then follow the procedure from the manufacturer's application.

When calibrating, the smartphone must be placed in the placement area **1**.

To start/stop the engine, the system checks that the smartphone is present in the placement area **1** before allowing the engine to be started.

DIGITAL KEY

For more information, please refer to the information on "Starting, stopping the engine" → 160.

The smartphone must remain in the vehicle throughout the journey.

Note:

If a digital key is being lent, you can delete it by carrying out the revoking procedure using the smartphone while it is placed in the placement area **1**.

Otherwise, the deletion request is left pending and is only confirmed once the engine is started using another digital key or a card.



It is necessary to place the smartphone in the placement area in order to start and stop the engine and when calibrating.



If the smartphone is no longer in the passenger compartment when you try to switch the engine off, a message is displayed on the instrument panel: press and hold the engine start/stop button **2** for more than two seconds.

If the smartphone is no longer in the passenger compartment, make sure you can retrieve it before pressing and holding. Without a smartphone or card, you will not be able to start the vehicle again.

Special features of the digital key

– For the digital key to remain active, the smartphone concerned must be connected to the Internet (via WIFI or

mobile network) at least once every 48 hours. Otherwise, connect your smartphone to the internet for a few minutes so that the digital key can be reactivated.

– If a card has been left inside the vehicle and the doors have been locked with the digital key, all of the card's functions will be inhibited. The card's functions will remain inactive until the engine is started again.

In this case, to start the engine you will need to use either the digital key or a card other than that left inside the vehicle.



When the engine is started or stopped, the smartphone should always be sufficiently charged in order to use the digital key.

DOORS AND OPENING ELEMENTS

Opening and closing the doors

Opening from the outside



Front doors

With the doors unlocked or the card on you, hold the handle **1** and pull it towards you.



Rear doors

With the doors unlocked or the card on you, hold the handle **2** and pull it towards you.

Opening from the inside

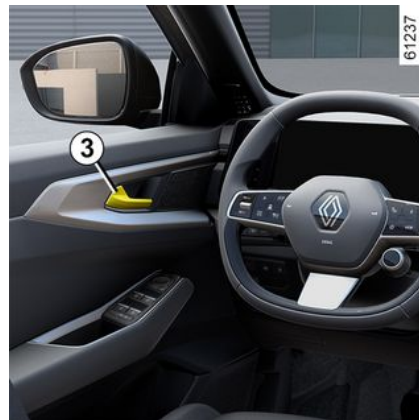

Pull the handle **3**.

Depending on the vehicle, it may be necessary to pull the handle **3** twice: the first time to unlock the door, the second time to open it.



As a safety precaution, the doors should only be opened/closed when the vehicle is stationary.

Lights-on reminder buzzer

If you have switched off the ignition and left the lights switched on, a warn-

DOORS AND OPENING ELEMENTS

ing buzzer will sound when a door is opened.

2

Door or luggage compartment lid open buzzer

With the vehicle stationary and the ignition on, the  warning light appears on the instrument panel accompanied by a warning light indicating which of the opening elements (door(s), luggage compartment) are open or incorrectly closed.

Once the vehicle reaches a speed of approximately 6 mph (10 km/h), a warning light indicates if the door(s) or luggage compartment are open or not properly closed and the "Luggage compartment open" or "Door open" message and a beep will sound for around 40 seconds until the door or luggage compartment is closed.

Child safety



To prevent the rear doors being opened from the inside, move the lever **4** and check from the inside that the doors are securely locked.



Driver's responsibility when parking or stopping the vehicle

Never leave an animal, child or adult who is not self-sufficient alone in your vehicle, even for a short time.

They may pose a risk to themselves or to others by starting the engine, activating equipment such as the electric windows or by locking the doors.

Also, in hot and/or sunny weather, please remember that the temperature inside the passenger compartment increases very quickly.

RISK OF DEATH OR SERIOUS INJURY.

Locking, unlocking the opening elements

If the card does not work

In certain cases, the card may not work:

- when the card battery is flat or the vehicle battery is discharged, etc.;
- use of appliances operating on the same frequency as the card (mobile phone, etc.);

DOORS AND OPENING ELEMENTS

- the vehicle is located in a high electromagnetic radiation zone;
- vehicle locked using a digital key
➔ 58.

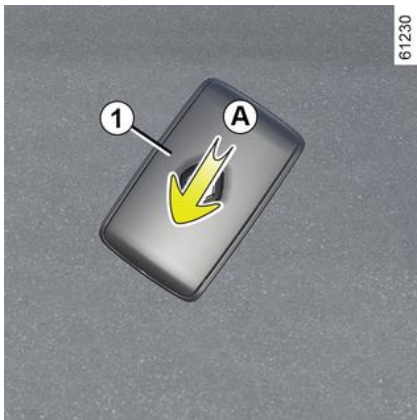

It is then possible:

- to use the radio frequency remote control or the emergency key integrated into the card (depending on the vehicle) to unlock the driver's door;
- to use the interior door locking/unlocking control;
- to use the digital key, depending on the vehicle ➔ 58.

The card's built-in key

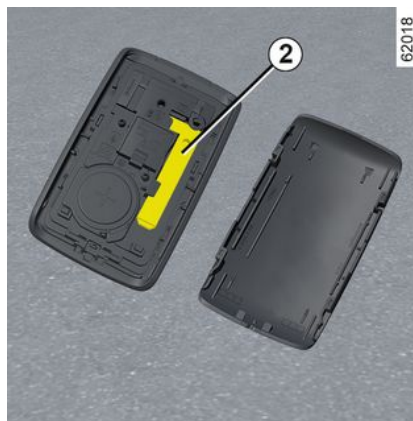

The built-in key **2** can be used to lock or unlock the driver's door when the card is not working.

Access with key 2

Slide the rear casing **1** downwards while pressing on area **A**.

Using the key integrated in the card

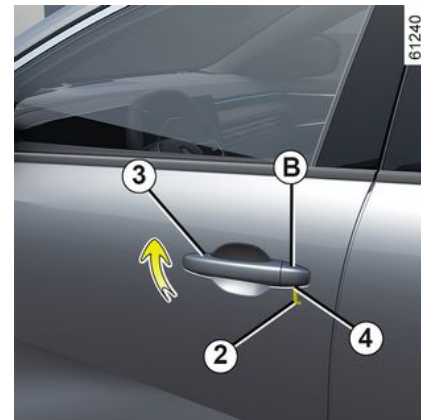

- Pull the handle **3**;
- press downwards on the cover **B** on the driver's door;
- insert the end of the key **2** into the notch **4** at the bottom of the cover **B**;
- rotate it upwards to remove the cover **B**;
- insert the key **2** into the lock of the driver's door, then lock or unlock.

Once you are inside the vehicle, put the key back in its casing in the card.

DOORS AND OPENING ELEMENTS

Locking the doors manually



With the door open, turn the screw **5** (using the end of the key) and close the door.

This means that the door is then locked from the outside.

The doors may then only be opened from the inside or by using the key in the driver's door.

Interior locking/unlocking door control

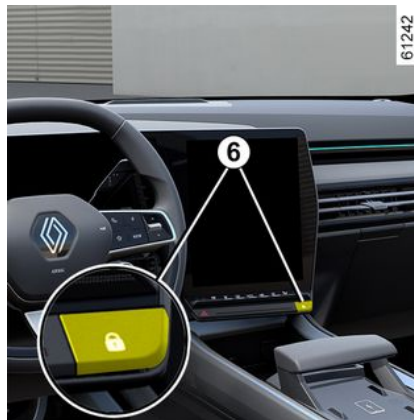

The switch **6** controls the doors, the luggage compartment door and the fuel filler flap simultaneously.

If a door or the tailgate is open or not closed properly, the doors and tailgate lock/unlock quickly.

If transporting an object with the luggage compartment open, you can still lock the other doors: with the engine stopped, press and hold switch **6** for more than five seconds to lock the doors.

Door and tailgate status indicator

With the ignition on, the switch **6** warning light indicates the locking status of the opening elements:

- when the warning light is on, the doors and luggage compartment door are locked;
- indicator light off, the doors and tailgate are unlocked.

When you lock the doors, the indicator light remains lit and then goes out.



Driver's responsibility

If you decide to keep the doors locked when you are driving, remember

that it may be more difficult for those assisting you to gain access to the passenger compartment in the event of an emergency.

Locking the opening elements without the card or the key

For example, in the event of a discharged battery or the card or key temporarily not working etc.

With the ignition off and a door or the luggage compartment open, press and hold switch **6.**

DOORS AND OPENING ELEMENTS

When the door is closed, all the doors and tailgate will be locked.

Note: it is only possible to unlock the vehicle from the outside while the card is in the vehicle's access zone, or by using the key.



Never leave your vehicle with the key or card inside.

Automatic locking when driving

Operating principle



After the vehicle is started, the system automatically locks the doors when

you reach approximately 6 mph (10 km/h).

The door can be unlocked:

- by pressing the door unlocking switch **1**;
- at a standstill, by opening a front door from inside the vehicle.

Note: if a door is opened/closed, it will automatically lock again when the vehicle reaches a speed of approximately 6 mph (10 km/h).

Activating/deactivating the function

To activate it: with the vehicle stationary and the engine running, press switch **1** for at least five seconds until you hear a beep.

To deactivate it: with the vehicle stationary and the engine running, press switch **1** for at least five seconds until you hear two beeps.

The function can also be activated and deactivated via the multimedia screen → **130** (depending on the vehicle).

Operating faults

If you experience an operating fault (no central locking, the switch light **1** does not light up when trying to lock the doors and luggage compartment, etc.), make sure that central locking has not been deactivated by mistake and check that all of the opening ele-

ments are properly closed. If they are properly closed, contact an approved dealer.



Driver's responsibility

If you decide to keep the doors locked when you are driving, remember that it may be more difficult for those assisting you to gain access to the passenger compartment in the event of an emergency.

DOORS AND OPENING ELEMENTS

Luggage compartment

To open

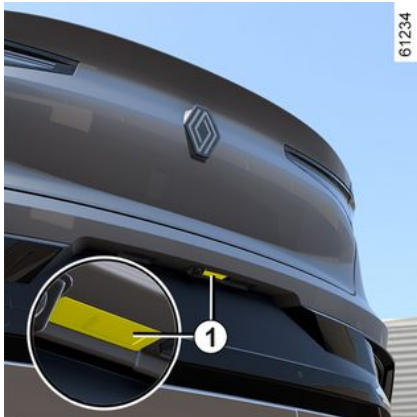

Press the button **1** and open the door.

To close

Lower the luggage compartment door using the interior handles **2**.



Never use the struts to close the luggage compartment door.

Opening manually from inside the vehicle

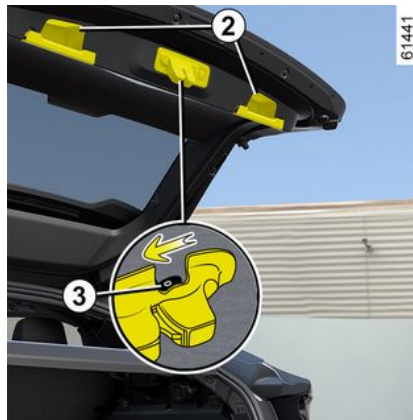

If it is impossible to unlock the luggage compartment, it can be done manually from inside:

- access the luggage compartment by folding down the rear bench seatback(s);
- insert a pencil or similar object into the recess **3** and slide the unit as shown in the illustration;
- push the boot lid to open it.



The attaching of any carrying device (bike rack, luggage box etc.) resting on the luggage compartment lid is prohibited. To install a carrying device on your vehicle, contact an approved dealer.

Automatic tailgate

Conditions of use

- Immobilise the vehicle.
- If there is any ice or snow preventing the tailgate from opening, this ice or snow must be removed to free the tailgate.
- In the event that the battery is discharged or if it is replaced, the tailgate should be closed (manually if necessary) to restart the tailgate motor.

Opening/Closing

The opening or closing of the motorised tailgate is indicated by **three sound signals**.

DOORS AND OPENING ELEMENTS



Ensure that nobody is close to the moving parts when opening/closing the tailgate.

Risk of injury.

Depending on the equipment, the tailgate locks and unlocks at the same time as the doors.

There are various ways to handle the tailgate:

- using the card as a remote control;
- using the controls on the bumper;
- using the dashboard control;
- depending on the vehicle, using the "hands-free" function.



To avoid damaging the tailgate system, do not manually force the tailgate to open or close while it is moving.

using the remote control card

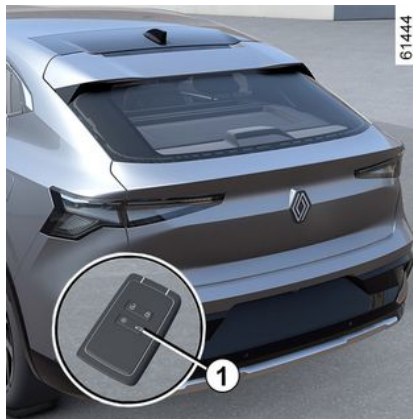

With the engine off, press and hold the switch **1** on the card while near the luggage compartment.

Using the exterior opening control

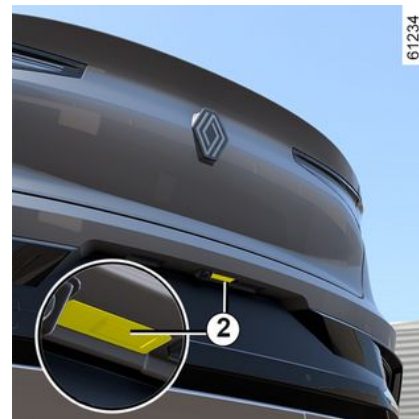

Press the control **2**.

2

DOORS AND OPENING ELEMENTS

Using the tailgate interior closing control



Press the control **3**.

Using the dashboard control



To open the tailgate, press and hold the switch **4** until you hear the sound signal, then release the switch.

To close the tailgate, press and hold the switch **4** until the tailgate closes completely. A beep sounds throughout the operation.

Note: if you let go of the switch **4** before the tailgate is completely closed, the closing operation is interrupted.

Using the "hands-free" function

(depending on the vehicle)

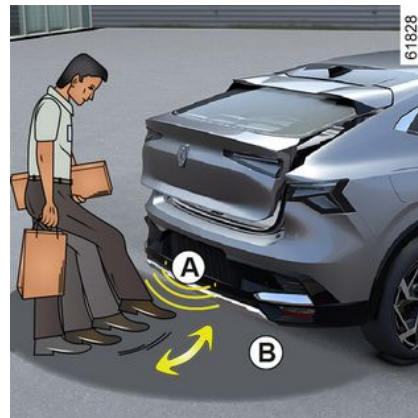

The "hands-free" function allows you to access the luggage compartment when you have your hands full. Ensure that the card is located in the rear area of the vehicle (area **B**). Stand approximately 45 centimetres from the vehicle's rear bumper and move your foot forwards/backwards in area **A**.

The sensor detects the approach and removal of your foot and triggers the opening or closing of the tailgate.

Do not keep your foot in the air. Perform the movement without stopping and without touching the rear bumper.

Note: with the tailgate open, after detecting a closure control, it waits around three seconds before triggering

DOORS AND OPENING ELEMENTS

the closure (a beep is emitted every second).

Activation/deactivation of the "hands-free" function

(depending on the multimedia system)

From the multimedia screen, access the "Vehicle" world, select the "Vehicle" tab then the "Access" menu. Activate or deactivate "Hands-free locking/unlocking".

Special feature of the "hands-free" function

- The "hands-free" function is no longer available after the vehicle has not been used for a few days, or after around 10 minutes if the vehicle is unlocked. To reactivate it, use the unlocking button on the card.
- The "hands-free" function is only available if the vehicle is stationary and the engine is switched off (and not put on standby using the "Stop and start" function).
- The "hands-free" function may not work if the vehicle is equipped with a towbar or if located in an area with a high electromagnetic radiation.



Deactivate the "hands-free" function before you:

- wash the vehicle in a roller-type car wash;
- wash the vehicle by hand;
- handle the emergency spare wheel or the towing equipment;
- ...

Risk of accidental opening of the tailgate which may cause injury.

Stopping the tailgate manoeuvre

The automatic tailgate manoeuvre can be stopped at any time by a short press on one of the controls.

If the tailgate is stationary in the intermediate position, your next press will move the tailgate in the opposite direction to when you stopped it.

Manual mode

After stopping the tailgate, you can perform the manoeuvre manually if you wish.

You can switch to the automatic manoeuvre at any time by pressing one of the controls.

Obstacle detection

If the tailgate detects an obstacle during its manoeuvre then it will stop. It will then be released from the obstacle following a small movement in the opposite direction, before stopping completely.

Press a tailgate opening/closing control to resume the tailgate operation.



DOORS AND OPENING ELEMENTS

2



The obstacle detection is an aid to opening and closing the tailgate, it does not in any way replace the user's care or responsibility.

Ensure that nobody is close to the moving parts when opening/closing the tailgate.

When opening/closing the tailgate, small objects may not be detected.

Ensure that no body parts (arms, hands, fingers etc.) are near the moving tailgate parts.

The detection is inactive at the end of the movement, before the tailgate is fully closed.

If the tailgate jams, stop the operation by pressing briefly on one of the controls.

Risk of serious injury.

Limiting the tailgate opening angle



You can adjust the maximum tailgate opening height. It will always stop at the chosen position:

- open the tailgate to an intermediate position;
- manually adjust the tailgate to the chosen position;
- press the motorised tailgate control **3** for more than three seconds to save the position.

Two beeps will sound to notify you that the position has been saved.

User precautions

- Before opening/closing the tailgate, ensure that the surrounding space is

sufficient to allow the tailgate to operate.

- Avoid multiple manual stops during the automatic tailgate movement (risk of damaging the tailgate system).
- The "hands-free" system may be temporarily disrupted if the rear bumper is dirty (dirt, mud, snow, gritting salt, etc.). Clean the rear bumper. If there is still a problem, contact an approved dealer.

Operating faults

If you activate the automatic tailgate continuously for around a minute (sequence of opening and closing), it will stop in order to avoid overheating. The operation will return to normal after about a minute.

The automatic tailgate will not operate if the battery is on low charge. In this case, operate the automatic tailgate with the engine started.

Note: in very cold weather conditions, the automatic opening may not work if the tailgate seals are frozen.

DOORS AND OPENING ELEMENTS



Driver's responsibility when parking or stop- ping the vehicle

Never leave your vehicle with a child, an adult who is not self-sufficient or a pet inside or at the rear of the tailgate, even for a short while.

They may pose a risk to themselves or to others by starting the engine, activating equipment such as the electric windows, the automatic tailgate or by locking the doors.

**RISK OF DEATH OR SERIOUS
INJURY.**



The attaching of any carrying device (bike rack, luggage box, etc.) resting on the luggage compartment lid is prohibited. To install a carrying device on your vehicle, contact an Approved Dealer.

FACIAL RECOGNITION

2



After saving your profile from the multimedia system, it is possible to recall the driver's user settings (driving position, etc.) using the camera **A** when entering the vehicle.

For more information on storing a profile using facial recognition, please refer to the multimedia user manual.

The system is activated when the driver's door is closed. As soon as it detects a registered profile related to the facial recognition, a profile unlocking code is displayed on the multimedia system.

Enter your code to activate the pre-stored settings (driving position, phone connection, calendar, etc.).

If the face image is not recognised by the camera during recognition, the system suggests the last profile used.

Note: make sure that the camera is not obscured (by dirt, mud, etc.).



When recalling a position (memorisation, changing profile), make sure that no one is near the moving parts (in particular, in the rear seats).
For safety reasons, carry out any adjustments when the vehicle is stationary.

FRONT SEATS

Front headrests

To raise the headrest



61286

Pull the headrest upwards to the desired height. Check that it is correctly locked.

To lower the headrest

Press the button **1** and guide the headrest down to the desired height. Check that it is correctly locked.

To move the headrest forwards or backwards

Depending on the vehicle, pull the headrest forwards to move it forward.

To move it backwards, press the button **1** and push it backwards.

Note: it is not possible to remove the front headrests.

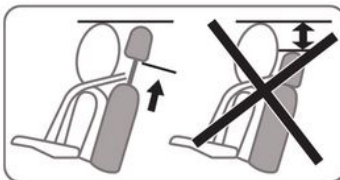

61287



The headrest is an important safety component: ensure that it is in place and in the correct position. The top of your head should be in line with the top of the headrest. The distance between your head and section **A** should be as short as possible.

Front seats with manual control

To move the seat forwards or back



63560

2

Raise the handle **1** to unlock. Release the handle at the desired position and make sure that it is locked.



After making adjustments, make sure that the seatbacks are correctly locked in place.

To raise or lower the seat base

(depending on the vehicle)

FRONT SEATS

Move lever **2** as many times as necessary upwards or downwards.

2

To tilt the seatback

Lift handle **3** and tilt the seatback to the desired position. Release the handle at the desired position and make sure that it is locked.



For safety reasons, carry out any adjustments while the vehicle is stationary.

We would advise you not to recline the seatbacks too far to ensure that the effectiveness of the seat belts is not reduced.

Nothing should be placed on the floor (area in front of the driver) as these objects may slide under the pedals during sudden braking manoeuvres, thus obstructing their use.

Heated seats

(depending on the vehicle)

With the ignition on, you can activate the heated seats via the multimedia screen:

– an initial press on the pictogram



of the desired seat activates the heating system at maximum power.

Three switch-integrated warning lights are illuminated;

– a second press decreases the heating to medium power. Two integrated warning lights are illuminated;

– a third press decreases the heating to minimum power. One integrated warning light is illuminated;

– a fourth press turns the heating off.

In order to avoid unnecessary energy consumption, the heated passenger seat can be deactivated automatically in the absence of an occupant.

Operating faults

When an operating fault is detected, the warning lights on the pictogram for the seat concerned will flash.

Consult an approved dealer.

Front seats with electric controls



On equipped vehicles, the switch **1** can be used to access the "Seats" menu on the multimedia screen.

Adjusting the seatback

To tilt the seatback, move the top of switch **2** forwards or backwards.

Adjusting the lumbar support on the driver's seat

Move the switch **3** forwards, backwards, upwards or downwards.

FRONT SEATS

Adjusting the seat position



To move the seat forwards or back

Move the switch **4** forwards or backwards.

To raise or lower the seat base

Move the rear of the switch **4** upwards or downwards.



For safety reasons, carry out any adjustments while the vehicle is stationary.

We would advise you not to recline the seatbacks too far to ensure that the effectiveness of the seat belts is not reduced. Nothing should be placed on the floor (area in front of the driver) as these objects may slide under the pedals during sudden braking manoeuvres, thus obstructing their use.

Heated seats

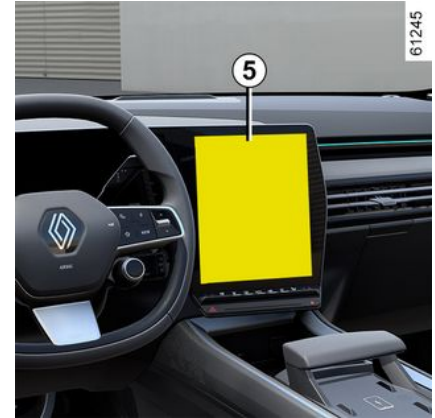

With the ignition on, you can activate the heated seats via the multimedia screen **5**:

- pressing the  pictogram on the required seat for the first time activates the heating system at maximum power. Three warning lights appear as part of the pictogram;
- a second press decreases the heating to medium power. Two integrated warning lights are illuminated;

FRONT SEATS

2



- a third press decreases the heating to minimum power. One integrated warning light is illuminated;
- a fourth press turns the heating off.

In order to avoid unnecessary energy consumption, the heated passenger seat can be deactivated automatically in the absence of an occupant.

"Favourites" function

Depending on the vehicle, by pressing the steering wheel control **6**, you can activate the heated seats according to the stored user settings that you have previously defined.

For more information on programming this function, please refer to the multimedia instructions.

Operating faults

If an operating fault is detected, the warning lights on the pictogram for the seat concerned will flash on the multimedia screen **5**.

Consult an approved dealer.

Functions



A number of seat functions are available from the multifunction screen, depending on the vehicle.

On equipped vehicles, the switch **1** provides direct access to the "Seats" menu on the multimedia screen.

Massage seats

(depending on the vehicle)

You can activate the "Massage" function (Active Lumbar) on the driver's seat or, depending on the vehicle, on the front passenger seat.



With the ignition on, from the multimedia screen select the "Vehicle" world **2**, then "Seats" followed by "Massage".

Browse the "Driver" menu for:

- select the Active Lumbar massage type:
 - "Low";
 - "Extended";
 - "Alternative";
- adjust the intensity;
- activate/deactivate the massage seat.

FRONT SEATS

Press and hold the switch **1** of the seat on which you would like to activate the "Massage" function, according to the defined parameters.

Settings

Refer to the multimedia instructions for information on accessing the settings.

You can activate or deactivate the following elements:

- easy driver/passenger access;
- visual feedback of current movement.

Note: if the "Guest" user profile is in use then the automatic adjustment functions will not be available.

Easy Seat Access

When this function is activated, the seat automatically moves back when the driver and/or passenger leaves the vehicle, and returns to its position the next time the vehicle starts.

Note: the function is deactivated if one of the adjustment buttons is pressed while the seat is moving.



Deactivate the "Easy Access Seat" function before installing a child seat on the front passenger seat and/or on the rear seats.

Risk of injury.

Driving position: storage

It is possible to save the driving position for the driver's seat and/or passenger seat → **131**.

REAR SEATS

Rear headrests

Position for use



The side headrests and centre headrest are not adjustable.

Note: the central headrest is fixed.

To remove the headrest



Pull on strap **1** to tilt the bench seat-back forwards, then remove the headrest.

To refit the headrest

Pull on strap **1** to tilt the bench seat-back forwards, then insert the rods into the holes and push the headrest down until it locks. Check that the bonnet is correctly locked.

Rear bench seat

Functions

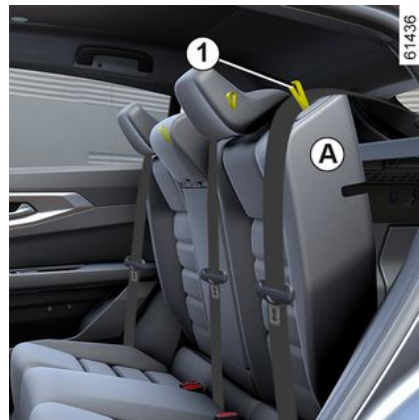

To fold down the seatback

Ensure that the front seats are far enough forward.

Before folding down a seatback, fasten the rear side seat belts. This prevents the seat belt from locking when the seatback is lifted up again.

Pull the strap **1** and lower the seatback **A**.

To raise the seatback

Proceed in reverse order.

REAR SEATS

Raise the seatback again until it reaches the locking joint of the seatback. Be careful not to jam the seat belt between the seatback and the parcel shelf.

Check the operation of the seat belt.



When refitting the seatback, make sure it is correctly locked in place.

If seat covers are fitted, make sure these do not prevent the seatback latch from locking in.

Make sure that the seat belts are positioned correctly.

Reposition the headrests.



With the central seat lowered, before lowering a side seat ensure that no body parts (arms, hands, fingers, etc.) are protruding and/or near the locking system **2**.

Risk of trapping.

Central rear armrest



Pull the strap **2**.

The rear central armrest **3** is equipped with two cup holders **4**.

Note:

do not use the central rear seat while the central armrest is lowered.



2

SEAT BELTS

Seat belts

Always wear your seat belt when travelling in your vehicle. You must also comply with the legislation of the particular country you are in.

Before starting, first adjust your driving position, then ask all occupants to adjust their seat belts to ensure optimum protection.

Adjusting your driving position

- **Sit well back in your seat** (having removed your coat or jacket, etc.). This is essential to ensure that your back is positioned correctly;
- **adjust the distance between the seat and the pedals.** Your seat should be as far back as possible while still allowing you to fully depress the pedals. The seatback should be adjusted so that your arms are slightly bent when you hold the steering wheel;
- **adjust the position of your headrest.** For maximum safety, your head must be as close as possible to the headrest;
- **adjust the height of the seat.** This adjustment allows you to select the seat position which offers you the best possible view;
- **adjust the position of the steering wheel.**



Make sure that the rear bench seat → 78 is locked in position correctly so that the rear seat belts will operate correctly.



Incorrectly adjusted or twisted seat belts may cause injuries in the event of an accident.

Use one seat belt per person, whether child or adult.

Even pregnant women should wear a seat belt. In this case, ensure that the lap belt is not exerting too much pressure on the abdomen, but do not allow any slack.

Adjusting the seat belts



To ensure the correct adjustment and positioning of the seat belts on all seats:

- adjust the seats (seat position and seatback angle, if available);
- sit with your back firmly against the seatback;
- move the shoulder strap **1** as close as possible to the base of the neck without it actually resting against it (if necessary, adjust the height of the seat belt if available) and make sure that the shoulder strap **1** is in contact with the shoulder;
- position the lap belt **2** so that it lies flat on the thighs and against the pelvis.

SEAT BELTS

The seat belt must be worn as close to the body as possible. e.g. avoid wearing heavy clothing, keeping bulky objects under the belts, etc.

Locking

Unwind the belt **slowly and smoothly** and ensure that the buckle **3** locks into the catch **5** (check that it is locked by pulling on the buckle **3**).

If the belt jams, allow it to return slightly before attempting to unwind it again.

If your seat belt is completely jammed, pull slowly, but firmly, so that just over 3 cm unwinds. Allow it to return slightly before attempting to unwind it again.

If there is still a problem, contact an approved dealer.

Unlocking

Press the button **4** and the seat belt will be rewound by the inertia reel. Guide the belt.



Seat belt reminder warning lights

This warning light appears on the central display **A** when the vehicle ignition is switched on and if the driver's and/or front passenger's seat belt(s) (if the passenger seat is occupied) is not fastened.



Front seat belt reminder



With the doors closed, the graphic **6** is displayed on the instrument panel for approximately 60 seconds when the vehicle ignition is switched on. This informs the driver of the fastening status of each of the front seat belts every time:

- the doors are opened during driving (vehicle speed above zero);
- a front seat belt is fastened/unfastened.

Understanding the graphic **6**:

- symbol in green: seat belt fastened;
- symbol in red: the seat is occupied and the seat belt is not fastened;
- symbol in grey: seat not occupied.

With the doors closed, the  warning light appears on the central display when the vehicle ignition is switched on if the driver's and/or front passenger's seat belt(s) (if this seat is occupied) are not fastened.

When the vehicle speed is less than approximately 12 mph (20 km/h), the



warning light appears on the central display if a front seat is occupied and the seat belt is not fastened.

It is accompanied by the graphic **6** which appears for approximately 60 seconds each time one of the front seat belts is fastened or unfastened.

SEAT BELTS

When the vehicle speed exceeds approximately 12 mph (20 km/h), if one of the front seat belts is or becomes unfastened during the journey:

- the  warning light flashes on the central display;
- and
- a beep sound for approximately 120 seconds;
- and
- the graphic **6** is displayed for approximately 180 seconds and the symbol for the seat concerned changes to red.

Always make sure that the front passengers are properly fastened in and that the number of seat belts indicated as fastened corresponds to the number of front seats occupied.

Note: an object placed on the passenger seat may activate the warning light in some cases.

Rear seat belt reminder

With the doors closed, the graphic **6** is displayed on the instrument panel for approximately 60 seconds when the vehicle ignition is switched on. This informs the driver of the fastening status of each of the rear seat belts every time:

- the doors are opened during driving (vehicle speed above zero);
- a front seat belt is fastened/unfastened.

Understanding the graphic **6**:

- symbol in green: seat belt fastened;
- symbol in red: the seat is occupied and the seat belt is not fastened;
- symbol in grey: seat not occupied.

Depending on the vehicle, with the doors closed the  warning light on the central display also appears when the ignition is switched on and if a rear seat is occupied and the seat belt is not fastened.

When the vehicle speed is less than approximately 12 mph (20 km/h), the

 warning light on the central display appears when a rear seat belt is unfastened.

It is accompanied by the graphic **6** which appears for approximately 60 seconds each time one of the rear seat belts is fastened or unfastened.

When the vehicle speed exceeds approximately 12 mph (20 km/h), if one of the rear seat belts is or becomes unfastened during the journey:

- the  warning light flashes on the central display;

and

- a beep sounds for around 30 or 120 seconds;

and

- the graphic **6** is displayed for at least 60 seconds or, depending on the vehicle, approximately 180 seconds and the symbol for the seat concerned changes to red.

Always make sure that the rear passengers are properly fastened and that the number of fastened seat belts indicated corresponds to the number of rear seats occupied.

Note: an object placed on one of the rear passenger seat bases may activate the warning light in some cases.

SEAT BELTS

Adjusting the height of the front seat belts

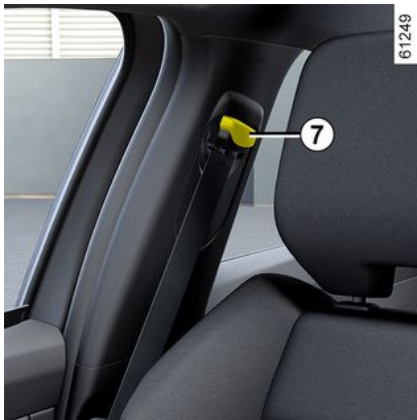

Press the button **7** to adjust the seat belt height, so that the shoulder strap is worn as shown previously. Press the button **7** and raise or lower the seat belt. Make sure that the seat belt is locked in position correctly after you have adjusted it.

Rear side seat belts 8



The belts are fastened, unfastened and adjusted in the same way as the front belts.



Check that the rear seat belts are positioned and operating correctly each time the rear bench seat is moved.

Rear centre seat belt 9

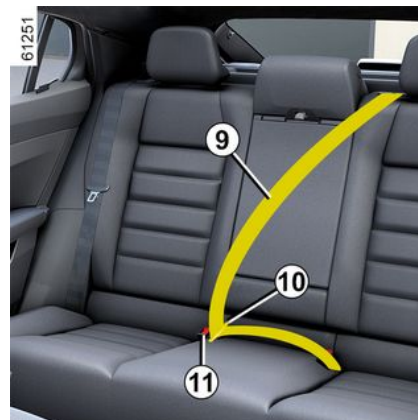

Slowly unwind the belt **9**.

Fasten the buckle **10** into the red catch unit **11**.



Ensure that you always leave the buckle **10** fastened in the catch **11** even if no passenger is present in the centre seat.

SEAT BELTS

Warnings

2

The following information applies to the vehicle's front and rear seat belts.



- No modification must be made to the originally-fitted restraint system components (seat belts, seats and their mountings). For special operations (e.g. fitting a child seat), please contact an approved dealer.
- Do not use devices which give any slack in the belts (e.g. clothes pegs, clips, etc.), as a seat belt which is worn too loosely risks causing injury in the event of an accident.
- Never wear the shoulder strap under your arm or behind your back.
- Never use the same belt for more than one person and never hold a baby or child on your lap with your seat belt around them.
- The belt should never be twisted.
- Following an accident, have the seat belts checked and replaced if necessary. Always replace your seat belts as soon as they show any signs of wear.
- When the rear bench seat is being put back, make sure that the seat belts and buckles are correctly positioned so that they can be used properly.
- Make sure that the seat belt buckle is inserted into the appropriate catch.
- Ensure that no objects are placed in the area around the seat belt catch as they could prevent it from being properly secured.
- Make sure the seat belt catch is properly positioned (it should not be hidden away, crushed or flattened by people or objects).

ADDITIONAL SAFETY DEVICES

Methods of restraint in addition to the front seat belts

Depending on the vehicle, they may comprise:

- **seat belt inertia reel pretensioners;**
- **lap seat belt pretensioners;**
- **chest force limiters;**
- **airbags driver and passenger front.**

These systems are designed to act independently or together when the vehicle is subjected to a frontal impact.

Depending on the severity of the impact, the system can cause:

- blocking of the seat belt;
- the seat belt inertia reel pretensioner which is triggered to correct seat belt slack;
- the lap seat belt pretensioner to hold the occupant in their seat;
- the frontairbag .

Pretensioners

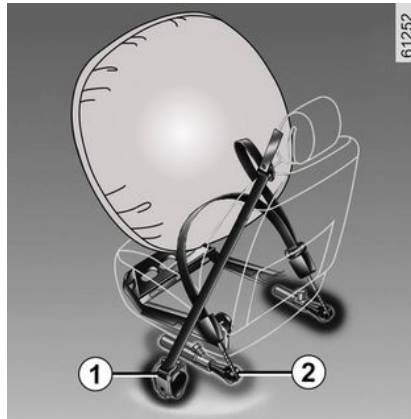

The pretensioners hold the seat belt against the body, holding the occupant more securely against the seat, thus increasing the seat belt's efficiency.

In the event of a severe frontal impact and if the ignition is switched on, the system may engage the following depending on the force of the impact:

- the seat belt inertia reel pretensioner **1** which instantly retracts the seat belt;
- the lap seat belt inertia reel pretensioner **2** on the front seats.



- Have the entire restraint system checked following an accident.
- No operation whatsoever is permitted on any part of the system (pretensioners, airbags, computers, wiring) and the system components must not be reused on any other vehicle, even if identical.
- Only qualified personnel from our Network may work on the pretensioners and airbags, otherwise the system may trigger accidentally and cause injury.
- The electrical trigger system may only be tested by a specially trained technician using special equipment.
- If scrapping your vehicle, contact an approved dealer for disposal of the gas generator of the pretensioners and airbags.

Load limiter

Above a certain severity of impact, this mechanism is used to limit the force of the belt against the body so that it is at an acceptable level.

ADDITIONAL SAFETY DEVICES

Driver and passenger front airbags

Fitted to the driver and passenger sides.

A symbol on the lower section of the windscreen indicates if this equipment is present (depending on the vehicle).

Each airbag system consists of:

- an airbag and gas generator fitted on the steering wheel for the driver and in the dashboard for the front passenger;
- an electronic unit for monitoring the system controlling the gas generator electrical trigger;
- remote sensors;
- a single  warning light on the instrument panel.



The airbag system uses pyrotechnic principles.

This explains why, when the airbag inflates, it will generate heat, produce smoke (this does not mean that a fire is about to start) and sound like a detonation. In a situation where an airbag deployment is required, it will inflate immediately and this may cause some minor, superficial grazing to the skin or other problems.

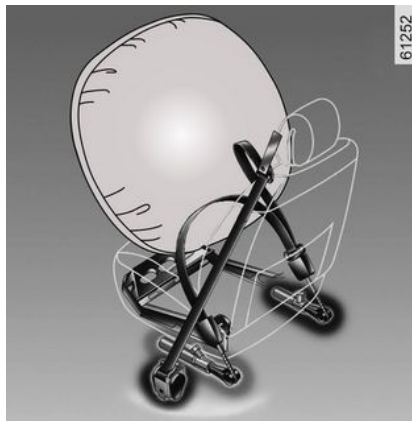

Operation

This system is only operational when the ignition is switched on.

In a severe frontal impact, the airbags inflate rapidly, cushioning the impact of the driver's head and chest against the steering wheel and of the front passenger against the dashboard. The airbags then deflate immediately so that the passengers are not in any way prevented from leaving the vehicle.

Operating faults



This warning light comes on when the engine is started and then goes out after approximately three seconds.

If it does not come on when the ignition is switched on or if it stays on, there is a fault in the system.

Contact your approved Dealer as soon as possible;

Your protection will be reduced until this fault is rectified.

ADDITIONAL SAFETY DEVICES

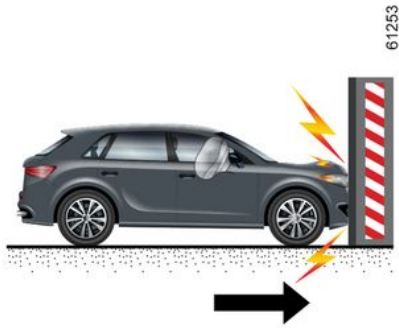

The following cases trigger the pretensioners or airbags .

In a frontal impact against a rigid (non-deformable) surface at an impact speed equal to or greater than 16 mph (25 km/h).

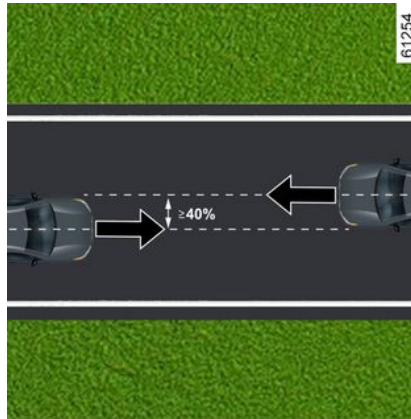

In the event of a frontal impact with another vehicle of an equivalent or higher category, with an impact area equal to or greater than 40%, where the speed of both vehicles is equal to or greater than 25 mph (40 km/h).

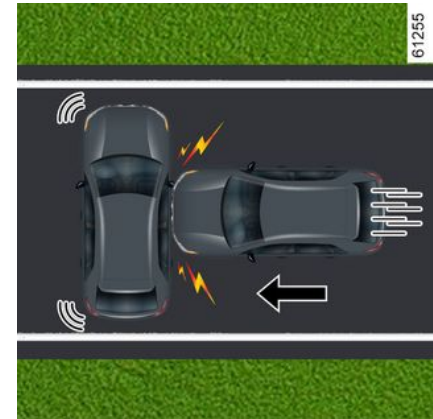

In a side impact with another vehicle of an equivalent or higher category, at an impact speed equal to or greater than 31 mph (50 km/h).

ADDITIONAL SAFETY DEVICES

2

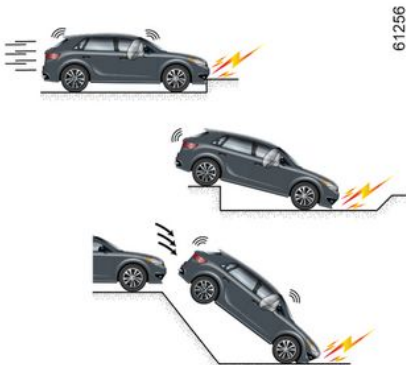

The pretensioners or airbags may be triggered in the following cases:

- an impact underneath the vehicle (e.g. pavement kerb);
- potholes;
- a drop or hard landing;
- stones;
- ...



In the following cases, the pretensioners or airbags might not be triggered:

- a rear impact, however severe;
- the vehicle overturning;



- side impact at the front or rear of the vehicle;
- frontal impact, underneath the tail of a lorry;
- frontal impact against an obstacle with a sharp angle;
- ...

ADDITIONAL SAFETY DEVICES

Warnings

All of the following warnings are intended to ensure that the airbag is not obstructed in any way when it is inflated and also to prevent the risk of serious injury caused by objects which may be projected when it inflates.

2



Warnings in relation to the driver's airbag

- Do not modify the steering wheel or the boss.
- Do not cover the steering wheel boss under any circumstances.
- Do not attach any objects (badge, logo, watch, telephone cradle, etc.) to the steering wheel boss.
- The steering wheel must not be removed (except by qualified personnel from our Network).
- Do not sit too close to the steering wheel: sit with your arms slightly bent (see "Adjusting your driving position" → 80). This will allow sufficient space for the airbag to deploy correctly and be fully effective.

Warnings in relation to the passenger's airbag

- Do not attach or glue any objects (badge, logo, clock, telephone holder, etc.) to the dashboard over or near the airbag.
- Do not place anything between the dashboard and the passenger (animal, umbrella, walking stick, parcels, etc.).
- The passenger must not put his or her feet on the dashboard or seat as there is a risk that serious injuries may be sustained. As a general rule, parts of the body should be kept away from the dashboard (knees, hands, head, etc.).
- the devices in addition to the front passenger seat belt should be reactivated as soon as a child seat is removed, to ensure the protection of the passenger in the event of an impact.

A REAR-FACING CHILD SEAT MUST NOT BE FITTED TO THE FRONT PASSENGER SEAT UNLESS THE ADDITIONAL RESTRAINT SYSTEMS ARE NOT DEACTIVATED → 112.

ADDITIONAL SAFETY DEVICES

2

Methods of restraint in addition to the rear seat belts

Depending on the vehicle, they may comprise:

- **side seat belt inertia reel pretensioners;**
- **chest force limiters.**

These systems are designed to act independently or together when the vehicle is subjected to a frontal impact.

Depending on the severity of the impact, the system can cause:

- blocking of the seat belt;
- the seat belt inertia reel pretensioner (which engages to correct seat belt slack).

Load limiter

Above a certain severity of impact, this mechanism is used to limit the force of the belt against the body so that it is at an acceptable level.

Side seat belt pretensioners

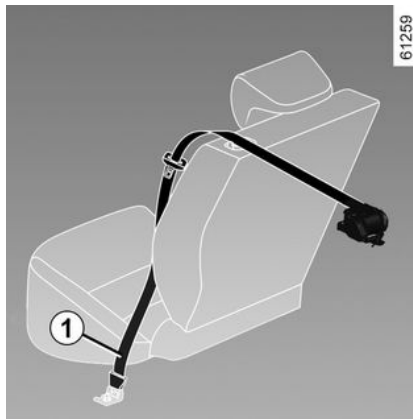

The pretensioners hold the seat belt against the body, holding the occupant more securely against the seat, thus increasing the seat belt's efficiency.

With the ignition on, following a significant frontal impact and depending on the severity of the impact, the system may trigger the seat belt inertia reel pretensioner **1** which instantly retracts the seat belt.



– Have the entire restraint system checked following an accident.

– No operation whatsoever is permitted on any part of the system (pretensioners, airbags, computers, wiring) and the system components must not be reused on any other vehicle, even if identical.

– Only qualified personnel from our Network may work on the pretensioners and airbags, otherwise the system may trigger accidentally and cause injury.

– The electrical trigger system may only be tested by a specially trained technician using special equipment.

– If scrapping your vehicle, contact an approved dealer for disposal of the gas generator of the pretensioners and airbags.

Side protection devices

Side airbag

This airbag may be fitted to each of the front seats and is activated on the door

ADDITIONAL SAFETY DEVICES

side of the seats to protect the occupants in the event of a severe side impact.

Curtain airbag

This airbag fitted (depending on the vehicle) along the upper sides of the vehicle – they inflate along the front and rear door side windows to protect the passengers in the event of a severe side impact.

Central airbag

This airbag fitted to the driver's seat and deployed between the driver's seat and the passenger seat in order to protect the driver and passenger in the event of a severe side impact.

It also spreads out to protect the driver, if they are the only one in the front, in the event of a severe side impact.

ADDITIONAL SAFETY DEVICES

Warnings

2



Warning relating to the passengerairbag side airbag and theairbagcentral airbag

- **Fitted with covers:** seats equipped with anairbag require vehicle-specific covers. Contact an approved dealer to find out if these covers are available. The use of any covers other than those designed for your vehicle (including those designed for another vehicle) may affect the operation of the airbag and compromise your safety.
- Do not place any accessories, objects or even pets between the seatback, the door and the internal fittings. Do not cover the seatback with objects such as clothes or accessories. This could hinder the operation of theairbag or lead to injury during inflation.
- Do not place any object(s) on the central armrest compartment cover as this could hinder the operation of theairbag and/or lead to injury during inflation.
- Do not leave any object(s) protruding from the central armrest compartment as this could hinder the operation of theairbag and/or lead to injury during inflation.
- No work or modification whatsoever may be carried out on the seat or internal fittings, except by qualified personnel from our Network.
- The slits on the front seatbacks (door side and centre console side) correspond to the airbags deployment zone: never insert any objects into these slits.

ADDITIONAL SAFETY DEVICES

Additional methods of restraint

All of the following warnings are intended to ensure that the airbag is not obstructed in any way when it is inflated and also to prevent the risk of serious injuries caused by items which may be projected when it inflates.

2



The airbag is designed to complement the action of the seat belt. Both the airbag and the seat belt are integral parts of the same protection system. It is therefore essential to wear seat belts at all times. If seat belts are not worn, the occupants are exposed to the risk of serious injury in the event of an accident. It may also increase the risk of minor superficial injuries occurring when the airbag is deployed, although such minor injuries are always possible with airbags.

If the vehicle should overturn or suffer a rear impact, however severe, the pretensioners and airbags are not always triggered. Shocks to the underbody of the vehicle, from pavements, potholes, stones etc. can all trigger these systems.

- Any work or modification on any part of the airbag (airbags, pretensioners, computer, wiring harness, etc.) **is strictly prohibited** (except by qualified personnel from the network).
- To ensure that the system is in good working order and to avoid accidental triggering of the system which may cause injury, only qualified personnel from the network may work on an airbag system.
- As a safety precaution, have the airbag system checked if your vehicle has been involved in an accident, or is stolen or broken into.
- When selling or lending the vehicle, inform the new purchaser of these conditions when handing over this vehicle user manual.
- When scrapping your vehicle, contact your approved dealer for disposal of the gas generator(s).

CHILD SAFETY

General information

2

Carrying children

Please ensure that you comply with the legislation of your country.

Children, and adults, must be correctly seated and strapped in for all journeys. The children being carried in your vehicle are your responsibility.

A child is not a miniature adult. Children are at risk of specific injuries as their muscles and bones have not yet finished growing. The seat belt alone would not provide suitable protection. Use an approved child seat and ensure you use it correctly.



To prevent the doors being opened, use the "Child lock" feature → 61.



A collision at 31 mph (50 km/h) is the same as falling a distance of 10 metres. Transporting a child without a restraint is the equivalent of allowing him or her to play on a fourth-floor balcony without railings. Never travel with a child held in your arms. In the event of an accident, you will not be able to keep hold of the child, even if you yourself are wearing a seat belt. If your vehicle has been involved in a road accident, replace the child seat and check the seat belts and anchorage points ISOFIX.



Driver's responsibility when parking or stopping the vehicle

Never leave an animal, child or adult who is not self-sufficient alone in your vehicle, even for a short time. They may pose a risk to themselves or to others by starting the engine, activating equipment such as the electric windows or by locking the doors. Also, in hot and/or sunny weather, please remember that the temperature inside the passenger compartment increases very quickly. **RISK OF DEATH OR SERIOUS INJURY.**

Using a child seat

The level of protection offered by the child seat depends on its ability to restrain your child and on its installation. Incorrect installation compromises the protection it offers the child in the event of harsh braking or an impact.

Before purchasing a child seat, check that it complies with the regulations for the country you are in and that it can be fitted in your vehicle. Consult an ap-

CHILD SAFETY

proved Dealer to find out which seats are recommended for your vehicle.

The regulations on transporting children are specific to each country. The use of a child seat depends on the age and/or the size and/or weight of the child.

For children who do not need to be transported in a child seat, make sure that the seat belt is correctly adjusted and fastened.

In all cases, you must comply with the regulations of the particular country you are in.

Before fitting a child seat, read the manual and respect its instructions. If you experience any difficulties during installation, contact the manufacturer of the equipment. Keep the instructions with the seat.



Set a good example by always fastening your seat belt and teaching your child:

- to strap themselves in correctly,
- to always get in and out of the car at the kerb, away from busy traffic.

Do not use a second-hand child seat or one without an instruction manual.

Check that there are no objects in the vicinity of the child seat which could impede its operation.



Never leave a child unattended in the vehicle.

Check that your child is always strapped in and that the belt or safety harness used is correctly set and adjusted.

Avoid wearing bulky clothing which could cause the belts to slacken → 80.

Never let your child put their head or arms out of the window.

Check that the child is in the correct position for the entire journey, especially if asleep.



Before installing a child seat on one of the rear seats, ensure that the "Easy Access Seat"

function is deactivated for the driver's and/or front passenger seats.

For more information on the settings and functions for the front seats, consult your vehicle user manual.

CHILD SAFETY

Choosing a child seat

Rear-facing child seats

2



61260

A baby's head is, proportionally, heavier than that of an adult and its neck is very fragile. Transport the child in this position as long as possible (until the age of 2 at the very least). It supports both the head and the neck.

Choose a bucket type seat for best side protection and change it as soon as the child's head is higher than the shell.

Forward-facing child seats



61261

Up to 18 kg or 4 years, the child may travel on a forward-facing seat.

Choose a seat according to the child's size: their head and abdomen are the areas which require most protection. A forward-facing child seat which is firmly attached to the vehicle will reduce the risk of impact to the head. Ensure your child travels in a forward-facing seat with a harness for as long as their size permits.

Choose a bucket type seat for optimum side protection.w

Booster cushions



61262

From 15 kg or 4 years, the child can travel using a booster seat, which will enable the seat belt to be adapted to suit his size and shape. The booster seat cushion must be fitted with guides to position the seat belt on the child's thighs rather than the stomach. It is recommended that you use a seatback which can be adjusted in terms of height to position the seat belt in the centre of the shoulder. It must never rest on the neck or on the arm.

Choose a bucket type seat for optimum side protection.w

CHILD SAFETY

Choosing a child seat mounting

There are two ways to attach child seats: using the seat belt or using the ISOFIX system.

Attachment via the seat belt

The seat belt must be adjusted in order to ensure it works in the event of sudden braking or impact.

Ensure that the strap paths indicated by the child seat manufacturer are observed.

Always check that the seat belt is correctly fastened by pulling it up, then pulling it out fully whilst pressing on the child seat.

Check that the seat is correctly held by moving it from side to side and back to front: the seat should remain firmly fixed.

Check that the child seat has not been installed at an angle and that it is not resting against a window.



Do not use the child seat if it risks unfastening the seat belt restraining it: the base of the seat must not rest on the buckle and/or catch of the seat belt.



The seat belt must never be twisted or the tension relieved. Never pass the shoulder strap under the arm or behind the back. Check that the seat belt has not been damaged by sharp edges. If the seat belt does not operate normally, it will not protect the child. Consult an approved dealer. Do not use this seat until the seat belt has been repaired.

Attachment using the ISOFIX system

Authorised child seats ISOFIX are approved in accordance with current regulations if any of the four cases below applies:

- Universal ISOFIX 3-point forward-facing seat;
- Semi-universal ISOFIX 2-point seat;
- vehicle-specific;
- i-Size which has either:
 - a strap which attaches to the third ring of the seat concerned;
 - or a strut that rests on the vehicle floor, compatible with the i-Size approved seat, the role of which is to prevent the child seat from moving in the event of a collision.

In the latter three cases check that your child seat can be installed by consulting the list of compatible vehicles.



No modifications must be made to the component parts of the originally fitted restraint system (seat belts, ISOFIX, seats and their mountings).

Attach the child seat with the ISOFIX locks, if these are provided. The ISOFIX system allows quick, easy and safe fitting.

The ISOFIX system consists of two rings and, in some cases, a third ring.

CHILD SAFETY

2



The ISOFIX anchorage points have been exclusively designed for child seats with the ISOFIX system. Never fit a different type of child seat, seat belt or other objects to these fittings. Check that nothing is obstructing the anchorage points. If your vehicle has been involved in a road accident, have the ISOFIX anchorage points checked and replace your child seat.



Before using an ISOFIX child seat that you purchased for another vehicle, check that its installation is authorised. Consult the list of vehicles which can be fitted with the seat with the equipment manufacturer.



61263

The two rings **1** are located between the seatback and the seat base and

are identified by a  mark.

To access the rings **1**, open the zip-pers.

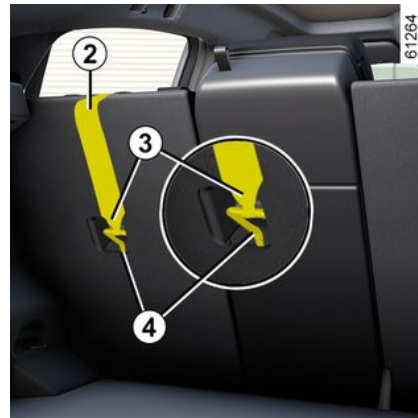

61264

The third ring **4** is used to attach the upper strap on some child seats. **2** on some child seats.

Rear seats

The upper strap **2** should be positioned between the seatback and the rear parcel shelf. To do so, remove the rear parcel shelf → **328**.

Attach the hook **3** to one of the rings **4** marked by the  symbol.

CHILD SAFETY

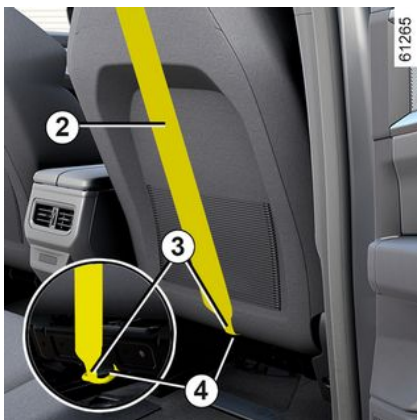

Front passenger seat

Attach the hook **3** of the upper strap **2**

to the ring **4** identified by the  symbol.

All seats

Pull the upper strap **2** so that the back of the child seat comes into contact with the back of the vehicle seat.



The ISOFIX anchorage points have been exclusively designed for child seats with the ISOFIX system. Never fit a different type of child seat, seat belt or other objects to these fittings. Check that nothing is obstructing the anchorage points. If your vehicle has been involved in a road accident, have the ISOFIX anchorage points checked and replace your child seat.



Check that the seatback of the forward-facing child seat is in contact with the seatback of the vehicle seat. In this case, the child seat may not always rest on the seat base of the vehicle seat.

CHILD SEATS

Fitting a child seat, general information

Some seats are not suitable for fitting child seats. The diagram indicates where to fit a child seat.



Fit the child seat in a rear seat wherever possible.

Make sure the child seat or the child's feet do not prevent the front seat from locking correctly → 73.

Check that when installing the child seat in the vehicle it is not at risk of coming loose from its base. If you have to remove the headrest, check that it is correctly stored so that it does not come loose under harsh braking or impact.

Always attach the child seat to the vehicle even if it is not in use so that it does not come loose under harsh braking or impact.

The types of child seats indicated may not be available. Before using a differ-

ent child seat, check with the manufacturer that it can be fitted.

In the front seat

The laws concerning children travelling in the front passenger seat differ in every country. Consult the legislation in force and follow the indications on the installation table and diagram.

Before fitting a child seat in this seat (if authorised):

- lower the seat belt as far as possible;
- move the seat as far back as possible;
- gently tilt the seatback away from the vertical position (approximately 25°);
- on equipped vehicles, raise the seat base as far as possible.

Always fully raise the seat headrest so that it does not interfere with the child seat → 73.

After installing the child seat, when this is possible, you can move the vehicle seat forward if necessary (so as to leave enough space in the rear seats for passengers or other child seats). For a rear-facing child seat, do not let it touch the dashboard or move it to the furthest forward position.

Do not change other settings after installing the child seat.



RISK OF DEATH OR SERIOUS INJURY: before fitting a rear-facing child seat on the front passenger seat, check that the airbag has been deactivated → 112.

In the rear side seat

A carrycot can be installed across the vehicle and will take up at least two seats. Position the child with his or her feet nearest the door.

In order to install a rear-facing child seat, move the front seat as far forward as possible, then move the front seat back as far as it will go, without allowing it to come into contact with the child seat.

For the safety of the child in the forward-facing position:

- move the seat in which the child will be seated as far back as possible;
- Move the seat in front of the child forwards, and set the position of the seatback to avoid contact between the seat and the child's legs.

CHILD SEATS



Ensure that the child seat or the child's feet do not prevent the locking in place of the seat in front

→ 78 and → 73.



Before installing a child seat on one of the rear seats, ensure that the "Easy Access Seat"

function is deactivated for the driver's and/or front passenger seats → 131.

RISK OF INJURY.



Fitting a seat ISOFIX in the rear-left seat means the middle seat cannot be used. The central seat belt will no longer be either accessible or useable.



Fit the child seat in a rear seat wherever possible.

To install an ISOFIX seat in this seat, unbuckle the seat belt by hand before engaging the bolts.

In all situations, remove the headrest of the rear seat on which the child seat is positioned → 78. If necessary, position the rear seat as far back as possible. This must be done before fitting the child seat. Check that the child seat is resting against the back of the rear seat.

Installing a booster seat (group 2 or 3)

Check that the seat belt → 80 operates (winds) correctly.

Adjust the seat belt by positioning:

- the shoulder strap on the child's shoulder without touching the neck;
- the lap strap so that it lies flat on the thighs and against the pelvis.

If necessary, adjust the position of the vehicle seat.

CHILD SEATS

Attachment by seat belt

2

Fitting diagram

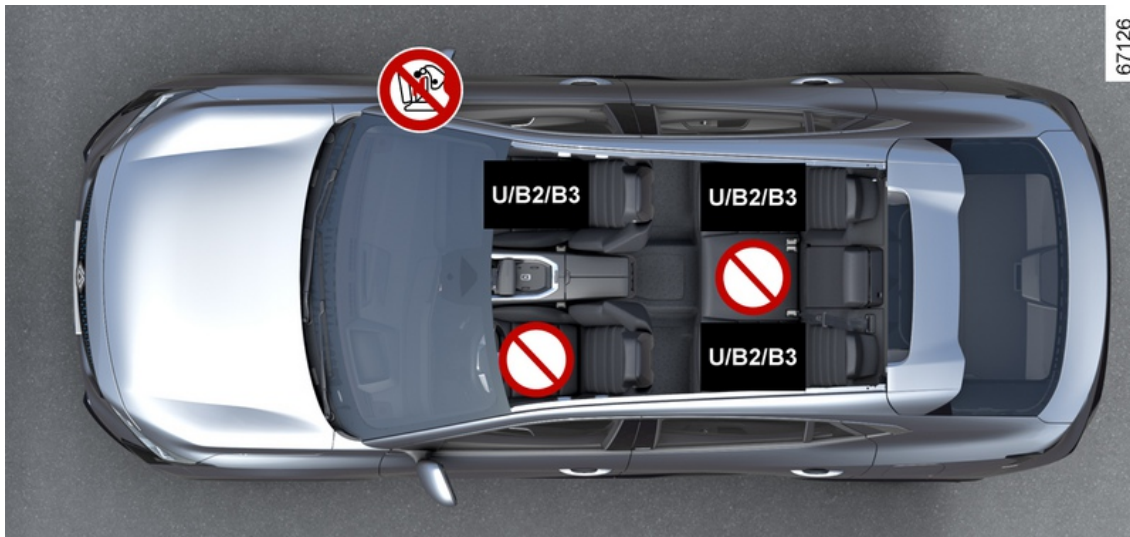

CHILD SEATS



RISK OF DEATH OR SERIOUS INJURY: before fitting a rear facing child seat on the front passenger seat, check that the airbag has been deactivated → 112.

2



Check the status of the airbag before fitting a child seat or allowing a passenger to use the seat.



Seat not suitable for fitting child seats.

Child seat attached using the belt



Seat which allows a child seat with "Universal" approval to be attached by a seat belt.



Seat enabling a child seat with "B2" approval to be fitted.



Seat enabling a child seat with "B3" approval to be fitted.



Using a child safety system which is not approved for this vehicle will not properly protect the baby or child. They risk serious or even fatal injury.



Check that your child is always strapped in and that the belt or safety harness used is correctly set and adjusted → 80.

If necessary, adjust the seat position accordingly.

CHILD SEATS

Installation table

The table below summarises the information shown on the following diagram in order to ensure the regulations in force are respected.

Type of child seat	Weight of the child	Front passenger seat (6)		Rear side seats (6)	Rear centre seat (6)
		With airbag deactivated	With airbag activated		
Carrycot fitted across the vehicle Group 0	< 10 kg	X	X	U (2)	X
Rear-facing shell seat Groups 0 or 0 +	< 10 kg and < 13 kg	U (1) (5)	X	U (3)	X
Shell seat/rear-facing seat Groups 0+ and 1	< to 13 kg and 9 to 18 kg	U (1) (5)	X	U (3)	X
Forward-facing seat Group 1	9 to 18 kg	X	U (5)	U (3) (4)	X
Booster seat Groups 2 and 3	15 to 25 kg and 22 to 36 kg	X	U , B2 , B3 (5)	U , B2 , B3 (3) (4)	X



(1) RISK OF DEATH OR SERIOUS INJURY: before fitting a rear-facing child seat in the front passenger seat, check that the airbag has been deactivated → 112.

X = Seat not suitable for fitting child seats of this type.

U = Seat enabling a child seat with "Universal" approval to be attached by seat belt: check that it can be fitted.

B2 = Seat enabling a child seat with "B2" approval to be attached by seat belt: check that it can be fitted.

CHILD SEATS

B3 = Seat enabling a child seat with "B3" approval to be attached by seat belt: check that it can be fitted.

(2) A carrycot can be installed across the vehicle and it will take up at least two seats. Position the child with his or her feet nearest the door.

(3) If necessary, position the vehicle seat as far back as possible and raise the seatback (by approximately 25°). In order to install a rear-facing child seat, move the front seat as far forward as possible, then move the front seat back as far as it will go, without allowing it to come into contact with the child seat.

(4) In all situations, remove the headrest of the rear seat on which the child seat is positioned. This must be done before fitting the child seat. Move the seat in front of the child forwards, move the seatback forward to avoid contact between the seat and the child's legs.

(5) Raise the seat to the maximum and position it as far back as possible, tilting the seatback slightly (approximately 25°).



(6) Deactivate the "Easy Access Seat" function before installing a child seat on the front passenger seat and/or on the rear seats.

Risk of injury.

CHILD SEATS

Attachment using the ISOFIX system

2

Fitting diagram

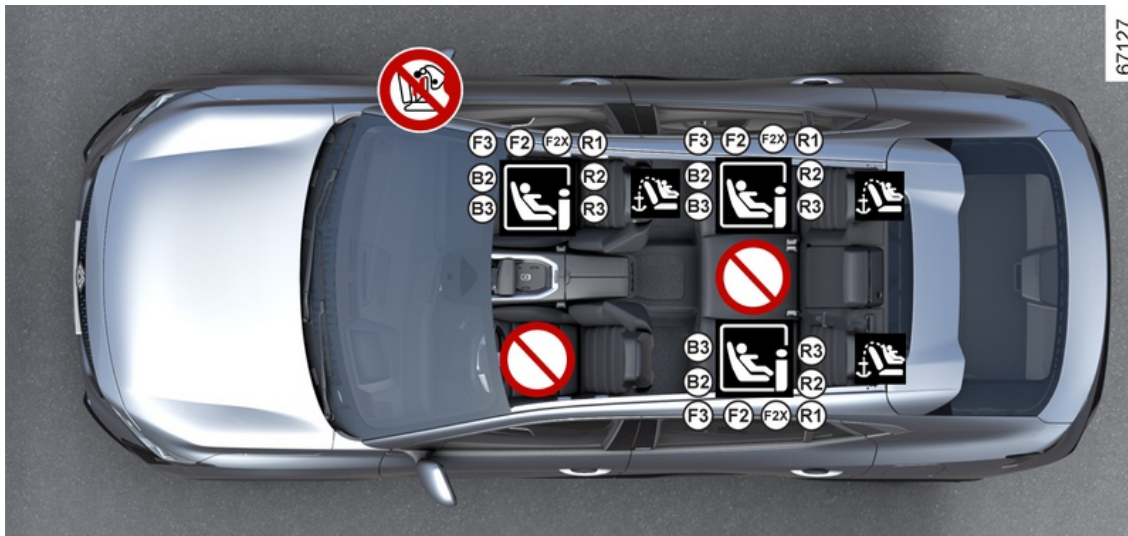

CHILD SEATS



RISK OF DEATH OR SERIOUS INJURY:

before fitting a rear facing child seat on the front passenger seat, check that the airbag has been deactivated
→ 112.



For the front passenger seat, the use of a child seat with a floor support is recommended to avoid triggering the seat belt warning signal.



Seat which does not allow a child seat to be fitted.

Child seat attached using the ISOFIX system



Seat which allows an ISOFIX child seat to be fitted.



The rear seats are fitted with an anchorage point which allows a forward-facing ISOFIX child seat with universal approval to be attached. The anchoring points are located on the passenger seatback for the front seat and on the bench seatback for the rear seats.



Using a child safety system which is not approved for this vehicle will not properly protect the baby or child. They risk serious or even fatal injury.



Fit the child seat in a rear seat wherever possible.

To install an ISOFIX seat in this seat, unbuckle the seat belt by hand before engaging the bolts.

CHILD SEATS

2



Fitting a seat ISOFIX in the rear-left seat means the middle seat cannot be used. The central seat belt will no longer be either accessible or useable.

CHILD SEATS

Installation table

The table below summarises the information shown on the following diagram in order to ensure the regulations in force are respected.

Type of child seat	Weight of the child	Size of seat [fixture]	Front passenger seat (7)		Rear side seats (7)	Rear centre seat (7)
			With airbag deactivated	With airbag activated		
Carrycot fitted across the vehicle Group 0	< 10 kg	L1 [F] L2 [G]	X	X	IL (2)	X
Rear-facing shell seat Groups 0 or 0 +	< 13 kg	R1 [E]	IL (1) (3)	X	IL (4)	X
Rear-facing seat Groups 0+ and 1	< to 13 kg and 9 to 18 kg	R3 [C] R2 [D]	IL (1) (3)	X	IL (4)	X
Forward-facing seat Group 1	9 to 18 kg	F3 [A] F2 [B] F2X [B1]	X	IUF - IL (3)	IUF - IL (5)	X
Booster seat Groups 2 and 3	15 to 25 kg	B2	X	IUF - IL (6)	IUF - IL (5)	X
	22 to 36 kg	B3	X	IUF - IL (6)	IUF - IL (5)	X
Seati-Size	Rear-facing seat		i - U (1) (3)	X	i - U (4)	X
	Forward-facing seat		X	i - UF (3)	i - U (5)	X
	Booster seat		X	i - UF (6)	i - U (5)	X

X = Seat not suitable for fitting child seats of this type.

IUF = Seat allowing a child seat with "Universal or vehicle-specific" approval to be attached using the ISOFIX system on equipped vehicles; check that it can be fitted.

CHILD SEATS

IL = Seat allowing a child seat with "Semi-universal or vehicle-specific" approval to be attached using the ISOFIX system on equipped vehicles; check that it can be fitted.

i-U = Suitable for "Universal" front-facing and rear-facing i-Size restraint devices.

i-UF = Suitable only for "Universal" front-facing and rear-facing i-Size restraint devices.



(1) RISK OF DEATH OR SERIOUS INJURY: before fitting a rear-facing child seat in the front passenger seat, check that the airbag has been deactivated → 112.

(2) A carrycot can be installed across the vehicle and it will take up at least two seats. Position the child with his or her feet nearest the door.

(3) Move the vehicle seat backwards as far as possible and lower it as much as possible, then tilt the seatback slightly (by approximately 25°).

(4) Before installing a rear-facing child seat, move the front seat forwards as far as possible then, once the child seat is installed, move the front seat backwards as far as possible without it touching the child seat.

(5) In all situations, remove the headrest of the rear seat on which the child seat is positioned. This must be done before fitting the child seat (please refer to the "Rear headrests" pages in Section 3 of the vehicle user manual). Move the seat in front of the child forwards, move the seatback forward to avoid contact between the seat and the child's legs.

(6) Raise the seat to the maximum and position it as far back as possible, tilting the seatback slightly (approximately 25°).

The size of the ISOFIX child seat is indicated by a letter:

- F3, F2, F2X [A, B, B1]: for forward-facing seats in group 1 (9 to 18 kg);
- B2: boosters in groups 2 and 3 (15 to 25 kg and 22 to 36 kg);
- R3, R2 [C, D]: rear-facing seats or shell seats in group 0+ (less than 13 kg) or group 1 (9 to 18 kg);
- R1 [E]: rear-facing shell seats in group 0 (less than 10 kg) or 0+ (less than 13 kg);
- L1, L2 [F, G]: carrycots in group 0 (under 10 kg).

CHILD SEATS



(7) Deactivate the "Easy Access Seat" function before installing a child seat on the front passenger seat and/or on the rear seats.

Risk of injury.

CHILD SAFETY: DEACTIVATING, ACTIVATING THE FRONT PASSENGER AIRBAG

Front passenger airbag deactivation



Before installing a child seat on the front passenger seat:

- check that the child seat can be installed on this seat;
- you **must** deactivate the airbag when using a rear-facing child seat.

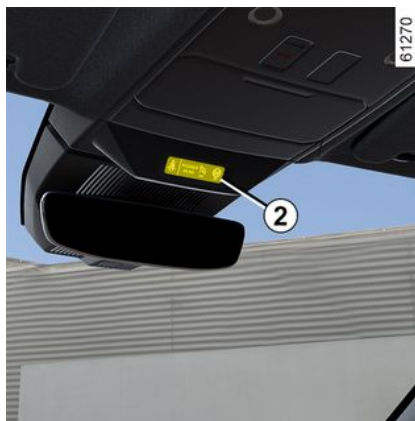

To deactivate the airbag : with the vehicle stationary and the ignition switched off, push and turn the lock 1 to the OFF position.

When the ignition is switched on, you

must check that the  warning light is illuminated on the display 2.

This light remains continuously lit to let you know that you can fit a child seat.



The activation or deactivation of the front passenger airbag must be done **while the vehicle is stationary and the ignition is switched off.**

If it is interfered with when the vehicle is being driven, indicator

lights  and  will come on.

Switch the ignition off then on again to reset the airbag in accordance with the lock position.



DANGER

Since operation of the front passenger airbag is not compatible with the position of a rear-facing child seat, **NEVER** fit a rear-facing child restraint system in a seat protected by a front **AIRBAG that is ACTIVATED.** This could lead to the **CHILD'S DEATH** or **SERIOUSLY INJURY.**

CHILD SAFETY: DEACTIVATING, ACTIVATING THE FRONT PASSENGER AIRBAG

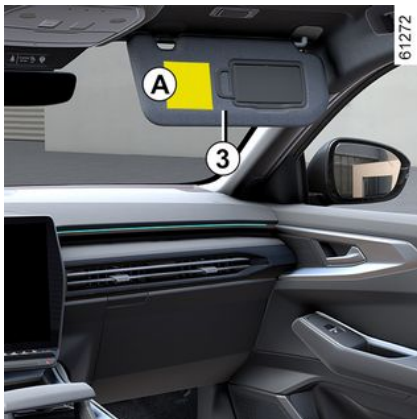

The markings on the dashboard and the labels **A** on each side of the passenger sun visor **3** (see example of la-

bel above) are provided to remind you of these instructions.

Activation of the front passenger airbag





You should reactivate the airbag as soon as you remove the child seat from the front passenger seat to ensure the protection of the front passenger in the event of an impact.



To reactivate the airbag : with the vehicle stationary, and the ignition switched off, push and turn the lock **1 to the ON position.**

When the ignition is switched on, you

must check that the  warning

light is off and that the  warning light appears on the display **2** for around 60 seconds after each start-up.

The front passenger airbag is activated.

Operating faults

It is forbidden to fit a rear-facing child seat to the front passenger seat if the

CHILD SAFETY: DEACTIVATING, ACTIVATING THE FRONT PASSENGER AIRBAG

airbag activation/deactivation system is faulty.

Allowing any other passenger to sit in that seat is not recommended.

Contact your approved Dealer as soon as possible;

2



The passenger airbag may only be activated or deactivated when the **vehicle is stationary with the ignition off.**

If it is interfered with when the vehicle is being driven, indicator

lights  and  will come on.

Switch the ignition off then on again to reset the airbag in accordance with the lock position.

DRIVING POSITION

Driving position: left-hand drive

2

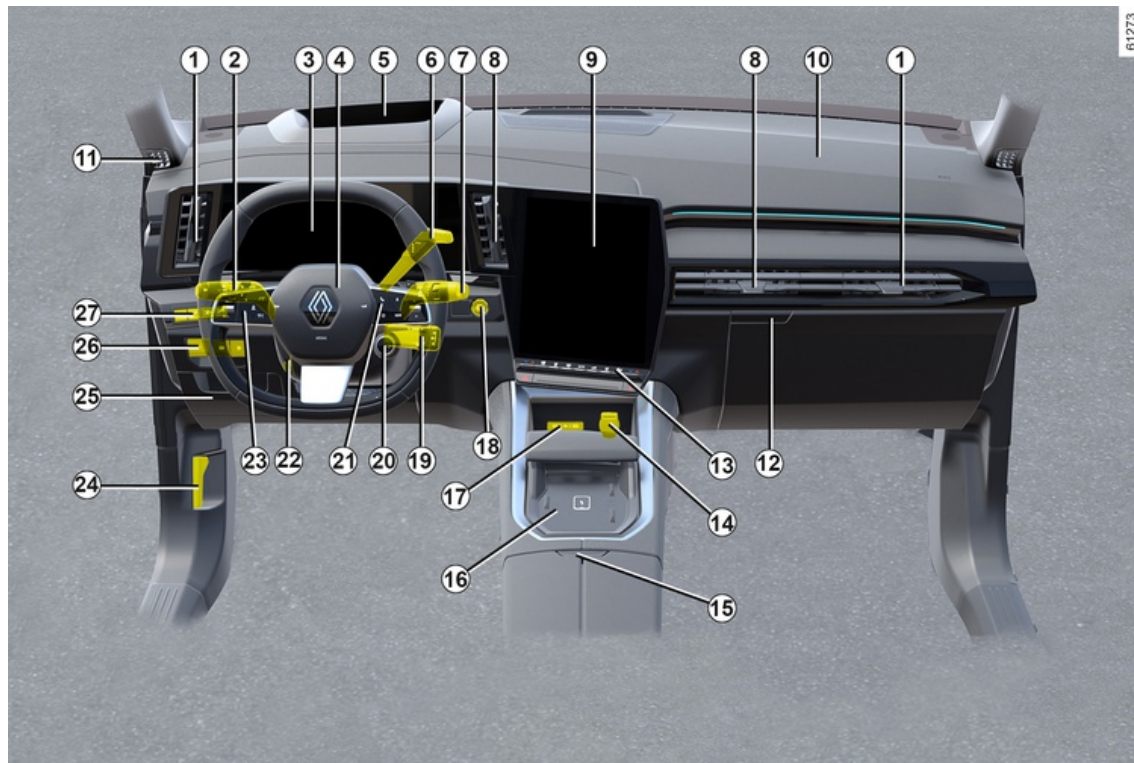

61273

DRIVING POSITION

The fittings described below DEPEND ON THE VEHICLE VERSION AND COUNTRY.

1. Side air vents.

2. Stalk for:

- direction indicator lights;
- exterior lights;
- rear fog lights.

3. Instrument panel.

4. Driver airbag and horn location.

5. Head-up display.

6. Gear lever (automatic gearbox, depending on the vehicle).

7. Steering column stalk for wind-screen and rear screen wash/wiper.

8. Centre air vents.

9. Multimedia screen.

10. Passenger airbag location.

11. Demister outlet.

12. Glovebox

13. Controls for:

- front heated seats;
- heating or air conditioning;
- hazard warning lights;
- electric door locking.

14. Accessories socket.

15. Centre armrest/storage compartment.

16. Charging zone/telephone storage

17. USB-C sockets.

18. Engine start/stop button.

19. Radio remote control.

20. Control MULTI-SENSE.

21. Controls for:

- trip computer information readout;
- remote radio and navigation system.

22. Control for adjusting steering wheel height and reach.

23. Main switch and controls for the speed limiter/adaptive cruise control Stop and Go.

24. Bonnet release control.

25. Fixed storage compartment and fuse box.

26. Controls for:

- activating/deactivating the electronic parking brake;
- activating/deactivating the AUTOHOLD function;
- opening the fuel filler flap;
- ...

27. Controls for:

- lighting dimmer for control instruments;
- activation/deactivation of the Lane Keep Assist function (lane departure warning, lane departure prevention, lane centring);
- luggage compartment opening control;
- ...

DRIVING POSITION

Driver's position, right-hand drive

2

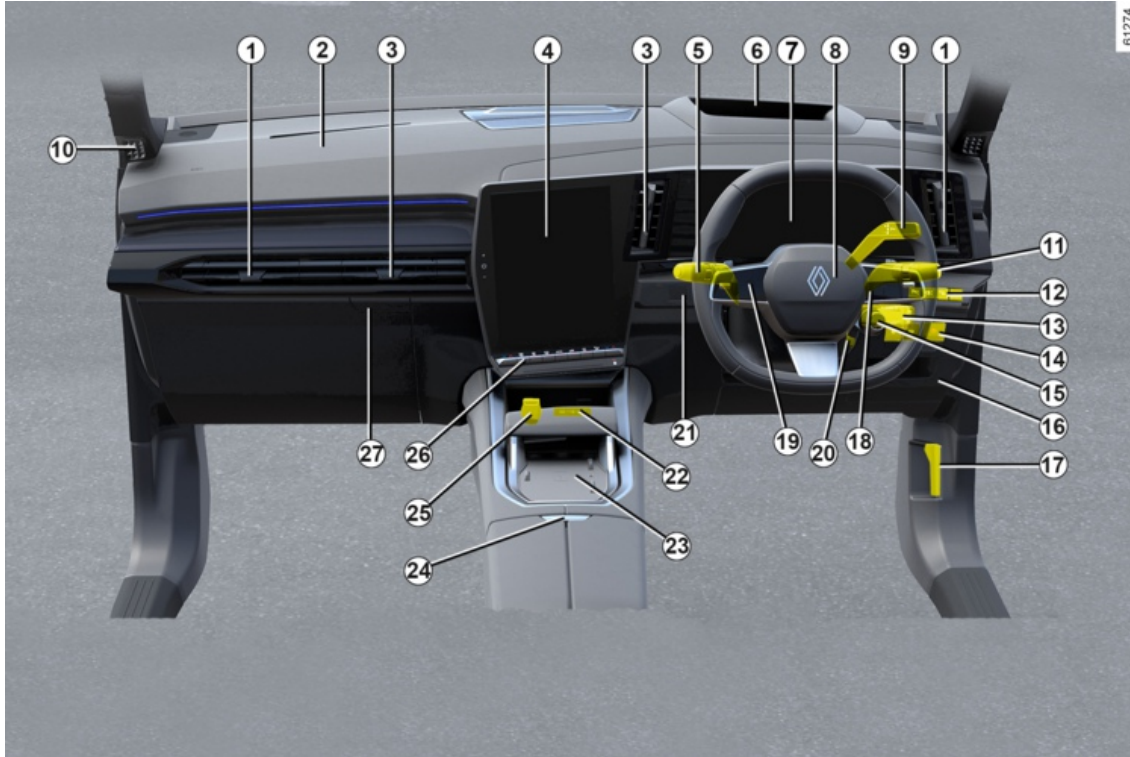

DRIVING POSITION

The fittings described below DEPEND ON THE VEHICLE VERSION AND COUNTRY.

1. Side air vents.
2. Passenger airbag location.
3. Centre air vents.
4. Multimedia screen.
5. Stalk for:
 - direction indicator lights;
 - exterior lights;
 - rear fog lights.
6. Head-up display.
7. Instrument panel.
8. Driver airbag and horn location.
9. Gear lever (automatic gearbox).
10. Demister outlet.
11. Steering column stalk for wind-screen and rear screen wash/wiper.
12. Controls for:
 - lighting dimmer for control instruments;
 - activation/deactivation of the Lane Keep Assist function (lane departure warning, lane departure prevention, lane centring);
 - luggage compartment opening control;
 - ...

13. Radio remote control.
14. Controls for:
 - activating/deactivating the electronic parking brake;
 - activating/deactivating the AUTO-HOLD function.
 - opening the fuel filler flap;
 - ...

15. Control MULTI-SENSE.
16. Fixed storage compartment.
17. Bonnet release control.
18. Controls for:
 - trip computer information readout;
 - remote radio and navigation system.

19. Main switch and controls for cruise control/speed limiter and Stop and Go adaptive cruise control.

20. Control for adjusting steering wheel height and reach.

21. Engine start/stop button.

22. USB-C sockets.

23. Charging zone/telephone storage

24. Centre armrest/storage compartment.

25. Accessories socket.

26. Controls for:

- front heated seats;
- heating or air conditioning;
- hazard warning lights;
- door central locking;
- ...

27. Glove box and fuse box.

TRIP COMPUTER

General information

2 Trip computer and warning system

A



Depending on the vehicle, this includes the following functions:

- trip settings;
- information messages;
- operating fault messages (related to

the  warning light);

- warning messages (connected to the

 warning light).

Repeatedly press upwards/downwards on the switch **1** to browse between these functions.

From the instrument panel A:

a) trip settings:

- consumption since the last reset and current fuel consumption;
- distance travelled since the last reset;

b) service interval;

c) trip log, operating faults and information messages.

Resetting the trip mileage recorder and journey parameters (reset button)



With one of the trip parameters selected as the display, press and hold the switch **1** until the display resets to zero.

Automatic resetting of the journey parameters

Resetting occurs automatically when the maximum value of any of the parameters is exceeded.

Interpreting some of the values displayed after resetting

The values showing average fuel consumption, range and average speed will become more stable and reliable the further you travel after pressing the reset button.

For the first few miles after pressing the reset key you will notice that the range increases as you travel. This range takes into account the average fuel consumption since the last time the reset button was pressed. However, average consumption can decrease when:

- the vehicle stops accelerating;
- the engine reaches its operating temperature (if the engine was cold when the reset key was pressed);
- when driving from an urban area onto the open road.

TRIP COMPUTER



Some on-board computer information appears on the navigation system display.



The trip settings mileage recorder is reset simultaneously in the on-board computer and the navigation system.

TRIP COMPUTER

Journey settings

2

The display of information shown below **DEPENDS ON THE VEHICLE EQUIPMENT AND COUNTRY.**

Examples of selections	Interpreting the display selected
No stored message	a) Trip log. Successive display: <ul style="list-style-type: none">– information messages (passenger airbag OFF etc.);– operating fault messages (check the injection system, etc.).
 7.4 L/100	b) Current fuel consumption. This value is displayed after a speed of approximately 19 mph (30 km/h) is reached.
 5.8 L/100	
 112,4 km	

TRIP COMPUTER

<p>Examples of selections</p>	
<p>On-board computer with mileage-before-service message</p>	<p>Interpreting the display selected</p>
<p>Service in 18,641 miles (30,000 km)/12 months</p>	<p>e) Range before service and oil change. Service distance With the ignition on and the engine not running, access the "Mileage before service" information. When the distance or time value approaches its limit, there are several possible scenarios:</p>
<p>Service due in less than 186 miles (300 km) or 24 days</p>	<p>– mileage remaining less than 932 miles (1,500 km) or one month: the "Service due in" message is displayed accompanied by the nearest limit (distance or time); – range equal to 0 miles (0 km) or date of service reached: the message "Ser-</p>
<p>Service vehicle</p>	<p>vice required" is displayed accompanied by the warning light  . The vehicle requires a service as soon as possible.</p>
<p>Resetting: to reset the mileage before the next service, press and hold the OK button for approximately 10 seconds until the display shows the mileage before service permanently.</p> <p>Note: if a service is performed without changing the engine oil, only the mileage before the next service should be reset. In the event of an oil change, both the distance before the next service and the next oil change should be reset.</p>	
<p>Oil change in 18,641 miles (30,000 km)/24 months</p>	<p>f) Mileage before oil change With the ignition on and the engine not running, access the "Mileage before service" information to display the mileage before the next oil change.</p>
<p>Depending on the vehicle, the mileage before an oil change varies according to the driving style (frequent driving at low speed, door-to-door journeys, extensive use at idling speed, towing a trailer, etc.). The distance remaining until the next oil change can therefore decrease more quickly in some cases than the actual distance travelled.</p> <p>Reset: to reset the distance before the next service, press and hold button OK for approximately 10 seconds until the display shows the mileage before oil change permanently.</p> <p>Note: if a service is performed without changing the engine oil, only the mileage before the next service should be reset. In the event of an oil change, both the distance before the next service and the next oil change should be reset.</p>	

TRIP COMPUTER

Information messages

These can help in the vehicle starting phase, or give information about a selection or a driving status.

Examples of information messages are given in the following pages.

Examples of messages	Interpreting the display selected
"Turn steering wheel + START"	Turn the steering wheel slightly whilst pressing the vehicle start button to unlock the steering column.
"Checking control functions"	Displayed with the ignition on when the vehicle is running self-diagnostics.

TRIP COMPUTER

Operating fault messages

These appear with the  warning light to inform you that you should drive very carefully to an approved dealer as soon as possible. If you fail to follow this recommendation, you risk damaging your vehicle.

They disappear when the display selection key is pressed or after several seconds and are stored in the computer log. The

 warning light stays on. Examples of operating fault messages are given in the following pages.

Examples of messages	Interpreting the display selected
"Check vehicle"	Indicates a fault in one of the pedal sensors, battery management system or oil level sensor.
"Check airbag"	Indicates a fault in the restraint system in addition to the seat belts. In the event of an accident, it is possible that they may not be triggered.
"Check Post-collision"	Indicates a problem with the multi-collision braking.
"Check emission control"	– Indicates a fault in the vehicle's particle filter system. – Indicates a fault in the emissions reduction system when it is accompanied by the  warning light.
"Check electrical system"	Indicates a fault in the traction system.

TRIP COMPUTER

Warning messages

2

These appear with the **STOP** warning light and require you to stop immediately, for your own safety, as soon as traffic conditions allow. Stop your engine and do not restart it. Call an approved Dealer.

Some examples of warning messages are given below. **Note:** the messages appear on the display either individually or alternately (when there are several messages to be displayed), and may be accompanied by a warning light and/or a beep.

Examples of messages	Interpreting the display selected
"Risk of engine failure"	Indicates an injection fault, the vehicle's engine has overheated or there is a serious engine fault.
"Braking system fault"	Indicates a fault in the braking system.
"Puncture"	Indicates that at least one wheel is punctured or severely underinflated.
"Steering fault"	Indicates a problem with the steering.
"Electrical fault"	Indicates a fault in the vehicle battery charging circuit (alternator, etc.) or a fault in the electrical system.
"Electric engine fault"	Indicates that the vehicle is losing power.

TRIP COMPUTER

Displays and indicators

Instrument panel



lights up when the driver's door is opened. In some cases, the appearance of a warning light is accompanied by a message.

Depending on the vehicle, you can customise your instrument panel **A** with the content and colours of your choice.

Selection of views

Depending on the vehicle, several views are available on the instrument panel. To select a view press as many times as necessary on the control **1** to

scroll through the various views on the instrument panel **A** until you reach the desired view.

All of the available views display the following essential information on the instrument panel:

- speedometer;
- the information on the activated driving aids;
- information area.

The "Driving aids" view displays the essential information on the instrument panel with that of the active driving aids in full screen.

The "Classic" view displays the essential information on the instrument panel and, depending on the vehicle, the power meter.

The "Navigation" view displays the essential information and the road map duplicated from the multimedia system on the entire instrument panel.

Realistic view B
(depending on the vehicle)

617292



View **B** displays the essential information on the instrument panel, along with your vehicle and its environment (lanes, surrounding vehicles moving in the same direction, etc.).

Note: the system only recognises vehicles in the car, lorry and motorbike categories.

The "Minimal" view displays only the essential information on the dashboard.

2

TRIP COMPUTER

Information display

2

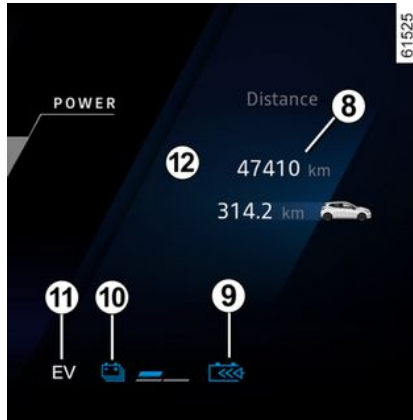
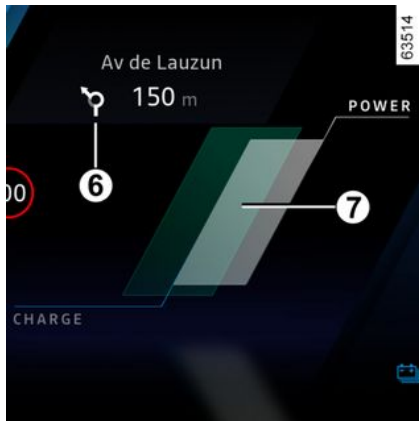
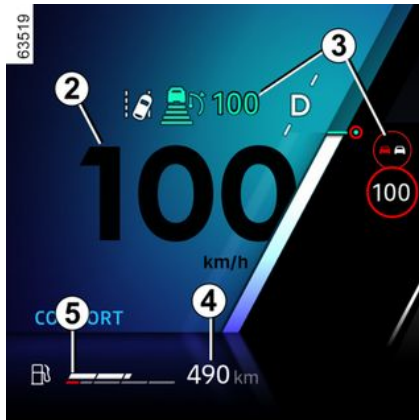

Speedometer 2

Information on driving aids 3

Estimated range with remaining fuel 4

Fuel gauge 5

If the level is at the minimum, the integrated  warning light appears in orange, accompanied by a beep. Fill up as soon as possible.

Information on navigation in progress 6

Power meter 7

The power meter gives the driver a real-time view of the vehicle's energy consumption → 180.

Total mileage recorder 8

Regenerative braking level warning light 9 → 24 → 29

Traction battery charging level 10

Electric operating mode warning light 11

It is displayed when only the traction battery is powering movement of the vehicle.

Information area 12



Depending on the vehicle, use the control 13 to browse and select the various on the instrument panel:

- trip computer information (mileage recorder, warning messages, etc.);
- multimedia information (compass, audio source currently playing, etc.);
- ...

TRIP COMPUTER

Head-up display 18



The display details driving and navigation information from the instrument panel and the multimedia screen. The information is projected onto the windscreen.

If fitted to the vehicle, this is activated when the engine is started and is deactivated when the engine is switched off.

Refer to the multimedia instructions to access the head-up display settings.

Adjusting the display information height

Depending on your driving position, you can raise or lower the information

on the display. You can also slightly rotate the projected image.

Adjusting the display brightness

The brightness varies automatically according to the light level outside the vehicle. Once the lights are switched on, it is possible to manually adjust the brightness.



For safety reasons, carry out any adjustments while the vehicle is stationary.



Do not use solvents, detergents or an abrasive cloth to clean the protective film.

Only use a microfibre wipe.



The visibility of information may be affected by:

- the seat position;
- the presence of an object placed on the dashboard opening;
- the use of polarised spectacle lenses;
- extreme weather conditions (rain, snow, very strong sunlight, etc.).



Refer to the information displayed on the instrument panel in case of conflicting information between the panel and the head-up display/multimedia screen.

TRIP COMPUTER

Instrument panel in miles



(option to switch to km/h)

With the vehicle stationary and the engine on, from the multimedia screen **19** select the "Vehicle" world, press the "Settings" menu followed by "System", "Units" then "Speed".

Choose between km/h or mph.

The speedometer and some of the distance information displayed on the instrument panel are converted.

To return to the previous mode, repeat the same operation.

Note: once the battery is switched off, the trip computer automatically returns to the original unit of measurement.

Please refer to the multimedia instructions for more information.



To use certain driving aids, it is necessary to change the unit of measurement on the instrument panel in order to obtain the correct information when driving in a country where the speed units differ from those set as default on your vehicle.



For safety reasons, carry out any adjustments while the vehicle is stationary.

Vehicle settings personalisation menu

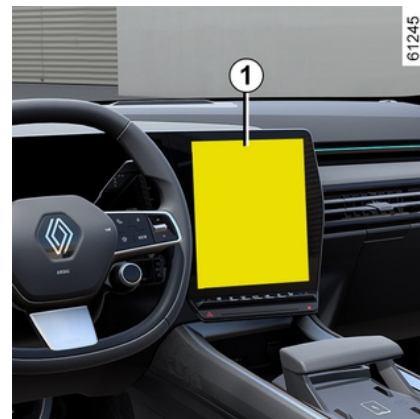

Depending on the vehicle equipment, this function allows you to activate/deactivate and adjust some of the vehicle's functions.

Accessing the settings menu

With the vehicle stationary and the engine on, from the multimedia screen **1** select the "Vehicle" world, press the "Vehicle" menu then the "Exterior" tab to access the various settings.

TRIP COMPUTER

Adjusting the settings

Select a tab then the function to be modified (the display depends on the vehicle equipment and country):

a) "Access":

- "Automatic door locking while driving";
- "Locking/unlocking in hands-free mode";
- "Access and starting by phone";
- ...

b) "Welcome":

- "Exterior lighting animation";
- "Door opening welcome sound";
- "Automatic fold-out of the door mirrors";
- "Automatic courtesy light";
- ...

c) "Lighting":

- "Adaptive lighting";
- "Choice of driving side";
- ...

d) "Wipers":

- "Rear screen wiping in reverse";
- "Automatic front wiping";
- ...

Depending on the function, select:

- "ON" or "OFF" to activate or deactivate it;

or

– a setting for the time the lights are switched on (e.g. for the "Follow-me-home lighting" function).

Please refer to the multimedia instructions for further information.



For safety reasons, carry out any adjustments while the vehicle is stationary.

"Favourites" function



Depending on the vehicle, by pressing the steering wheel control **2** you can activate the following functions accord-

ing to the stored user settings that you have previously defined:

- heated seats;
- heated steering wheel;
- setting selection (access, welcome, lighting, wiper, etc.);
- "Hands-free parking" function;
- ECO mode;
- 360° camera;
- HDC;
- ...

For more information on programming this function, please refer to the multimedia instructions.



For safety reasons, carry out any adjustments while the vehicle is stationary.

Driving position

(depending on the vehicle)

TRIP COMPUTER

2



61244

- by changing the user profile;
- by pressing the "Recall" button for the driver's seat;
- by pressing the buttons **6** for the passenger seat.

The forward driving position includes the settings for:

- the seat base;
- the seatback;
- the door mirrors.

Storing your driving position

With the vehicle stationary and the engine on, from the multimedia screen 1 select the "Vehicle" world then the "Seats" menu.

- Adjust the driver's and/or passenger's → **74** seat;
- adjust the door mirrors → **141**.

Then press "Save" to store.

Refer to the multimedia instructions for information on accessing the stored driving position.

Recalling the driving position

To access the stored driving position, select "Recall" on the multimedia screen.

For more information on storing the driving position, please refer to the multimedia instructions.

Note: the driving position recall is interrupted if a seat adjustment button is pressed.

When the vehicle is started by pressing and holding the engine start/stop button, the driving position is adjusted according to the last stored profile.



On vehicles that are equipped with this function, you can store and recall the driving position using the facial recognition system → **72**.



When recalling a position (memorisation, changing profile), make sure that no one is near the moving parts (in particular, in the rear seats). For safety reasons, carry out any adjustments when the vehicle is stationary.



61246

From the multimedia system, you can store and recall the driving position by pressing buttons **3**, **4** and **5** (→ **74**):

TRIP COMPUTER

Clock and outdoor temperature

Clock



The time and outdoor temperature are displayed on the multimedia screen **1**. Please refer to the multimedia instructions for further information.

Exterior temperature indicator

Special feature:

When the outside temperature is between -3°C and $+3^{\circ}\text{C}$, the $^{\circ}\text{C}$ figures flash (this indicates a risk of ice formation).



If the power supply is cut (battery disconnected, supply wire cut, etc.), the clock must be reset. We recommend that you do not adjust these settings while driving.



Exterior temperature indicator

As ice formation is related to climatic exposure, local air humidity and temperature, the external temperature alone is not sufficient to detect ice.

WARNING LIGHTS

The display of information shown below **DEPENDS ON THE VEHICLE EQUIPMENT AND COUNTRY.**



Instrument panel A: this lights up when the driver's door is opened.

To adjust the brightness, see the multimedia user manual.

In some cases, the appearance of a warning light is accompanied by a message on the instrument panel.



Warning light  means you should drive **very carefully to an authorised dealer as soon as possible.** If you fail to follow this recommendation, you risk damaging your vehicle.



If the **STOP** warning light appears, for your safety you must stop the vehicle as soon as traffic conditions allow. Switch off the engine and do not restart it. Call an approved dealer.



If no lights or sounds are apparent, this indicates a fault in the instrument panel. This indicates that it is essential to stop immediately (as soon as traffic conditions allow). Ensure that the vehicle is correctly immobilised and contact an approved Dealer.



Side light tell-tale light



Main beam headlight tell-tale light



Dipped beam headlight tell-tale light



Rear fog lights tell-tale



Automatic main beam headlight warning light → 143



Left-hand direction indicator tell-tale light



Right-hand direction indicator tell-tale light

WARNING LIGHTS



Bad weather warning light

→ 143



Warning light to indicate a fault with the headlights Adaptive vision



Electronic parking brake applied warning light → 171



"AUTOHOLD" system warning light → 174



Automatic wiping function warning light



Tell-tale light for airbag

It lights up when the ignition or the engine is switched on and goes off after a few seconds.

If it does not light up when the ignition is switched on, or if it lights up when the engine is running, this indicates a fault in the system.

Contact your approved Dealer as soon as possible;



Urgent stop warning light

This lights up when the ignition or engine is switched on and goes out as soon as the engine is running. It comes on with other warning lights

and/or messages, and is accompanied by a beep.

For your own safety, it requires you to stop immediately, as soon as traffic conditions allow. Switch off the engine and do not restart it.

Call an approved dealer.



Brake circuit fault warning light

It lights up when the ignition or the engine is switched on and goes off after a few seconds.

If it comes on during braking and is ac-

companied by the **STOP** warning light and a beep, it indicates that the fluid level in the circuit is low or that there is a braking system fault. Stop as soon as traffic conditions allow and consult an approved dealer.



Battery charge warning light

It lights up when the ignition or the engine is switched on and goes off after a few seconds.

If it comes on on the road, accompa-

nied by the **STOP** warning light and a beep, this indicates an overload or discharge in the electrical circuit. Stop as soon as traffic conditions allow and consult an approved dealer.



Oil pressure warning light

It lights up when the ignition or the engine is switched on and goes off after a few seconds.

If it comes on on the road, accompa-

nied by the **STOP** warning light and a beep, stop immediately and cut the ignition.

Check the oil level. If the level is normal, the warning light is related to something else.

Call an approved dealer.



Variable power assisted steering warning light

It lights up when the ignition or the engine is switched on and goes off after a few seconds.

If it comes on while driving, alongside

the warning light **STOP**, this means there is a system fault.

Call an approved dealer.



Warning light

This lights up when the ignition or engine is switched on and goes out as soon as the engine is running. It can light up in conjunction with other warning lights and/or messages on the instrument panel. It means you should **drive very care- fully** to an approved

WARNING LIGHTS

Dealer as soon as possible. If you fail to follow this recommendation, you risk damaging your vehicle.



Warning light for the electronic stability program (ESC) and traction control system

It lights up when the ignition or the engine is switched on and goes off after a few seconds.

The → 187 warning light may appear for several reasons.



Warning light for non-availability of the electronic stability program (ESC) and traction control system



Door status warning light



Anti-lock braking warning light

It lights up when the ignition or the engine is switched on and goes off after a few seconds.

If it comes on when you are driving, it indicates a fault on the antilock braking system.

Braking will then be as normal, without the ABS. Contact your approved Dealer straight away.



Particle filter system warning light → 169



Tyre under-inflation warning light

This lights up when the ignition is switched on or when the engine starts, then disappears after a few seconds → 183.



Toxic fume filter system warning light

On vehicles that are equipped, this light comes on when the engine is started and, depending on the vehicle, when the ignition is switched off while the engine is in the standby phase, before going out.

- If it lights up continuously, contact an approved dealer as soon as possible;
- If it flashes, reduce the engine speed until the light stops flashing. Contact an approved dealer as soon as possible → 177.



Low fuel level warning light

It lights up orange when the ignition or the engine is switched on and goes off after a few seconds.

If the light becomes orange while driving and a beep sounds, fill up with fuel as soon as possible. There is only approximately 31 miles (50 km) worth of fuel left.



Coolant temperature warning light

This lights up when you switch on the ignition or when the engine starts. If it turns red, stop and let the engine idle for a minute or two.

If the temperature does not decrease, switch off the engine. Let the engine cool down before checking the coolant.

Call an approved dealer.



Speed limiter warning light → 248



Stop and Go adaptive cruise control warning light → 252



Brake pedal warning light

This lights up when the brake pedal should be pressed → 163.



Electronic parking brake fault light → 277



Overspeed warning light → 127



Lane centring system warning light → 232

WARNING LIGHTS



Lane departure prevention system warning light → 196



Warning light of the "Active emergency braking" function → 220



Warning light to indicate a fault or unavailability of "Active emergency braking" function → 220



Hands off steering wheel detection warning light → 196



Hill Descent Control (HDC) warning light → 187



Electrotechnical system warning light

It appears when the temperature of the electrical assembly is too high. Stop the vehicle without switching off the ignition. The temperature should lower and the warning light should disappear. If this is not the case, please consult an Authorised Dealer.

The warning light can be accompanied by a drop in vehicle performance.



Secondary 12 V battery charge warning light

If it comes on, accompanied by the

warning light **STOP** and a beep, this means that the electrical circuit is overcharged or discharged → 339.



Pedestrian horn fault warning light



Traction battery fault warning light

If it appears, accompanied by the



warning light, this indicates a fault related to the operation of the traction battery. Contact your approved Dealer straight away.



Traction battery gauge warning light

This appears in yellow when the traction battery charge level has reached the reserve level → 29 → 24.



EV Electric operating mode warning light

It is displayed when only the electric motor and traction battery are powering the movement of the vehicle → 29 → 24.



Charging cord plugged in warning light

This lights up when the charging lead is plugged into the vehicle → 29.



Electric motor fault warning light

When it comes on, this indicates a fault with the electrotechnical system linked to the electric motor. Contact your approved Dealer straight away.



For your own safety, the



warning light requires you to stop immediately, as soon as traffic conditions allow. Switch off the engine and do not restart it. Call an approved dealer.

WARNING LIGHTS

On display *B*

2

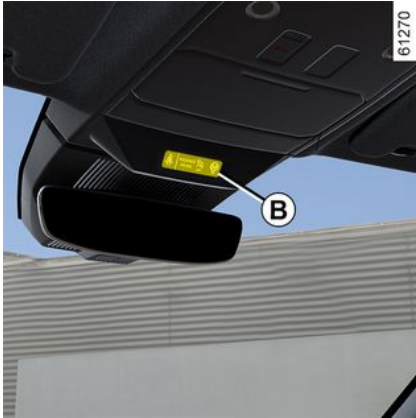

Passenger **Airbag ON** → 113



Passenger **Airbag OFF** → 112



Seat belt reminder warning light → 80

STEERING

Steering wheel

Adjusting the steering wheel height and depth



Lower the lever **1** and set the steering wheel to the required position.

Then, raise the lever fully, beyond the point of resistance to lock the steering wheel.

Make sure that the steering wheel is correctly locked.



For safety reasons, only adjust the steering wheel when the vehicle is stationary.

Steering wheel heating

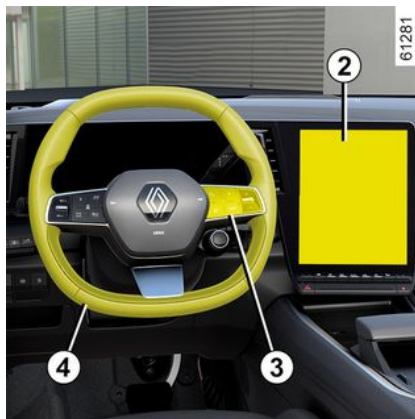

(depending on the vehicle)

This function heats the steering wheel **4**.

Operating principle

When the temperature is reached, the function regulates the temperature of the heated areas for approximately 30 minutes and then switches off automatically.

Activating/deactivating the function

With the ignition on, press the button **5** on the multimedia screen **2**.

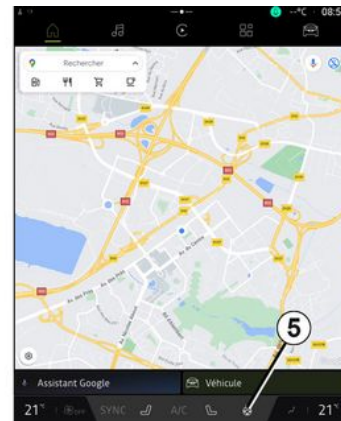

Deactivating the function

– Automatically:

The function switches off automatically after the regulation phase of approximately 30 minutes.

– Manually:

To deactivate the function during the regulation phase, press the button **5** on the multimedia screen **2**.

Note: the function can also be accessed using the "Favourites" button **3** on the steering wheel **4**.

STEERING

Power-assisted steering

Never drive with an inadequately charged battery.

Variable power assisted steering

The variable power-assisted steering system is equipped with an electronic control system which alters the level of assistance to suit the vehicle speed.

Steering is made easier during parking manoeuvres (for added comfort) while the force needed to steer increases progressively as the speed rises (for enhanced safety at high speeds).

Special case

Depending on the vehicle, in the event of a battery fault (disconnected, discharged battery, etc.), a reset of the power-assisted steering must be carried out. To do this:

- the vehicle stationary and on flat ground;
- with only the driver in the vehicle,

start the engine: the  warning light and/or, depending on the vehicle, the "Turn steering wheel fully right and left" message is displayed on the instrument panel;

- turn the steering wheel fully to the left, then to the right. When the engine next starts, the indicator and/or, de-

pending on vehicle, the message will switch off.

Note: the power-assisted steering depends on the driving mode selected in the "MULTI-SENSE" menu → 301.



Never leave the steering wheel on full lock when the vehicle is stationary.



With the engine switched off, or if there is a system fault, it is still possible to turn the steering wheel. The force required will be greater.



Never switch off the ignition when travelling downhill, and avoid doing so in normal driving (power steering and brake servo will not function).

REAR VIEW

Rear view mirrors

Exterior rear view mirrors



Adjustment

When you select the door mirror using the switch **2**, the warning light built into the switch will appear. Then use the button **1** to adjust it to the desired position.

Heated rear view mirrors

Mirror de-icing is carried out at the same time as rear screen de-icing → **307**.



For safety reasons, carry out any adjustments while the vehicle is stationary.

Rear view mirrors which tilt in reverse gear

On vehicles equipped with this function, you can enter a specific setting for the door mirrors when reversing and store the position.

With the vehicle stationary and the reverse gear engaged, select the door mirror using the switch **2** (the switch indicator light comes on), then use the button **1** to adjust it to the desired position.

It is possible to move from the reverse gear to a forward gear:

- approximately nine seconds when switching to **N** or **D** position with the speed below 6 mph (10 km/h);
- with the forward gear engaged when the speed is greater than 6 mph (10 km/h);



Objects observed in the rear view mirror glass are actually closer than they appear. For your safety, take this into account in order to correctly assess the distance before any manoeuvre.

– when the engine is stopped.

Driver's position: storage

You can store the door mirror position for forward driving in relation to the driving position stored for the driver's seat → **131**.

Electrical folding mirrors

The door mirrors will fold-out automatically when the vehicle is unlocked. The door mirrors fold in when the vehicle is locked.

You can deactivate/activate automatic folding of the door mirrors → **130**.

You can force folding by pressing the switch **3**. In this situation, the door mirrors will remain folded until the **3** button is pressed again, regardless of automatic folding.

Special case

REAR VIEW

When the rear view mirror has been manually deployed or folded back, it is possible to reset it to a usage position.

To do this, press the switch **3**. A mechanical tapping noise can be heard from the door mirror.

If a tapping noise cannot be heard, press the switch **3** again until the tapping noise can be heard from the door mirror.

Interior rear view mirror

Rear view mirror with lever **4**



When driving at night, to avoid being dazzled by the headlights of the vehicle behind, shift the small lever **4** located behind the rear view mirror.



For safety reasons, carry out any adjustments while the vehicle is stationary.

Rear view mirror without lever **4**



(depending on the vehicle)

The rear view mirror **5** automatically darkens when you are being followed by a vehicle whose headlights are shining on your vehicle or in the case of bright exterior light.



Objects observed in the rear view mirror glass are actually closer than they appear. For your safety, take this into account in order to correctly assess the distance before any manoeuvre.

LIGHTING AND SIGNALS

Exterior lighting and signals

Daytime running lights



61290

Rotate the ring **3** until the "AUTO" symbol is opposite the mark **2**.

The daytime running lights come on automatically (without any action on the stalk **1**) when the engine is started and they switch off when the engine is switched off.

Side lights



61291



Turn the ring **3** until the symbol is opposite the mark **2**. This indicator light on the instrument panel comes on.

Note: depending on the vehicle, the side lights can only be activated manually when the parking brake is applied or, depending on the vehicle, when the gear lever is in the **P** position.

Otherwise, the "Unavailable position lights" message is displayed on the instrument panel to inform you that it is not possible to activate the side lights.

Dipped beam headlights



Manual operation

Turn the ring **3** until the symbol is opposite the mark **2**. This indicator light on the instrument panel comes on.



Before driving at night, check that the electrical equipment is operating correctly and adjust the headlight beams (if your vehicle is not carrying its normal load). As a general precaution, check that the lights are not obscured (by dirt, mud, snow or objects being transported).

Automatic operation

Rotate the ring **3** until the "AUTO" symbol is opposite the mark **2**: with the engine on, the dipped-beam headlights switch on or off automatically according to the exterior light level without any action required on the stalk **1**. Depending on the vehicle, the dipped beam headlights will appear automati-

LIGHTING AND SIGNALS

cally after several sweeps of the windscreen wiper blades.

2 Adaptive front lighting system

(depending on the vehicle)

This function automatically adjusts the width and range of the dipped beam headlights according to the speed and weather conditions.

Rotate the ring **3** until the "AUTO" symbol is opposite the mark **2**: with the engine on.

This function can be deactivated, refer to the multimedia instructions.

Operating faults

If the "Check automatic lighting" message appears on the instrument panel, the system is deactivated. Consult an approved dealer.

Main beam headlights



61292

 With the engine on and the dipped beam headlights on, push the stalk **1** (movement **A**).

This indicator light on the instrument panel comes on.

To return to the dipped beam headlights position, push the stalk **1** again.

Automatic main beam headlights

 Depending on the vehicle, this system switches the main beam headlights on and off automatically.

It uses a camera located behind the interior rear view mirror to detect vehi-

cles that are being followed and those coming in the opposite direction.

Note: at night, in urban areas with street lighting, the automatic main beam headlights automatically switch off.

The main beam headlights come on automatically if:

- the exterior light level is low;
- no other vehicle or lighting is detected;
- the vehicle speed is above approximately 25 mph (40 km/h).

If any of the above conditions are not fulfilled, the system switches to dipped beam headlights.

Note: make sure that the windscreen is not obscured (dirt, mud, snow, condensation, etc.).

LIGHTING AND SIGNALS

Activation/deactivation

61290





To activate the automatic main beam headlights

Rotate the ring **3** until the "AUTO" symbol is opposite the mark **2**, then press the switch **6**.

The indicator light  on the instrument panel lights up if the dipped beam headlights are on.

To deactivate the automatic main beam headlights:

Press the switch **6**: the  warning light disappears from the instrument panel.

Note: when you push the stalk **1**, the automatic main beam headlights function is deactivated, the  warning light disappears from the instrument panel and the vehicle activates the main beam headlights.

tion is deactivated, the  warning light disappears from the instrument panel and the vehicle activates the main beam headlights.

Operating faults

If the "Check automatic lighting" message appears on the instrument panel, the system is deactivated.

Consult an approved dealer.



The system may encounter difficulties under certain conditions, including:

- extreme weather conditions (rain, snow, fog, etc.);
- obstruction in front of the windscreen or camera;
- when a following or oncoming vehicle has weak or hidden lighting;
- incorrect settings for the front headlights;
- reflecting systems;
- ...



Using a portable navigation system at night in the windscreen area below the camera may disturb the operation of the "automatic main beam headlights" system (risk of reflection on the windscreen).



The "automatic main beam headlights" system should under no circumstances be used to replace the driver's attention and responsibility with regard to vehicle lighting and adapting to light, visibility and traffic conditions.

2

LIGHTING AND SIGNALS

Adaptive main beam headlights



Depending on the vehicle, the adaptive high beam headlights are divided into several independent vertical segments. This function uses a camera **7** located behind the interior rear view mirror to detect vehicles that are in front as well as vehicles moving in the opposite direction.

Note: make sure the windscreen is not obscured (dirt, mud, snow, condensation, etc.).

When a vehicle is detected, the segments illuminating this area automatically switch off so as not to dazzle it.

Under certain conditions, the brightness of the adaptive main beam head-

lights will be modified to optimise lighting:

- when approaching reflective signs, the lighting power will be locally reduced in order to limit dazzling;
- when on a motorway, the beam will be reduced in order to minimise the annoyance to road users moving in the opposite direction.

Switching on

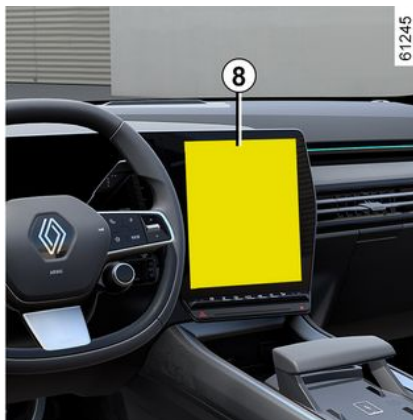

From the multimedia screen **8**, access the "Vehicle" world and press the "Vehicle" menu, then "Exterior" and "Lighting".

Activate or deactivate "Adaptive lighting".

Please refer to the multimedia instructions for further information.

The main beam headlights come on automatically if:

- the exterior light level is low;
- the vehicle speed is higher than the threshold.

If any of the above conditions are not fulfilled, the system switches to dipped beam headlights.

Note: at night, in urban areas with street lighting, the adaptive main beam headlights automatically switch off.



The "Adaptive main beam headlights" system should under no circumstances substitute the driver's attention and responsibility with regard to vehicle lighting and adapting to light, visibility and traffic conditions.

LIGHTING AND SIGNALS

Activation/deactivation



61290

To activate the adaptive main beam headlights

Rotate the ring **3** until the "AUTO" symbol is opposite the mark **2**, then press the switch **6**.

The indicator light  on the instrument panel lights up if the dipped beam headlights are on.

To deactivate the adaptive main beam headlights:

Press the switch **6**: the  warning light disappears from the instrument panel.

 The system may encounter difficulties under certain conditions, including:

- extreme weather conditions (rain, snow, fog, etc.);
- obstruction in front of the wind-screen or camera;
- when a following or oncoming vehicle has weak or hidden lighting;
- incorrect settings for the front headlights;
- reflecting systems;
- ...

Special feature

The adaptive lighting of the main beam headlights is suited to the (My Sense/ECO/Comfort/Sport) driving mode selected. The speed thresholds for activation and deactivation are different:

- In My Sense, ECO or Comfort mode, the adaptive main beam headlights will switch on when the vehicle speed is above approximately 25 mph (40 km/h) and switch off when the vehicle speed is below approximately 12 mph (20 km/h).

The strength of the main beam headlights adapts to the speed of the vehicle

in these modes and between these thresholds.

- In Sport mode, the adaptive main beam headlights will switch on when the vehicle speed is over approximately 25 mph (40 km/h) and switch off when the speed is below approximately 19 mph (30 km/h).

Switching off the lights



61290

The lights will go out automatically when the driver's door is opened or the vehicle is locked, or one minute after the engine is switched off.

In this case, the next time the engine is started the lights will be switched back on according to the position of the ring **3**.

LIGHTING AND SIGNALS

Lights-on reminder buzzer

If the lights are on after the engine is switched off, a warning beep sounds when the driver's door is opened to warn you that the lights are still on.

Operating faults

Depending on the vehicle, if the "Check lighting" message appears

along with the  warning light

and/or the  warning flashes on the instrument panel, this indicates a lighting fault.

Consult an approved dealer.

"Welcome and Goodbye" function

(depending on the vehicle)

Once the function is activated, the daytime running lights and the rear side lights will light up automatically upon detection of the card or when the vehicle is unlocked.

They switch off automatically:

- approximately 15 seconds after they are switched on;
- when starting the engine, based on the position of the lighting stalk;
- or
- upon locking the vehicle.

Activating/deactivating the function

For activation or deactivation of the external welcome, refer to the multimedia instructions.

"See-me-home lighting"



61290

This function enables you to briefly switch on the side lights and dipped beam headlights (e.g. to provide light when opening a gate).

With the engine off, after opening the driver's door, with the ring **3** in "AUTO" position, pull the handle **1** towards you: the side lights and dipped beam headlights will switch on for approximately 30 seconds along with the



warning lights on the instrument panel.

To increase this duration, you may pull the stalk up to four times (total time restricted to approximately two minutes).

The "Lighting on during ___" message appears with the lighting time on the instrument panel to confirm the action. You can then lock your vehicle.

Deactivating the "See-me-home lighting" function

To switch off the lighting before it is done automatically, rotate the ring **3** to any position then return it to the "AUTO" position.

Note: if the "Welcome and Goodbye" function is activated, once the engine is switched off, the procedure for deactivating the "See-me-home lighting" function must be carried out before pulling the stalk (otherwise the lights remain lit by the Welcome and Goodbye function).

LIGHTING AND SIGNALS

Rear fog light

61290



 To activate this function, rotate the ring **3** until the "AUTO" symbol is opposite the mark **2**, then press the rotary switch to align the mark **4** with the symbol **7**.

Warning light  comes on the instrument panel.

Operation of the fog lights depends on the exterior lighting selected, and an indicator light will light up on the instrument panel.

To avoid inconveniencing other road users, remember to switch off this light when it is no longer needed.

Switching off the lights

To deactivate the function, rotate the rotary switch again so that the mark **4** is opposite the symbol **7**.

The warning light  disappears from the instrument panel.

The rear fog lights switch off when the exterior lights are switched off.

 When driving in fog or snow, or when transporting objects which are higher than the roof, the headlights do not come on automatically.

The fog lights are controlled by the driver: the warning lights on the instrument panel inform you whether they are on (warning light on) or off (warning light off).

Headlight beam adjustment

61275

2



Depending on the vehicle, the switch **A** can be used to adjust the height of the headlight beams according to the load.

With the dipped beam headlights on, press or raise switch **A** as many times as required to select the required position on the instrument panel.

Note: if the lights are on, at each engine start-up the selected position is displayed on the instrument panel for approximately 15 seconds.

LIGHTING AND SIGNALS

2

	Examples of positions for adjusting the switch A according to the load
Driver alone or with front passenger	0
All seats occupied	1
Driver with passengers and luggage (or load) reaching the maximum permissible all-up weight	3
Driver without passengers and luggage (or load) reaching the maximum permissible all-up weight	4

The table below gives some examples. In all cases, adjust the control **A** according to the vehicle load so that the road can be seen and other drivers are not dazzled.



When driving on the left-hand side of the road in a left-hand drive vehicle (or vice versa), you must adjust your headlights for the length of your stay.

AUDIBLE AND VISUAL SIGNALS

Horn



Press the steering wheel boss **A** to sound the horn.

Headlight flasher

To flash the headlights, pull the stalk **1** towards you, then release.

Direction indicators

Move the stalk **1** in the same direction as you want to move the steering wheel.

One-touch mode

Briefly shift the stalk **1** upwards or downwards, not exceeding the point of resistance, then release it: the stalk

will return to its original position and the direction indicator light concerned will flash three times.

Hazard warning lights



 Press the switch **2**.

This switch activates all four direction indicators and the side indicator lights simultaneously. It must only be used in an emergency to warn drivers of other vehicles that you have had to stop in an area where stopping is prohibited or unexpected, or that you are obliged to drive under special conditions.

WIPER

Windscreen wash, wipe

2 Vehicle fitted with front windscreen wiper rain sensor

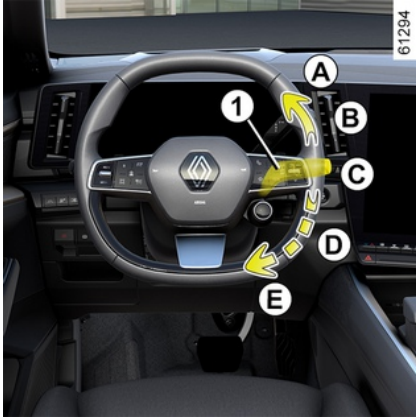

The rain sensor is located on the windscreen, in front of the interior rear view mirror.

A. a single sweep of the wipers

A short push will trigger one sweep of the wipers.

B. stopping

C. automatic wiper function

When this position is selected, the system detects water on the windscreen and triggers the wipers at a suitable wiping speed.

You can change the triggering threshold and the time interval between sweeps by pressing the rotary switch once **2**:

– **G**: minimum sensitivity;

– **F**: maximum sensitivity.

The higher the sensitivity, the quicker the wipers will react and the faster the wipe.

When activating automatic wiping or when increasing sensitivity, one sweep of the blades is performed.

The  warning light appears on the instrument panel to confirm that the function is activated.

Note:

– the rain sensor is only intended as a driving aid. In the event of reduced visibility, the driver should manually activate the wipers. In foggy weather or during snowfalls, wiping is not automatically triggered and remains under the driver's control;

– in the event of temperatures below zero, automatic wiping is not activated when the vehicle is started. It is automatically activated as soon as the vehicle exceeds a certain speed (approximately 5 mph (8 km/h));

– do not activate automatic wiping in dry weather;

– fully de-ice the windscreen before activating automatic wiping;

– when washing the vehicle under a roller type car wash, set the stalk **1** to position **B** to deactivate automatic wiping.

WIPER

Operating faults

In the event of a malfunction of the automatic wiping, the wiper is set to intermittent wiping. Call an approved dealer.

The rain sensor operation may be interrupted in the event of:

- damaged windscreen wipers – a film of water or traces left by a blade in the sensor's detection zone may increase the response time of the automatic wiper, or increase the wiping frequency;
- a windscreen with any chip or crack near the sensor, or a windscreen covered in dust, dirt, insects, ice, the use of washing wax and water-repellent chemicals. The windscreen wiper will be less sensitive or may even not react at all.

D. slow continuous wiping

E. fast continuous wiping

Special feature

When driving the vehicle, the wiping speed slows down whenever the vehicle stops. For example, fast wiping speed will slow to normal wiping speed. As soon as the vehicle moves off, wiping will return to the speed originally selected.

Any action on the stalk **1** overrides and cancels the automatic function.

Precautions

- In the event of ice, check whether the blades are stuck to the windscreen before operating the wiping mechanism. If you activate the wipers while the blades are stuck down with ice, you may risk damaging both the blade and the wiper motor.
- Do not activate the wipers on a dry screen. This will lead to premature wear or damage to the blades.

Specific front wiper position (service position)

This position enables the blades to be lifted to remove them from the windscreen.

It may be useful to:

- clean the blades;
- release the blades from the windscreen in winter;
- replace the blades → 364.

With the ignition on or engine started, lift the stalk **1** twice to position **A** (single sweep). The blades stop slightly away from the bonnet.

To return the blades to the lowered position, with the ignition on, ensure that the wipers have folded down onto the windscreen, then move the stalk **1** to position **A** (single sweep).

Before switching on the ignition, place the wipers on the windscreen. Other-

wise, there may a risk of damage to the bonnet or the wipers when they are switched on.

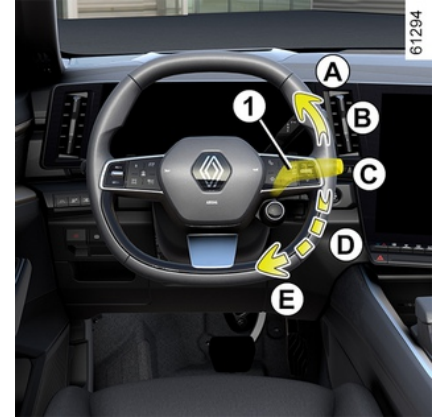

Before any action involving the windscreen (washing the vehicle, de-icing or cleaning the windscreen, etc.) return the stalk **1** to position **B** (park).

Risk of injury and/or damage.

WIPER

i In the event of obstacles on the windscreen (dirt, snow, ice etc.), clean the windscreen (including the central area located behind the interior rear view mirror) before starting the wipers (risk of motor overheating). If an object is preventing a blade from moving, it may stop functioning. Remove the obstacle and reactivate the wiper using the wiper stalk.

Windscreen washer

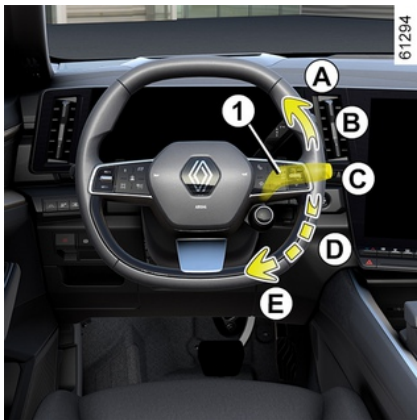

With the ignition on, pull the stalk **1** then release.

A longer pull will trigger, in addition to the windscreen washer, two sweeps of the wipers followed, a few seconds later, by a third.

Note:

- A front washing action at stalk **1** lasting for more than 30 seconds may cause the windscreen washer pump to cut out. **This prevents the pump from overheating;**
- in temperatures below zero, the washer liquid risks freezing to the windscreen, thereby reducing visibility. Heat the windscreen using the demister control before cleaning.



When working in the engine compartment, ensure that the windscreen wiper stalk is in position

B (stop).
Risk of injury.

i **Efficiency of a wiper blade**

Check the condition of the wiper blades. How long they last depends on you:

- it must remain clean: clean the blade and the screen regularly with soapy water;
- do not use it when the screen is dry;
- free it from the screen when it has not been used for a long time.

In all cases, replace it as soon as it begins to lose efficiency: approximately once a year → **364**.

Precaution for using the wipers

- In freezing or snowy conditions, clear the screen before starting the wipers (risk of motor overheating);
- ensure that no objects are obstructing the travel of the blade.

FUEL TANK

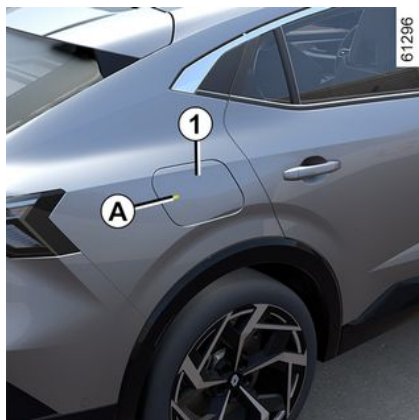

Usable capacity of tank: approximately 12.1 gallons (55 litres).

With the vehicle unlocked, to open the flap **1**, press zone **A**, then release. The flap **1** opens slightly.

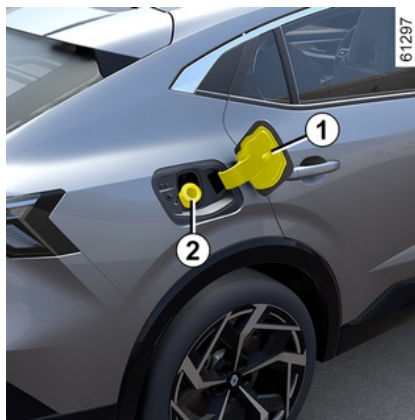

The valve **2** is built into the filler pipe. For details on filling the tank, refer to the information on "Filling with fuel". To close it, press on the fuel filler flap by hand, as far as it will go.



Never press the valve **2** using your fingers. Do not wash the filler area with a high pressure washer.

Special feature of E-Tech plug-in hybrid versions

Your rechargeable hybrid vehicle is equipped with a specific tank to limit

petrol vapour fumes and to prevent any release when the cap is opened.



With the vehicle stationary, unlocked and the ignition off, to open the flap **1** press the switch **B**.

The internal pressure of the tank is automatically compensated. The message "Preparation for Filling Tank" appears on the instrument panel.

It may take up to 10 seconds to open the flap **1**.

The "Ready for Filling Tank" message appears on the instrument panel to confirm that the flap **1** has been opened.

Loosen the cap **4**.

2

FUEL TANK

2

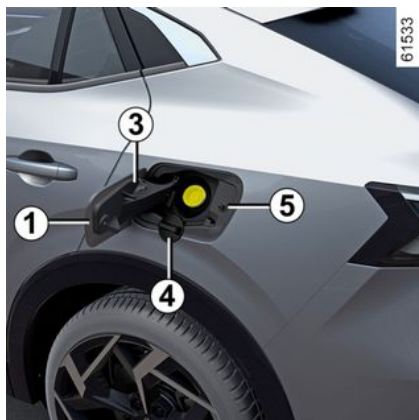

Use the cap holder **3** on the flap **1** during filling to hold the cap **4** in place.

To close the cap, screw it until the lock clicks.

To close the flap, press the cover with your hand, as far as it will go.

Note: if the flap **1** cannot be locked, ensure that the actuator **5** is not pushed in. In this case, press the switch **B** for more than three seconds to unlock it. The actuator will be released from its housing. To close it, press on the fuel filler flap by hand, as far as it will go.

If the fuel vapour management system encounters a fault, the "Tank failure see manual" warning message ap-

pears on the instrument panel and the flap **1** remains locked.

Consult an approved dealer.

Fuel grade

Use a high-grade fuel that complies with the legislation in force in each country and that complies with the specifications given on the label on the flap **1 → 376.**



After filling, check that the cover is closed.



Do not use ethanol-based fuel if your vehicle is not compatible with this fuel.

Do **not** add reagent to the fuel – otherwise you risk damaging the engine.

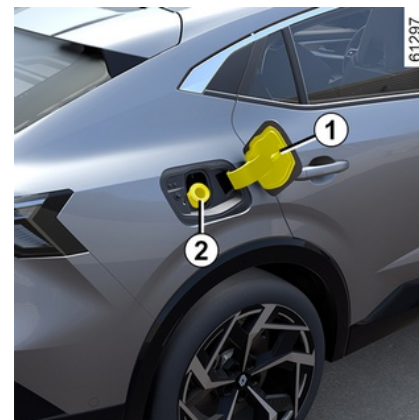

It is **essential** to use unleaded petrol. The octane rating (RON) must comply with the information shown on the label on the fuel filler flap **1** → 376.

Filling with fuel

On E-Tech plug-in hybrid vehicles, to prevent splashing fill your tank within 30 minutes after opening the flap. After this time period, close the cap **4** and the flap **1** then restart the procedure to open the tank.

With the ignition off, insert the nozzle and push (depending on the vehicle) the valve **2**, inserting it **as far as possible** before pulling the nozzle trigger to fill the tank (avoid the risk of splashing).

FUEL TANK

Keep the nozzle in this position throughout the entire filling operation.

When the pump cuts out automatically at the end of the filling procedure, a maximum of two further filling attempts may be made, as there must be sufficient space in the fuel tank to allow for expansion.

Make sure that no water enters the fuel tank during filling. The flap **1** and its surround must remain clean.



After locking the vehicle, if the flap **1** is still open, you can close it but it will not be locked.
To lock the flap **1**, unlock the vehicle then lock it again

Special case

When the vehicle has been stopped for around three months, **you must add fuel to prevent damage to the fuel pump.**

To do this, with the ignition off, top-up at least 1.10 gallons (**5 litres**) then start the engine to operate the pump and renew the fuel in the circuit.

If it is not possible to add at least 1.10 gallons (5 litres) of fuel due to the fuel

level in the tank, drive the vehicle until the tank has capacity.

Special case for E-Tech plug-in hybrid versions

Depending on vehicle usage, if the combustion engine does not start for a long time, the fuel quality is likely to degrade, which may result in damage to the engine components and the fuel supply system.

When using the vehicle exclusively in electric mode or in the event of prolonged immobilisation, the vehicle must be refilled with at least **10 litres** at least once every three months. After six months without refuelling, and if the amount of fuel in the tank allows you to refill at least **10 litres**, the "Old fuel Fill 10 L mini" message will appear on the instrument panel.

If the amount of fuel in the tank does not allow you to refill at least 10 litres, the "Old fuel Fill at least 10 litres" message will not appear and priority will be given to hybrid mode. Please drive the vehicle long enough to reduce the fuel level. . The "Old fuel Fill 10 L mini" message will appear when the amount available in the tank allows the refilling of at least 10 litres and the refilling can then take place.

Do not recharge your vehicle, allow driving in hybrid mode. This will facili-

tate fuel consumption to enable you to top up.



To fill up with fuel, the engine must be off: you must switch off the ignition ➔ **160.**

Using leaded petrol will damage the antipollution system and may lead to a loss of warranty.

To ensure that the fuel tank is not filled with leaded petrol, the fuel tank filler neck contains a restrictor fitted with a foolproof system which **only allows the nozzle for unleaded petrol to be used** (at the pump).



Fuel types that conform to European standards with which the engines of vehicles sold in Europe are compatible: refer to the table ➔ **376.**

FUEL TANK

2



Persistent smell of fuel

If you notice a persistent fuel odour you should:

- stop the vehicle when traffic conditions allow it and switch off the ignition;
- switch on the hazard warning lights and ask your passengers to leave the vehicle and stay clear of the traffic;
- contact an authorised dealer.



No modifications whatsoever are permitted on any part of the fuel supply system (electronic

units, wiring, fuel circuit, injectors, protective covers, etc.) as this may be dangerous (unless undertaken by qualified Network personnel).

RUNNING IN

For the first **620 miles** (1,000 km) do not exceed 80 mph (130 km/h) in the highest gear, or 3,000 to 3,500 rpm.

You can only expect top performance from your vehicle after approximately **1,860 miles (3,000 km)**.

Note: for a new vehicle in the running-in phase: the coolant level may exceed the mark MAXI " on the tank, then drop between the " MINI " and " MAXI ». This does not present a risk.

Service intervals: refer to your vehicle's maintenance document.

STARTING, STOPPING THE ENGINE

Starting



61233



61299



Before carrying out any operation in the engine compartment, you must switch off the ignition.

Special features

- If one of the conditions required for starting is not met, the "Press brake pedal + START" or "Set gearbox to P" message is displayed on the instrument panel;
- in some cases it is necessary to move the steering wheel while pressing the start button **2** to help unlock the steering column – in this case

the Turn steering wheel + START" message will inform you.

 Depending on the vehicle, you may have a digital key that offers all the functions of the card.

However, if a card has been left inside the vehicle and the doors have been locked with a digital key, all of the card's functions will be inhibited.

For further information, please see the "Digital key" section ➔ **58**.

Note:

- the engine unit will switch off automatically after approximately 15 minutes if the vehicle has remained stationary and the driver's seat belt has not been fastened. If necessary, you can restart the engine by pressing the button **2** once.

STARTING, STOPPING THE ENGINE



During a system update via the multimedia system it will not be possible to start the vehicle.

Wait for the update to be completed before starting the vehicle.

For more information on system updates, please refer to the multimedia instructions.

"Hands-free" starting with the luggage compartment open



In this case, the card should not be located in the luggage compartment, to prevent the risk of loss.

Accessories function

(switching on the ignition)

Once you have gained access to your vehicle, you may use some of its functions (radio, navigation, wipers, etc.).

To use the other functions, with the card in the passenger compartment, press the button **2** without pressing the pedals.



The "Place card in zone + START" message appears on the instrument panel.

Press the brake pedal, then place the card **4** (button side) on the placement area **3**. Press the button **2** to start the vehicle. The message goes out.

Operating faults

In certain cases, the hands-free card may not work:

- when the card battery is flat, etc.;
- when near to appliances operating on the same frequency as the card (monitor, mobile phone, video game, phone charger, etc.);
- the vehicle is located in a high electromagnetic radiation zone.

Conditions for stopping the engine



The vehicle must be stationary, with the lever in **P** position. The READY message is displayed on the instrument panel.

STARTING, STOPPING THE ENGINE

With the card in the vehicle, press the button **2**: the engine is switched off. The READY message disappears from the instrument panel.

The steering column is locked when a door is opened or the vehicle is locked. If the card is no longer in the passenger compartment when you try to switch the engine off, the "Card missing: press and hold START" message appears on the instrument panel: press button **2** for at least two seconds. If the card is no longer in the passenger compartment, make sure you can retrieve it before pressing and holding the button. Without the card, you will not be able to restart the vehicle.

With the engine switched off, any accessories being used (radio, etc.) will continue to function for approximately 10 minutes.

When the driver's door is opened, the accessories stop working.

Special case of vehicles E-Tech full hybrid

With the vehicle stationary and in electric operating mode, the "ENGINE ON SWITCH OFF IGNITION" message appears on the instrument panel accompanied by a beep if:

- the driver's seatbelt is not fastened;

- the bonnet is open;
- the driver's door is open.



Never switch off the ignition before the vehicle has stopped completely. Once the engine has stopped, the brake servo, power-assisted steering and passive safety devices, such as the airbags and pretensioners, will no longer operate.



When you leave your vehicle, especially if you have your card with you, check that the engine is completely switched off.



Driver's responsibility when parking or stopping the vehicle

Never leave an animal, child or adult who is not self-sufficient alone in your vehicle, even for a short time.

They may pose a risk to themselves or to others by starting the engine, activating equipment such as the electric windows or locking the doors.

Also, in hot and/or sunny weather, please remember that the temperature inside the passenger compartment increases very quickly.

RISK OF DEATH OR SERIOUS INJURY.

GEAR CONTROL

Automatic gearbox

Electronic selector lever 1



R: reverse gear

N: neutral

D: automatic mode

P: parking, button 2

The gear engaged is displayed on the instrument panel.

One-touch selector



Move the selector lever **1** one or two notches upwards or downwards to engage the desired position (R, N or D) then release the lever and it will return to the stable position.

The position engaged lights up on the instrument panel.

If certain conditions prevent shifting from one position to another, the current position flashes on the instrument panel.



To engage position P



GEAR CONTROL

With the vehicle at a standstill and the engine or the ignition on, press the button **2** to engage the position **P**.

To disengage position P

With the vehicle stationary and the engine on, press the brake pedal and move the selector lever **1** upwards or downwards according to the position desired.

If the brake pedal is not pressed down fully, the "Press brake pedal" message

and the  warning light are displayed on the instrument panel.

To engage neutral

With the vehicle stationary and the engine on, to engage **N** position, it is necessary to press the brake pedal before moving the selector lever **1** one notch upwards or downwards.



Check that the **P** indicator light is displayed on the instrument panel before leaving the vehicle.

Risk of loss of immobilisation of the vehicle

Driving in automatic mode

With the vehicle stationary, the engine on and your foot on the brake pedal, move the selector lever **1** two notches downwards to engage **D** position.

The gears will change automatically at the right time and at the most suitable engine speed as the automatic system takes into account the vehicle load and road contour and adjusts itself to the particular driving style you have chosen.

Note: with the engine running and the vehicle travelling at between 0 and 5 mph (0 and 8 km/h), in position **N** or **R**, it is necessary to depress the brake pedal to engage position **D**.

Economical driving

When driving, always leave the lever in position **D**, keeping the accelerator pedal lightly depressed to ensure automatic gear changes at a lower engine speed.

Accelerating and overtaking

Depress the accelerator pedal briskly and fully (so that it goes beyond the kickdown point).

It is also possible to shift down at any time for overtaking purposes, by pressing the left-hand paddle.

To select reverse gear

With the vehicle stationary and the engine on, move the selector lever **1** two notches upwards to engage **R** position.

If the brake pedal is not pressed, a beep will sound, the **R** position will flash for approximately five seconds on the grid displayed on the instrument panel and the "Press brake pedal" message is displayed for approximately five seconds.

Note: with the engine running and the vehicle travelling at between 0 and 5 mph (0 and 8 km/h), in position **N** or **D**, it is necessary to depress the brake pedal to engage position **R**.

Special cases

In certain driving conditions (e.g. requiring engine protection, operation of the Electronic Stability Program: ESC, etc.) the system may change the gear automatically.

Likewise, to prevent incorrect manoeuvres, a gear change may be refused by the automatic system: in this case the gear display flashes for a few seconds as a warning.

Special circumstances

– **If the road type or weather conditions** (steep uphill slopes, sudden downhill slopes, deep snow, sand or

GEAR CONTROL

mud) make it difficult to stay in automatic mode. On vehicles equipped with gear shift paddles, it is advisable to change to manual mode using the paddles. This will prevent the automatic gearbox from changing gears repeatedly when driving uphill, and permit engine braking on long descents.

– **In very cold weather**, to avoid the engine stalling, wait a few seconds before moving the selector lever from position P or N and engaging the lever in D or R.

Parking the vehicle

P position is engaged automatically and the electronic parking brake (if the vehicle is equipped) is applied when:

- the engine is stopped;
- the driver's seatbelt is unfastened and the vehicle is stopped;

and

- the driver's door is opened and the vehicle is stopped.

P is displayed on the instrument panel.

As position **P** is **automatically engaged** when the engine is stopped, it is sometimes necessary to place the vehicle in position **N** for some car washes, for example:

- With the engine running, press the **P** button, shift the selector lever **1** a

notch upwards or downwards then switch off the engine.

- With the engine off and the ignition on, shift the selector lever **1** one notch upwards or downwards.

The next time the engine is restarted, position **P** is engaged automatically according to the cases described earlier.



The **P** position must only be engaged when the vehicle is stationary.



When facing uphill, to remain stopped, do not keep your foot on the accelerator.

Risk of overheating the automatic gearbox.



For safety reasons, do not switch off the ignition before the vehicle has come to a complete standstill.

Maintenance period

Refer to the maintenance document for your vehicle or consult an Approved Dealer to check whether the automatic gearbox requires scheduled maintenance.

If it does not need to be serviced, there is no need to top up the oil.

Operating faults

– **when driving**, if the "Check gearbox" message appears on the instrument panel this indicates a fault.

Contact an approved dealer as soon as possible;

– **when driving**, if the "Gearbox overheating" or "Cool the gearbox: stop temporarily" message appears on the instrument panel, stop as soon as possible to enable the gearbox to cool until the message disappears;

– **when driving**, if the "Risk of gearbox failure" message appears on the instrument panel, the engine performance is deliberately limited in order to maintain the gearbox.

Contact an approved dealer as soon as possible;

– **breakdown recovery of a vehicle with an automatic gearbox → 356.**

GEAR CONTROL



An impact to the underside of the vehicle while manoeuvring (e.g. striking a post, raised kerb or other street furniture) may result in damage to the vehicle (e.g. deformation of an axle).

To avoid any risk of accident, have your vehicle checked by an approved dealer.

In the event of engine failure or an electrical fault (battery fault) affecting operation of the automatic gearbox, ensure that the vehicle is properly immobilised.

If the "Auto gearbox P failure" message appears on the instrument panel, **P** position cannot be engaged. Be sure to secure the vehicle with the electronic parking brake and consult an approved dealer.

REGENERATIVE BRAKING SYSTEM

Regenerative braking change paddles 1 and 2



You can use paddles **1** and **2** to change the regenerative braking level when the lever is in D position.

1: increases regenerative braking (-).
2: decreases regenerative braking (+).

The paddles can only be used while the lever is in D position.

It is not possible to use the paddles while adaptive cruise control is activated → **252**.



By releasing the accelerator, the vehicle uses regenerative braking to slow down the vehicle.

Some of this energy is converted to electricity to recharge the traction battery.



The engine brake should under no circumstances be used as a substitute for the brake pedal.

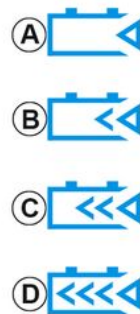

Regenerative braking levels

The **3** warning light informs you of the regenerative braking level:

- **A**: "Free-wheel" level for gentle, economical driving. Requires driving with anticipation;
- **B**: low regenerative braking level;
- **C**: average regenerative braking level;
- **D**: maximum regenerative braking level.

If the traction battery is no longer able to absorb energy (e.g. fully charged or cold battery), the conventional braking system replaces the regenerative braking system while maintaining its functions.

REGENERATIVE BRAKING SYSTEM

However, the pedal may appear more depressed and feel firmer. This is normal.

To limit this effect, use the regenerative braking levels **A** and **B**.

3

SPECIAL FEATURES OF PETROL ENGINES

The following operating conditions:

- driving for long periods when the low fuel level warning light is lit;
- using leaded petrol;
- using lubricant or fuel additives which are not approved.

Or operating faults such as:

- a faulty ignition system, running out of fuel or disconnected spark plugs resulting in the engine misfiring or jerkiness while driving;
- loss of power.

may cause the catalytic converter to overheat, reducing its efficiency **which may irreparably damage it and cause heat damage to the vehicle.**

If you notice any of the above operating faults, have the necessary repairs carried out as soon as possible by an approved dealer.

These faults may be avoided by regularly taking your vehicle to an approved Dealer at the intervals specified in the maintenance document.

Starting problems

To avoid damaging the catalytic converter or the starter, and to prevent premature wearing of the battery, **do not keep trying to start the engine (using the start button, or by pushing or towing the vehicle) without**

having identified and corrected the starting fault.

If the fault cannot be identified, do not keep trying to start the engine, but contact an approved Dealer.





Do not park the vehicle or run the engine in locations where combustible substances or materials

such as grass or leaves can come into contact with the hot exhaust system.

Particle filter

The particle filter is used in the treatment of exhaust gases from petrol engines.

Depending on the vehicle, the  warning light is displayed on the instrument panel to indicate that the filter is becoming saturated and requires

cleaning. To do this, once the  warning light appears, and as traffic conditions and speed limits allow, drive at between about 31 mph (50 km/h) and 68 mph (110 km/h) until the warning light goes out.

After between approximately 5 and 20 minutes, the warning light should go out.

Note: the warning light may go out after 20 minutes if the driving conditions required to clean the filter are not fully met.

If the vehicle is stopped before the warning light disappears you will have to restart the process from the beginning.

If the filter is too saturated, the



warning light, and depending

on the vehicle, the  light up on the instrument panel accompanied by the "Check injection" message. In this case, please consult an Authorised Dealer.

If the **STOP** warning light, and de-

pending on the vehicle, the  light up, accompanied by the "Risk of engine failure" message, stop the vehicle, switch off the engine and contact an approved dealer.

SPECIAL FEATURES OF PETROL ENGINES



The warning light

STOP for your own

safety, it requires you to stop immediately as soon as traffic conditions allow. Switch off the engine and do not restart it. Call an approved Dealer.

3

PARKING BRAKE

Electronic parking brake

Assisted operation

Applying the electronic parking brake



With the vehicle stationary, the electronic parking brake can be used to immobilise the vehicle:

- by pressing the engine start/stop button **1**;

or

- when the driver's seat belt is unfastened;

or

- when the driver's door is opened;

or

- when **the P position is engaged**.

In all other instances, e.g. **if the engine stalls**, the electronic parking brake is not applied automatically. Manual mode must be used. For certain country-specific model versions, the assisted brake application function is not activated. See the information on "Manual operation".



To confirm that the electronic parking

brake is applied, the **(P)** warning light appears on the instrument panel and the indicator light **2** lights up on the switch **3**.

After the engine is switched off, the indicator light **2** goes out a few minutes

after the electronic parking brake has

been applied and the **(P)** warning light goes out when the vehicle is locked.

Note: in some situations (electronic parking brake failure, manual release of the parking brake, etc.), a beep sounds and the "Apply parking brake" message appears on the instrument panel to indicate that the electronic parking brake has been released:

- with the engine on: when the driver's door is opened;
- with the engine off (e.g. when the engine stalls): when a front door is opened.

In this case, pull and release the switch **3** to apply the electronic parking brake.

PARKING BRAKE



The electronic parking brake can be used to immobilise the vehicle. Before leaving the vehicle, check that the electronic parking brake is fully applied. Application of the parking brake is confirmed by the illumination of the indicator light **2** on the switch **3** and the

 warning light on the instrument panel until the doors are locked. Depending on the vehicle, a sticker is located on the upper section of the windscreen to remind you of this.

Assisted release of the parking brake

The parking brake is released:

- once the vehicle starts to accelerate;
- or
- when shifting from P position.

Manual operation

You can apply the electronic parking brake manually.

Manually applying the electronic parking brake



Pull the switch **3**. Warning light **2** and

warning light  on the instrument panel light up.



The electronic parking brake can be used to immobilise the vehicle. Before leaving the vehicle, check that the electronic parking brake is fully applied. Application of the parking brake is confirmed by the illumination of the indicator light **2** on the switch **3** and the

 warning light on the instrument panel until the doors are locked.

Depending on the vehicle, a sticker is located on the upper section of the windscreen to remind you of this.

PARKING BRAKE

Manually releasing the electronic parking brake



Press the switch **1** without pressing the pedals to switch the ignition on. Press the brake pedal then press switch **3**: indicator light **2** on the

switch and indicator light  displayed on the instrument panel go out.

Brief stop



To apply the electronic parking brake manually (when stopping at a red light, stopping when the engine is running, etc.): pull and release the switch **3**. The brake is released as soon as the vehicle is started up again.

Special cases

To park on a slope or while towing a trailer, for example, pull switch **3** for a few seconds to enable maximum braking.

To park, with the electronic parking brake released (if there is a risk of freezing, for example):

- engage **P** position: the drive wheels are mechanically locked by the drive-shaft;
- stop the engine by pressing the engine Start/Stop button **1**;
- unfasten the driver's seat belt;
- open the driver's door;
- manually release the electronic parking brake (please see the paragraph on "Manually releasing the electronic parking brake");
- depending on the vehicle, the parking brake is applied automatically. You will have to release it manually.



If no lights or sounds are apparent, this indicates a fault in the instrument panel. This indicates that it is essential to stop immediately (as soon as traffic conditions allow). Ensure that the vehicle is correctly immobilised and contact an approved Dealer.

PARKING BRAKE





Never leave your vehicle without re-engaging **P** position and switching off the engine. This is because when the vehicle is stationary with the engine running and a gear engaged, the vehicle may begin to move if you accelerate.

There is a risk of accidents.

Operating faults

– In the event of a fault, the warning

light  lights up on the instrument panel accompanied by the "Check parking brake" message and in

some cases the warning light . Contact your approved Dealer straight away.

– In the event of an electronic parking brake fault, the warning light  lights up accompanied by the "Braking system fault" message, a beep, and in

some cases the warning light . This means that you must stop as soon as traffic conditions allow.

Versions with an automatic gear-box

For safety reasons, automatic release is deactivated when the driver's door is open or not shut properly and the engine is running (in order to prevent the vehicle from moving without the driver).

The "Release Parking Brake" message appears on the instrument panel when the driver presses the accelerator pedal.



If the "Electric System Failure" or "Check battery" or "WARNING: Braking System" message appears, you must immobilise the vehicle by engaging the first gear (manual gearbox), **P** position (automatic gearbox) or by pulling the switch **3** for approximately 10 seconds.

If the conditions and the slope require it, chock the wheels of the vehicle.

Risk of loss of immobilisation of the vehicle.

Call an approved dealer.

"Autohold" function

Vehicle stopped (e.g. at a red light, an intersection, a traffic jam, etc.), the function ensures braking force even when the driver releases the brake pedal.

The braking force is released as soon as the driver accelerates sufficiently with a gear engaged.

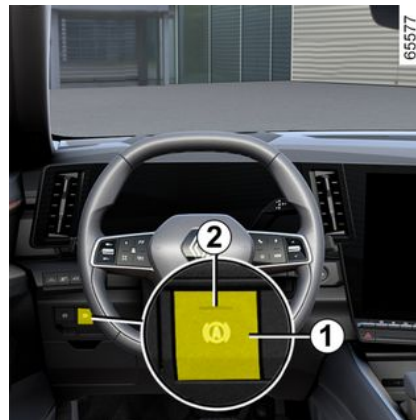

Activation

Press the switch **1**.

The warning light on the switch **1** comes on to confirm that the function is activated.

PARKING BRAKE

Deactivation

Press the switch **1**. If your vehicle is maintained by braking force you can also press the brake pedal.

The warning light on the switch **1** disappears to confirm that the function is deactivated.

If the braking force is maintained, the parking brake is applied automatically when:

- the driver opens the door;
- or
- the driver unfastens their seat belt;
- or
- the vehicle is immobilised for more than approximately three minutes.



Upon each start-up, the function continues the mode set at the time the engine was last switched off.



The electronic parking brake can be used to immobilise the vehicle. Before leaving the vehicle, check that the electronic parking brake is fully applied. The indicator light is lit on switch **2** and the



warning light appears on the instrument panel until the doors lock. Depending on the vehicle, a sticker is located on the upper section of the windscreen to remind you of this.

Conditions for maintaining the braking force

The following conditions must be met:

- the driver's door is closed;
- and
- the driver's seat belt is fastened;
- and
- the electronic parking brake is released;
- and
- the vehicle is not stationary on a very steep slope.

The maintained braking force is confirmed by the warning light on the instrument panel.

Conditions for interrupting the braking force

The following conditions must be met:

- the driver accelerates sufficiently with a gear engaged;
- or
- the driver disables the function.

Warning light goes out on the instrument panel.

ENVIRONMENT

Your vehicle has been designed with respect for the **environment** in mind for its entire service life: during its production, usage and at the end of its service life.

3 **Manufacture**

Your vehicle has been manufactured at a factory which complies with a policy to reduce the environmental impact on the surrounding areas (reduction of water and energy consumption, visual and noise pollution, atmospheric emissions and waste water; sorting and reusing waste).

Emissions

Your vehicle has been designed to emit fewer greenhouse gases (CO₂) while in use, and therefore to consume less fuel (e.g. 160.9 g/mile (100 g/km), equivalent to 0.92 gal (4.2 l)/62 miles (100 km) for a petrol vehicle). Our vehicles are also equipped with an emission control system including a catalytic converter, an oxygen sensor and an active carbon filter (the latter prevents vapour from the fuel tank being released into the open air).

Please make your own contribution towards protecting the environment too.

– Parts and vehicles at the end of their life must not be thrown away. They

must be handed to a legal entity that complies with environmental standards.

- Worn parts replaced in the course of routine vehicle maintenance (vehicle battery, oil filter, air filter, batteries, etc.) and oil containers (empty or filled with used oil) must be disposed of at dedicated collection points.
- To optimise the recycling of your vehicle at the end of its life, you can contact an authorised dealer or visit the manufacturer's website to be directed to collection points that guarantee respect for the environment complying with local laws.

Recycling

Your vehicle is 85% recyclable and 95% recoverable.

To achieve these objectives, many of the vehicle components have been designed to enable them to be recycled. The materials and structures have been carefully designed to:

- allow these components to be easily removed and reprocessed by specialist companies;
- promote a circular economy (re-use, recycling, recovery, etc.)

This is particularly true for electrified vehicle batteries.

In order to preserve raw material resources, your vehicle also includes

many parts made from recycled plastics or renewable materials.

MAINTENANCE AND ANTIPOLLUTION ADVICE

Your vehicle complies with criteria for recycling and recovering vehicles at the end of their service life, which entered into force in 2015.

Some of the parts on your vehicle have been designed to be recycled later.

These parts are easily removable in order to be collected and reprocessed in recycling networks.

Furthermore, by virtue of its design, moderate fuel consumption and initial settings, your vehicle also conforms to current anti-pollution regulations. The manufacturer is actively striving to reduce pollutant exhaust gas emissions and to save energy. But the fuel consumption of your vehicle and the level of pollutant exhaust gas emissions are also your responsibility. Ensure that it is maintained and used correctly.

Maintenance

It is important to remember that failure to respect antipollution regulations could lead to legal action being taken against the vehicle owner.

In addition, replacing engine, fuel supply system and exhaust components with parts other than those originally recommended by the manufacturer may alter your vehicle so that it no

longer complies with antipollution regulations.

Have your vehicle adjusted and checked by an approved dealer, in accordance with the instructions given in your maintenance schedule: they will have all the equipment necessary for ensuring that your vehicle is maintained to its original standard.

Engine adjustments

- **Spark plugs:** for optimum fuel economy, efficiency and performance, the specifications which have been laid down by our Design Department must be strictly applied.

If the spark plugs have to be changed, use the make, type and gap specified for your vehicle's engine. Contact an authorised dealer for this.

- **Ignition and idle speed:** no adjustment is needed.
- **Air filter, fuel filter:** a choked element hinders performance. It must be replaced.

Exhaust gas monitoring system

The exhaust gas monitoring system will detect any operating faults in the vehicle's exhaust gas antipollution system.

If this system malfunctions, toxic substances may be released into the at-

mosphere or mechanical damage may occur.



This indicator light on the instrument panel indicates possible faults in the system.

This lights up when the ignition is switched on and goes out when the engine is started.

- If it lights up continuously, contact an approved dealer as soon as possible;
- If it flashes, reduce the engine speed until the light stops flashing. Contact your approved Dealer as soon as possible;

DRIVING ADVICE, ECO-DRIVING

Eco-driving

Fuel consumption is accredited in accordance with a standard regulatory method. Identical for all manufacturers, this enables vehicles to be compared with one another.

Consumption in real time depends on vehicle usage conditions, equipment fitted and the user's driving style. To optimise fuel consumption, please refer to the following advice.

Depending on the vehicle, you have different functions to help you reduce your fuel consumption.

On the instrument panel:

- the rev counter;
- the gear change indicator;
- the driving style indicator;
- ECO mode;
- the power meter.

On the multimedia screen (for more information, see the multimedia system user manual):

- data relating to your energy consumption;
- an energy consumption graph;
- scores based on your driving style;
- ECO driving advice;
- the journey record and eco-driving advice via the multimedia screen;
- ECO driving mode.

On the instrument panel A



Depending on the vehicle, you can customise the instrument panel with different types of information.

Driving style indicator 2



The eco-monitor **3** is a real-time indicator of your driving style. It can help you to reduce your consumption by providing suitable advice.

You can display the driving style indicator by repeatedly pressing upwards/downwards on the switch **1**.

The larger the indicator leaf **2**, the better the management of speed, acceleration and anticipation in terms of eco-driving.

The smaller the leaf **2**, the worse the management of speed, acceleration and anticipation in terms of eco-driving.

DRIVING ADVICE, ECO-DRIVING

If your driving behaviour is deemed un-economic (small orange leaf), you may be provided with advice.

If you regularly monitor this indicator you will be able to reduce your vehicle's fuel consumption.

On the multimedia screen 4

Journey record

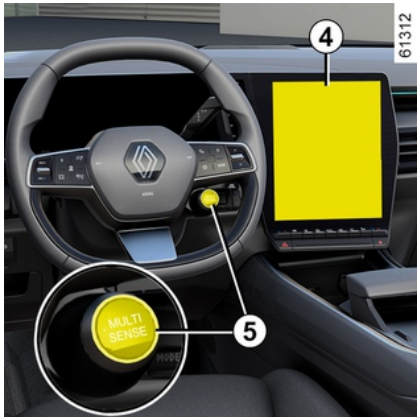

When the engine is switched off, a notification appears on the multimedia screen 4 to provide information on your driving during your last trip.

This notification provides direct access to the "ECO driving" menu. This menu provides more information on your dri-

ving and its effect on your fuel consumption.

Please refer to the multimedia instructions for further information.

ECO mode

ECO mode is a function which optimises fuel consumption. It affects the vehicle behaviour (acceleration, gear shifting, cruise control, deceleration, etc.).

Limiting acceleration enables low fuel consumption in urban and surrounding areas.

Activating the function

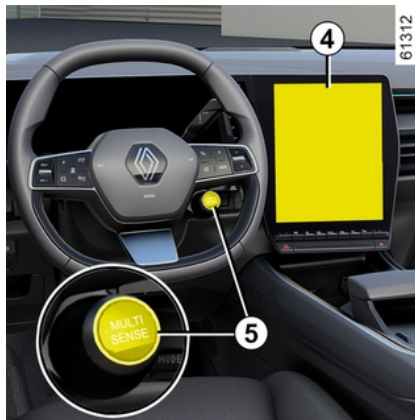

You can access ECO mode:

- from the multimedia screen 4;

- using the steering wheel control 5.



The "ECO" indicator light 6 is displayed on the instrument panel to confirm that it is activated.

To do this, press the accelerator pedal firmly and fully.

ECO mode is reactivated when you take pressure off the accelerator pedal.

Deactivating the function

To deactivate ECO mode, please see the multimedia user manual.

DRIVING ADVICE, ECO-DRIVING

Power meter

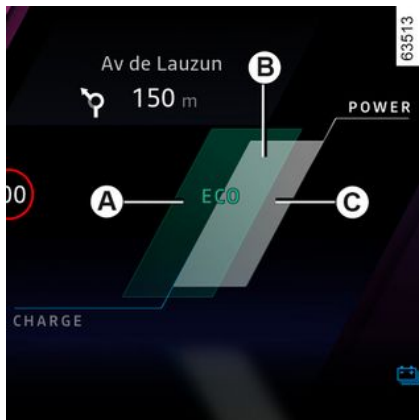

The charge meter gives you a real-time view of the energy consumed or recovered when the vehicle is moving.

"Energy recovery" A usage zone

When driving, if you lift your foot off the accelerator pedal or apply the brake, the motor generates electrical current during deceleration, and this energy is used to slow down the vehicle and recharge the traction battery.

"Optimal" B usage zone

Indicates economical driving, balanced between recovery and energy expenditure.

"Energy consumption" C usage area

In all-electric or hybrid mode, the traction battery and/or the combustion engine supply the energy required to move the vehicle.

Navigation system

Use the information available on your navigation system (traffic information etc.) to simplify your journey.

Driving advice, Eco-driving

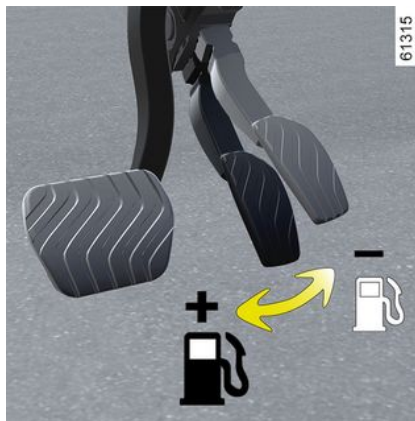

Behaviour

– Drive carefully until the engine reaches its normal operating temperature, rather than let it warm up while the vehicle is stationary.

– High speeds significantly affect the vehicle's fuel consumption.

Examples (at a steady speed):

- reducing the speed from approximately 80 mph (130 km/h) to 68 mph (110 km/h) saves up to around 20% of fuel;
- reducing the speed from approximately 56 mph (90 km/h) to 50 mph (80 km/h) saves up to around 10% of fuel.
- Dynamic driving with a lot of frequent acceleration and braking is expensive on fuel in comparison to the time saved.
- Do not over rev the engine in the intermediate gears. You should always use the highest gear possible.
- Avoid sudden acceleration.
- Brake as little as possible. If you anticipate an obstacle or bend in advance, you may then simply release the accelerator pedal.
- Do not try to maintain the same speed up a hill, accelerate no more than you would on level ground. Keep your foot in the same position on the accelerator pedal.
- Bad weather, flooded roads:



Do not drive through water if it is higher than the lower edge of the wheel rim.

Heating levels

DRIVING ADVICE, ECO-DRIVING

It is normal to notice an increase in the vehicle's fuel consumption when using the heating (particularly when the outside temperature drops below zero) or air conditioning.



Driver obstruction

On the driver's side, only use mats that are suitable for the vehicle, attach using the pre-fitted components, and check the fittings regularly. Do not lay one mat on top of another.

There is a risk of wedging the pedals

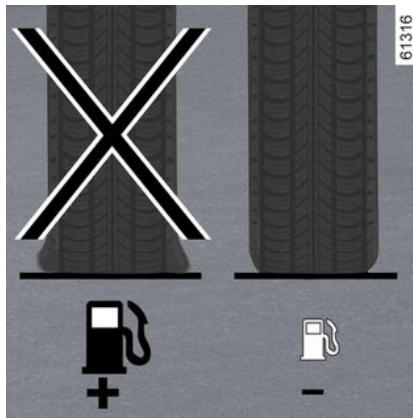

Tyres

- An underinflated tyre increases fuel consumption.
- To optimise fuel consumption, set the highest speed tyre pressure or the recommended pressure indicated on the edge of the driver's door → **346**.
- The use of non-recommended tyres can increase fuel consumption.



Advice on use

- Opt for ECO mode where possible.
- Electricity is fuel – switch off all the electrical components when they are not genuinely needed. **However** (safety first), keep your lights on when the visibility is bad ("see and be seen").
- Use the air vents. Driving with the windows open at 62 mph (100 km/h) will increase fuel consumption by 4%.
- Never fill the fuel tank right to the brim to avoid overflow.
- **On vehicles equipped with non-automatic air conditioning**, switch off the air conditioning when it is not required.

DRIVING ADVICE, ECO-DRIVING

Advice for reducing consumption and helping to preserve the environment:

If the vehicle has been parked in the sun, open the doors for a few moments to let the hot air escape before starting the engine.

- Do not leave an empty roof rack fitted to the vehicle.
- It is better to fit a trailer for bulky objects.
- When towing a caravan, fit a wind deflector and adjust it carefully.
- Avoid using the vehicle for "door-to-door" calls (short journeys with long waits in between) because in such conditions the engine never reaches its optimal operating temperature.

3

TYRE PRESSURE LOSS WARNING

61319

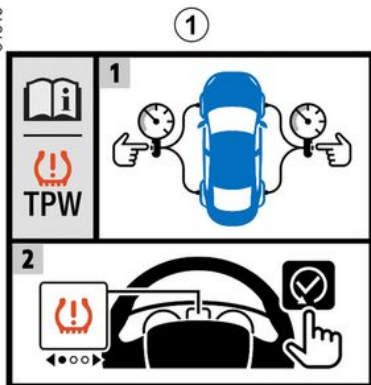

When fitted to the vehicle, this system notifies the driver if one or more tyres lose pressure.



61320

The system can be identified by the 1 label in the vehicle.

Operating principle



This system detects a loss of pressure in one of the tyres by measuring the wheel speed while driving.

The warning light 2  comes on and stays on to alert the driver in the event of insufficient pressure (deflated or punctured wheel).



This function is an additional driving aid.

The function does not take the place of the driver. It cannot, therefore, under any circumstances replace the vigilance or the responsibility of the driver. Check the tyre pressures, including the emergency spare wheel, once a month.

Operating conditions

In order to provide a reliable warning in the event of pressure loss, the system must be reset with an inflation pressure equal to one of those shown on the tyre inflation pressure label (reference values) → 346.

Resetting should always be carried out after checking the tyre pressure of all four tyres when cold.

In the following situations, the system risk coming into action late or not functioning correctly:

- system not reset after reinflation or any operation on the wheels;
- incorrectly reset system: tyre pressures different from the recommended pressures;

TYRE PRESSURE LOSS WARNING

- significant change in load or distribution of load on one side of the vehicle;
- sporty driving with strong acceleration;
- driving on snowy or slippery surface;
- driving with snow chains;
- fitting a single new tyre;
- use of tyres not approved by the network.



The tyre pressure must be checked before starting the resetting procedure. The system will not issue a warning if the pressure does not correspond to the recommended pressure.



The sudden loss of pressure in a tyre (burst tyre, etc.) cannot be immediately detected by the system.

Procedure for resetting the standard levels for the tyre pressures

This should be performed:

- after each re-inflation or resetting of tyre pressure;
- after changing a wheel;

- after changing wheels around.

Tyre pressures must correspond to the current usage of the vehicle (empty, carrying a load, motorway driving, etc.). Respect the tyre pressures (including the emergency spare wheel). Check them at least once a month and before every long journey (refer to the label on the edge of the driver's door → 346).

Resetting procedure via the multimedia screen 3



The resetting procedure must be carried out while the vehicle is stationary and the ignition is switched on. Please refer to the multimedia instructions for further information.



For your safety, the warning light **STOP** requires you to stop immediately as soon as traffic conditions allow.

Readjustment of tyre pressures

The pressure of the four tyres must be set when cold (refer to the label located on the edge of the driver's door).

If tyre pressures cannot be checked when the tyres are **cold, the recommended pressures should be increased by 0.2 to 0.3 bar (3 PSI)**.

Never deflate a hot tyre.

After each reinflation or readjustment of the tyre pressure, launch the resetting of the tyre pressure reference value.

Replacing wheels/tyres

Only use equipment approved by the brand network, otherwise there is risk of the system being activated late or not working correctly → 344.

After each change of wheel/tyre, readjust the tyre pressure and launch the reset of the tyre pressure reference value.

TYRE PRESSURE LOSS WARNING

Emergency spare wheel

If fitted on the vehicle, readjust the tyre pressure and launch the resetting of the tyre pressure reference value.

Tyre repair product and inflation kit

Only use equipment approved by the brand network, otherwise there is risk of the system being activated late or not working correctly → **347**. After using the tyre inflation kit, readjust the tyre pressure and launch the resetting of the tyre pressure reference value.

Tyre pressure faults







The table lists the warning messages which appear on the instrument panel **4** when the system detects a tyre pressure fault.

TYRE PRESSURE LOSS WARNING

Fault message table

The information on the instrument panel signals any potential tyre pressure faults (e.g. deflated or punctured tyre).

Indicator lights	Messages	Readings
 comes on	Inflate tyres and init.	This indicates that tyre under-inflation or puncture has been detected. Check and adjust the pressure of the four tyres when cold and reset the system.
 flashes, then stays on	Check tyre press and init.	This indicates that the reset has been unsuccessful. Check and readjust the tyre pressure before re-launching the resetting procedure.
 flashes, then stays on, along with the warning light 	Check TPW	This indicates a fault in the system. Consult an approved dealer.
 flashes, then stays on	TPW not available	This indicates that an emergency spare wheel different in size to the other four wheels has been fitted to the vehicle. The system remains unavailable until a wheel identical in size to the other wheels has been fitted and the resetting procedure has been carried out.

DRIVER CORRECTION DEVICES AND AIDS

Depending on the vehicle, they may include:

- the anti-lock braking system (ABS);
- the electronic stability control (ESC) with understeer control and traction control;
- emergency brake assist;
- driver assistance with a trailer;
- hill start assistance;
- the Hill Descent Control (HDC);
- the rear wheel steering;
- chassis control;
- multi-collision braking;
- regenerative braking system.



These functions are an additional aid in the event of critical driving conditions, enabling the vehicle behaviour to be adapted to suit the driving conditions. These functions do not take the place of the driver. **They do not increase the vehicle's limits and should not encourage you to drive more quickly.** Therefore, they can under no circumstances replace the vigilance or responsibility of the driver when manoeuvring the vehicle (the driver must always be ready for sudden incidents which may occur when driving).

Anti-lock braking system (ABS)

During intensive braking, the ABS prevents the wheels from locking, allowing the stopping distance to be managed and keeping control of the vehicle.

Under these circumstances, the vehicle can be steered to avoid an obstacle whilst braking. In addition, this system can increase stopping distances, particularly on roads with low surface grip (wet ground etc.).



You will feel a pulsation through the brake pedal each time the system is activated. The front passenger ABS does not in any way improve the vehicle's physical performance relating to the road surface and road-holding. It is still **essential** to follow the rules of good driving practice (such as driving at a safe distance from the vehicle in front etc.).



In an emergency, apply **firm and continuous pressure** to the brake pedal.

There is no need to pump it repeatedly. The front passenger-ABS will modulate the force applied in the braking system.

Operating faults:

–  and  light up on the instrument panel, accompanied by the "Check ABS", "Check braking system" and "Check ESC" messages to indicate that the ABS, the ESC and Emergency Braking Assist are deactivated. **Braking is still provided;**

–  ,  ,  and

 light up on the instrument

DRIVER CORRECTION DEVICES AND AIDS

panel, accompanied by the "Braking system fault" message **to indicate a fault in the braking system.**

In both cases, please consult an Authorised Dealer.

3



Your braking systems are partially operational. However, **it is dangerous to brake suddenly** and it is essential to stop immediately, as soon as traffic conditions allow. Call an approved Dealer.

Electronic stability control (ESC) with understeer control and traction control

Electronic stability program ESC

This system helps you to keep control of the vehicle in critical driving conditions (avoiding an obstacle, loss of grip on a bend, etc.).

Operating principle

A sensor in the steering wheel detects the direction selected by the driver.

Other sensors throughout the vehicle measure the actual direction.

The system compares driver input to the actual trajectory of the vehicle and

corrects the trajectory if necessary by controlling the braking of certain wheels and/or engine power. In the event that the system is triggered, the



warning light flashes on the instrument panel.

Understeer control

This system optimises the action of the ESC in the case of pronounced understeering (loss of front axle road holding).

Traction control

This system helps to limit wheelspin of the drive wheels and to control the vehicle when pulling away accelerating or decelerating.

Operating principle

Using the wheel sensors, the system measures and compares the speed of the drive wheels at all times and slows down their over-rotation. If a wheel is starting to slip, the system brakes automatically until the drive supplied becomes compatible with the level of grip under the wheel again.

The system also adjusts the engine speed to the grip available under the wheels, independently of the pressure exerted on the accelerator pedal.

In some situations (driving on very soft ground such as snow or mud, or driving with snow chains fitted), the system may reduce the engine power to limit wheelspin.

Operating faults

When the system detects an operating fault, the "Check ESC" message and



the warning lights appear on the instrument panel. In this case, the ESC and traction control system are deactivated.

Consult an approved dealer.

Activating, inhibiting the traction control function



DRIVER CORRECTION DEVICES AND AIDS

In some situations (driving on very soft ground such as snow or mud, or driving with snow chains fitted), the system may reduce the engine power to limit wheelspin. Activate the function by pressing the switch **1**. If this is not required, it is possible to deactivate the function by pressing switch **1**. In this

case, the  warning light appears on the instrument panel accompanied by the "ESC OFF" message.

The traction control system offers additional safety. It is recommended that you do not drive with the function disabled. Get out of this situation as soon as possible by pressing the switch **1** again.

Emergency brake assist

This system is complementary to the ABS which helps to reduce vehicle stopping distances.

Operating principle

The system is for detecting an emergency braking situation. In this case, the braking system immediately develops maximum power and may trigger the ABS.

The ABS braking is maintained as long as the brake pedal is pressed.

Brake lights come on

Depending on the vehicle, these may flash in the event of sudden deceleration.

Braking anticipation

Depending on the vehicle, when you rapidly release the accelerator, the system anticipates the braking manoeuvre in order to reduce stopping distances.

Special cases

When using the cruise control:

- if you use the accelerator pedal when you release it, the system may be triggered;
- if you do not use the accelerator, the system will not be triggered.

Operating faults

When the system detects an operating fault, the "Check braking system" message is displayed on the instrument panel accompanied by the warning

light .

Consult an approved dealer.



These functions are an additional aid in the event of critical driving conditions, enabling the vehicle behaviour to be adapted to suit the driving conditions. These functions do not take the place of the driver. **They do not increase the vehicle's limits and should not encourage you to drive more quickly.** Therefore, they can under no circumstances replace the vigilance or responsibility of the driver when manoeuvring the vehicle (the driver must always be ready for sudden incidents which may occur when driving).

Driver assistance with a trailer

This system helps to maintain control over the vehicle while using a trailer. It detects shaking caused by towing a trailer under certain driving conditions.

Operating conditions

- The function must be activated by an approved dealer;
- the towbar must be authorised by an approved dealer;

DRIVER CORRECTION DEVICES AND AIDS

- the wiring must be authorised by an approved dealer;
- the towbar must be connected to the vehicle.

Operating principle

The function stabilises the vehicle by:

- asymmetric braking of the front wheels to reduce shaking caused by the trailer;
- braking of all four wheels and limitation on engine torque to reduce the vehicle speed until the shaking has stopped.

Warning light  flashes on the instrument panel to inform the driver.



If the towbar wiring is plugged in but no trailer is attached (bicycle carrier, luggage carrier with lighting, etc.), the function may act under certain rutted road conditions.

Risk of vehicle deceleration.

Hill start assistance

Depending on the gradient of the incline, this system assists the driver when starting on a hill. It prevents the

vehicle from rolling backwards by automatically applying the brakes when the driver lifts his/her foot off the brake pedal to depress the accelerator pedal.

System operation

It operates only when the gear lever is in a non-neutral position (position other than N or P on an automatic gearbox) and the vehicle is completely stationary (brake pedal pressed).

The system holds the vehicle for approximately **2 seconds**. The brakes are then gradually released (the vehicle will move according to the slope).



The hill start assistance system cannot completely prevent the vehicle from rolling backwards in

all situations (extremely steep gradients etc.).

In all cases, the driver may depress the brake pedal to prevent the vehicle from rolling backwards.

The Hill Start Assist function should not be used for prolonged stops: use the brake pedal.

This function is not designed to immobilise the vehicle permanently.

If necessary, use the brake pedal to stop the vehicle.

The driver must remain particularly vigilant when driving on slippery or low-grip surfaces.

Risk of serious injury.

Hill descent control (HDC)

(depending on the vehicle)

This function enables the vehicle speed to be limited without depressing the brake pedal (when driving down a steep hill).

DRIVER CORRECTION DEVICES AND AIDS

Hill descent control operates between approximately 4 and 19 mph (6 and 30 km/h) in forward gear and at approximately 4 mph (6 km/h) in reverse gear.

Note: if the vehicle speed is above 37 mph (60 km/h), the system is deacti-

vated and the  warning light goes out.

Activating/deactivating the system

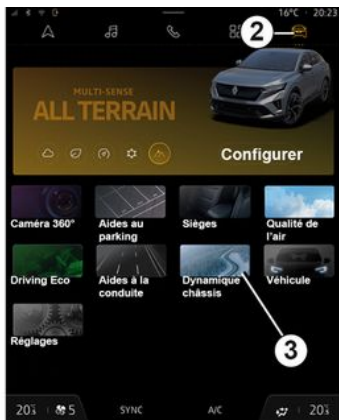

There are several activation methods available to access the system:

- via the "Hill Descent Control" widget (if configured by the customer);
- via the "Favourites" function (if configured by the customer) → 130;
- depending on the vehicle, from the "Vehicle" world 2, select "Chassis dynamics" 3, then press 4. the 

warning light is displayed on the instrument panel. To deactivate the function, press 4 again. The warning light

 goes out on the instrument panel.

Starting the system

With the vehicle moving downhill, as soon as sufficient gradient is detected,

the  warning light turns to green.

During activation of the hill descent control system, the descent speed can be increased using the accelerator pedal or decreased using the brake pedal.

Each time the system is activated, you may hear the noise of the braking assistance pump as it operates.

Note: this system does not function as the gear lever is in **P** position or if the vehicle is driving on a flat surface.

Operating faults

In the event of an operating fault, the "Check HDC" message is displayed in orange on the instrument panel.

If there is an operating fault, contact an approved dealer.

If the system is unavailable, the "HDC unavailable" message is displayed on the instrument panel.

DRIVER CORRECTION DEVICES AND AIDS

3



The hill descent control system may deactivate itself temporarily if there is a risk of the braking system temperature increasing

(the  warning light goes out).

If necessary, use the brake pedal to stop the vehicle.

The driver must remain particularly vigilant when driving on slippery or low-grip surfaces and/or on hills.

Risk of serious injury.

Rear wheel steering

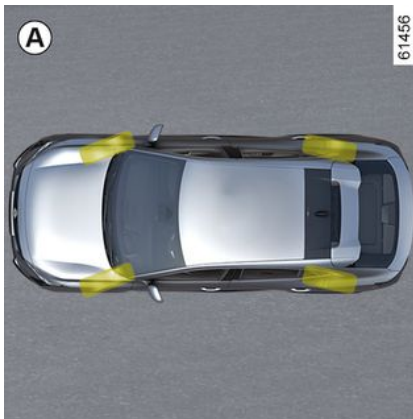

For vehicles which are fitted with it, this system, when the vehicle is being driven, directs the rear wheels according to the driving conditions: at low speed this system favours manoeuvrability, at higher speeds it optimises stability.

When driving at low speeds, the rear wheels steer in the opposite direction to the front wheels (Figure **A**) to improve the vehicle's manoeuvrability. This is used when driving in towns, on winding roads, during parking manoeuvres, etc.

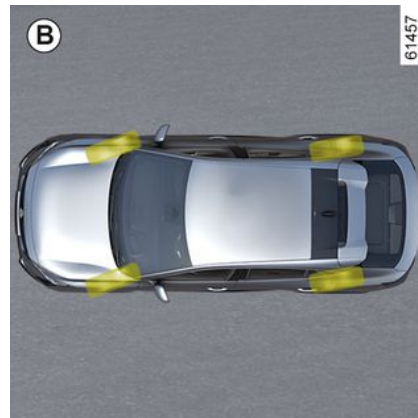

When driving at higher speeds, the rear wheels steer in the same direction as the front wheels (Figure **B**) to optimise the vehicle's stability. This is useful when changing lanes or when cornering etc.

Note: the system configuration (responsiveness etc.) depends on the mode selected in the "MULTI-SENSE » → 301" menu.

Operating faults

– If the  warning light is displayed on the instrument panel, accompanied by the "Check steering" warning light, consult an authorised dealer immediately.

DRIVER CORRECTION DEVICES AND AIDS

- If the **STOP** warning light is displayed on the instrument panel, accompanied by the "Steering fault" message, **this indicates a system fault.**



STOP requires you to stop as soon as traffic conditions allow. Call an approved dealer.

An impact to the underside of the vehicle (e.g. striking a post, raised kerb or other street furniture) may result in damage to the vehicle (e.g.: deformation of an axle). To avoid any risk of accident, have your vehicle checked by an approved dealer.

Chassis control

The "Chassis control" system allows the rigidity of the suspension (variable suspension) to be adapted according to the driving conditions.

Depending on the setting and the MULTI-SENSE mode selected → **301** the system changes from a more supple suspension (Comfort) to a more rigid suspension (Sport).

Three operating modes are available:

- Comfort;
- Dynamic;
- Sport.



If the visibility is sufficient, the camera **1** detects upcoming obstacles to enable the system to anticipate and adapt the adjustments required to maintain good road holding.

Note: make sure the windscreen is not obscured (dirt, mud, snow, condensation etc.).

Multi-collision braking

Multi-collision braking reduces the risk of an additional collision after an accident by temporarily bringing your vehicle to a standstill.

Operating principle

When the airbag system detects a collision, the pretensioners or airbags are triggered → **85** and the "Multi-collision braking" function activates the Electronic Stability Program (ESC) to brake the vehicle.

Multi-collision braking is deactivated during operation if:

- the driver presses the accelerator pedal firmly;

and/or

- the braking force generated by the driver pressing the brake pedal is greater than the force produced by the automatic braking triggered by the function.

Note: multi-collision braking requires the proper functioning of your vehicle's braking system.

Operating faults

When the system detects an operating fault, the "Check Post-collision" mes-

sage and the warning light  are displayed on the instrument panel.

In this case, the function is deactivated. Consult an approved dealer.

DRIVER CORRECTION DEVICES AND AIDS

Regenerative braking system

When braking, the regenerative braking system can convert the energy produced by the vehicle deceleration into electric energy.

This will recharge the traction battery and extend the vehicle range.

Operating faults

–  lights up on the instrument panel, accompanied by the "Check braking system" message: **braking assistance is still operational.**

Under these conditions, the feel of applying the brake pedal may be different.

You are recommended to apply strong continuous pressure to the pedal.

Please see an authorised dealer.

–  lights up on the instrument panel, accompanied by the "Braking system fault" message: **this indicates a fault in the braking system.**

Please call an authorised dealer.



The warning light

 for your own safety, it requires you to stop immediately as soon as traffic conditions allow. Switch off the engine and do not restart it. Call an approved Dealer.

ADDITIONAL DRIVING AID FUNCTIONS

My Safety

The "My Safety" function can be used to deactivate or activate a set of driver assistance functions simultaneously.

Depending on the vehicle, you can configure the "My Safety" function from the multimedia screen by selecting the driving aid functions to be switched off as a group.

Operation



"All ON" mode

Depending on the vehicle, the functions and configurations of driving assistance concerned are:

- overspeed sound alert → 229;
- lane departure prevention → 196;
- driver vigilance warning → 227;
- emergency lane departure prevention → 203.

When the "All ON" mode is activated: the indicator light on the button **1** lights up and the "My Safety All ON selected" message is displayed on the instrument panel to confirm this. The driving aids that are available in the mode are activated.

"Custom" mode

You can use this mode to **deactivate** or **reactivate** certain driving aids that are available in the "All ON" mode previously configured using the "MY SAFETY PERSO" setting.

With the ignition on, press the switch **1** twice in quick succession. On the first press, the "Press again for My Safety Custom" message is displayed on the instrument panel. On the second press, the warning light on the switch **1** goes out. The "Custom" mode is activated. The "My Safety Perso selected" message is displayed on the instrument panel.

To switch back to "All ON" mode, **press once** on the button **1**. The indicator light on the button **1** lights up.



Depending on the length of time following the last time the engine was stopped, the alerts are reactivated:

- when the vehicle is unlocked;
- or
- when a door is opened;
- or
- when the engine is restarted.

Perso mode configuration

From the multimedia screen 2



ADDITIONAL DRIVING AID FUNCTIONS

Please refer to the multimedia instructions for more information.

Lane departure prevention



Using information from the **1** camera, the function triggers corrective action on the vehicle steering system when a continuous or broken line is crossed or when approaching the roadside (divider, barrier, pavement, embankment, etc.) without activating the direction indicator lights.

Depending on the setting, in the event of crossing a broken line without activating the direction indicator lights, the function:

- warns the driver without corrective action on the steering system;

or

- performs corrective action on the steering system.



You can **retake control of the vehicle** at any time by operating the steering wheel.

Location of the camera **1**

Make sure the windscreen is not obscured (by dirt, mud, snow, condensation etc.).



This function is an additional driving aid. This function is not under any circumstances intended to replace the due care and attention of the driver, who should at all times be in control of the vehicle.

Activation/deactivation

From the multimedia screen **2**





Please refer to the multimedia instructions for more information.

ADDITIONAL DRIVING AID FUNCTIONS

Using the switch "My Safety" 3



– **To deactivate the function**, if this has been deactivated from the Custom mode of the "My Safety" → 195 function, press twice on the switch 3. The  warning light is displayed in yellow on the instrument panel.

– **To reactivate the function**, press the 3 switch once. Warning light  comes on the instrument panel.

Operation



When the function is activated, the

 and the left-hand and right-hand line indicators 4 are displayed in grey on the instrument panel.

The function is ready to alert or intervene if the speed is above approximately 40 mph (65 km/h) and if the

 warning light and the left-hand or right-hand line indicators 5 appear in white.

The function is in operation if the vehicle

– approaches a roadside without activating direction indicators;

– crosses a continuous line without activating the indicator lights;

– crosses a broken line without activating the direction indicators, if the "operation on broken line" setting is selected.

In these cases:

– the function triggers an action on the vehicle's steering system to correct the vehicle trajectory;

– the  warning light and the indicator 4 on the side of the breached line changes to yellow on the instrument panel.

If the corrective action on the steering

system is not sufficient, the 

warning light and the indicator 4 on the side of the breached line change to red on the instrument panel, accompanied by a vibration on the steering wheel.

When the "Operation on broken line" setting is not selected, **the function sounds the alarm** if the vehicle crosses a broken line without activating the indicator lights, and there is no roadside close enough to the line.

In this case, the function warns the driver:

– by a vibration in the steering wheel; and

ADDITIONAL DRIVING AID FUNCTIONS

– the  warning light and the indicator 4 on the side of the breached line turns to red on the instrument panel.

Note: on bends, the function allows for slightly cutting the bend.

Special cases

"Keep control" Warning

– If the system is operating and does not detect any activity on the steering wheel, the "Keep control" message appears on the instrument panel accompanied by a beep and, depending on

the vehicle, the  warning light appears in yellow until the driver has regained control of the vehicle.

– If the system has been in operation for too long, the "Keep control" message appears on the instrument panel accompanied by a beep and depend-

ing on the vehicle, the  warning light appears in yellow accompanied by the indicator 4 on the side of the line concerned until the driver has regained control of the vehicle.



You can interrupt the trajectory correction at any time by moving the steering wheel.

Vehicle fitted with "Active driver assist"

If the "Lane centring" function is activated at the same time as the "Lane departure prevention" function, the display of the warning light will vary as follows:

– the "Lane Centring" function is in operation: the green  warning light

replaces the white or grey  warning light on the instrument panel. Thus, you are informed as a priority of the status of the function "Channel centring";

– the "Lane Centring" function is put on standby and the "Lane Departure Prevention" function is neither ready

nor in operation: the grey  warning light replaces the white or grey

 warning light on the instrument panel. Thus, you are informed as a priority of the status of the function "Channel centring";

– the "Lane Centring" function is put on standby while the "Lane Departure Prevention" function is ready or in op-

eration: the  warning light is displayed in red or in yellow on the instrument panel. Thus, you are informed as a priority of the status of the function "Lane departure prevention".

In any case, you are informed at all times of the status of the function when it controls the steering system of your vehicle. The most useful information is always displayed.

Function temporarily unavailable/disabled

- very fast lane departure;
- driving continuously on a line;
- approximately four seconds after changing lanes;
- tight bends;
- impaired visibility;
- one of the direction indicators is activated;
- activating the hazard warning lights;
- engaging reverse gear;
- strong acceleration;
- the vehicle speed is over approximately 112 mph (180 km/h);
- the lane width changes;
- operation of the Electronic Stability Control system;

ADDITIONAL DRIVING AID FUNCTIONS

- operation of the anti-lock braking system;
- the active emergency braking system is triggered;
- intervention of another function that controls the steering system, such as the "Lane Centring" function.

If the function is unavailable, the  warning light and left-hand and right-hand correction indicators **4** change to grey on the instrument panel.

When the front camera is obscured, the "Front camera no visibility" message appears on the instrument panel. Clean the area where the sensors are located

Automatic deactivation

The function is automatically deactivated when:

- The vehicle dynamics control system is deactivated;
 - The electronic stability system is malfunctioning;
 - The anti-lock braking system is malfunctioning;
 - a towbar is electrically connected to the trailer hitch socket;
- warning light  is displayed.

When the function is deactivated, the warning light  is displayed in yellow on the instrument panel.

Settings



To access the multimedia screen function settings **2**, refer to the multimedia instructions:

- "Operation on broken line": use this setting to select the response of the function if the vehicle crosses a broken line without activating the direction indicators:
 - selected setting: the function may trigger an action on the vehicle's steering system to correct the vehicle trajectory;

- setting not selected: the function can warn the driver by means of a vibration at the steering wheel without correcting the vehicle trajectory.
- "Vibration": adjust the steering wheel vibration for the "Lane departure prevention" function;
- "Lane exit anticipation": adjust the line detection sensitivity level. To do this, select:
 - "Late": line detected upon crossing;
 - "Standard": line detected on approach;
 - "Early" line detected nearby.

Please refer to the multimedia instructions for further information.

Operating faults

When the system detects an operating fault, the left-hand and right-hand line

indicators and the warning light  are displayed in yellow on the instrument panel.

In some cases, they are accompanied by the following message:

- «Driving assist unavailable» ;
- or
- «Check Front camera» ;
- or
- «Check Driving assist».

ADDITIONAL DRIVING AID FUNCTIONS

Consult an approved dealer.

3

ADDITIONAL DRIVING AID FUNCTIONS

Warnings



This function is an additional driving aid. This function is not under any circumstances intended to replace the due care and attention of the driver, who should at all times be in control of the vehicle.

System servicing/repairs

- In the event of an impact, the camera alignment may be changed, and its operation may consequently be affected. Deactivate the function and consult an authorised dealer.
- Any work in the area where the camera is located (repairs, replacements, windscreen modifications etc.) must be carried out by a qualified professional.

Only an authorised dealer is qualified to service the system.

In the event of system disturbance

Some conditions can disturb or damage the system's operation, such as:

- windscreen obscured (by dirt, ice, snow, condensation etc.);
- a complex environment (tunnel, etc.);
- poor weather conditions (snow, rain, hail, black ice, etc.);
- poor visibility (night, fog, etc.);
- the road markings are irregular or difficult to distinguish (e.g. partially erased, excessive spacing, uneven road surface, etc.);
- being dazzled (glaring sun, lights of vehicles travelling in the opposite direction; etc.);
- the road is narrow, winding or undulating (tight bends, etc.);
- closely following a vehicle travelling in the same lane.

In this case, the "Lane departure prevention" function may be activated incorrectly or not at all.

Risk of unwanted, incorrect correction or no correction of trajectory.

Deactivating the function

You must deactivate the function if:

- the area of the camera has been damaged (on the windscreen side or the interior rear-view mirror side);
- the road is slippery (snow, black ice, aquaplaning, gravel etc.);
- poor visibility (night, fog, etc.);

ADDITIONAL DRIVING AID FUNCTIONS

- the windscreen is cracked or distorted (do not carry out windscreen repairs in this area; have it changed by an approved dealer);
- the vehicle is towing a trailer or a caravan;
- the vehicle is entering an area with several surface markings (an area with road works etc.).

3

ADDITIONAL DRIVING AID FUNCTIONS

Emergency lane departure prevention



Using information from the radar **2** and the camera **1**, the function triggers corrective action on the vehicle steering system in the event of a risk of collision with a vehicle coming from the opposite direction in the adjacent lane, without the direction indicator having been activated.

Depending on the vehicle, using information from the radars **3** and the camera **1**, the function triggers corrective action on the vehicle steering system.

In the event of a risk of collision with a vehicle moving at the same speed or a higher speed, located in the detection area of the rear radars (emergency lane departure prevention in case of overtaking).

 You can **retake control of the vehicle** at any time by operating the steering wheel.



This system provides an additional driving aid. This system is not, under any circumstances, intended to replace the due care and attention of the driver, who should at all times be in control of the vehicle.

Location of the camera **1**

Make sure the windscreen is not obscured (by dirt, mud, snow, condensation etc.).

Location of the front radar **2**

Ensure that the radar area is not obstructed (dirt, mud, snow, a badly fitted/attached front number plate), impacted, modified (including paintwork) or hidden by any accessory fitted on the front of the vehicle (on the front bumper, logo, etc.)

Location of the side radars **3**

Ensure that the radar area is not obstructed (by dirt, mud, snow etc.), impacted or modified (including paintwork etc.).

ADDITIONAL DRIVING AID FUNCTIONS

Activating/deactivating the function

From the **A** "My Safety" switch



Press switch **A** twice if the function has been deactivated via the Custom mode of the "My Safety" function
➔ 195.

To reactivate the function, press the **A** switch.

From the B multimedia screen

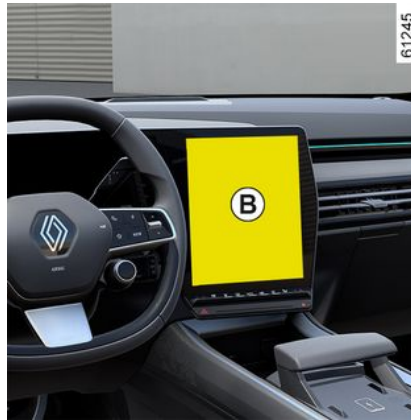

Please refer to the multimedia instructions for more information.

Detection of an oncoming vehicle

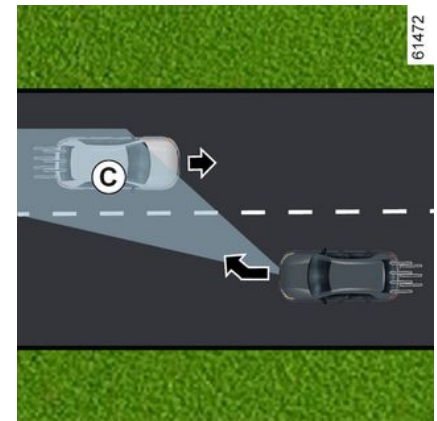
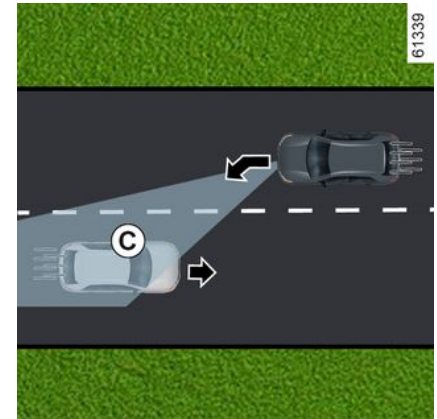

ADDITIONAL DRIVING AID FUNCTIONS

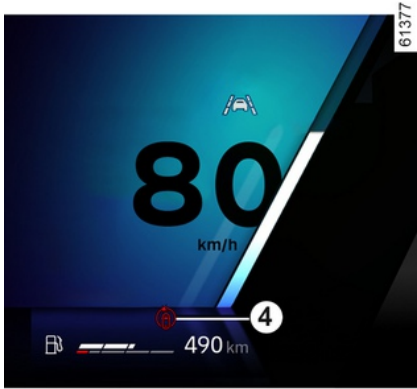

When driving at a speed between approximately 40 mph (65 km/h) and 68 mph (110 km/h), if there is a risk of col-

lision with a vehicle coming from the opposite direction in an adjacent lane and within the detection zone **C**, without the direction indicator having been activated, the system:

– **warns you of a collision risk:**

The message "Risk of collision" is displayed on the dashboard accompanied by the indicator **4** in red, the line on the side of the intervention and an audible signal. Display **5** appears on the instrument panel on the side of the intervention;

and

– **triggers corrective action on the steering system.**



You can interrupt the trajectory correction at any time by moving the steering wheel.



This function is an additional driving aid.

This function is not under any circumstances intended to replace the due care and attention of the driver, who should at all times be in control of the vehicle.

The function may not activate if the approaching speed is greater than approximately 124 mph (200 km/h) (for example, you are travelling at 68 mph (110 km/h) and the vehicle is travelling in the opposite direction in the adjacent lane at 56 mph (91 km/h).

If case of overtaking

(depending on the vehicle)

ADDITIONAL DRIVING AID FUNCTIONS

3

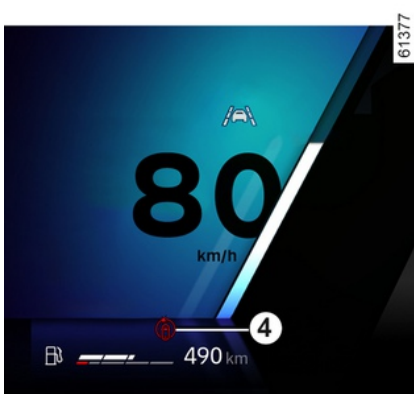
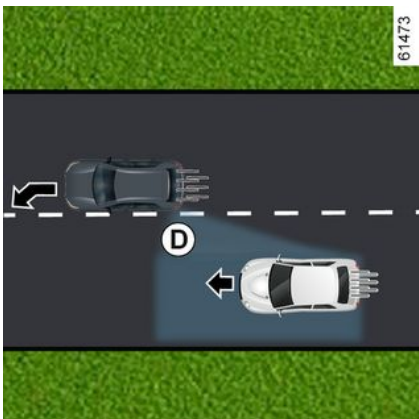
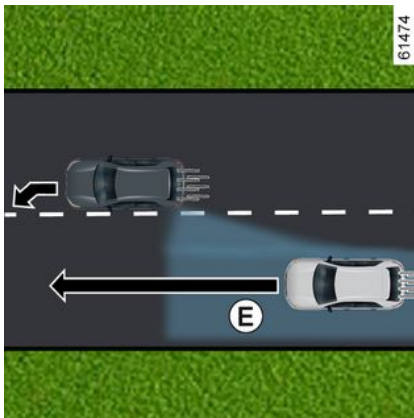

While driving at a speed over 40 mph (65 km/h), when approaching a line (continuous or broken) and there is a risk of collision with a vehicle located in the blind spot **D** and it is moving in the same direction as your vehicle or with a vehicle that is rapidly approaching from behind in an adjacent lane that is in the detection area **E**, the system:

- **warns you about a risk of collision:** the warning light **7** flashes, the message "Lateral obstacle detected" is displayed on the instrument panel, accompanied by the indicator **4** in red, the line on the side of the intervention and an audible signal. Display **5** appears on the instrument panel on the side of the intervention;

ADDITIONAL DRIVING AID FUNCTIONS

and

- **triggers corrective action on the steering system.**

Temporarily not available / non-activation of the system

The system is temporarily unavailable or disabled when:

- very fast lane departure;
- driving continuously on a line;
- approximately four seconds after changing lanes;
- tight bends;
- impaired visibility;
- activation of the direction indicator light (only when an oncoming vehicle is detected in an adjacent lane);
- activating the hazard warning lights;
- strong acceleration;
- the vehicle speed is over approximately 112 mph (180 km/h);
- the lane width changes;
- operation of the Electronic Stability Control system;
- operation of the anti-lock braking system;
- operation of the active emergency braking system;
- ...

The system cannot be activated when:

- the camera does not detect a line (solid or broken) on the relevant side;

- the camera does not simultaneously detect the two boundaries of the lane in which your vehicle is moving;
- reverse gear is engaged;
- the field of vision of the camera is obstructed;
- the front radar is obscured;
- depending on the vehicle, the rear radars are obscured;
- ...

Depending on the vehicle, if one of the side radars is obscured the message "Side radars no visibility" will appear on the instrument panel.

When the front radar is obscured, the "Front radar no visibility" message is displayed on the instrument panel.

When the front camera is obscured, the "Front camera no visibility" message is displayed on the instrument panel.

Clean the area where the sensors are located.

Automatically deactivating the function

The system is automatically deactivated when:

- The vehicle dynamics control system is deactivated;
- The electronic stability system is malfunctioning;

- The anti-lock braking system is malfunctioning;
- A towbar is electrically connected to the trailer hitch socket;
- the **STOP** warning light is displayed.

If the vehicle is equipped with a towbar that is recognised by the system, the message "Trailer: side radars unavailable" is displayed to inform you that the emergency lane departure prevention function has been deactivated.

If the vehicle is towing a trailer or caravan, unexpected or unnecessary corrections may occur. You can deactivate the system to avoid unexpected or unnecessary corrections.

Operating faults

When the function detects an operating fault, the following messages may be displayed on the instrument panel:

- « Check Front camera » ;
 - or
 - « Front radar to check » ;
 - or
 - « Check Driving assist » ;
 - or, depending on the vehicle,
 - « Check Side radars » .
- Consult an approved dealer.

ADDITIONAL DRIVING AID FUNCTIONS

Warnings



This function is an additional driving aid. This function is not under any circumstances intended to replace the due care and attention of the driver, who should at all times be in control of the vehicle.

System servicing/repairs

- In the event of an impact, the alignment of the camera or radar(s) may be altered and its operation may consequently be affected. Deactivate the function and consult an authorised dealer.
- Any work in the area where the camera or radars are located (replacements, repairs, windscreen modifications etc.) must be carried out by a qualified professional.

Only an authorised dealer is qualified to service the system.

In the event of system disturbance

Some conditions can disturb or damage the system's operation, such as:

- windscreen obscured (by dirt, ice, snow, condensation etc.);
- a complex environment (tunnel, etc.);
- poor weather conditions (snow, rain, hail, black ice, etc.);
- poor visibility (night, fog, etc.);
- the road markings are irregular or difficult to distinguish (e.g. partially erased, excessive spacing, distorted road surface...);
- being dazzled (glaring sun, lights of vehicles travelling in the opposite direction; etc.);
- the road is narrow, winding or undulating (tight bends, etc.);
- closely following a vehicle travelling in the same lane.

In this case, the "lane departure prevention" function may be activated incorrectly or not at all.

Risk of unwanted, incorrect correction or no correction of trajectory.

Deactivating the function

You must deactivate the function if:

- the camera area (on the windscreen side or the interior rear-view mirror side) or radar area(s) have been damaged;
- the road is slippery (snow, black ice, aquaplaning, gravel etc.) ;
- poor visibility (night, fog etc.) ;

ADDITIONAL DRIVING AID FUNCTIONS

- the windscreen is cracked or distorted (do not carry out windscreen repairs in this area; have it changed by an approved dealer);
- the vehicle is towing a trailer or a caravan;
- the vehicle is being towed (breakdowns);
- the vehicle is entering an area with several surface markings (an area with road works etc.) ;
- you are not driving on a paved road.

ADDITIONAL DRIVING AID FUNCTIONS

Blind spot warning

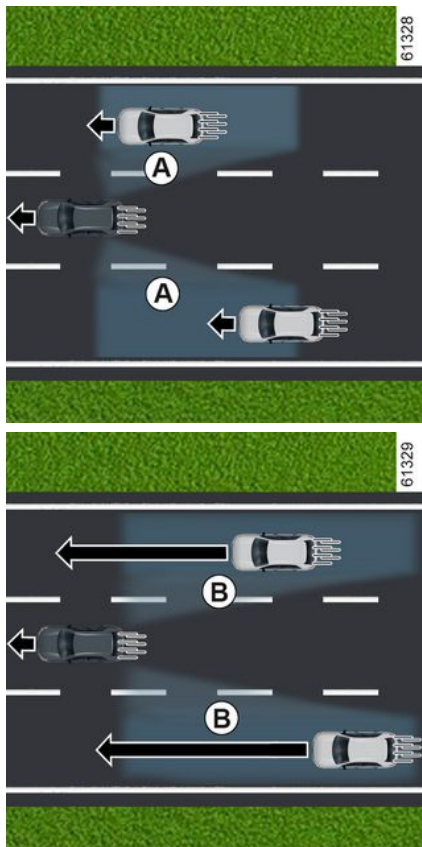

Using information from the sensors installed on each side of the rear bumper (area **C**), the function warns the driver:

- when a vehicle is in the blind spot area **A** and travelling in the same direction as your vehicle;
- and/or
- when there is a risk of collision with a vehicle that is in the **B** area and driving faster than you on an adjoining lane.

The function warns you when your vehicle is travelling at a speed above approximately 9 mph (15 km/h).



The function does not notify the driver if the other vehicles are not moving.



This function is an additional driving aid. This function is not under any circumstances intended to replace the due care and attention of the driver, who should at all times be in control of the vehicle.

Special feature



ADDITIONAL DRIVING AID FUNCTIONS

Ensure that zone **C** around the radars on each side of the rear bumper are not obstructed (by dirt, mud, snow, etc.).

If one of the radars is obscured, the "Side radars without visibility" message is displayed on the instrument panel. Clean the area where the sensors are located.

Warning light 2



A warning light **2** is located on each door mirror **3**.

Note:

– clean the **3** rear view mirrors regularly, so that the indicator lights **2** can be seen properly;

– if you overtake another vehicle, the warning light **2** will only come on, if that vehicle remains for a long enough period in your vehicle's blind spot area **A**.

Display **D**

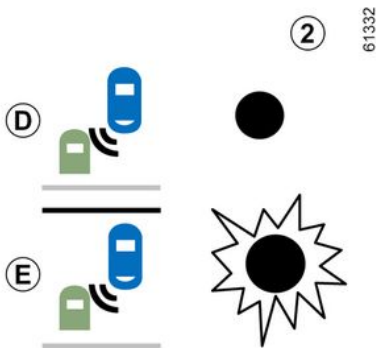

First warning: **direction indicator not activated**, the warning light **2** indicates that a vehicle is detected in the blind spot area and/or that a vehicle is rapidly approaching from the rear in an adjacent lane.

Display **E**

Direction indicator activated, the **2** warning light flashes when the function detects a vehicle in the blind spot

warning area and/or a vehicle is rapidly approaching from the rear on the side towards which you will turn the wheel.

If you cancel the direction indicator, the function will return to the initial warning (display **D**).

Conditions for non-function

- When driving on a road with tight bends;
- in reverse.

If the vehicle is equipped with a towbar recognised by the system, the "Trailer: blind spot warning off" message is displayed on the instrument panel to inform you that the function is not operational. For information on the range of equipment adapted to your vehicle, we advise you to consult an approved Dealer.

Operating faults

If the system detects a fault, the "Check Side radars" message is displayed on the instrument panel.

Consult an approved dealer.

ADDITIONAL DRIVING AID FUNCTIONS



Due to the presence of sensors behind the bumper, it is advisable to entrust any operation on the bumper (repair, replacement, paintwork, etc.) to a qualified professional.

3

ADDITIONAL DRIVING AID FUNCTIONS

Warnings



- The system's detection range operates according to a standard lane width. If driving on a narrow lane, the system may warn you when a vehicle is detected further away than the nearest lane.
- The system's detection range operates according to a standard lane width. If you are driving in wide traffic lanes, the system might not be able to detect a vehicle in the blind spot.
- In the event of very bad weather conditions (heavy rain, snow, etc.), the system may be temporarily disrupted. Remain aware of driving conditions.

There is a risk of accidents.

ADDITIONAL DRIVING AID FUNCTIONS



This function is an additional driving aid. This function is not under any circumstances intended to replace the due care and attention of the driver, who should at all times be in control of the vehicle.

The driver should always adapt their speed to the traffic conditions, regardless of the system indications.

The system should under no circumstances be taken to be an obstacle detector or an anti-collision system.

System servicing/repairs

- In the event of an impact, radar alignment may be changed, and its operation will consequently be affected. Consult an approved dealer.
- Any work in the area where the radars are located (repairs, replacements, etc.) must be carried out by a qualified professional.

Only an authorised dealer is qualified to service the system.

System disturbance

Some conditions can disturb or damage the system's operation, such as:

- complex surroundings (metal bridges, tunnels, roads with barriers at the edge, etc.);
- poor weather conditions (snow, hail, black ice etc.) ;
- the vehicle is fitted with a towbar that is not recognised by the system.

Risk of false alarms or absence of warnings

If the system behaves abnormally contact an authorised dealer.

ADDITIONAL DRIVING AID FUNCTIONS



Limitation of the system operation

- The radar area should be kept clean and free of any modifications in order to ensure the proper operation of the system.
- Small objects moving close to the vehicle (motorcycles, bicycles, pedestrians, etc.) may not be recognised by the system.
- When turning into a bend, the radars may temporarily cease to detect vehicles in adjacent lanes.
- The function may warn you late when two other vehicles are approaching from the rear, side by side in the adjacent lanes (driving on a 3-lane road) and at a much higher speed than your vehicle.
- The system may not provide a warning when the other vehicles are travelling at a significantly different speed.
- If the vehicle is being overtaken by a long vehicle (e.g. heavy goods vehicle overtaking at a similar speed to the vehicle) the system may interrupt the warning before the end of the manoeuvre.
- The vehicle is travelling on a winding road.

ADDITIONAL DRIVING AID FUNCTIONS

Safe distance alert



Using the information from the radar 2 and camera 1, this function informs the driver of the time interval between their vehicle and the vehicle in front so that a safe stopping distance between the two vehicles can be maintained.

The function is activated when the vehicle speed is between approximately 19 and 112 mph (30 and 180 km/h).

Location of the camera 1

Make sure the windscreen is not obscured (by dirt, mud, snow, condensation etc.).

Location of the radar 2

Ensure that the radar area is not obstructed (by dirt, mud, snow, a badly fitted front number plate etc.), impacted, modified (including painting) or hidden by any accessory fitted on the front of the vehicle (on the grille or logo etc.).



This function is an additional driving aid. This function is not under any circumstances intended to replace the due care and attention of the driver, who should at all times be in control of the vehicle.

Activation/deactivation from the multimedia screen 3



From the "Vehicle" world on your multimedia screen 3, press the "Driving aids" menu.

Activate or deactivate the "Safe distance" function.



Each time the vehicle is started, the function continues the mode saved the last time the engine was stopped.

ADDITIONAL DRIVING AID FUNCTIONS

Operation

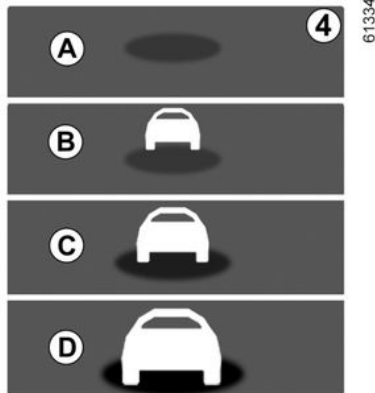

With the function activated, the **4** indicator is displayed on the instrument panel and informs the driver of the distance between their vehicle and the vehicle in front.

- **A** (grey): function not operational;
- **A** (green): no vehicle detected;
- **B** (green): the time interval is greater than or equal to around two seconds (distance between the two vehicles adapted to your speed);
- **C** (yellow): the time interval is between approximately 1 and 2 seconds (insufficient distance between the two vehicles);
- **D** (red): the time interval is less than or equal to around one second

(very insufficient distance between the two vehicles).

If the interval between the two vehicles is less than around 0.5 seconds, notification **B**, display **D**, will remain lit red on the instrument panel.

Under certain conditions, the time interval may not be displayed:

- while cornering;
- when changing lane;
- if the vehicle in front is sufficiently far or outside the range of the radar or camera.

ADDITIONAL DRIVING AID FUNCTIONS

Warnings



The measurement is displayed for information: the system does not carry out any action on the vehicle. This function is not designed for use in urban conditions or for a dynamic driving style (sudden cornering, acceleration, braking, etc.), but rather for stable driving conditions. The function does not interact with the braking system.

The radar and camera zones must be kept clean and free of any tampering in order to ensure the proper operation of the system.

Any work carried out in the area where the radar or camera is located (repairs, replacements, windscreen and/or bumper modifications, etc.) must be carried out by a qualified professional.

ADDITIONAL DRIVING AID FUNCTIONS



This function is an additional driving aid. This function is not under any circumstances intended to replace the due care and attention of the driver, who should at all times be in control of the vehicle.

System servicing/repairs

- In the event of an impact, the radar and/or camera alignment may be changed and its operation may consequently be affected. Deactivate the function and consult an authorised dealer.
- Any work carried out in the area where the radar and/or camera is located (replacements, repairs, windscreen and/or bumper modifications, etc.) must be carried out by a qualified professional.

Only an authorised dealer is qualified to service the system.

In the event of system disturbance

- obstruction of the windscreen or the bumper (by dirt, ice, snow, condensation etc.);
- a complex environment (metal bridge, tunnel, etc.);
- poor weather conditions (snow, hail, black ice, etc.);
- poor visibility (night, fog, etc.);
- poor contrast between the vehicle preceding it and the surrounding area (e.g. white vehicle in a snowy area, etc.);
- being dazzled (glaring sun, lights of vehicles travelling in the opposite direction; etc.);
- the road is narrow, winding and undulating (tight bends etc.)

Risk of erroneous false alarms.

ADDITIONAL DRIVING AID FUNCTIONS

Active emergency braking



Using information from the camera **1** and the radar **2**, the system determines the distance between your vehicle:

– from the vehicle ahead in the same lane;

or

– from any oncoming vehicles in the context of a manoeuvre to change direction;

or

– and vehicles passing perpendicularly;

or

– and stationary vehicles;

or

– surrounding pedestrians and cyclists.

The system informs the driver if there is a risk of head-on collision to enable appropriate emergency manoeuvres (pressing the brake pedal and/or turning the steering wheel).

Depending on the reactivity of the driver, the system can assist with braking in order to limit damage or prevent a collision.

The system is otherwise inactive and does not trigger an alert.



This function is an additional driving aid.

This function is not under any circumstances intended to replace the due care and attention of the driver, who should at all times be in control of the vehicle.



This system can apply maximum braking to the vehicle until it is completely stationary if necessary.

For safety reasons, always wear your seat belt when travelling in your vehicle and make sure that it is loaded so that no items can be thrown forward and hit the occupants.

Location of the camera **1**

Make sure the windscreen is not obscured (by dirt, mud, snow, condensation etc.).

Location of the radar **2**

Make sure that the area around the radar is not obscured (by dirt, mud, snow or an incorrectly fitted number plate), impacted, altered (including paintwork) or hidden.

Operation

When driving, when there is a risk of collision, the system:

– **alerts you of a collision risk:** the "Detected obstacle" message appears on the instrument panel accompanied by a beep.

ADDITIONAL DRIVING AID FUNCTIONS

Note: if the driver presses the brake pedal and the system still detects a risk of collision, the braking force may be increased if it is not sufficient to prevent the collision.

– **can trigger braking:** if the driver does not react to the alert and the collision becomes imminent, the red warn-

ing light  and the "Brake" message are displayed on the instrument panel accompanied by a sound signal.

Note:

– if the driver uses the vehicle controls (steering wheel, pedals, etc.) the system may delay its reaction or not activate;

– if active emergency braking has caused the vehicle to stop, the vehicle is kept stationary for a short time. Beyond this time limit, the driver must keep the vehicle stationary by holding their foot on the brake pedal;

– after the system activates braking, the "Advanced Safety triggered" message will be displayed



In the event of an emergency manoeuvre, you can stop the braking at any moment by:

- tapping the accelerator pedal;
- or
- turning the steering wheel as a collision avoidance manoeuvre.



Special features of warnings

Depending on the speed, the warning and braking may be activated simultaneously.

Vehicle detection

Detection of vehicles travelling in the same lane

A risk of a collision with the vehicle in front of you in the same lane is detectable by the system when the vehicle is travelling at a speed over approximately 5 mph (8 km/h).

Detection of oncoming vehicles in the context of a manoeuvre to change direction

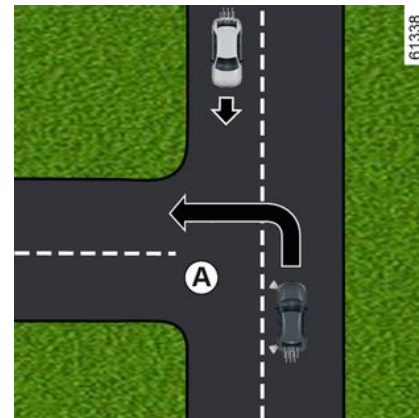

When you wish to change direction (e.g. **A**), oncoming vehicles are detected by the system when:

- your vehicle is travelling at a speed between approximately 5 mph (8 km/h) to 12 mph (20 km/h);
- you have activated the direction indicator light.

Detection of vehicles crossing the lane perpendicularly

Vehicles crossing the lane perpendicularly are detected by the system when:

- your vehicle is travelling at a speed between approximately 12 mph (20 km/h) and 37 mph (60 km/h).

Detection of vehicles stopped in the lane

ADDITIONAL DRIVING AID FUNCTIONS

Stationary vehicles are detected by the system when:

- your vehicle is travelling at a speed between approximately 5 mph (8 km/h) and 50 mph (80 km/h).

3 Detection of pedestrians and cyclists

Detection of pedestrians and cyclists in the same lane

The system detects pedestrians and cyclists when:

- your vehicle is travelling at a speed between approximately 5 mph (8 km/h) and 53 mph (85 km/h).

Detection of pedestrians and cyclists when changing direction

The system detects pedestrians and cyclists when:

- your vehicle is travelling at a speed between approximately 5 mph (8 km/h) and 12 mph (20 km/h).

Activation/deactivation

 Depending on the vehicle, according to the length of time following the last time the engine was stopped, the function is reactivated:

- when the vehicle is unlocked;
or
- when a door is opened;
or
- when the engine is restarted.

Activating, deactivating the system from the multimedia screen **3**



To activate or deactivate the function, refer to the multimedia instructions. Select "ON" or "OFF".

Settings



For safety reasons, carry out any adjustments while the vehicle is stationary.

Settings from the multimedia screen **3**

ADDITIONAL DRIVING AID FUNCTIONS



With the vehicle stationary, to access the function settings from the multimedia screen **3**, refer to the multimedia instructions:

"Warning anticipation": adjust the alert sensitivity level. To do this select:

- « Late » ;
- « Standard » ;
- « Early ».

Please refer to the multimedia instructions for more information.

Temporarily not available

If the system detects a temporary fault,

the  warning light appears on the instrument panel.

The possible causes are:

- the system is temporarily blinded (glare from the sun, dipped beam headlights, bad weather conditions etc.). The system will be operational again when visibility conditions are better;
- the system is temporarily interrupted (e.g. the windscreen, front or rear bumper or logo is obscured by dirt, mud, snow, condensation, etc.) In this case, park the vehicle and switch off the engine. Clean the windscreen, the front bumper or the logo. The next time the engine is started, after around five or ten minutes of driving, the warning light and the message disappear. If this is not the case, this may arise from another cause; contact an approved dealer.

Operating faults

If the system detects a temporary fault,

the  warning light appears on the instrument panel. Consult an approved dealer.

ADDITIONAL DRIVING AID FUNCTIONS

Warnings



This function is an additional driving aid. This function is not under any circumstances intended to replace the due care and attention of the driver, who should at all times be in control of the vehicle. The triggering of this function may be delayed or prevented when the system detects clear signs of control of the vehicle by the driver (action on the steering wheel, pedals etc.).

The system cannot be activated:

- the gear control is in Neutral position;
- when the Electronic Stability Program (ESC) has started.

System servicing/repairs

- In the event of an impact, the radar and/or camera alignment may be changed and its operation may consequently be affected. Deactivate the function and consult an authorised dealer.
 - Any work in the area where the radar and/or camera is located (repairs, replacements, windscreen modifications, etc.) must be carried out by a qualified professional.
- Only an authorised dealer is qualified to service the system.

ADDITIONAL DRIVING AID FUNCTIONS



System disturbance

Some conditions can disturb or damage the system's operation, such as:

- a complex environment (metal bridge, tunnel, etc.);
- poor weather conditions (snow, hail, black ice, etc.);
- poor visibility (night, fog, etc.);
- poor contrast between the object (vehicle, pedestrian etc.) and the surrounding area (e.g. pedestrian dressed in white located in a snowy area etc.);
- being dazzled (glaring sun, lights of vehicles travelling in the opposite direction; etc.);
- windscreen obscured (by dirt, ice, snow, condensation etc.);
- ...

In these conditions, the system may not react, may warn the driver or may brake inadvertently.

Limitation of the system operation

- Each time the vehicle is started, the system carries out a calibration according to the vehicle surroundings and may be inactive for approximately two to five minutes;
- The radar and camera areas must be kept clean and free of any modifications to ensure the proper functioning of the system if the conditions described in the "Special cases of oncoming vehicles when changing direction" are met;
- the system may not respond to small vehicles such as motorbikes as effectively as to other vehicles;
- the system may not operate properly when the road surface is slippery (rain, snow, black ice, etc.);
- to ensure correct operation, the system needs to distinguish the complete outline of the pedestrian. So the system cannot detect:
 - pedestrians in the darkness or in poor lighting conditions;
 - partially visible pedestrians;
 - pedestrians less than approximately 80 cm;
 - pedestrians carrying large objects;
 - ...

In these conditions, the system may not react, may warn the driver or may brake inadvertently.

ADDITIONAL DRIVING AID FUNCTIONS



Deactivating the function

You must deactivate the function if:

- the camera area has been damaged (e.g. on the inside or outside of the windscreen);
- the front of the vehicle was damaged (impact, scratch on the radar, etc.);
- the vehicle is being towed (breakdowns);
- the windscreen is cracked or distorted (do not carry out windscreen repairs in this area; have it changed by an approved dealer);
- you are not driving on a paved road.

In the event of the system behaving abnormally, deactivate it and consult an authorised dealer.

Halting the function

You can halt the active braking function at any time by tapping the accelerator pedal or by turning the steering wheel in a collision avoidance manoeuvre.

ADDITIONAL DRIVING AID FUNCTIONS

Driver vigilance warning

The driver vigilance warning is a function that analyses the behaviour of the driver (driving style, vehicle steering, etc.) and alerts them if there is a risk of falling asleep.

It takes into account indicators such as:

- steering wheel movements;
- driver actions on other systems (indicators, brake pedal, etc.).



This function is an additional driving aid in case of risk of fatigue. The function does not operate on the vehicle. The function cannot, under any circumstances, replace the driver's responsibility during driving.

The driver must always adapt their driving according to their alertness, regardless of the system's indications.

Operation

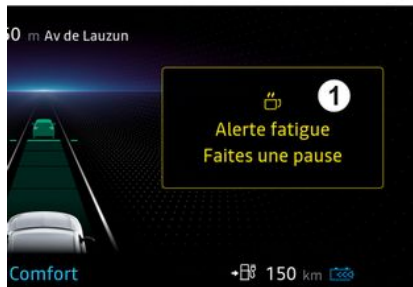

62487



61902

The function is set to notify the driver if:

- a few minutes have elapsed since the vehicle last stopped;
- the vehicle speed is greater than approximately 43 mph (70 km/h).

If there is a risk of fatigue or impaired attention, the "Vigilance alert Have a break" **1** message is displayed on the instrument panel, accompanied by a beep.

Press the switch **2** OK to clear the alert. It is advisable to stop as soon as possible for a break. After deleting the message, the system continues vigilance monitoring and issues a new warning if necessary.



The driver vigilance warning constantly monitors the driver's attention and can provide several warnings per journey. The system resets every time the engine is started.

ADDITIONAL DRIVING AID FUNCTIONS

Activation/deactivation



For safety reasons, carry out any adjustments while the vehicle is stationary.



Depending on the vehicle, depending on the length of time following the last time the engine was stopped, the alerts are reactivated:

- when the vehicle is unlocked;
- or
- when a door is opened;
- or
- when the engine is started.



When the alerts are deactivated, the system continues to assess the driver's state of fatigue.



Depending on the vehicle, alerts are automatically deactivated when the "Lane Centring" function is activated. To re-activate the warnings, the "Lane Centring" function must be deactivated. For more information → 232.



Depending on the vehicle, it may not be possible to deactivate alerts.

Activating and deactivating alerts using the "My Safety" button 3



The alerts can be deactivated or activated using "Custom" mode in the "My Safety" function → 195.

If the alerts have previously been deactivated using "Custom" mode:

- **to deactivate the alerts**, press the button **3** twice;
- **to reactivate alerts**, press the button **3** once.

ADDITIONAL DRIVING AID FUNCTIONS

Activating and deactivating the alerts from the multimedia screen

4



To activate or deactivate the alerts, please refer to the multimedia instructions.

Select "ON" or "OFF".

Limitation of the system operation

Some conditions can disrupt or damage the system operation, for example:

- certain driving styles (incorrect driving etc.);
- driving on a road in poor condition;
- strong side wind;
- The clock is wrongly configured (depending on vehicle);

- winding roads;
- trailer traction.

Operating faults

If the system detects a fault, the "Check Fatigue Warning System" mes-

sage and the  warning light are displayed on the instrument panel.

Have the system checked by an authorised dealer.

Detection of road signs

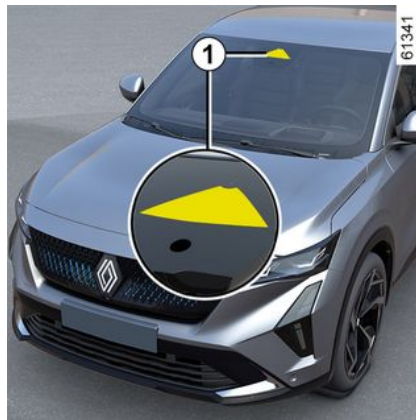

The system displays speed limits on the instrument panel according to road signs detected on the side of the road.

It mainly uses information taken from the camera **1** attached to the windscreen behind the rear view mirror. Depending on the country, the system also uses information from a map subscription to interpret certain signs (town entrance, etc.).

The sign displayed on the instrument panel changes when a road sign is detected by the system.

Once the speed limiter or the adaptive cruise control is activated, you can adapt the limited speed setpoint to the speed displayed on the instrument panel by the system (→ **248** and Adaptive cruise control).

If the detected limit speed is exceeded, the road sign display is modified to inform you.

Location of the camera 1

Make sure the windscreen is not obscured (by dirt, mud, snow, condensation etc.).

Special features

For vehicles with a map subscription:

- if the vehicle is travelling in a country where the speed units differ from those of the vehicle, the system displays the speed limit sign in the unit of the country, alongside the speed limit converted

3

ADDITIONAL DRIVING AID FUNCTIONS

to the unit used by the vehicle's instrument panel.

– for countries where the speed limit is reduced during rainy weather on some types of roads, the system may alter the detected speed limit after a few seconds of the windscreen wipers being activated.

For vehicles without a map subscription: when driving in a country where speed units differ from those on your vehicle, you can manually select the speed unit shown on the instrument panel (e.g. change the unit from miles to kilometres) in order to display accurate information ➔ 127.

The system does not take into account exceptional speed limit measures, such as peak pollution days.

Operation



Warning lights

The function displays the following warning lights:

2. Speed limit signs and additional speed limit signs (speed on exit ramp with arrow, speed with a caravan, speed limit with length of application, etc.)

3. Additional road signs (start of no overtaking zone).

If the speed limit is exceeded, a red circle around the panel flashes (warning light **3**) for a few seconds along with a sound signal to warn the driver.

It remains illuminated on the instrument panel as long as the vehicle speed is exceeding the speed limit.



Map subscription

Road sign detection is associated with a map subscription.

To manage the subscription, please refer to the multimedia instructions.

If there is no subscription, the system will be limited to taking into account the speed limit signs when they are detected by the camera.

The system will no longer take into account information related to the maps. The speed limit availability may be affected.

Activation/deactivation



For safety reasons, carry out any adjustments while the vehicle is stationary.

ADDITIONAL DRIVING AID FUNCTIONS



Depending on the vehicle, depending on the length of time following the last time the engine was stopped, the sound alert is reactivated:

- when the vehicle is unlocked;
- or
- when a door is opened;
- or
- when the engine is restarted.

Activating, deactivating the overspeed sound alert using the "My Safety" button 4



The sound alert can be deactivated or activated using "Custom" mode in the "My Safety" function ➔ 195.

If the sound alert has previously been deactivated using "Custom" mode:

- **to deactivate the sound alert**, press the button 4 twice. The indicator light on the button 4 goes out;
- **to reactivate the sound alert**, press the button 4 once. The indicator light on the button 4 lights up.

Activating, deactivating the overspeed sound alert from the multimedia screen 5



To activate or deactivate the sound alert, please refer to the multimedia instructions.

Select "ON" or "OFF".

Variation of the limited speed or cruising speed



To adapt the speed limiter, cruise control or adaptive cruise control setpoint to the detected speed limit, press the 6 switch.

Temporary unavailability

If the system is unavailable for reasons related to the camera or map data, the



symbol is displayed on the instrument panel. If there is still a problem, contact an approved dealer.

The system cannot detect the speed limit if:

ADDITIONAL DRIVING AID FUNCTIONS

- the windscreen is not clean;
- the camera is blinded by the sun;
- there is insufficient visibility (fog, etc.);
- the signs are not legible (snow, etc.) or are hidden (by another vehicle or by trees);
- the information taken from the map is not up to date.

Note: when the front camera is obscured, the "Front camera no visibility" message is displayed on the instrument panel. Clean the windscreen area in front of the camera.

Operating faults

When the system detects an operating fault, the  is displayed on the instrument panel.

In some cases, they are accompanied by the following message:

– « Driving assist unavailable » ;

or

– « Check Front camera » ;

or

– « Check Driving assist ». Consult an approved dealer.



This function is an additional driving aid. This function is not under any circumstances intended

to replace the due care and attention of the driver, who should at all times be in control of the vehicle.

The driver must always adapt their speed to the highway code and traffic conditions, regardless of system indications.

The system may not detect all speed limit signs or may interpret them incorrectly.

The driver should not ignore signs that are not detected by the system and should, as a priority, comply with the traffic signage and the highway code.

In the event of poor visibility (fog, snow, frost, etc.), it is possible that the system may not indicate the correct speed to the driver

Active driver assist

The "Active driver assist" is a driving aid system for use outside built-up areas, on wide roads with visible lines.

This system consists of the "**Adaptive cruise control Stop and Go**" function → 252 and the "**Lane Centring**" function.

This system enables the driver to:

- maintain vehicle speed based on a previously stored speed;
- adjust the distance between their vehicle and the vehicle in front;
- direct the trajectory of the vehicle in the lane;
- adapt the vehicle speed to the speed shown on the road signs, automatically or after confirmation by the driver (depending on the vehicle).

The Stop and Go adaptive cruise control function.

Depending on the country and subscription, based on information from a radar, camera or map data sent via a GSM connection, the Stop and Go adaptive cruise control makes it possible to maintain a selected speed, known as the cruising speed, while keeping a safe distance from the vehicle in front in the same lane.

The cruising speed can adjust automatically to a speed limit change (depending on the country and subscription).

If the vehicle in front stops, the Stop and Go adaptive cruise control may

ADDITIONAL DRIVING AID FUNCTIONS

brake your vehicle to a complete stop before setting off again.



Important: you should keep your feet near the pedals and your hands on the steering wheel at all times to prepare for any event.

The system controls acceleration and deceleration of your vehicle using the engine and braking system.

The Stop and Go adaptive cruise control function can be activated from 0 mph, according to conditions on the road (traffic, weather, etc.).

It is represented by the  → 252 symbol.

Note:

- the driver must observe the maximum speed limit and safe distances according to the legislation in the country where they are driving;
- the adaptive cruise control can brake the vehicle up to a third of the braking capacity. Depending on the situation, the driver may need to brake harder.



The Stop and Go adaptive cruise control does not trigger an emergency stop and its braking capability is limited.

The Lane Centring function

Using information from a camera, the "Lane Centring" function manipulates the steering system to direct the vehicle in the lane.

If the conditions allow it, the function is available between:

- 0 mph and a speed between 99 mph (160 km/h) and 112 mph (180 km/h) (depending on the version) with a vehicle in front;

or

- 37 mph (60 km/h) and a speed between 99 mph (160 km/h) and 112 mph (180 km/h) (depending on the version) without a vehicle in front.

The "Lane Centring" function is a comfort feature.

It is represented by the  warning light.

Note: in the event of a sharp bend, the function's lateral retention capacities are limited and require the driver to

take immediate action on the steering wheel.

Additional information

Depending on the vehicle, the "Active driver assist" function may be used with other driving aid functions.

Please note that:

- the system cannot be activated while the "Hands-free parking" function is in operation;
- When the "Lane Centring" function is in adjustment mode, this will suspend the "Lane departure prevention" function if it has already been activated. When the "Lane Centring" function is not controlling the steering system, the "Lane departure prevention" function may be reactivated if conditions allow.

ADDITIONAL DRIVING AID FUNCTIONS

Location of components

3

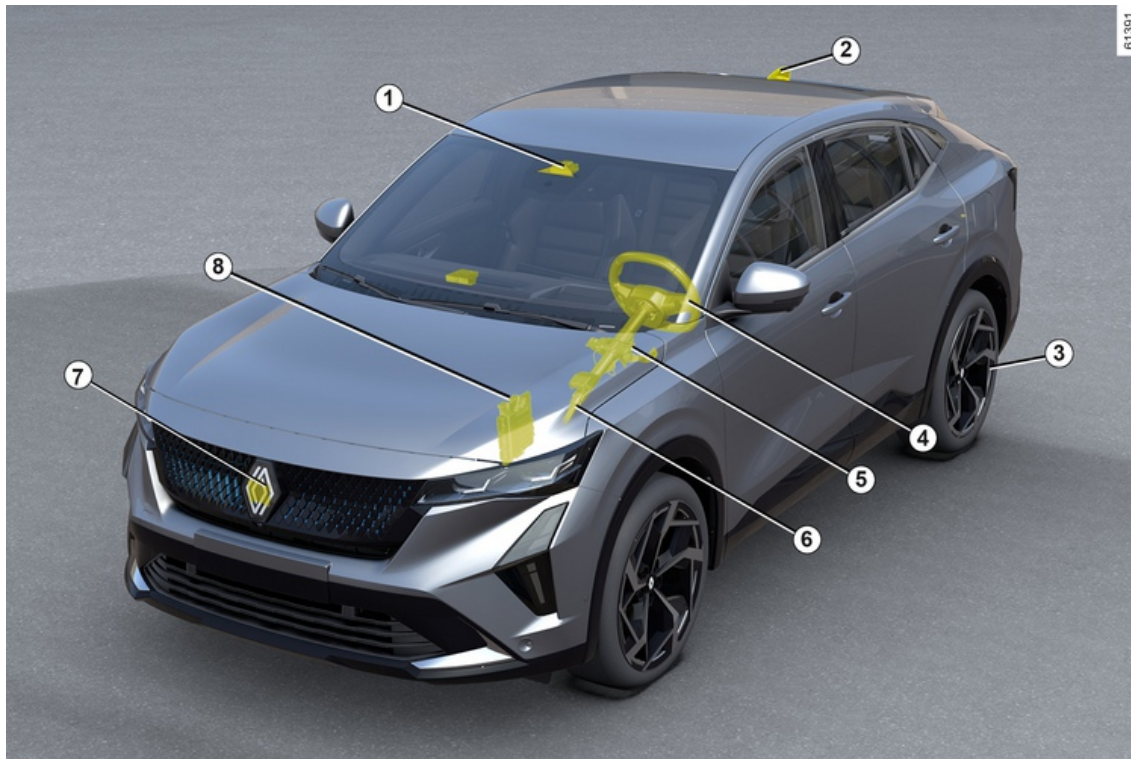

ADDITIONAL DRIVING AID FUNCTIONS

1 Camera

Detects markings on the ground and the position of vehicles on the various traffic lanes.

It receives information from the radar **6** and merges it with its own information to determine the trajectory and speed of the vehicle (acceleration/braking). Amongst other things, it controls the system activation/deactivation parameters (door opening status, etc.).

Depending on the vehicle, it processes information to detect the presence of the driver's hands on the steering wheel.

Make sure the windscreen is not obscured (by dirt, mud, snow, etc.).

2 Aerial and maps

(depending on the country and subscription)

Road maps and certain driving conditions (roundabouts and cornering) are downloaded according to the journey taken by the vehicle. The system can anticipate deceleration following a change of the speed limit indicated on road signs, depending on the parameters selected by the driver.

The system can also adjust the vehicle's speed when approaching a bend or roundabout.

3 Electronic parking brake

It the vehicle stationary under certain

conditions.

4 Capacitive sensor

Depending on the vehicle, it detects hands on the steering wheel.

5 Power-assisted steering

It operates the front wheels to guide the vehicle trajectory according to the information transmitted by the computer **1**.

6 Engine computer

It controls and directs the engine to carry out the required acceleration.

7 Radar

Calculates the distance between your vehicle and the vehicle in front.

The system's maximum range is approximately 150 metres. This may vary according to the road conditions (ground relief, weather conditions, etc.).

Ensure that the radar area is not obstructed (dirt, mud, snow, a badly fitted front number plate), impacted, modified (including painting) or hidden by any accessory fitted on the front of the vehicle (on the grille or logo etc.).

8 Active vehicle control

This system provides information on vehicle dynamics to the computer **1** (speed, lateral acceleration, etc.) and acts on the braking system to control deceleration and to keep the vehicle stationary.



The radar and camera zones must be kept clean and free of any tampering in order to ensure the proper operation of the system.

ADDITIONAL DRIVING AID FUNCTIONS

Controls

3



ADDITIONAL DRIVING AID FUNCTIONS

9. Switch for selecting/deselecting the driving aids, depending on the vehicle:

- the Active driver assist;
- Adaptive Cruise Control;
- speed limiter;
- OFF.

10. Safe distance settings

11. Puts the function on standby and stores the limited speed (0).

12 Recall the stored cruising speed (RES).

13



- Upwards: activates, increases cruising speed or recalls the stored cruising speed (SET/+).
- Downwards: activates, decreases cruising speed or stores the current speed (SET/-).

14 Pop-up button (depending on the vehicle): adapt the speed setpoint to

detected speed limits  → 229.

ADDITIONAL DRIVING AID FUNCTIONS

Displays on the instrument panel

17. Stop and Go adaptive cruise control function warning light .
18. Stored cruising speed.
19. Vehicle in front.
20. Stored safe distance
21. Left-hand and right-hand line indicators
22. "Lane Centring" function warning light .

Steering wheel 23

The driver must always keep their hands on the steering wheel.

If the driver turns the steering wheel with enough force, the "Lane Centring" function is interrupted to enable the driver to regain control of the vehicle.

Under certain conditions (sharp bends, etc.) a vibration may be triggered on the steering wheel to warn the driver that they must regain control of the vehicle.

If the driver does not handle the steering wheel (no hands are detected) the "Lane Centring" function is deactivated after several alerts.

Activating/deactivating the "Active driver assist" function

Activating the function



To activate the function, press the switch **9** as many times as necessary to activate it.

The warning light **22**  is displayed in grey on the instrument panel. Then press the steering wheel control **13** upwards (SET/+) or downwards (SET/-).

The "Active driver assist", consisting of the Adaptive cruise control Stop and Go and the "Lane Centring" function, is then activated.

The green warning light **22**  and the left-hand and right-hand line indicators **21** are displayed on the instrument panel to confirm that the function is in operation and directing your vehicle towards the centre of the lane.

You can interrupt the "Lane Centring" function at any time by forcefully turning the steering wheel. As soon as you stop turning the steering wheel, the "Lane Centring" function is reactivated.

Note: you must keep your hands on the steering wheel when using the "Lane Centring" function. Under no circumstances should you take your hands off the steering wheel.

Deactivating the function

Press the switch **9**. Deactivation of the function is confirmed by the disappearance

of the warning light **22**  and the right-hand and left-hand line indicators **21** from the instrument panel.

Note: if the "Lane departure prevention" function was previously activated and the conditions allow, it will automatically reactivate.

Adjusting the position in the lane

(depending on the vehicle)

ADDITIONAL DRIVING AID FUNCTIONS



To activate the position in the lane, the "Lane Centring" function must be in adjustment mode, the green warning light **22** must be displayed on the instrument panel and the vehicle speed must be below 31 mph (50 km/h).

In these conditions, you can adjust your position in the lane by turning the steering wheel slightly to the right or left, so that the vehicle shifts to the selected side without the "Lane Centring" function being deactivated. As soon as your offset is at least about 15 cm from the middle of the lane, without the vehicle approaching less than about 30 cm from the edge of the lane, you have about 10 seconds to adjust the offset precisely. The vehicle then remains in the offset position when you

stop exerting effort to turn the steering wheel. The lines **21** indicate the offset applied. To return to the centre of the lane, turn the steering wheel slightly in the opposite direction, then stop trying once the vehicle has reached the centre.

According to certain conditions (e.g. bend, speed), the vehicle may be re-centred automatically.

"Lane Centring" function on standby

The "Lane Centring" function is put on standby automatically in the following cases:

- the system no longer detects the lines or only one line is detected in your lane;
- the lane is too narrow or too wide;
- the system does not detect any hands on the steering wheel;
- in some driving conditions (roundabout, intersection, the bend is too sharp, etc.);
- the vehicle speed is greater than approximately 99 mph or 112 mph (160 km/h or 180 km/h), depending on the vehicle;
- the vehicle speed is below approximately 30 mph (48 km/h), without a vehicle in front;
- the vehicle crosses a line;

– the system is temporarily disrupted (for example: camera obscured by dirt, mud, snow, condensation, etc.).

Certain actions carried out by the driver also suspend the "Lane Centring" function:

- activating the indicators;
- turning the steering wheel with enough force.

The function is confirmed to be on standby by the appearance of the grey

warning light **22**  and the left-hand and right-hand line indicators **21** on the instrument panel.



Important: you should keep your feet near the pedals and your hands on the steering wheel at all times to prepare for any event.

Once the conditions are met, the function again directs the vehicle in the

lane. The warning light **22**  and the left-hand and right-hand line indicators **21** are displayed in green on the instrument panel.

ADDITIONAL DRIVING AID FUNCTIONS



You can affect **the vehicle trajectory** at any point by turning the steering wheel.

3

"Keep hands on steering wheel" warning

63528



When the "Lane centering assist." function no longer detects your hands on the steering wheel, several warning levels will be triggered:

- **after approximately 15 seconds**, the "Keep hands on steering wheel" message appears in yellow on the instrument panel;
- **after approximately 30 seconds**, the "Keep hands on steering wheel"

message appears on the instrument

panel and the warning light **24**  appears in red, accompanied by a gradually increasing sound signal;

- **after approximately 35 seconds**, if the driver does not put their hands on the steering wheel after the warning is displayed, an audible warning sounds continuously. The brakes are then briefly applied repeatedly to inform the driver that they must retake control of the vehicle by putting their hands on the steering wheel. If the driver does not respond, the "Active driver assist" activates the hazard warning lights and slows down the vehicle until it comes to a complete stop.



The driver can interrupt this manoeuvre at any time by placing their hands on the steering wheel, braking or deactivating the "Active driver assist".

– After the vehicle has stopped, the electronic parking brake is automatically applied, the warning lights stay

on, the warning light **24**  goes out and the "Lane centering deactivated" message appears in red on the instrument panel to inform you.



In the first two alert levels, when the system again detects the presence of the driver's hands on the steering wheel, the system stops the alerts. The function continues to direct the vehicle in the lane.

Note: in some situations, the "Lane Centring" function may no longer detect your hands on the steering wheel and may emit an alert:

- the driver is holding the steering wheel very lightly;
- the driver is wearing gloves;
- ...



Warning concerning the capacitive sensor: fitting any accessory on the steering wheel is prohibited (protective cover, etc.).

ADDITIONAL DRIVING AID FUNCTIONS

In the case of a sharp bend

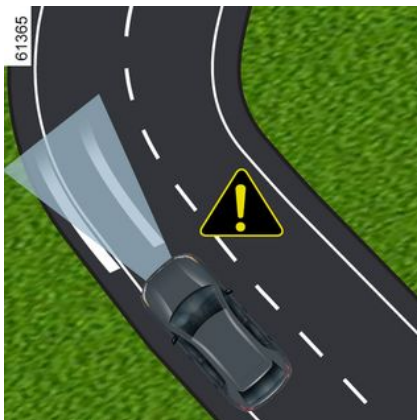

In the case of a sharp bend, and depending on the vehicle speed, the function's side retaining capacities will be limited and require the driver to carry out immediate action on the steering wheel so that the vehicle remains in the lane.

If the driver does not intervene, the function triggers the vibration of the steering wheel to signal that the vehicle is about to breach a line and that the driver needs to carry out immediate action.

The warning light **22**  and the left-hand or right-hand line indicator **21**

concerned appear in red on the instrument panel.

If the vehicle crosses a line completely and moves out of its lane or if the bend is too sharp, the "Lane Centring" function is put on standby.

The function is confirmed to be on standby by the appearance of the grey

warning light **22**  and the left-hand and right-hand line indicators **21** on the instrument panel.

 The "Lane Centring" function cannot assist the driver when negotiating a roundabout or an intersection and may automatically switch to standby. In all cases, the driver must always turn the steering wheel to manage the vehicle trajectory under these driving conditions.

Operating faults

If an operating fault is detected in relation to the "Lane Centring" function, the "Driving assist unavailable" or "Check Driving assist" message is displayed on the instrument panel and the function is deactivated.

Consult an approved dealer.

ADDITIONAL DRIVING AID FUNCTIONS

Warning



The "Active driver assist" is an additional driving aid. It can under no circumstances replace the driver's responsibility to respect speed limits and safe distances and to be vigilant.

The driver must always be in control of the vehicle.

The driver must always adapt their trajectory and speed according to the surroundings and driving conditions, regardless of system indications.

Except for lines delimiting lanes and the speed limit signs within the limits of the system's detection capacity, the road sign information (other traffic signs, traffic lights, pedestrian crossings, etc.) are not recognised by the system. These do not trigger any alert or reaction by the system.

The "Active driver assist" uses the "Stop and Go" adaptive cruise control and "Lane centering assist." functions. The system should under no circumstances be taken to be an obstacle detector or an anti-collision system.

Use the "Active driver assist" exclusively outside built-up areas, on wide roads with visible lines.

It must not be used in heavy traffic, on winding or slippery roads (black ice, aquaplaning, gravel) or during bad weather (fog, rain, side winds etc.).

There is a risk of accidents.

System servicing/repairs

– In the event of an impact, the radar and/or camera alignment may be changed and its operation may consequently be affected. Deactivate the system and consult an authorised dealer.

– Any work in the proximity of the radar and/or camera (replacements, repairs, windscreen modifications, paintwork etc.) must be carried out by a qualified professional.

Only an authorised dealer is qualified to service the system.

ADDITIONAL DRIVING AID FUNCTIONS



Deactivating the system

You must deactivate the system if:

- the vehicle is travelling on a winding road;
- the vehicle is being towed (breakdowns);
- the vehicle is towing a trailer or a caravan;
- the vehicle is being driven in a tunnel or close to a metallic structure;
- the vehicle arrives at a toll point, a roadwork area or on a narrow lane;
- the vehicle is being driven up or down a very steep slope;
- the visibility is poor (glaring sun, fog, etc.);
- the weather conditions are poor (rain, snow, side winds, etc.);
- the vehicle is being driven on a slippery road surface (rain, snow, gravel, etc.);
- the camera area has been damaged (e.g. interior or exterior windscreen area); the windscreen is cracked or distorted;
- the radar area has been damaged (impacts, etc.);
- the surface of the steering wheel is damaged or damp.

In the event of the system behaving abnormally, deactivate it and consult an authorised dealer.

ADDITIONAL DRIVING AID FUNCTIONS



Some conditions can disrupt or damage the system operation, for example:

- obstruction of the windscreen or the radar area (by dirt, ice, snow, condensation etc.) Frequently check the cleanliness and condition of the windscreen, front wiper blades and front bumper;
- a complex environment (tunnel, etc.);
- poor weather conditions (snow, heavy rain, hail, black ice, etc.);
- poor visibility (night, fog, etc.);
- poor contrast between the vehicle preceding it and the surrounding area (e.g. white vehicle in a snowy area, etc.);
- being dazzled (glaring sun, lights of vehicles travelling in the opposite direction; etc.);
- narrow, winding or undulating road (tight bends, etc.);
- the tar lines detected as a line by the system;
- narrowing/widening lanes;
- road markings which are worn, lacking in contrast or very widely spaced from one another (lines partially erased; etc.);
- multiple markings on the road (roadworks area, slip roads connecting to adjacent motorways, hard shoulder, etc.);
- road signs that do not include an arrow, located on a motorway exit;
- an area with low connectivity that makes it impossible to geolocate the vehicle, or maps that are not up-to-date;
- a vehicle with a significant difference in speed;
- use of mats not adapted to the vehicle. On the driver's side, only use mats suitable for the vehicle, attached with the pre-fitted components, and check the fitting regularly. Do not lay one mat on top of another. **There is a risk of wedging the pedals.**

In these cases:

- **Risk of unwanted braking or acceleration.**
- **Risk of unwanted, incorrect correction or no correction of trajectory.**

Many unforeseen situations may affect the system operation. Certain objects or vehicles that can appear in the camera or radar detection zone may be interpreted by the system incorrectly, possibly leading to inappropriate acceleration or braking. **You should always be attentive to sudden events that might occur while you are driving. Always maintain your vehicle under control by keeping your feet near the pedals and your hands on the steering wheel, so that you are ready to act in any event.**

ADDITIONAL DRIVING AID FUNCTIONS

Active emergency braking in reverse gear

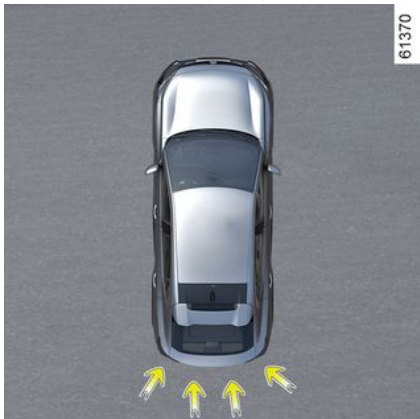

In addition to the "Park Assist" function → 268 and using information from the four central sensors located at the rear of the vehicle, the system detects fixed obstacles located behind your vehicle. If there is a significant risk of collision, the system automatically causes the vehicle to brake.

Note: make sure that the four central sensors located at the rear of the vehicle are not obscured (by dirt, mud, snow, etc.).

Operation



Fixed rear obstacle detection

When in reverse gear and moving at between approximately 2 mph and 6 mph (3 km/h and 10 km/h), if there is a risk of collision with a fixed obstacle, the system **automatically brakes the**

vehicle. A visual warning  2 is displayed on the multimedia screen 1, accompanied by a beep.

Once the vehicle has stopped, the vehicle must be held stationary by the driver keeping their foot on the brake pedal.



This function is an additional driving aid. This function is not under any circumstances intended to replace the due care and attention of the driver, who should at all times be in control of the vehicle.

3

ADDITIONAL DRIVING AID FUNCTIONS



An impact to the underside of the vehicle while manoeuvring (e.g. striking a post, raised kerb or other street furniture) may result in damage to the vehicle (e.g. deformation of an axle).

To avoid any risk of accident, have your vehicle checked by an approved dealer.

Activating or deactivating the system



To activate or deactivate the function, select the "Vehicle" world, then "Park-

ing aids". Select "Active emergency braking in reverse gear".

If the function is deactivated, the warn-

ing light  is displayed on the multimedia screen.

Operating faults

When the system detects an operating fault, active emergency braking in reverse gear is automatically deactivated.

The warning light  is displayed on the multimedia screen accompanied by, depending on the type of malfunction, the following message on the instrument panel:

- "Parking sensors unavailable";
- or
- "Check parking sensors";
- or
- "Driving aids unavailable";
- or
- "Check driving aids".

Depending on the vehicle, the message is accompanied by the display of

the  warning light on the instrument panel.

Clean the ultrasonic sensors. If there is still a problem, contact an approved dealer.

If the vehicle is fitted with a towbar recognised by the system and a trailer has been connected, active emergency braking in reverse gear is automatically deactivated and the "Trailer: parking sensors off" message is displayed on the instrument panel, accompanied by the warning light 

on the multimedia screen.

ADDITIONAL DRIVING AID FUNCTIONS

Warnings



Active emergency braking in reverse gear

This function is an additional driving aid. This function cannot, under any circumstances, replace the vigilance and responsibility of the driver.

Some climatic and environmental conditions can disrupt or damage the system. As a consequence, the driver should always be ready for sudden incidents while driving: always ensure that there are no small, narrow moving obstacles (such as a child, animal, pushchair, bicycle, stone, post, etc.) in the blind spot when manoeuvring.

The triggering of this function may be delayed or prevented when the system detects clear signs of control of the vehicle by the driver (action on the steering wheel, pedals etc.).

System servicing/repairs

- In the event of an impact, the rear sensors and their performances may be affected. Deactivate the function and consult an authorised dealer.
- Any work in the area where the sensors are located (repairs, replacements, bumper modifications etc.) must be carried out by a qualified professional.

Only an authorised dealer is qualified to service the system.

Deactivating the function

You must deactivate the function if the vehicle is being towed (breakdown recovery) or if the vehicle is fitted with a towbar that is not recognised by the system.

In the event of the system behaving abnormally, deactivate it and consult an authorised dealer.

SPEED LIMITER

The speed limiter function controls the engine and braking system to help you not to exceed a driving speed that you have chosen, known as the **limit speed**.

The speed limiter function can be activated from 0 mph to 112 mph (180 km/h).



With ECO mode activated, the limited speed setpoint cannot exceed the maximum speed authorised in ECO → 178 mode.

Controls



1. Switch for selecting/deselecting the driving aids, depending on the vehicle:

- the Active driver assist;
- Adaptive Cruise Control;
- cruise control;
- speed limiter;
- OFF.

2. Puts the function on standby and stores the limited speed (0).

3. Recalling the stored limit speed (RES).

4.

- Upwards: activates, increases limited speed or recalls the stored limited speed (SET/+).
- Downwards: activates, decreases limited speed or stores the current speed (SET/-).

5. Pop-up button (depending on the vehicle): adapt the speed setpoint to

detected speed limits  → 229.



Depending on the vehicle, you can link the speed limiter function to the "Road sign detection" function → 229 by pressing the switch 5.

When the "OFF" mode is activated before the ignition is switched off, the "Speed limiter" function will be activated by default the next time the engine is started.

Driving

When a limit speed has been set but not yet reached, driving is similar to driving a vehicle without the speed limiter function.

Once you have reached the stored speed, no effort on the accelerator pedal will allow you to exceed the programmed speed except in an emergency (refer to information on "Exceeding the limit speed").

SPEED LIMITER

Switching on



Press switch **1** as many times as necessary to select the speed limiter **A**.



The **6** warning light appears in grey. The "Speed limiter ready: SET to activate" message is displayed on the instrument panel accompanied by dashes to indicate that the speed limiter function is activated and waiting for a limit speed to be stored.

Note: depending on the vehicle, when the vehicle is started, the speed limiter is automatically selected if the function **A** or OFF was selected the last time the vehicle was stopped.

To store the current speed, press the switch **4** upwards (SET/+) or downwards (SET/-): the limited speed replaces the dashes and, depending on the vehicle, the warning light **6** appears in white.

The minimum stored speed is 19 mph (30 km/h).

Varying the limit speed



You can change the limit speed by repeatedly pressing or pressing and holding on control **4**:

- upwards (SET/+) to increase the speed;
- downwards (SET/-) to decrease the speed.

Automatic speed limiter with speed limit sign recognition

(depending on subscription: without a subscription this function cannot be ac-

SPEED LIMITER

tivated. To manage your subscription, see the multimedia instructions.)

Using the camera, the "Road sign detection" function → 229 and the map associated with the subscription, the system automatically limits the vehicle speed when a speed limit road sign is identified and passed.

Activation/deactivation

From the multimedia screen, in the "Vehicle" world, select "Driving aids". Then, from the "Speed adaptation" menu view the "Adaptive cruise control" field and select "To speed limits".

Note: you can also activate/deactivate by pressing and holding the contextual button 5.

Exceeding the limit speed

It is possible to exceed the limit speed at any moment. To do this, press the accelerator pedal **firmly down** beyond the point of resistance.

While the speed is being exceeded, the speed limiter flashes red on the instrument panel.

Then, release the accelerator pedal: the speed limiter function will return as soon as you reach a speed lower than the memorised speed.



You must keep your feet near the pedals to be ready to react in an emergency.



If the speed limiter is not available (after several attempts to activate), contact an approved dealer.

Putting the function on standby



The speed limiter function is suspended when you press switch 2 (0).

The limit speed is stored and displayed in grey on the instrument panel.

Recalling the limit speed

If a speed has been stored, you can recall it by pressing the switch 3.



When the speed limiter is set to standby, pressing the 4 control upwards or downwards reactivates the function without taking into account the stored speed: it is the speed at which the vehicle is moving that is taken into account.

SPEED LIMITER

Switching off the function

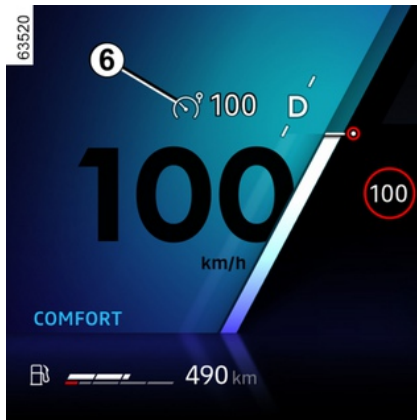

The speed limiter function is interrupted when you press the **1** switch to deselect the limiter. In this case, the speed is no longer stored.

The **6** warning light disappears from the instrument panel to confirm that the function has stopped.

The minimum stored speed is 19 mph (30 km/h).



To exit the driving assistance, press switch **1** as many times as necessary until OFF. The message "Driving Assistance deactivated" appears on the instrument panel.

In this case, the next time the engine is started, the "Speed limiter" function will be activated and waiting for a speed limit to be stored.

ADAPTIVE CRUISE CONTROL

Based on information from a radar or camera, the Stop and Go adaptive cruise control function gives you the option of maintaining a selected speed, known as the cruising speed, while keeping a safe distance from the vehicle in front in the same lane.

Depending on the vehicle, when the "Road Sign Detection" function is activated ➔ **229**, the system can adapt the speed of your vehicle according to the speed limit signs recognized by the camera.

Depending on the country and subscription, the system will use the camera and the map to adjust the vehicle speed in advance according to the context and road incidents (roundabouts, bends, upcoming road signs or speed limit zones).

If the vehicle in front stops, the Stop and Go adaptive cruise control may brake your vehicle to a complete stop before allowing the vehicle to move on again.

The system controls acceleration and deceleration of your vehicle using the engine and braking system.

The system's maximum range is approximately 130 metres. This may vary according to the road conditions (ground relief, weather conditions, etc.).

The Stop and Go adaptive cruise control function can be activated while the vehicle is travelling at a speed up to 112 mph (180 km/h), depending on road conditions (traffic, weather, etc.).

The function is indicated by the  symbol.

Note:

- the driver must observe the maximum speed limit and safe distances according to the legislation in the country where they are driving;
- the adaptive cruise control can brake the vehicle up to around a third of the braking capacity. Depending on the situation, the driver may need to brake harder.

 While ECO mode is activated, the cruising speed cannot exceed the ECO mode maximum speed ➔ **178**.

 The regenerative braking system and the paddles are not available when the cruise control or the adaptive cruise control function is activated.

 The Stop and Go adaptive cruise control does not trigger an emergency stop and its braking capability is limited.

ADAPTIVE CRUISE CONTROL



This function is an additional driving aid.

It can under no circumstances replace the

driver's responsibility to respect speed limits and safe distances or to be vigilant.

The driver must always be in control of the vehicle.

The driver must always adapt their speed according to the surroundings and traffic conditions.

Use the Stop and Go adaptive cruise control function outside built-up areas, on wide roads with visible lines.

The cruise control may have limited operation on very winding or slippery roads (black ice, aquaplaning, gravel) or during bad weather (fog, rain, side winds, etc.)

There is a risk of accidents.

Location of the camera 1



Make sure the windscreen is not obscured (by dirt, mud, snow, etc.).

Location of the radar 2

Ensure that the radar protection plate is not obstructed (dirt, mud, snow, a badly fitted number plate), impacted, modified (including painting) or hidden by any accessory fitted on the front of the vehicle (on the grille or logo, etc.).

Controls



3. Switch for selecting/deselecting the driving aids, depending on the vehicle:

- the Active driver assist;
- Adaptive Cruise Control;
- cruise control;
- speed limiter;
- Off.

4. Put the function on standby (with cruising speed stored) (0).

5. Recall the stored cruising speed (RES).

6.

- Upwards: activates, increases cruising speed or stores the current speed (SET/+).

ADAPTIVE CRUISE CONTROL

– Downwards: activates, decreases cruising speed or stores the current speed (SET/-).

7. Pop-up button (depending on the vehicle): adapts the speed setpoint to

detected speed limits  → 229

8. Adjusting the following distance.



Depending on the vehicle, you can link the cruise control function to the "Road sign detection" function → 229 by pressing the switch 7.



The radar and camera zones must be kept clean and free of any tampering in order to ensure the proper operation of the system.

Displays



9. Stop and Go adaptive cruise control warning light.

10. Stored cruising speed.

11. Vehicle in front.

12. Stored safe distance



Important: you should keep your feet near the pedals at all times to prepare for any event.

Switching on



Press switch 3 to select the adaptive cruise control 13. The 9 warning light appears in grey. The "Adaptive Cruise Control ready: SET to activate" message appears on the instrument panel accompanied by dashes to indicate that the cruise control function is in operation and waiting to store a cruising speed.

This function cannot be activated when:

- the parking brake is applied;
- the driver's seat belt is not fastened;
- one or more doors are incorrectly closed;
- the "Hands-free parking" function is already activated.

ADAPTIVE CRUISE CONTROL

The "Adaptive Cruise Ctl unavailable" message is displayed on the instrument panel.

Activating cruise control

While the vehicle is stationary or moving at a steady speed, push the control **6** upwards (SET/+) or downwards (SET/-): the function is activated and the current speed is stored.

The minimum cruising speed is 19 mph (30 km/h).

The cruising speed **10** replaces the dashes and cruise control is confirmed by the appearance of the cruising speed in green and warning light **9**.

If you try to activate the function when the vehicle is travelling over 112 mph (180 km/h), the "Speed invalid" message will be displayed and the function will remain deactivated.

Once a cruising speed is memorised and the cruise control function is active, you may lift your foot off the accelerator pedal.

Note: if your vehicle speed is lower than about 19 mph (30 km/h), the function uses a default cruising speed of 19 mph (30 km/h). The vehicle will accelerate until it reaches the stored cruising speed.

Activating cruise control with speed limit sign recognition (display A)



(depending on the vehicle)

If the vehicle is equipped with the "Road Sign Detection" → 229 function, press the contextual button **7** to adapt the vehicle's speed to the **14** speed limits detected by the camera.

When passing the sign, the cruising speed **10** adopts the value of the detected speed **14**.

Adjustment

You can choose to apply to cruising speed **10** a systematic speed deviation in relation to the detected speed limits **14**.

From the multimedia screen, in the "Vehicle" World, select "Driving assistance". Then, on the "Speed management" menu, activate the "Adjust speed limitations" field and select the desired difference (from -6 mph (10 km/h) to +6 mph (10 km/h), above 30 mph (50 km/h)).

Activating cruise control with advance speed limit sign recognition (display B)

(depending on subscription)

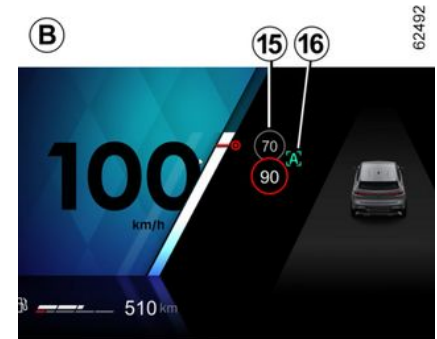

Using the camera, the "Road sign detection" function → 229 and the map associated with the subscription, the system anticipates the automatic ad-

ADAPTIVE CRUISE CONTROL

justment of the vehicle speed until the next sign is identified **15**.

Activation/deactivation

From the multimedia screen, in the "Vehicle" World, select "Driving assistance". Then, from the "Comfort" menu, select "Speed limit adaptive cruise control".

The letter "A" **16** is displayed on the instrument panel to confirm the activation of the cruise control with advance speed limit sign recognition.



Note:

– you can also activate/deactivate the function by pressing and holding the pop-up button **7**;

– in some cases (if there is a significant difference between the vehicle speed and limited speed), the system may request that you validate the speed manually by pressing the pop-up button **7**: the white square **17** is displayed around the indicated speed to inform you.



Cruise control with advance speed limit sign recognition is associated with a subscription. If there is no subscription, this function cannot be activated.

To manage the subscription, please refer to the multimedia instructions.

Operation

With the function activated, the following speeds are displayed on the instrument panel:

- cruising speed **10**;
- the current speed limit detected by the system on the section of road on which the vehicle is travelling **14**;
- the speed detected by the system on the next road section or speed limit zone **15**.

The detected speed **15** is taken into account by the system. The vehicle speed adjusts gradually, until it becomes the cruising speed **10**, without any action from the driver. The speed indicated on **15** is displayed on **14** when passing the sign or zone identified.

The driver must always stay vigilant regarding the speed applied by the system and remains responsible for the vehicle speed.

When the function is not activated or the subscription is no longer active, the operation is identical to setting the cruising speed with speed limit sign recognition (display **A**).

Activating cruise control with advance recognition of the road layout (display **C)**

(depending on subscription)

ADAPTIVE CRUISE CONTROL



Using the camera, the "Road sign detection" → 229 function, and the mapping purchased with the subscription, the system can anticipate and manage the automatic adaptation of the cruising speed **10**, when the vehicle approaches a roundabout or a bend.

If the vehicle is approaching a bend or roundabout, a **18** warning light appears on the instrument panel. The vehicle adjusts its speed to a speed appropriate to the feature detected.



The driver must always stay vigilant regarding the speed applied by the system and remains responsible for the vehicle speed.

Activation/deactivation

From the multimedia screen, in the "Vehicle" World, select "Driving assistance". Then, from the "Comfort" menu, select "Road layout adaptive cruise control".

When the function is not activated or the subscription is no longer active, operation is the same as setting the cruising speed with speed limit sign recognition (display **A** or, depending on the subscription, setting the cruising speed with advanced speed limit sign recognition (display **B**).

The following symbols show the features taken into account by the system:

-  roundabout;
-  bend.

 Cruise control with advance recognition of the road layout is associated with a subscription.

If there is no subscription, this function cannot be activated.

To manage the subscription, please refer to the multimedia instructions.

Controlling cruising speed

You can resume control of the vehicle speed at any time by:

- putting the function on standby:
 - by pressing the brake pedal;
 - or by pressing the switch **4** (0);
- by pressing the driving aids selection/deselection switch **3**.

When automatically adapting the speed to the signs and/or road layout, it is possible to ignore these events. Press the control **5** upwards (SET/+) to recall the stored cruising speed.

Safe distance control activation

As soon as cruise control is activated, the default safe distance **13** is displayed in green on the instrument panel.

If the system detects a vehicle in your lane, an outline of a vehicle **11** appears above the distance gauge **12** on the instrument panel.

Your vehicle adapts its speed to that of the vehicle in front and applies the brakes if necessary (the brake lights come on) in order to maintain the distance displayed on the instrument panel.

Note: the size of the **11** outline varies according to the distance separating you from the vehicle in front. The large-

ADAPTIVE CRUISE CONTROL

er the outline, the closer the vehicle in front.

Setting the cruising speed

You can vary the speed by pressing repeatedly (for low variation) or pressing and holding (for high variation) the control **6**:

- downwards: (SET/-) to decrease the speed;
- upwards (SET/+) to increase the speed.

Adjusting the following distance

You can vary the safe distance from the vehicle in front at any time by pressing switch **8** repeatedly.



The horizontal distance gauge on the instrument panel indicates the various available safe distances:

- distance gauge **G**: long distance (corresponding to approximately 2.4 seconds);
- distance gauge **F**: intermediate distance 2 (corresponding to approximately 2 seconds);
- distance gauge **E**: intermediate distance 1 (corresponding to approximately 1.6 second);
- distance gauge **D**: short distance (corresponding to approximately 1.2 seconds).

The selected distance gauge appears in green on the instrument panel. The other gauges remain in grey.

Note: the distance must be set according to the traffic level, local regulation and weather conditions.



The safe distance is adjusted by default on the distance gauge **F**.

Exceeding the cruising speed

The cruising speed may be exceeded at any time by applying the accelerator pedal.

If it is exceeded, the cruising speed **10** appears in yellow.

If the driver presses the accelerator pedal, the "Distance Control" function will no longer operate.

Then, release the accelerator pedal: the cruise control and safe distance control will automatically resume the speed and distance instructions that you had previously selected.

Overtaking manoeuvre

If you want to overtake the vehicle in front and your speed is over 43 mph (70 km/h) only, activating the direction indicators temporarily reduces the following distance and triggers acceleration to facilitate overtaking.

Stopping the vehicle and setting off

If the vehicle in front slows down, the system adapts its speed to bring the vehicle to a complete stop if necessary (e.g. in heavy traffic). The vehicle stops a few metres from the vehicle in front.

When the vehicle in front sets off again:

- if the stop lasts for less than thirty seconds, the vehicle will start again

ADAPTIVE CRUISE CONTROL

without any action required from the driver.

Note: the driver should always be ready for sudden incidents while driving and remains responsible for controlling the vehicle: if the system detects a pedestrian in the area around the vehicle, the automatic restart will be inhibited until the next stop;

- if the stopping time exceeds approximately thirty seconds, for the vehicle to set off again it is necessary to either:
 -
 - press the pedal
 - press once on button **5** (RES)

The "Press RES or accelerate to restart cruising" message appears on the instrument panel to confirm this.

If the stop exceeds around three minutes, the electronic parking brake is automatically applied and the Stop and Go adaptive cruise control is deactivated.

The indicator light **9** goes out to confirm that the function is deactivated.

Putting the function on standby

You can set the function to standby when:

- you press switch **4** (0) ;
- you apply the brake pedal while the vehicle is moving.

The function is deactivated by the system if:

- you put the gear control in position P, R or N ;
- you unbuckle the driver's seat belt;
- you open one of the opening elements;
- you press the engine start/stop button;
- the slope is too steep;
- certain driving aids and correction devices are triggered (active emergency braking, ABS, ESC...).

Note: Depending on the vehicle, if the reception of the connected data is not optimal, the system automatically switches on standby the advance speed limit sign recognition and/or advance recognition of the road layout functions.

The two functions are automatically reactivated as soon as reception of the connected data becomes optimal again.

In all circumstances, the standby status is confirmed when the warning lights appear in grey and the "Adaptive cruise control disconnected" message appears on the instrument panel.



Stopping the Stop and Go adaptive cruise control function or putting it on standby will not provide a rapid decrease in speed: you must press the brake pedal to brake if necessary.

Exit from standby

Based on the stored cruising speed

If a speed is stored, it can be recalled, once you are sure that the road conditions are suitable (traffic, road surface, weather conditions, etc.). Press the **6**, switch upwards in the range of valid speeds.

When the stored speed is recalled, activation of the cruise control is confirmed by the illumination of the cruising speed in green.

Note: if the stored speed is higher than the current speed, the vehicle will accelerate to reach that speed.

Based on the current speed

When the cruise control is set to standby, pressing switch **6**, downwards reactivates the cruise control function without taking into account the stored speed: it is the speed at which the ve-

ADAPTIVE CRUISE CONTROL

hicle is moving that is taken into account.

"Take control of the vehicle" warnings

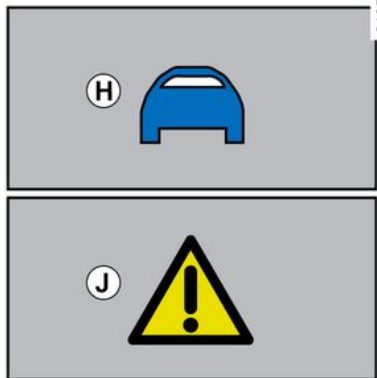

In some situations (e.g. coming up on a much slower vehicle, vehicle in front changing lanes quickly, etc.) the system may not have time to react.

Depending on the situation, the system sounds a beep associated with:

– the orange alert **H** if the situation requires the driver's attention;

or

– the red alert **J** accompanied by the "Brake" message if the situation requires immediate action by the driver.

In all situations, react accordingly and perform the appropriate manoeuvres.

Switching off the function



The Stop and Go adaptive cruise control function is deactivated when you press the switch **3**.

The **9** warning light disappears from the instrument panel to confirm that the function has stopped.

Temporary unavailability (radar)



The radar is able to detect vehicles in front of your vehicle. The system cannot operate correctly if the radar detection area is obscured or if its signal is disrupted.

If the radar detection area is obstructed or the radar signal is disrupted, the message "Front radar no visibility" is displayed on the instrument panel and the adaptive cruise control Stop and Go is interrupted.

The green warning light **9** disappears to confirm that the function has been automatically deactivated.

Ensure that the radar area remains clean and is not obstructed by snow, mud, a badly fitted number plate or by

ADAPTIVE CRUISE CONTROL

any accessory fitted on the front of the vehicle (on the grille), or hidden by any accessory fitted on the front of the vehicle (on the grille or logo, etc.).

Conditions in certain geographical areas may hinder the function, for example:

- arid zones, tunnels, long bridges or lightly used roads without road lines, without signs or trees nearby;
- a military or airport zone.

You must leave such areas in order for the function to work.

In all cases, if the message is not erased after the engine is restarted, please contact an authorised dealer.

Temporary unavailability (camera)

The system cannot operate if the camera is obscured (by dirt, mud, snow, condensation, etc.).

If the visibility of the camera is reduced, the performance of the Stop and Go adaptive cruise control will be reduced. Remain vigilant.

Operating faults

If an operating fault is detected on the Stop and Go adaptive cruise control function, the "Check adaptive cruise control" message appears on the in-

strument panel and the Stop and Go adaptive cruise control function is interrupted.

If an operating fault is detected on one or more of the system components, the Stop and Go adaptive cruise control function is interrupted.

Depending on the type of malfunction, the message is displayed on the instrument panel:

- "Check front camera" message accompanied, depending on the vehicle,

by the warning light  ;

- "Check front radar" message accompanied, depending on the vehicle, by

the warning light  ;

- "Check camera/radar" message accompanied, depending on the vehicle,

by the warning light  ;

- "Check vehicle" message accompa-

nied by the warning light  .

Consult an approved dealer.

Limitations of system operation

Vehicle detection

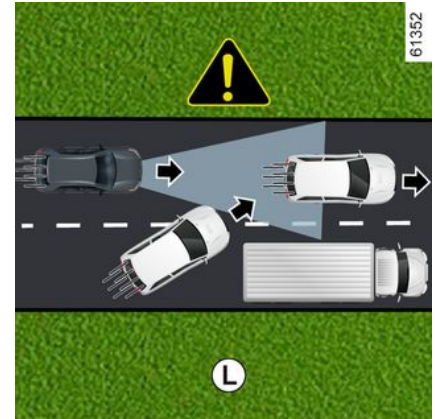

The system detects only vehicles (cars, trucks, motorbikes) that are moving in the same direction as your vehicle.

A vehicle turning into the same lane (e.g. **L**) will be taken into account by the system only once it enters the camera and radar detection areas.

The system may trigger inappropriate or delayed braking.

ADAPTIVE CRUISE CONTROL

3



The system cannot detect:

- vehicles arriving at intersections: slip road (e.g. **M**), etc.;
- vehicles driving on the wrong side of the road or reversing towards you.



The Stop and Go adaptive cruise control must be used outside built-up areas, on wide roads with visible lines.

Detection during cornering



When entering a corner or bend, the radar and/or camera may be temporarily unable to detect the vehicle in front (e.g. **N**).

The system may trigger an acceleration.

When exiting a bend, the system's detection of the vehicle in front may be disrupted or delayed.

The system may trigger inappropriate or delayed braking.

Detection of vehicles in adjacent lanes

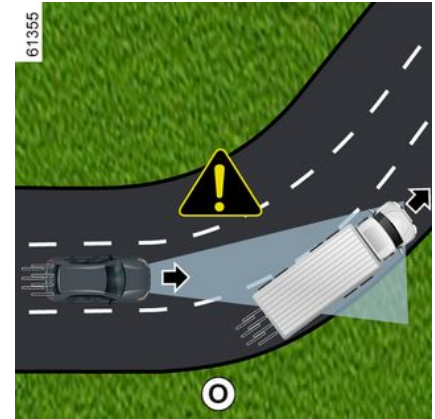

The system may detect vehicles driving on an adjacent lane when:

- you drive into a bend (e.g. **O**);
- you are driving on a road with narrow lanes;
- the speed of the vehicle on the adjacent lane is slower and if one of these vehicles is located too close to the lane of the other.

The system may incorrectly trigger vehicle slowing or braking.

ADAPTIVE CRUISE CONTROL

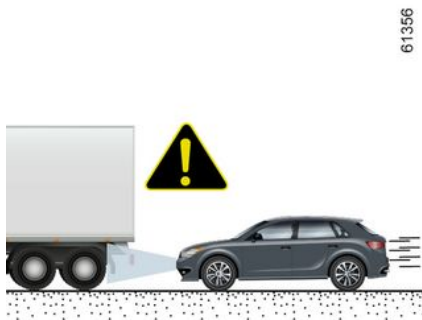

P

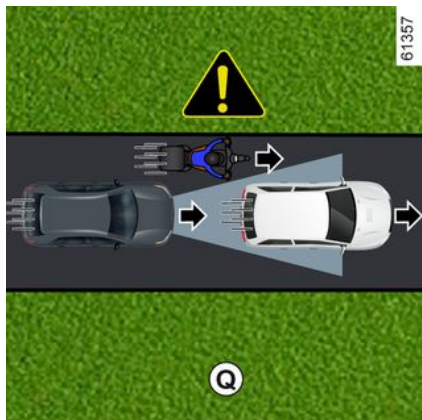

Vehicles hidden due to variations in ground relief

The system will not detect vehicles hidden due to variations in ground relief or those located outside of the camera and radar detection areas when driving uphill or downhill.

Vehicles outside the camera and radar detection areas.

The system will react late or not at all if the detected vehicles are outside the camera and radar detection areas, particularly in the following cases:

- vehicles transporting long objects which exceed the line;
- the actual length of tall vehicles (e.g. **P**) is outside the radar detection area (construction machine, agricultural equipment towing vehicle, etc.);
- vehicles insufficiently centred in the lane;
- narrow vehicles which are very close (e.g. **Q**).

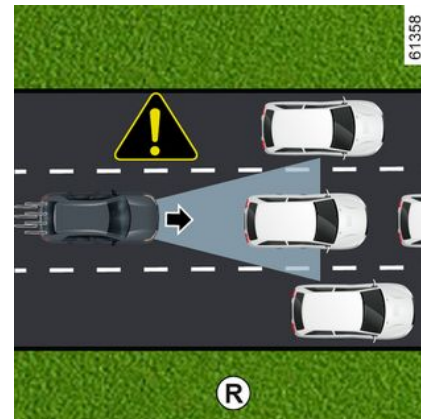

R

Stationary and slow moving vehicles

When your speed is over approximately 31 mph (50 km/h), **the system does not detect**:

- stationary vehicles (e.g. **R**);
- very slow moving vehicles.

When your speed is less than approximately 31 mph (50 km/h), **the system may not react or may react very late** to:

- stationary vehicles (e.g. **R**);
- very slow moving vehicles;

ADAPTIVE CRUISE CONTROL

3

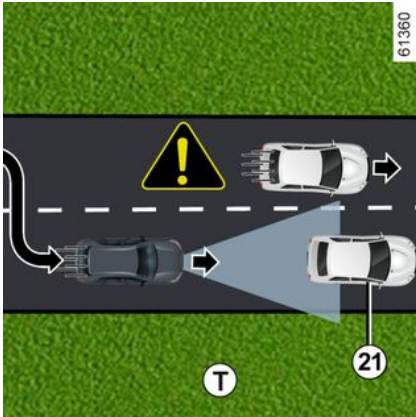
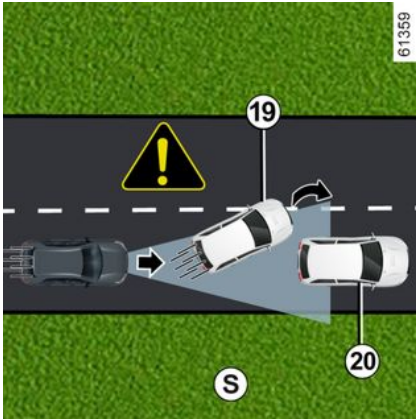

– vehicles in front **19** that change lane, discovering a stationary vehicle **20** (e.g. **S**);

– stationary vehicles **21**, when you change lane (e.g. **T**).



Always be ready to respond in all circumstances.

The driver must always be in control of the vehicle.

The Stop and Go adaptive cruise control does not trigger an emergency stop and its braking capability is limited.

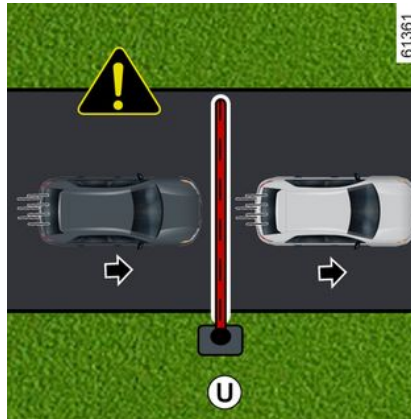

Non-detection of fixed obstacles and objects of a small size
The system cannot detect:

- pedestrians, bikes, scooters, etc.;
- animals;
- fixed obstacles (toll barriers, walls, etc.) (e.g. **U**).

These are not taken into account by the system. They do not trigger any alert or reaction by the system.

Detection of vehicles moving into lane at high speed

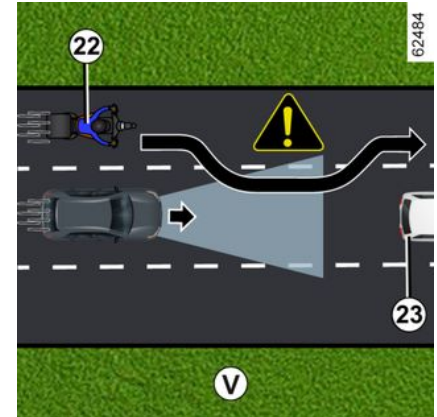

If your vehicle is overtaken by another vehicle driving at high speed **22** (motorcycle, car, etc.) and the vehicle is temporarily between you and the vehicle in front **23**, **the system may trigger undue acceleration, slowing or braking.**

ADAPTIVE CRUISE CONTROL

Warnings



This function is an additional driving aid. It can under no circumstances replace the driver's responsibility to respect speed limits and safe distances or to be vigilant.

The driver must always be in control of the vehicle.

Apart from the speed limit signs and road map information from the mapping (vehicles fitted with the "Road sign detection" function and a subscription), other traffic information (traffic lights, pedestrian crossings, etc.) is not taken into account by the system. The driver must always adapt their speed to the surroundings and driving conditions, regardless of system indications.

The system should under no circumstances be taken to be an obstacle detector or an anti-collision system.

Use the Stop and Go adaptive cruise control function outside built-up areas, on wide roads with visible lines.

System servicing/repairs

- In the event of an impact, the radar and/or camera alignment may be changed and its operation may consequently be affected. Deactivate the system and consult an authorised dealer.
- Any work in the proximity of the radar and/or camera (replacements, repairs, windscreen modifications, paintwork etc.) must be carried out by a qualified professional.

Only an authorised dealer is qualified to service the system.

ADAPTIVE CRUISE CONTROL



Deactivating the function

You must deactivate the function if:

- the vehicle is being towed (breakdowns);
- the vehicle is towing a trailer or a caravan;
- the vehicle is being driven in a tunnel or close to a metallic structure;
- the vehicle arrives at a toll point, a roadwork area or on a narrow lane;
- the vehicle is driven on a very winding road (mountain road, etc.);
- the vehicle is being driven up or down a very steep slope;
- the visibility is poor (glaring sun, fog, etc.);
- the vehicle is being driven on a slippery road surface (rain, snow, gravel, etc.);
- the weather conditions are poor (rain, snow, side winds, etc.);
- the radar area has been damaged (impacts, etc.);
- the camera area has been damaged (e.g. on the inside or outside of the windscreen);
- the windscreen is cracked or distorted.

In the event of the system behaving abnormally, deactivate it and consult an authorised dealer.

ADAPTIVE CRUISE CONTROL



In the event of system disturbance

Some conditions can disturb or damage the system's operation, such as:

- the windscreen or bumper is obscured in the radar area (by dirt, ice, snow, condensation, number plate, etc.);
- a complex environment (tunnel, etc.);
- poor weather conditions (snow, heavy rain, hail, black ice, etc.);
- poor visibility (night, fog, etc.);
- being dazzled (glaring sun, lights of vehicles travelling in the opposite direction; etc.);
- narrow, winding or undulating road (tight bends, etc.);
- a vehicle with a significant difference in speed;
- use of mats not adapted to the vehicle. On the driver's side, only use mats suitable for the vehicle, attached with the pre-fitted components, and check the fitting regularly. Do not lay one mat on top of another. **There is a risk of wedging the pedals.**

In this case, the system may brake or accelerate unintentionally.

Many unforeseen situations may affect the system operation. Certain objects or vehicles that can appear in the camera or radar detection zone may be interpreted by the system incorrectly, possibly leading to inappropriate acceleration or braking. **You should always be attentive to sudden events that might occur while you are driving. Always keep your vehicle under control by keeping your feet near the pedals, so that you are ready to act in any event.**

PARKING AIDS

Parking distance control

Operating principle

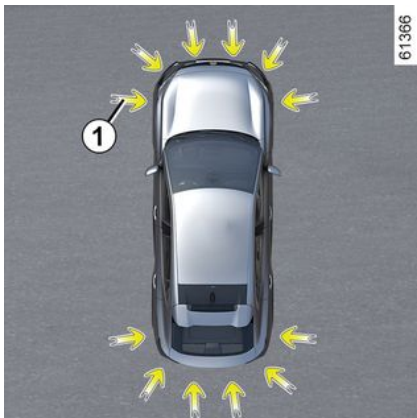

Ultrasonic sensors, indicated by arrows **1**, are fitted in the bumpers to detect obstacles near the vehicle.

The function alerts the driver via audible signals and a display representing the area where the obstacle was detected.

Depending on the equipment, the system detects obstacles behind, in front and to the sides of the vehicle.

The Park Assist system is only activated when the vehicle is driven at a speed below approximately 6 mph (10 km/h).

The function does not take into account towing or carrying systems that are not recognised by the system.



This function is an additional driving aid. Under no circumstances should it replace the driver's care or responsibility whilst reversing.

The driver should always be ready for sudden incidents while driving: always ensure that there are no small, narrow moving obstacles (such as a child, animal, pushchair, bicycle, stone, post, etc.) in the blind spot when manoeuvring.



An impact to the underside of the vehicle while manoeuvring (e.g. striking a post, raised kerb or other street furniture) may result in damage to the vehicle (e.g. deformation of an axle). To avoid any risk of accident, have your vehicle checked by an approved dealer.

Location of the ultrasonic sensors **1**

Ensure that the ultrasonic sensors indicated by the arrows **1** are not obscured (by dirt, mud, snow, a badly fitted/attached number plate, etc.), impacted, modified (including paintwork) or obstructed by any accessory fitted to the rear and/or, depending on the vehicle, to the front or sides of your vehicle.

Note: on vehicles equipped with the "360° camera" function → **282**, the analysis of the vehicle surroundings (zones **A** and **B**) is not displayed in the "Bird's eye view" or "Side view" mode.

PARKING AIDS

Operation

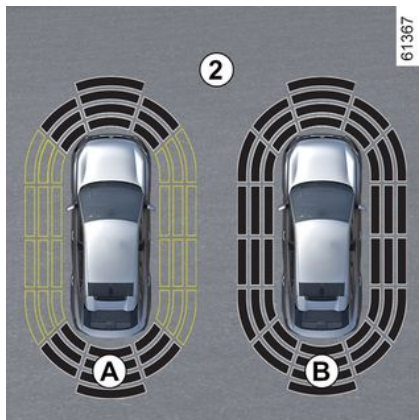

The display **2** shows the vehicle surroundings and emits beeps.

Depending on the equipment, it may be necessary to travel a few metres before the side detection is activated.

If all areas have a grey background, the whole area around the vehicle is being monitored:

- Display **A**: analysis of vehicle surroundings in progress;
- Display **B**: analysis of vehicle surroundings complete.

Obstacle detection

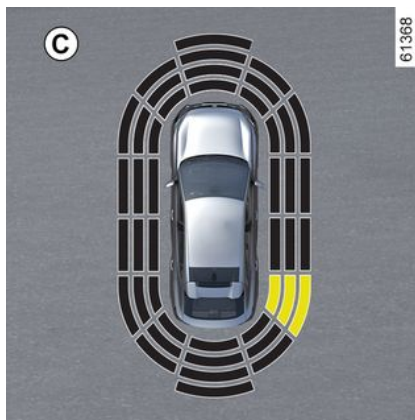

The system is able to detect most obstacles located near the rear and, depending on the vehicle, near the front and sides of the vehicle.

The audible signal frequency will increase as the vehicle approaches an obstacle, until it becomes a solid beep at approximately 20 cm for an obstacle detected on the sides and approximately 30 cm for an obstacle detected to the front or rear.

The area where the obstacle has been detected is displayed (display **C**). Depending on the vehicle, the area is displayed in green, orange (or yellow depending on the vehicle) or red, depending on the proximity of the detected obstacle.

i In the event of a change in trajectory during a manoeuvre, the risk of collision with an obstacle may be signalled late.

Special case of obstacles detected on the side

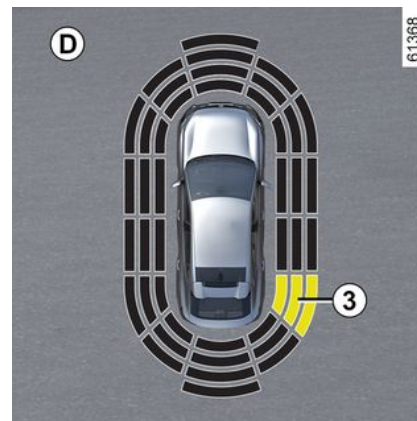

Depending on the direction of the wheels, the system determines the trajectory of the vehicle and notifies the driver if there is a risk or not of a collision with an obstacle **3** to the side of the vehicle.

If a side obstacle is detected:

- the beeps become faster and then sound continuously as the obstacle

PARKING AIDS

gets nearer. The area where the obstacle **3** has been detected is displayed (display **D**).

– if there is no risk of collision, no beep will sound when approaching the obstacle. Depending on the vehicle, the area where the obstacle **3** has been detected is shown interspersed.



In the event of a change in trajectory during a manoeuvre, the risk of collision with an obstacle may be signalled late.

Activation/deactivation

Activation/deactivation from the multimedia screen **4**



From the "Vehicle" world on your multimedia screen **4**, press the "Driving assistance" menu then "Parking".

Activate or deactivate areas covered by the ultrasonic detectors.

Please refer to the multimedia instructions for further information.

Note: depending on the vehicle, the rear detection zone cannot be deactivated.

Parking distance control automatic deactivation

The system is deactivated:

- when the vehicle speed is above approximately 6 mph (10 km/h);
- depending on the vehicle, when the vehicle is stationary for more than ap-

proximately five seconds and an obstacle is detected (such as when in a traffic jam, etc.);

- when you are in **N** or **P** position;
- when an operating fault is detected.

Note: depending on the vehicle, if the vehicle is fitted with a towbar recognised by the system, only the rear Park Assist function is deactivated.

Settings



For safety reasons, carry out any adjustments while the vehicle is stationary.



Each time the vehicle is started, the function resumes the activation status saved the last time the engine was stopped.

Adjusting settings from the multimedia screen **4**

PARKING AIDS



From the "Vehicle" world on your multimedia screen **4**, press the "Driving assistance" menu then "Parking".

Please refer to the multimedia instructions for further information.

Deactivating the system sound (depending on the vehicle)

Activate or deactivate the parking distance control sound.

Note: if you mute the sound, when approaching an obstacle you will be alerted only by the display.

Parking distance control audio volume

Adjust the Park Assist volume using the volume bar.



Each time the vehicle is started, the function resumes the activation status saved the last time the engine was stopped.

Special cases

You can manually deactivate sound alerts or, depending on the vehicle, the detection zone concerned in the event that:

- towing, carrying or trailer equipment that is unrecognised by the system is present in front of the ultrasonic sensors;
- the ultrasonic sensors are damaged.

Note: even if the sound is muted, the displays will continue to warn you.

Operating faults

When the system detects a malfunction: either a sound signal warns you for about three seconds when the reverse gear is engaged, accompanied by the "Check Parking sensors" message on the instrument panel, or the system does not produce a sound or display when the reverse gear is engaged.

Check that the ultrasonic sensors are clean.

If the fault persists, consult an approved dealer.

PARKING AIDS

Advice



When the vehicle is travelling at a speed below approximately 6 mph (10 km/h), some noises (motorcycle, lorry, pneumatic drill, etc.) may trigger the Park Assist system audible warnings.

3



System servicing/repairs

- In the event of an impact, the alignment of the ultrasonic sensors may be altered and its operation may consequently be affected. Deactivate the function and consult an authorised dealer.
- Any work in the area where the ultrasonic sensors are located (repairs, replacements etc.) must be carried out by a qualified professional.

Only an authorised dealer is qualified to service the system.

System disturbance

Some conditions can disrupt or damage the system operation, for example:

- poor weather conditions (rain, snow, hail, black ice, etc.);
- some types of noise (motorcycle, lorry, pneumatic drill, etc.);
- fitting an non-compatible towing ball or hook.

Risk of false alarms or absence of warnings

If the system behaves abnormally contact an authorised dealer.

Limitation of the system operation

- The area around the sensors must be kept clean and free of any modifications in order to ensure the proper operation of the system.
- Small objects moving close to the vehicle (motorcycles, bicycles, pedestrians, etc.) may not be recognised by the system.
- The system may not detect obstacles that are too close to the vehicle.
- The system may not provide a warning when the other vehicles or obstacles are travelling at a significantly different speed.
- When there is a change in trajectory during a manoeuvre, the system may be slow in reporting obstacles.

PARKING AIDS

Reversing camera

Operation

3



When the vehicle is reversing, the camera **1** on the tailgate transmits a view of the area surrounding the rear of the vehicle to the multimedia display **2** accompanied by one to three guide lines **3**, **4** and **5** (fixed, mobile and trailer guide lines).

This system uses several guidelines for its operation (mobile for trajectory and fixed for distance). When the red zone is reached, use the bumper image to stop accurately.



Fixed guide lines **3**

The fixed gauge includes coloured markers **A**, **B** and **C** indicating the distance behind the vehicle:

- **A** (red) at approximately 30 centimetres from the vehicle;
- **B** (yellow) at approximately 70 centimetres from the vehicle;
- **C** (green) at approximately 150 centimetres from the vehicle.

This gauge remains fixed and indicates the vehicle trajectory if the wheels are in line with the vehicle.

Moving guide line **4**

This is shown in blue on the multimedia screen **2**. It indicates the vehicle trajectory according to the position of the steering wheel.

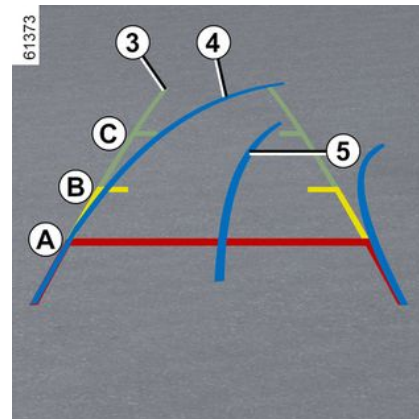

Trailer guide line **5**

This is shown in blue on the multimedia screen **2**. This indicates the trajectory of the trailer towbar according to the steering wheel position. It allows the driver to position the towbar as close as possible to the trailer's towing head.

Trailer view

In forward gear, if a trailer is attached, press the "Trailer" button from the "Vehicle" world on your multimedia screen **2** to enable the camera **1** to transmit a view of the area surrounding the rear of the vehicle during approximately 30 seconds.

PARKING AIDS

Settings



When the reverse gear is engaged, from the multimedia screen press the "Settings" button to add or remove the guide lines and adjust the camera image settings (brightness, contrast, etc.).

Please refer to the multimedia instructions for further information.



Make sure that the camera is not obscured (by dirt, mud, snow, condensation etc.).

"Zoom auto" function

If an obstacle is detected behind the vehicle, the function "Zoom auto" switches the current display to a top rear view.

To activate/deactivate the "Zoom auto" function, refer to the multimedia instructions.



The screen shows a reverse mirror image.

The frames are a representation projected on a flat surface. This information is to not be taken into account when superimposed on a vertical object or an object on the ground.

Objects which appear on the edge of the screen may be deformed.

In very bright light (snow, vehicle in sunshine, etc.), the camera vision may be adversely affected.

If the luggage compartment is open or incorrectly closed, the "Luggage compartment open" message appears.



This function is an additional aid. It cannot, therefore, under any circumstances replace the vigilance or the responsibility of the driver.

The driver should always be ready for sudden incidents while driving: always ensure that there are no small, narrow moving obstacles (such as a child, animal, pushchair, bicycle, stone, post, etc.) in the blind spot when manoeuvring.

PARKING AIDS

Difference between the estimated distance and actual distance

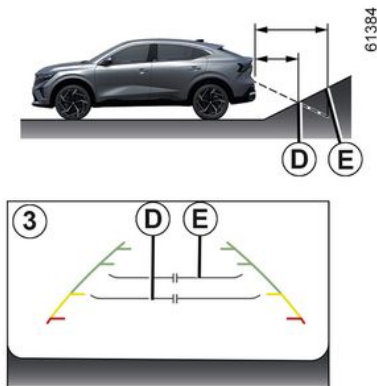

Driving or reversing towards a steep uphill slope

The fixed guidelines **3** show the distances as closer than they actually are.

The objects shown on the screen are actually further away on the slope.

For example, if the screen displays an object at **D**, the actual distance of the object is at **E**.

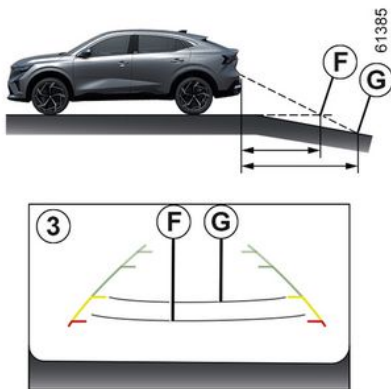

Driving or reversing towards a protruding object

The fixed guidelines **3** show the distances as further than they actually are.

Therefore, the objects shown on the screen are actually closer on the slope.

For example, if the screen displays an object at **G**, the actual distance of the object is at **F**.

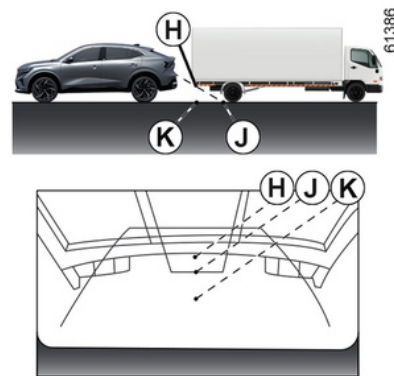

Driving or reversing towards a protruding object

Position **H** seems further than position **J** on the screen. However, position **H** is at the same distance as position **K**.

The trajectory indicated by the fixed and mobile guidelines do not take into account the height of the object. So there is a risk that the vehicle may collide with the object when reversing towards position **K**.

PARKING AIDS

Hands-free parking

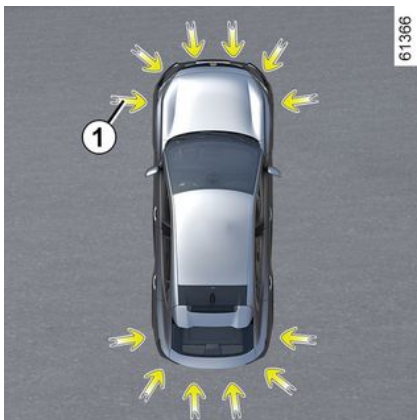

As indicated by the arrows **1**, the ultrasonic detectors installed in the vehicle bumpers help to find accessible parking spaces and assist the parking manoeuvre.

Remove your hands from the steering wheel, you only control:

- the accelerator pedal;
- the brake pedal;
- the gear lever.

At any time, you can regain control by using the steering wheel.

Switching on

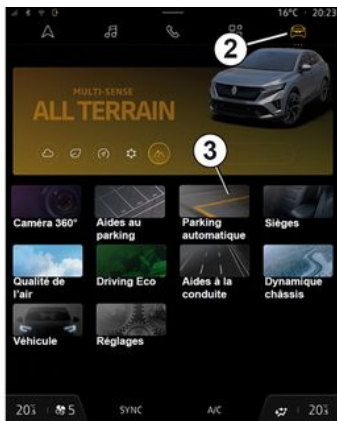

With the vehicle stationary or driving at less than approximately 19 mph (30 km/h), there are several ways to access the function:

- via the multimedia screen **4**, access the "Vehicle" world **2** and press the "Hands-free parking" **3** menu;
- via the "Hands-free parking" widget (if configured by the customer);
- via the "Favourites" button on the steering wheel (if configured by the customer);
- depending on the vehicle, via the "Hands-free parking" shortcut in the 360° camera view.

Special features



Ensure that the ultrasonic detectors indicated by the arrows **1** are not obscured (by dirt, mud, snow, a badly fitted number plate, etc.).

3

PARKING AIDS

Choice of manoeuvre

61392



3

The system can perform three types of manoeuvre:

- parallel parking **5**;
- perpendicular parking **6** ;
- moving out of a parallel parking space **7**.

From the multimedia screen **4**, select the manoeuvre to carry out.

Note: when starting the vehicle, or after having successfully completed parallel parking using the system, the default manoeuvre proposed by the system is assistance in exiting a parallel parking space.

In other cases, the default manoeuvre can be set from the multimedia screen **4**.

Please refer to the multimedia instructions for further information.



The system start up is accompanied by activation of the parking distance control and, on those vehicles equipped, the reversing camera or 360° camera to help the driver visualise the manoeuvre → **268**, → **274**, → **282**.

Operation

61393



Parking

As long as the vehicle speed is less than 19 mph (30 km/h), the system looks for available parking spaces on both sides of the vehicle.

Once a space has been found, it is displayed on the multimedia screen **4**, indicated by the letter "P". Drive slowly until the "STOP" message appears, accompanied by a beep. If more than one space is detected, you must select the desired space by touching the screen.

The space turns green on the multimedia screen **4** and is marked with the letter "P".

- Stop the vehicle;
- select reverse gear.

The indicator light  lights up on the instrument panel and a beep sounds.

- Let go of the steering wheel;
- follow the system instructions on the multimedia screen **4**.

Your speed should not exceed around 4 mph (7 km/h).

Once the warning light  on the instrument panel goes off and a beep sounds, the manoeuvre has been completed.

PARKING AIDS



This function is an additional driving aid. Therefore, it can under no circumstances replace the driver's vigilance and responsibility during manoeuvres (the driver must always be ready to brake).

Exiting a parallel parking space

- Activate the "Hands-free parking" function;
- select the "Exit parallel parking space" mode;
- activate the direction indicator lights on the side on which you wish to exit the vehicle;

If all conditions are met, a message will appear on the multimedia screen 4 to start the manoeuvre.

- press "OK" to start.

The indicator light  lights up on the instrument panel and a beep sounds.

- let go of the steering wheel;
- carry out forward and backward manoeuvres following the instructions shown on the multimedia screen 4 and using the alerts provided by the Park Assist system.

Your speed should not exceed around 4 mph (7 km/h).

Once the vehicle is in a position to exit the parking space, the warning light



disappears from the instrument panel accompanied by a beep and a message appears on the multimedia screen 4 to confirm that the manoeuvre is complete.



When manoeuvring, the steering wheel may turn quickly: do not put your hands inside and make sure that nothing is caught inside.

Suspending/resuming the manoeuvre

The manoeuvre is suspended in the following cases:

- you take control of the wheel;
- the vehicle is stationary for too long;
- an obstacle in the direction of movement prevents the manoeuvre from being completed;
- the engine stops;
- a door or the luggage compartment is opened.

The warning light  warning light disappears from the instrument panel accompanied by a beep to inform you that the manoeuvre has been suspended. The reason for suspending the manoeuvre will be displayed on the multimedia screen 4.

Make sure:

- you have let go of the steering wheel;
- and
- that all doors and the luggage compartment are closed;
- and
- that no obstacles are in the way of the direction of movement;
- and
- that the engine is started.

If the  flashes, this indicates that the system is once again available to resume the manoeuvre.

To resume the manoeuvre, press the "Parking aids" menu. The warning light



appears on the instrument panel.

Follow the instructions shown on the multifunction screen 4.

PARKING AIDS

Cancelling the manoeuvre

The manoeuvre is cancelled in the following cases:

- you take control of the wheel;
- the vehicle speed has exceeded 4 mph (7 km/h);
- by pressing the button **8**;
- you have performed more than ten forwards/backwards movements in one manoeuvre;
- the parking distance control sensors are dirty or obscured;
- the manoeuvre has been suspended for too long.

The  warning light disappears from the instrument panel accompanied by a beep to warn you that the manoeuvre has been aborted. The reason for cancelling the manoeuvre will be displayed on the multimedia screen **4**.

Function unavailable

When you select one of the system activation methods, if the operating conditions are not met, the "Hands-free parking unavailable" message appears on the multimedia screen to inform you that the function is unavailable.

Operating faults

When the function detects an operating fault, the following messages are displayed on the instrument panel:

- "Check Park Assist", accompanied

by the warning light ;

or

- "Check parking sensors";

or

- "Check Parking Aids".

Clean the ultrasonic sensors. If there is still a problem, contact an approved dealer.

Note: if there is a fault with the function, the vehicle is not immobilised.

Take control of the vehicle again immediately.

PARKING AIDS

Warnings



This function is an additional driving aid. This function is not under any circumstances intended to replace the due care and attention of the driver, who should at all times be in control of the vehicle. Make sure that the manoeuvre complies with the applicable traffic regulations in your location.

The driver should always be ready for sudden incidents while driving: always ensure that there are no small, narrow moving obstacles (such as a child, animal, pushchair, bicycle, stone, post, towing equipment, etc.) in the blind spot when manoeuvring.

System servicing/repairs

- In the event of an impact, the alignment of the sensors may be changed and their operation may consequently be affected. Deactivate the function and consult an authorised dealer.
- Any work in the area where the sensors are located (repairs, replacements, exterior trim modifications, etc.) must be carried out by a qualified professional.

Only an authorised dealer is qualified to service the system.

In the event of system disturbance

Certain conditions may disrupt or impair operation of the system, such as poor weather conditions (snow, hail, ice, etc.).

In the event of the system behaving abnormally, deactivate it and consult an authorised dealer.

Risk of erroneous false alarms.

Limitations of the system operation

- The system cannot detect objects located in the sensor blind spots.
- Always visually check that the parking space proposed by the system is still available and contains no obstacles.
- The system must not be used when towing a trailer or when there is a towing or load carrying system on the vehicle or on surrounding vehicles.

PARKING AIDS

360° camera

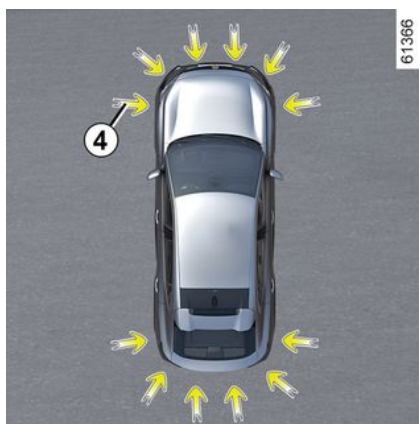
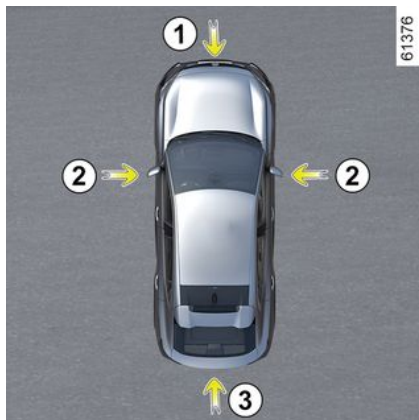

Using information from cameras **1**, **2** and **3** located in the front bumper, door mirrors and on the tailgate, as well as ultrasonic detectors **4** located in the vehicle bumpers, the feature assists with difficult manoeuvres (e.g. parking) by displaying the vehicle surroundings.

Note: make sure that the cameras are not obscured (by dirt, mud, snow, condensation, etc.).

Operation



The cameras transmit several separate views to the multimedia screen **5**. They enable you to view the vehicle surroundings:

- front view (using camera **1**): standard front view and panoramic front view;
- rear view (using camera **3**): standard rear view and panoramic front view;
- bird's eye view (using cameras **1**, **2** and **3**): standard bird's eye view and pop-up bird's eye view (when an obstacle is detected);
- side view (using camera **2**): front side view and rear side view;
- 3D view;
- trailer view.

The ultrasonic detectors detect obstacles at the front, rear and (depending on the vehicle) side of the vehicle.

PARKING AIDS

Front camera 1



The front camera view is displayed on the multimedia screen **5**.



This function is an additional aid. It cannot, therefore, under any circumstances replace the vigilance or the responsibility of the driver.

The driver should always be ready for sudden incidents while driving: always ensure that there are no small, narrow moving obstacles (such as a child, animal, pushchair, bicycle, stone, post, etc.) in the blind spot when manoeuvring.

Rear camera 3

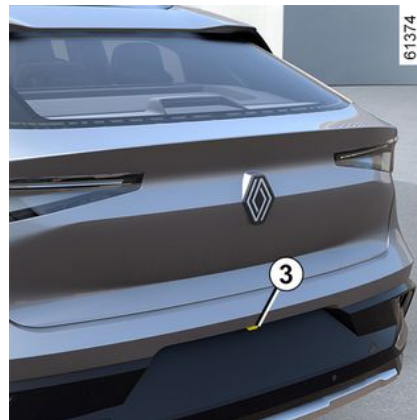

The rear camera view is displayed on the multimedia screen **5**.

3

PARKING AIDS

i For the rear views, the multimedia screen **5** shows a reverse image of the rear view as in a rear view mirror.



In front view or rear view: when manoeuvring on a slope, objects shown on the multimedia screen may be closer or further away than they seem.

Take this into account in order to correctly assess the distance before any manoeuvre.

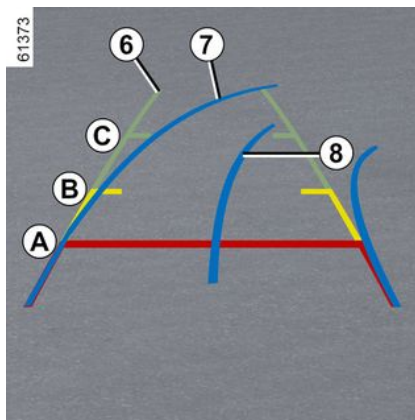

The "front" or "rear" view transmitted to the multimedia screen **5** is displayed with one, two or three guide lines **6**, **7** and **8**.

This system is initially used with the aid of several gauges (mobile for trajectory and fixed for distance).

Fixed guide lines **6**

The fixed gauge includes coloured markers **A**, **B** and **C** indicating the distance behind the vehicle:

- **A** (red) at approximately 30 centimetres from the vehicle;
- **B** (yellow) at approximately 70 centimetres from the vehicle;
- **C** (green) at approximately 150 centimetres from the vehicle.

Moving guide line **7**

This is shown in blue on the multimedia screen **5**. It indicates the vehicle trajectory according to the position of the steering wheel in the front and the rear view.

Trailer guide line **8**

This is shown in blue on the multimedia screen **5**. This indicates the trajectory of the trailer towbar in relation to the steering wheel position.

It allows the driver to position the towbar as close as possible to the trailer's towing head.



The front, rear and side view guidelines are a representation projected onto flat ground; this information must not be taken into account when superimposed on a vertical object or an object on the ground.

Objects displayed on the edge of the multimedia screen may appear distorted.

In very bright light (snow, vehicle in sunshine, etc.), the camera vision may be adversely affected.

PARKING AIDS



In the combined representation from the cameras:

- raised objects (pavement, vehicle, etc.) may appear distorted in the bird's eye view;
- any objects on top of the vehicle are not displayed.

Front side camera 2

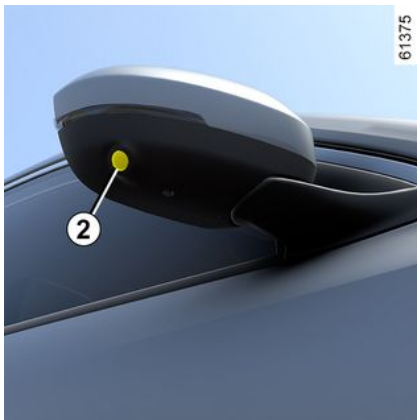

Camera 2, fitted in the door mirror, transmits a side view to the multimedia screen 5.

Depending on the vehicle, you can use the multimedia screen to change the

bird's eye view to the front side view. Please refer to the multimedia instructions for further information.

Bird's eye view



The bird's eye view is a combined representation from cameras 1, 2 and 3. It displays a view of the top of the vehicle and its surroundings.

This can be used to confirm a view of the vehicle position in relation to its immediate surroundings (front, rear and side).



In "bird's eye view" mode, the objects displayed on the multimedia screen are actually further away than they seem. **Take this into account in order to correctly assess the distance before any manoeuvre.**

Side views

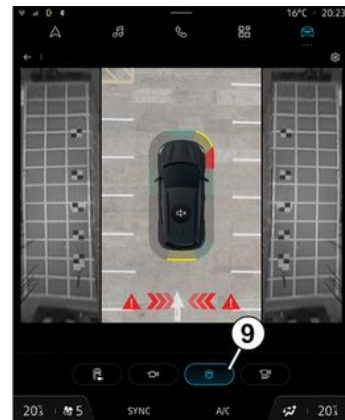

On the multimedia screen, press the dedicated button 9 for a view combining a bird's eye view and two side views.

PARKING AIDS

Front panoramic view or rear panoramic view

3

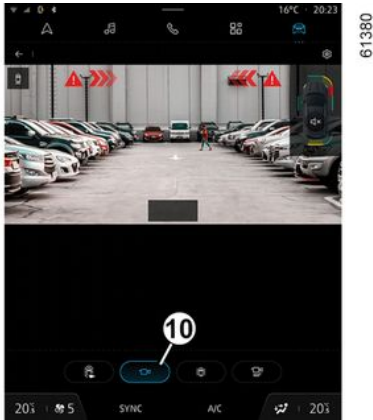

On the multimedia screen, press the dedicated button **10** for a panoramic front view.

When reverse gear is engaged, the front panoramic view is replaced by a rear panoramic view.

Note: the front view or the rear view varies depending on the steering wheel angle, in order to improve the driver's vision.

3D view



On the multimedia screen, press the dedicated button **11** to obtain a three-dimensional 3D view of the vehicle and its surroundings.

Trailer view



In forward gear, if a trailer is attached, press the "Trailer" button from the "Vehicle" world on your multimedia screen **5** to enable the camera **3** to transmit a view of the area surrounding the rear of the vehicle during approximately 30 seconds.

PARKING AIDS

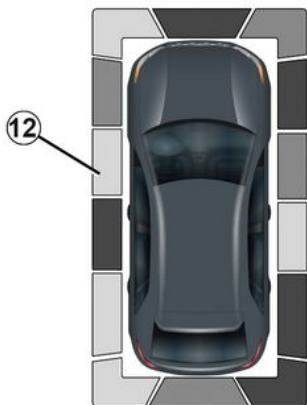

61448

- yellow: obstacle between approximately 30 and 50 centimetres;
- red: obstacle within approximately 30 centimetres.

These indicators also show the locations where obstacles are detected, as indicated by their positions in relation to the "Vehicle" symbol.

For more information please see → 268.

"Auto zoom" function

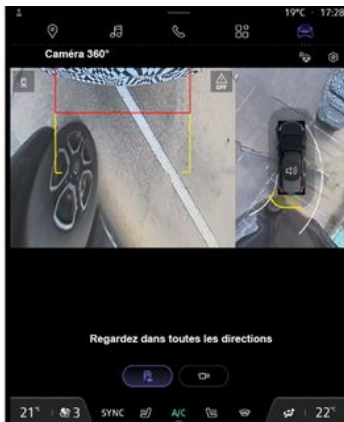

If an obstacle is detected in the vicinity of the front or rear of the vehicle, the "Zoom auto" function switches the current display to a specific display (top, front or rear view).

From the multimedia screen, when the "360° camera" system is displayed, you can change the views (e.g. replace the rear view by the panoramic rear view).

Obstacle detection

While the system is activated, if the "Park Assist" function detects one or more obstacles around the vehicle, the indicator **12** is displayed on the various views.

In addition to the audible warning, these indicators show the proximity of obstacles via different colours:

- green: obstacle between approximately 50 and 70 centimetres;

To activate or deactivate the "Zoom auto" function, please refer to the multimedia instructions.

Activation/deactivation



Automatic mode

With the vehicle stationary and the engine running, automatic mode is activated when the reverse gear is engaged. The rear view and the bird's eye view appear on the multimedia screen **5**.

When the reverse gear is quickly shifted to forward gear, the rear view and bird's eye view are replaced by the front view and bird's eye view on the multimedia screen **5**.

PARKING AIDS

Automatic mode is deactivated:

- after approximately three seconds, when shifting from reverse gear to neutral position (on vehicles equipped with a manual gearbox) or into **N** or **P** position (on vehicles equipped with an automatic gearbox);
- after approximately three minutes, if making several movements forwards/backwards (e.g. when manoeuvring), before moving the lever into neutral position (on vehicles with a manual gearbox) or into **N** or **P** position (on vehicles with an automatic gearbox);
- when the vehicle speed moving forwards exceeds approximately 7 mph (12 km/h) in a forward gear or in reverse gear.

Manual mode

To activate manual mode, with the vehicle stationary and the engine on, from the "Vehicle" world on your multimedia screen **5**, press the "360° camera" menu to display the front view and bird's eye view on the multimedia screen.

Manual mode is deactivated:

- when the vehicle speed reaches approximately 7 mph (12 km/h) in a forward gear or in reverse gear;
- when the gear lever has not been used for approximately three minutes.



- Do not use this function while the door mirrors are in folded position.
- Ensure that the luggage compartment door is properly closed before using the function.
- Do not place any objects on or in front of the cameras.

Difference between the estimated distance and actual distance

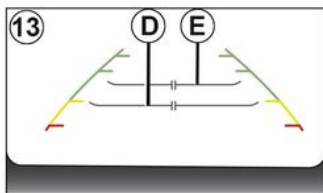

The fixed guidelines **13** show the distances as closer than they actually are.

The objects shown on the screen are actually further away on the slope.

For example, if the screen displays an object at **D**, the actual distance of the object is at **E**.

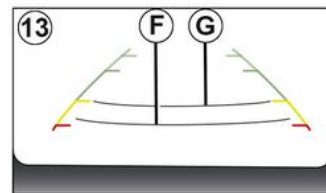

Driving or reversing towards a steep downhill slope

The fixed guidelines **13** show the distances as further than they actually are.

Therefore, the objects shown on the screen are actually closer on the slope.

For example, if the screen displays an object at **G**, the actual distance of the object is at **F**.

PARKING AIDS

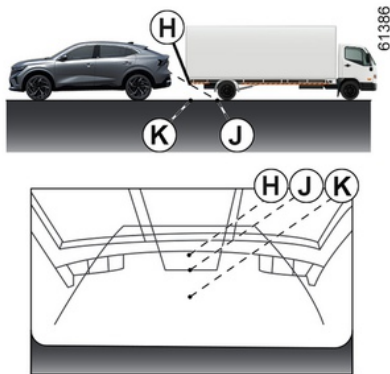

Driving or reversing towards a protruding object

Position **H** seems further than position **J** on the screen. However, position **H** is at the same distance as position **K**. The trajectory indicated by the fixed and mobile guidelines do not take into account the height of the object. So there is a risk that the vehicle may collide with the object when reversing towards position **K**.

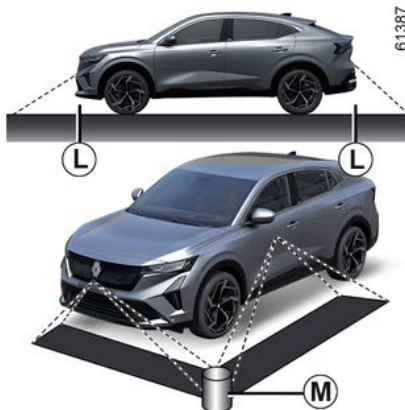

Limitation of the system operation

The system is unable to display objects located in certain areas.

In the front or rear view mode, the system cannot be used to view an object in area **L**.

In bird's eye view mode, the system cannot be used to view a large object in area **M** (near the edge of the displayed area).

Adjusting the display



From the multimedia screen, when the "360° camera" system is displayed, you can change the views (e.g. replace the rear view by the panoramic rear view).



For safety reasons, carry out any adjustments while the vehicle is stationary.

If the gear lever is in **R** position (on an automatic gearbox) or in reverse gear (on a manual gearbox), the following views are available:

PARKING AIDS

- screen split between the rear view/ bird's eye view;
- or
- panoramic rear view;
- or
- side views/bird's eye view (depending on the vehicle);
- or
- 3D view (depending on the vehicle).

When shifting from reverse gear to **P** position (on an automatic gearbox) or to neutral position (on a manual gearbox), the following views are available:

- screen split between the rear view and the bird's eye view;
- or
- panoramic rear view (depending on the vehicle);
- or
- side views/bird's eye view (depending on the vehicle);
- or
- 3D view (depending on the vehicle).

When shifting from reverse gear to **D** position (on an automatic gearbox) or to any gear (on a manual gearbox), the following views are available:

- screen split between the front view and the bird's eye view;
- or

- front panoramic view;
- or
- side views/bird's eye view;
- or
- 3D view.

Adjusting the camera settings

From the multimedia screen, while the "360° camera" system is displayed, press the "Settings" button to add or remove guide lines and adjust the camera image parameters (brightness, contrast, etc.).

Please refer to the multimedia instructions for further information.

Note: for safety reasons, the views are not displayed on the "Settings" menu while the vehicle is moving.

Parking exit warning





Using information from the radars installed on each side of the rear bumper (zone **A**), the system notifies the driver when another vehicle appears in the detection zone **B**.

The function is activated if:

- the reverse gear is engaged;
- and
- the vehicle is stationary or driving at a low speed.

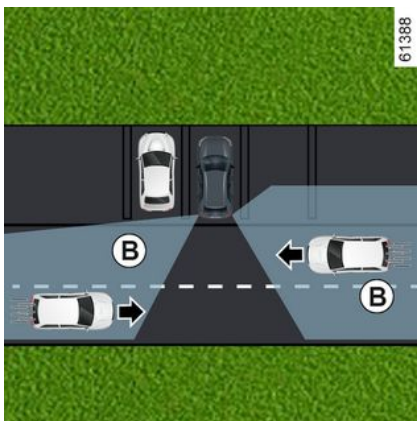
PARKING AIDS



 The system's detection capability depends on the vehicle's surroundings (static objects etc.) and the condition of the bumper etc.

 This function is an additional driving aid. This function is not under any circumstances intended to replace the due care and attention of the driver, who should at all times be in control of the vehicle.

Special feature

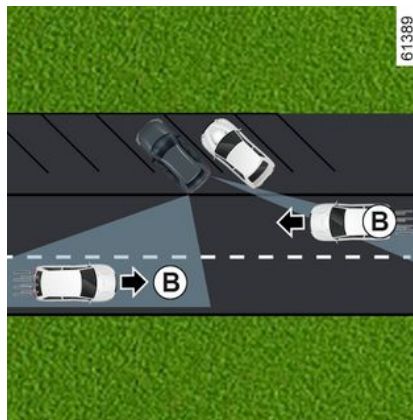

Make sure that the radar area **A** is not obscured (by stickers, mud, snow, etc.).

If one of the radars is obscured, the "Side radars without visibility" message is displayed on the instrument panel. Clean the area where the sensors are located.

Activation/deactivation from multimedia screen 1

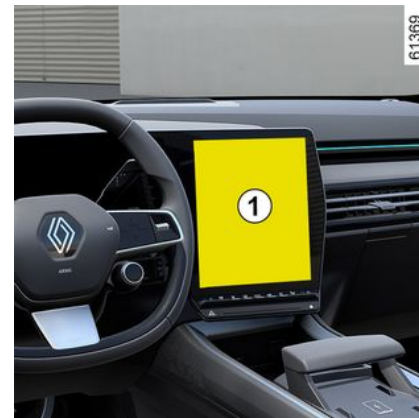

To activate or deactivate the function, refer to the multimedia instructions. Select "ON" or "OFF".

PARKING AIDS

Operation



The function warns you if a vehicle is in area **B** and is approaching your vehicle.

When a vehicle is detected, the warning lights **2** light up on both door mirrors **3**.

Note: clean the door mirrors regularly **3** so that the warning lights **2** can be seen.

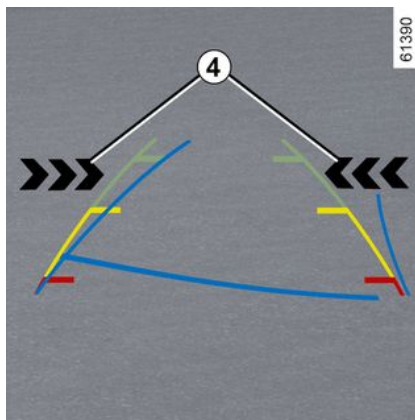

The warning lights **4** on the multimedia screen indicate the side on which the approaching vehicle has been detected.

Note: clean the camera regularly so that it is not obscured.

Warning lights **2** and **4** are accompanied by an audible warning when reverse gear is engaged and your vehicle is moving.

If the vehicle is fitted with a towbar recognised by the system and a trailer has been connected, the parking exit warning is automatically deactivated. The "Driving assist unavailable" message is displayed on the instrument panel to warn you.

Operating faults

If the vehicle is fitted with a towbar recognised by the system and a trailer has been connected, the parking exit warning is automatically deactivated and the following message is displayed on the instrument panel: "Driving aids unavailable".

When the system detects a fault, the "Check side radars" message is displayed on the instrument panel. Consult an approved dealer.



Due to the presence of sensors behind the bumper, it is advisable to entrust any operation on the bumper (repair, replacement, paintwork, etc.) to a qualified professional.

PARKING AIDS

Limitations to system operation



Limitation of the system operation

- The radar area should be kept clean and free of any modifications in order to ensure the proper operation of the system.
- Small objects (motorcycles, bicycles, pedestrians etc.) moving towards to the vehicle may not be recognised by the system.

Deactivating the function

You must deactivate the function if:

- the radar area **A** has been damaged (rear bumper);
- the vehicle is fitted with a towbar that is not recognised by the system.

PARKING AIDS

Warnings



This function is an additional driving aid. This function is not under any circumstances intended to replace the due care and attention of the driver, who should at all times be in control of the vehicle.

The system should under no circumstances be taken to be an obstacle detector or an anti-collision system.

System servicing/repairs

- In the event of an impact, the position of the radars may be changed, affecting the function. Deactivate the function and consult an authorised dealer.
- Any work in the area where the radars are located (repair, replacement, bodywork etc.) must be carried out by a qualified professional.

Only an authorised dealer is qualified to service the system.

System disturbance

Some conditions can disrupt or damage the system operation, for example:

- a complex environment (underground car park, metallic structures, etc.);
- poor weather conditions (snow, heavy rain, hail, black ice etc.).

Risk of false alarms or absence of warnings

In the event of the system behaving abnormally, deactivate it and consult an authorised dealer.

PARKING AIDS

Safe passenger exit

Description

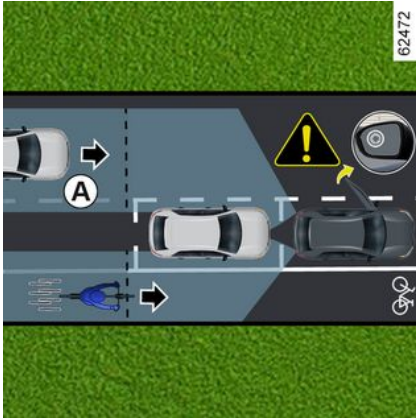

This function is an additional driving aid for the safety of the occupants of the vehicle.

The purpose of the "Safe passenger exit" function is to warn the driver and/or passengers of the potential danger if they open their doors when the vehicle is stationary.

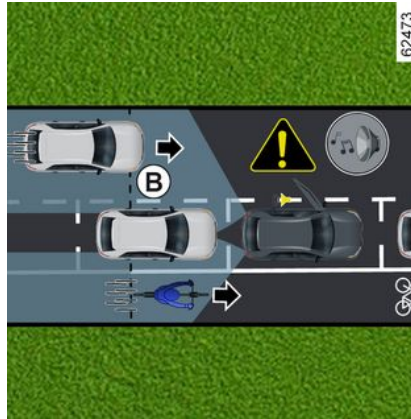

Using information from the sensors installed on each side of the rear bumper (area **C**), the function warns the driver:

- when another vehicle (or motorcycle, bicycle, pedestrian, etc.) is within the detection zone **A**;
- and
- when there is a risk of collision with a vehicle (or motorcycle, bicycle, pedestrian, etc.) in the zone **B**.

Special feature



Ensure that zone **C** around the radars on each side of the rear bumper are not obstructed (by dirt, mud, snow, etc.).

If one of the radars is obscured, the "Side radars without visibility" message is displayed on the instrument panel. Clean the area where the sensors are located.

You must deactivate the function if:

- the radar zone **C** has been damaged (rear bumper);
- the vehicle is fitted with a towbar that is not recognised by the system.

PARKING AIDS

Operation



When a door is opened, when a moving object is detected, the warning light **1** is displayed on the door mirror **2** and, depending on the vehicle, the ambient lights in the front door are illuminated.

Note: clean the door mirrors **2** regularly so that the warning light **1** can be seen.



When the detected object is very close, a beep will sound, along with the warning message "Lateral obstacle detected" **3** on the instrument panel.

Note: the system remains active for some time after the ignition has been switched off.

Activating/deactivating the function from the multimedia screen **4**



To activate or deactivate the function, refer to the multimedia instructions.

 When the vehicle is unlocked, the function returns to the last saved status on the multimedia screen.

Conditions for non-function

- the vehicle is moving and is not completely stationary;
- the vehicle is locked from the outside;

PARKING AIDS

- there are moving objects (motor-bikes, bicycles, pedestrians, vehicles, etc.) moving towards or near your vehicle at a low speed that is not considered a risk by the system;
- the range of the sensors located inside the rear bumper is hidden by objects, such as other particularly wide parked vehicles those parked very close to your vehicle.

If the vehicle is equipped with a towbar recognised by the system, the "Driving aids unavailable" message is displayed on the instrument panel to inform you that the function is not operational.

For information on the range of equipment adapted to your vehicle, we advise you to consult an approved Dealer.

Operating faults

When the system detects a fault, the "Check side radars" message is displayed on the instrument panel. Consult an approved dealer.



This function is an additional driving aid and may not detect certain vehicles or objects in

movement in the vicinity of your vehicle. This function is not in any way a substitute for the vigilance and responsibility of the driver and the occupants of the vehicle, who are always responsible for paying particular attention to the traffic situation and checking the area before leaving the vehicle.

In the event of system disturbance

Certain conditions (complex environment, poor weather conditions, etc.) may disrupt or damage the operation of the system, with the risk of false alarms.

EMERGENCY CALL

If the vehicle is equipped, the emergency call function can be used to call the emergency services (without charge) automatically or manually in the event of an accident or illness, reducing the time it takes for the emergency services to arrive.

Note: the emergency call function is operational:

- in countries covered by the telematics services and infrastructure associated and compatible with the system;
- depending on the network coverage in the geographical region where the vehicle is being driven.

If you use the emergency call function to report an accident which you have witnessed, this implies stopping where traffic conditions allow in order for the emergency services to locate your vehicle and therefore the location of the reported accident.

In all cases, comply with local legislation.



Use the emergency call only in the event of an emergency you are involved in, if you witness an accident or if you feel ill.

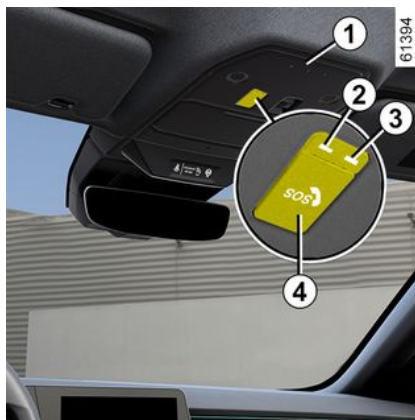

1. Microphone.
2. System operation/fault warning light:
 - red: operation fault.
3. System operation warning light:
 - green: operational (network available);
 - off: non-operational (e.g. network unavailable);
 - flashing green: call in progress.
4. Switch.
5. Speaker.



A call always takes place as follows:

- the call is initiated with the emergency services;
- data related to the incident (manufacturer's plate, time of the call, last locations, vehicle direction, etc.) is sent;
- voice communication takes place with the emergency services;
- if necessary, emergency assistance is called.

There are two emergency call modes:

- automatic mode;
- Manual mode.

Automatic mode

The emergency call starts automatically in the event of an accident that has

EMERGENCY CALL

triggered activation of the protective equipment (seat belt pretensioners, airbag, etc.).



In the event of an accident, if the location and traffic conditions permit, stay close to the vehicle in order to be able answer the call centre quickly if necessary.

Manual mode



To make a call manually:

- briefly press the flap **4**;
- guide it downwards;
- press button **6** "SOS".

If the button was pressed by mistake, it is possible to cancel the call by pressing and holding the button **6** for around two seconds, before the call is connected to the call centre.

Once a call is established, only the call centre can end it.

Operating faults



In some cases, the emergency call may not work (e.g. low battery, etc.).

When the system detects an operating fault, the warning light **2** appears in red for over 30 minutes. Consult an approved dealer as soon as possible.



The system operates with a dedicated battery. The battery service life is approximately four years (the warning light **2** appears in red to warn you).

Consult an approved dealer.



To guarantee your safety and the proper operation of the system, any operation carried out on the battery (removal, disconnection, etc.) must be carried out by a qualified specialist.

Risk of serious burns or electric shocks.

You must respect the replacement intervals (without exceeding them) as stated in the maintenance document.

The battery is a specific type. Please ensure it is replaced with the same type.

Call an approved dealer.

EMERGENCY CALL



Without the emergency call feature, the system is not trackable and will not be under constant surveillance. Data is automatically and constantly erased, and the system stores only the last three positions of the vehicle.

According to local legislation, data is only sent in the event of an emergency call. Data sent to the call centre is treated according to the personal data protection laws applicable in the country where you are located. The system stores activity history data for 13 hours only.

The vehicle owner has the right of access to their data. They can request that the data be corrected, deleted or locked.

MULTI-SENSE

Depending on the vehicle, the Multi-Sense system provides a choice of several driving modes that influence the driving, ambient lighting and comfort:

- all the modes are preconfigured and can be customised (ambient lighting, etc.);
- the Perso mode is customisable.

Depending on the vehicle, the driving modes can act on:

- steering force;
- the Electronic Stability Program;
- variable suspension ➔ 193;
- the four-wheel drive ➔ 192;
- the response of the engine and gearbox.

They also influence:

- the lighting in the passenger compartment and on the instrument panel;
- the presentation of the instrument panel and the multimedia screen.



The engine settings are specific to each of the driving modes and, with the exception of the Perso mode, they cannot be adjusted.

Accessing the menu



Depending on the vehicle, you can access "Multi-Sense":

- from the multimedia screen 1;
- using the steering wheel control 2.

Please refer to the multimedia instructions for further information.

Eco mode

The Eco mode focuses on energy saving. Managing the engine, gearbox and heating level enables the consumption to be reduced ➔ 178.

If equipped, the "Chassis control" suspension is very supple (the Comfort setting is the default setting) ➔ 193.

Spot mode

This mode enables an increased responsiveness from the engine and the gearbox. The steering is firmer.

If equipped, the "Chassis control" suspension is very rigid (the Sport setting is the default setting) ➔ 193.

Comfort mode

Using standard vehicle settings, this mode gives you the best compromise between comfort and dynamism.

If equipped, the "Chassis control" suspension is very supple (the Comfort setting is the default setting) ➔ 193.



After the engine is switched off, the vehicle will always restart in Comfortmode.

Custom mode

This mode allows the complete configuration of the driving elements, including engine responsiveness.

Snow mode

This mode offers optimal performance for controlling the vehicle on snowy ground.

MULTI-SENSE

If equipped, the "Chassis control" suspension is very supple (the Comfort setting is the default setting) ➔ **193**.

4

AIR VENTS, HEATING AND AIR CONDITIONING

Air vents: air outlets

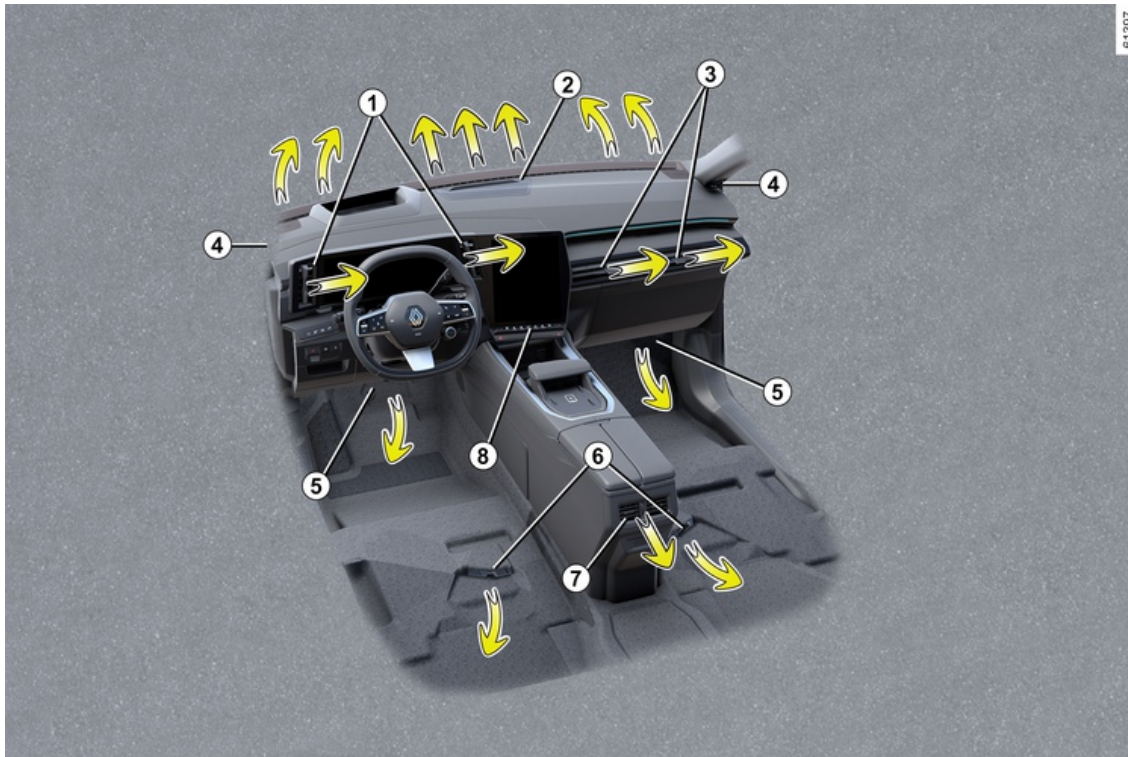

4

AIR VENTS, HEATING AND AIR CONDITIONING

1. Driver's position air vents
2. Windscreen demister outlet
3. Passenger air vents
4. Side window demister outlet
5. Footwell heater outlets for front passengers
6. Footwell heater outlets for rear passengers
7. Rear passenger central air vents.
8. Control panel

AIR VENTS, HEATING AND AIR CONDITIONING

Driver's position air vents 1



Direction

To direct the air flow, turn the air vents **1** using the tabs **9**.

To close: move the tab **10** away from the steering wheel beyond the point of resistance.

To open: move the tab **10** towards the steering wheel.

Passenger air vents 3

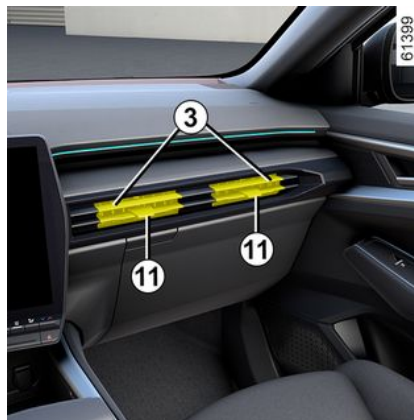

Direction

To direct the air flow, turn the air vents using the tabs **11**.

To close: move the tab **11** towards the outside of the front panel, beyond the point of resistance.

To open: move the tab **11** towards the inside of the front panel.



Do not attach any objects to the air vents (e.g. telephone mounting).

Risk of damage.



Air flow

To control the air flow from the air vents **1** and **3**, press or raise the control **12** to the level desired.

To remove bad odours from your vehicles, only use the systems designed for this purpose. Consult an approved dealer.



Do not add anything to the vehicle's ventilation circuit (for example, to remove bad odours).

There is a risk of damage or of fire.

AIR VENTS, HEATING AND AIR CONDITIONING

Rear seats



(depending on the vehicle)

Direction

To direct the air flow, turn the air vents **7** using the tabs.

Air flow

To check the flow of the air vents **7** turn the knob **13** according to the desired opening:

- to the right: maximum air flow;
- to the left: closed.



Do not attach any objects to the air vents (e.g. telephone mounting).

Risk of damage.



Do not add anything to the vehicle's ventilation circuit (for example, to remove bad odours).

There is a risk of damage or of fire.

Automatic climate control

The controls



1. Driver's heating temperature indicator.
2. Ventilation speed indicator.
3. Activation control for the "Synchronisation" SYNC function (configuration **A**).

4. Driver's heated seat activation control.

5. Air-conditioning activation control.

6. Passenger's heated seat activation control.

7. Heated steering wheel activation control.

8. Passenger compartment air distribution indicator.

9. Passenger heating temperature indicator.

10. Adjusting the passenger's air temperature.

11. Passenger compartment air distribution adjustment.

12. Activation control for the "A/C MAX" function.

13. Air recirculation.

14. Air-conditioning activation control in AUTO mode.

15. De-icing/demisting of the rear screen and, depending on the vehicle, the rear view mirrors.

16. "Clear View" function.

17. Adjusting the ventilation speed and stopping the system.

18. Adjust the driver's air temperature and the activation control for the "Synchronisation" SYNC function (configuration **A**).

AIR VENTS, HEATING AND AIR CONDITIONING

ration **B**).

19. Heated windscreen activation control (configuration **B**).

Activating the system

When the vehicle is started, the system returns to the last programme used.

Press the control **14** to activate the system or set the control **17** to the desired ventilation speed.

Stopping the system

Press the control **17** until it reaches the OFF ».

Switching the air conditioning on or off

In automatic mode, the system manages activation of the air conditioning. You will still be able to activate or deactivate the system by pressing the control **5**.

Automatic mode

The automatic climate control system guarantees comfort in the passenger compartment and good visibility (except in the event of extreme conditions), while optimising fuel consumption.

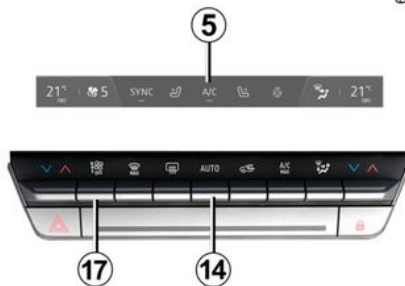

The system controls the ventilation speed, air distribution, air recirculation, and starting and stopping the air conditioning and air temperature.

This mode consists of a choice of three programmes:

AUTO: optimises the selected comfort level according to exterior conditions. Press the button **14**.

SOFT: enables the desired temperature level to be obtained more smoothly and silently. Press button **14** then press downwards again to activate **SOFT** mode.

FAST: increases the air flow in the passenger compartment. This mode is recommended in particular to optimise comfort in the rear seats. Press button

14 then press upwards again to activate **FAST** mode.

When the air conditioning starts in automatic mode, the system returns to the last programme used.



Any action on a button other than the **AUTO** button deactivates automatic mode.

Adjusting the distribution of air in the passenger compartment

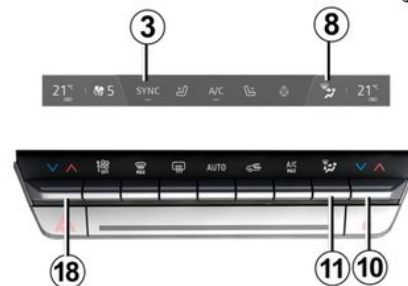

Press **11** one or more times to select the air distribution. The air distribution selected **8** is displayed on the multi-

AIR VENTS, HEATING AND AIR CONDITIONING

media screen. The positions are in the following order:



All the air is then directed to the windscreen and front side window demisting vents.



The air flow is distributed between front side window demisting vents, the windscreen demisting vents and the footwells.



The air flow is distributed between the front side window demisting vents, the windscreen demisting vents, the dashboard air vents and the footwells.



The air flow is mainly directed to the dashboard air vents.



The air flow is directed towards the dashboard vents and towards the footwells.



The air flow is directed mainly towards the footwells.

Adjusting the air temperature

There are two types of settings:

- independent adjustment of the passenger compartment;

- adjusting using the SYNC function to synchronise the passenger side with the driver's side.

Independent adjustment of the passenger compartment

Use controls **10** and **18** to adjust the left-hand and right-hand side independently.

Adjusting using the SYNC

Press SYNC **3** on your multimedia screen or, depending on vehicle, on control **10** or **18** and then SYNC to synchronise the temperature on the passenger side with that on the driver's side.

To exit this function, press again on SYNC or adjust the temperature on the passenger side.

Adjusting the ventilation fan speed

In automatic mode, the system uses the most suitable amount of air to reach and maintain the desired comfort level.

You will still be able to adjust the ventilation speed by pressing the control **17** to increase or reduce the ventilation speed.

"Clear View" function

Press the button **16** and the built-in warning light comes on.

This function quickly de-mists the windscreen, rear screen, front side windows and door mirrors (depending on the vehicle). It automatically activates the air conditioning and rear screen de-icing functions.

To exit this function, press button **14** or **16**.



Some buttons have an operating light indicating their operative state.

Rear screen de-icing and demisting

67128



17 16 15 14 13 12

AIR VENTS, HEATING AND AIR CONDITIONING

Press the button **15** and the built-in warning light comes on. This function enables rapid demisting or de-icing of the rear screen and de-icing of the rear view mirrors (on equipped vehicles).

To exit this function, press button **15** again. Demisting automatically stops.

"A/C MAX" function

The "A/C MAX" function enables the user to feel the maximum power of their air conditioning system without any constraint or compromise related to the acoustics and the feeling of the air being too cold on the hands and face.



This function involves automatic modifications:

- temperature programmed to fully cold;
- distribution of air to the occupants;
- air flow at its maximum power;
- activation of the air conditioning;
- air recirculation.

Press the button **12** to activate the function. Deactivate ECO mode for best performance.

Air recirculation (isolation of the passenger compartment)

This function is managed automatically, but you can also activate it manually. In this case the operation is confirmed by a warning light built into the button **13**.



Demisting/de-icing will still take priority over the air recirculation.

Manual use

Press the button **13** and the built-in warning light comes on.

Prolonged use of this position may lead to odours, caused by non-renewal of air, and the formation of condensation on the windows.

We therefore advise you to return to automatic mode as soon as air recirculation is no longer needed, by pressing button **13**.

"Favourites" function



Depending on the vehicle, by pressing the steering wheel control **20**, you can activate the following functions according to the stored use settings that you have previously defined:

- heated steering wheel;
- heated seats.

For more information on programming this function, please refer to the multimedia instructions.

AIR VENTS, HEATING AND AIR CONDITIONING

ECO mode



From the MULTI-SENSE menu accessible from the multimedia screen **21** or by pressing the switch **22**, you can activate ECO mode, which affects the heating level and reduces the vehicle's fuel consumption.

An ECO warning light located under the temperature display on the multimedia screen **21** informs you that ECO mode is activated.

Air conditioning: programming

Air conditioning programming

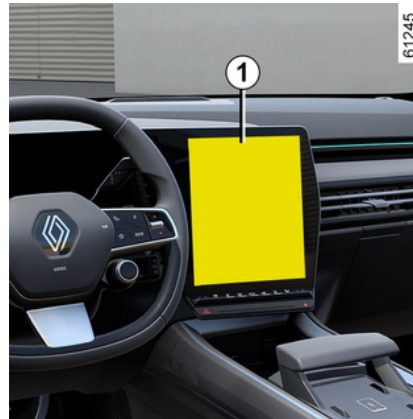

With the vehicle stationary and the engine on, from the "Vehicle" world **2** on the multimedia screen **1**, press the "Electric" menu **3** then the "Charging & Air conditioning" tab to access the settings.

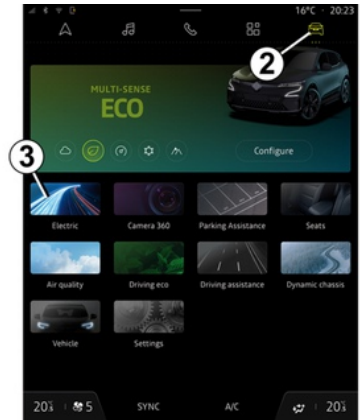

You can save several comfort programmes by activating the following settings:

- temperature adjustment;
- programming the time by which the vehicle must be ready;
- selecting days when the programme must be repeated.

You can activate/deactivate the saved programmes.

Note: you can programme the air conditioning using a smartphone application.

Please refer to the multimedia instructions for further information.

AIR VENTS, HEATING AND AIR CONDITIONING



Driver's responsibility when parking or stopping the vehicle

Never leave an animal, child or adult who is not self-sufficient alone in your vehicle, even for a short time.

In hot and/or sunny weather, please remember that the temperature inside the passenger compartment increases very quickly.

RISK OF DEATH OR SERIOUS INJURY.

Activating "Programming"

The function launches before the time programmed by the customer, so that the vehicle reaches a comfortable temperature by the time they arrive, if:

- the bonnet is closed;
- the traction battery charge level is over 7.5%;
- the engine is stopped;
- the driver is not in the vehicle.

Warning light  comes on the instrument panel.

Immediate activation of the air-conditioning

It is possible to carry out immediate starting of the air conditioning, if:

- the bonnet is closed;
- the traction battery charge level is over 7.5%;
- the engine is stopped;
- the driver is not in the vehicle.

The operation of the immediate activation of the air-conditioning is different from programming:

- it must be launched from your smartphone;
- the heated steering wheel and seats function, if your vehicle is equipped, is activated automatically;
- the function stops after approximately 10 minutes.

Please refer to the multimedia instructions for further information.

Stopping the programmed air conditioning

The air conditioning stops automatically around ten minutes after the set end time.

However, the function can be deactivated if:

- the engine is running;
- the traction battery charging level is lower than 7%;

- the bonnet is open;
- you press one of the switches on the control panel;
- the driver is in the passenger compartment for approximately 20 seconds.

Note: these conditions are also applicable for the immediate deactivation of the air conditioning.

If the vehicle is parked for a long time without opening a door with at least one active pre-conditioning schedule, then the function will be deactivated from the third pre-conditioning launch included. The function will be available when one of the doors of the vehicle is opened.

Air conditioning: information and advice on use

Advice on use

In some situations (air conditioning off, air recirculation activated, ventilation speed at zero or low etc.), you may notice that condensation starts to form on the windows and windscreen.

If there is condensation, use the "**Clear View**" function to remove it, then use the air conditioning in automatic mode to stop it forming again.

AIR VENTS, HEATING AND AIR CONDITIONING



Do not add anything to the vehicle's ventilation circuit (for example, to remove bad odours).

There is a risk of damage or of fire.

Fuel consumption

You will normally notice an increase in fuel consumption (especially when driving in town) when the air conditioning is operating.

For vehicles fitted with air conditioning with no automatic mode, switch off the system when it is not required.

Advice for reducing consumption and helping to preserve the environment

Drive with the air vents open and the windows closed. If the vehicle has been parked in the sun, open the doors for a few moments to let the hot air escape before starting the engine.

Maintenance

Refer to the maintenance document for your vehicle for the inspection frequency.



Use the air conditioning system regularly, even in cold weather, running it at least once a month for approximately 5 minutes.

Operating faults

As a general rule, contact your approved dealer in the event of an operating fault.

– Reduction in de-icing, demisting or air conditioning performance.

This may be caused by the cabin filter cartridge becoming clogged.

– No cold air is being produced.

Check that the controls are set correctly and that the fuses are sound. Otherwise, switch off the system.

Special cases of hybrid versions

The vehicle's air conditioning system is used to cool the traction battery.

A prolonged drop in air conditioning efficiency may lead to premature deterioration of the traction battery.

Presence of water under the vehicle

After prolonged use of the air conditioning system, it is normal for water to

be present under the vehicle. This is caused by condensation.



Do not open the refrigerant circuit. The fluid may damage eyes or skin.

Refrigerant fluid



The refrigerant fluid circuit (of which some components are hermetically sealed) may contain fluorinated greenhouse gases.

Depending on the vehicle, you will find the following information on label **A** affixed inside the engine compartment.

59952

AIR VENTS, HEATING AND AIR CONDITIONING

The presence and location of the information on label **A** depends on the vehicle.

- (1) 0.689 kg
- (2) GPWP 4
- (3) 0.003t



Type of refrigerant fluid



Type of oil in the air conditioning circuit



Inflammable product



Consult the vehicle user manual



Maintenance

x.xxx kg	(1) Quantity of refrigerant fluid present in the vehicle.
GWP xxxxx	(2) Global Warming Potential (CO2 equivalent).
CO2 eq x, xxxt	(3) Quantity in weight and in CO2 equivalent.



Do not open the refrigerant circuit. The fluid may damage eyes or skin.



Before carrying out any action in the engine compartment, you must switch off the ignition

→ 160.

Additional information

Depending on label and depending on the type of refrigerant:

Refrigerant fluid R-1234yf

MULTIMEDIA EQUIPMENT

Multimedia screen



The location and operation of equipment may vary according to the vehicle.

1. Multimedia screen.
2. Two multimedia sockets USB-C on the centre console.
3. Steering column control.
4. Phone control.
5. Two multimedia sockets USB-C.
6. Two multimedia sockets USB-C in the central armrest of the rear bench seat.



Please refer to the multimedia instructions for further information.

"USB-C" multimedia ports

The USB-C multimedia ports **2**, **5** and **6** can be used to charge accessories with a maximum power of 15 Watts (5 Volts) per port.

Note: the USB-C **2** multimedia ports also allow for data transfer.



Connect accessories with a maximum power of 15 Watts only.
Fire hazard.

MULTIMEDIA EQUIPMENT

Microphone



Microphone **7** (for the telephone and voice assistant)



Using the telephone

We remind you of the need to conform to the legislation in force concerning the use of such equipment.

Wireless charger



Wireless charger **8** → **322**

PASSENGER COMPARTMENT EQUIPMENT

Electric windows

These systems operate with the ignition on or off, until one of the front doors is opened (limited to about 3 minutes).



Driver's responsibility

Never leave your vehicle with the card or key inside, with a child, adult who is not self-sufficient or a pet in the vehicle, even for a short while.

They may pose a risk to themselves or to others by starting the engine or activating equipment (such as the gear lever or electric windows).

If any part of the body becomes trapped, reverse the direction of the window immediately by pressing the relevant switch.

Risk of serious injury.

One-touch electric windows



Briefly press or pull a window switch as far as it will go: the window will be fully raised or lowered. Pressing the switch again stops the window moving.

Note : the rear windows do not open fully.

From the driver's seat, use switch:

1. for the driver's side;
2. for the front passenger's side;
3. and 5 for the rear passengers;
4. to lock the rear windows.

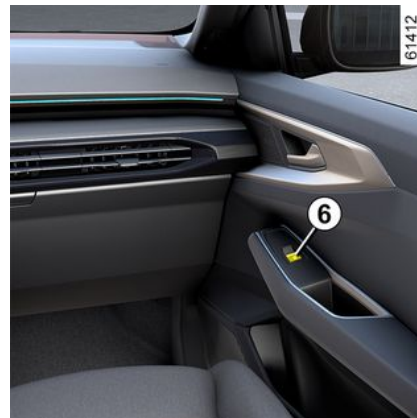

Note: after the rear windows are locked, the "Rear windows locked" message appears on the instrument panel.

From the passenger seat, press switch 6.



Avoid resting any objects against a half-open window: there is a risk that the electric window could be damaged.

Note: if the window detects resistance when almost fully closed (e.g. a tree

PASSENGER COMPARTMENT EQUIPMENT

branch), it stops and then lowers again by a few centimetres.

Impossible to operate the one-touch electric window

The one-touch electric window is equipped with heat protection: if you press the switch for the window more than 16 consecutive times it goes into protection mode (locking the window).

You can:

- use the electric window switch briefly and with intervals of approximately 30 seconds;
- with the engine running, the window will be unlocked after approximately 20 minutes of inaction on the electric window switch.

Remote control window opening/closing

When unlocking the doors from the outside, if you **press and hold the card unlocking button**, all the windows equipped with a one-touch electric window will open automatically.

When locking the doors from the outside, if you **press and hold the card locking button**, all the windows equipped with a one-touch electric window will close automatically.

It is recommended that the user only operates the system when the vehicle

can be seen clearly and no one is inside.



Passenger safety

The driver can prevent the front and rear passenger electric windows from operating (and the driver's window) by pressing switch **4**. A confirmation message is displayed on the instrument panel.

Operating faults

In case of a fault when closing a window, the system reverts to normal mode: pull the switch concerned up as often as necessary to fully close the window (the window will close gradually), hold the switch (still on the closure side) for one second then lower and raise the window fully to reinitialise the system.

If necessary, contact an approved Dealer.



When closing the windows, ensure that no part of the body (arm, hand, etc.) is protruding from the vehicle.

Risk of serious injury.

Opaque panoramic roof

The panoramic roof made of opaque glass is divided into two sections (front and rear).

It can become totally opaque or completely transparent. You can also make only one area opaque (front or rear).

Each transition or transition request is accompanied by an animation representing the roof.

PASSENGER COMPARTMENT EQUIPMENT

Operation



To make **the entire roof** opaque or transparent, press and hold switch **1**.

To change **one of the sections (front or rear)** to opaque or transparent mode, press briefly on switch **1** as many as times as required.

Note: before pressing switch **1** again, you must wait for the previously selected action to be completed.

Depending on the vehicle, it is also possible to operate the vehicle by voice command. Please refer to the multimedia instructions for more information.

i The roof becomes completely opaque after the doors are locked or the vehicle goes on standby (with the doors unlocked and the engine off, the instrument panel and/or multimedia screen switch off).

i When the instrument panel and multimedia screen are switched on (welcome sequence) or when the engine start/stop button is pressed, the roof adopts the setting stored before the vehicle was last put on standby or when the doors were locked.

Limits of operation

In very cold weather conditions, the panoramic roof may have limited operation (reduced movement) or may not work at all.

Interior lighting

Map reading lights

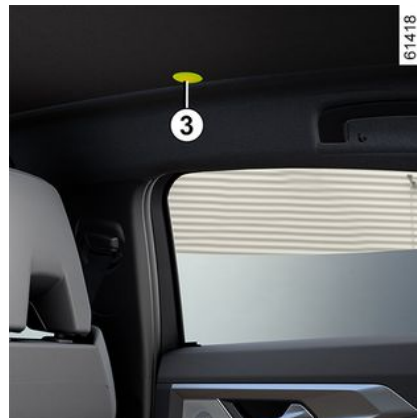
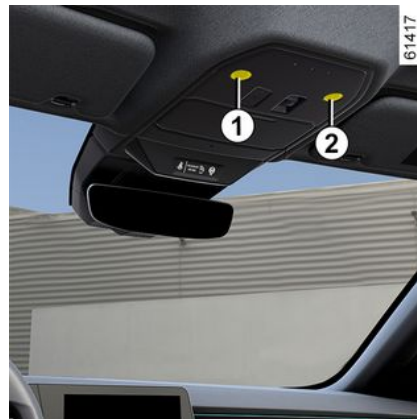

PASSENGER COMPARTMENT EQUIPMENT



Touch the reading light **1, 2, 3** to activate:

- permanent lighting;
- lighting switches off immediately.

Note:

- It is not necessary to press the lights to activate or deactivate the lighting. You only need to make contact;
- you can deactivate/activate the illumination of the reading lights when the doors are opened using the multimedia screen → **130**.

 Unlocking and opening the doors or tailgate switches on the timed courtesy lights and lights.

Luggage compartment light



The light **4** comes on when the luggage compartment is opened.

 Unlocking and opening the doors or tailgate switches on the timed courtesy lights and lights.

Sun visor

Front sun visor



Lower the sun visor **2**.

Courtesy mirrors

(depending on the vehicle)

Lift the cover **1**. The lighting **3** is automatic.



When driving, ensure the courtesy mirror cover is closed.

Risk of injury.

PASSENGER COMPARTMENT EQUIPMENT



Accessories socket

Accessories sockets 1



You can use the accessory sockets 1 to connect accessory devices.



Connect accessories with a maximum power of 120 watts (12 V) only.

When several accessory sockets are used at the same time, the total power of the connected accessories must not exceed 180 watts.

Fire hazard.

PASSENGER COMPARTMENT STORAGE, FITTINGS

Front door storage compartment 1



They can hold a 1.5-litre bottle.



Nothing should be placed on the floor (area in front of the driver) as these objects may slide under the pedals during sudden braking manoeuvres, thus obstructing their use.

Sun blind storage compartment 2



This can be used for storing motorway tickets, cards, etc.



Ensure that no hard, heavy or pointed objects are placed in the "open" storage compartments in such a way that they may be projected onto passengers during sudden turning, braking or in the event of deployment of the airbags.

Centre console storage compartment/induction charging zone 3

For more information on the induction charging zone, please refer to the multimedia instructions.



Depending on the country and the subscription, the induction charging zone **3** is also the placement area for smartphones equipped with a digital key ➔ 58.

PASSENGER COMPARTMENT STORAGE, FITTINGS

i You must not leave any object (starting card, USBflash drive or SDcard, credit card, jewellery, key, coins, etc.) in the induction charging zone **3** when charging your phone. Remove any magnetic cards or credit cards from the phone case before positioning your telephone in the induction charging area **3**.

i Objects left in the induction charging area **3** may overheat. You are advised to place them in the areas provided for this purpose (storage compartment, sun visor compartment etc.).

Passenger storage drawer 4

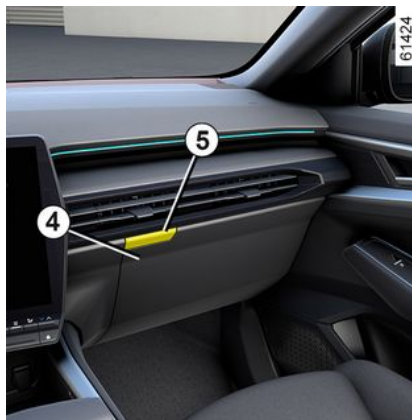

To open, press button **5**.

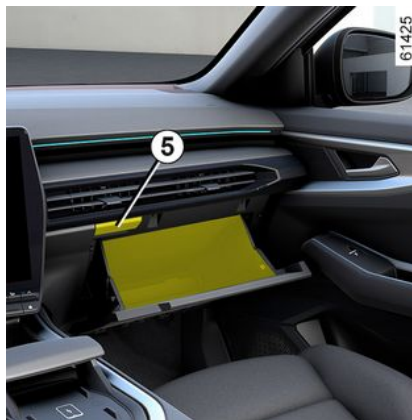

Centre armrest storage compartment 6



Open the cover **7** of the central armrest by pressing the button **8**.



Do not place any object(s) on the central armrest compartment as this could hinder the operation of the sideairbag and/or lead to injury during inflation.

PASSENGER COMPARTMENT STORAGE, FITTINGS



Cup holders 9



Depending on the vehicle, the cup holder may be equipped with retaining hooks to keep the cup in place.

This can be used to store a mobile ashtray, drink cans, etc.

Rear doors storage compartments 10



They may receive a 0.11 gal (0.5 litre) bottle or a 0.22 gal (1 litre) bottle, depending on the vehicle.



Do not drive with the central armrest in the open position as this could hinder the operation of the airbag and/or lead to injury during inflation.



When turning corners, accelerating or braking, ensure that the receptacle being held by the cup holder is not dislodged.

There is a risk of injury if hot liquid escapes.

PASSENGER COMPARTMENT STORAGE, FITTINGS

Rear seats storage nets 11



(depending on the vehicle)



Ensure that no hard, heavy or pointed objects are placed in the "open" storage compartments in such a way that they may be projected onto passengers during sudden turning, braking or in the event of an accident.

Grab handle 12



This offers support and can be held when the vehicle is moving. You can use it to get into or out of the vehicle.

Central rear armrest 13

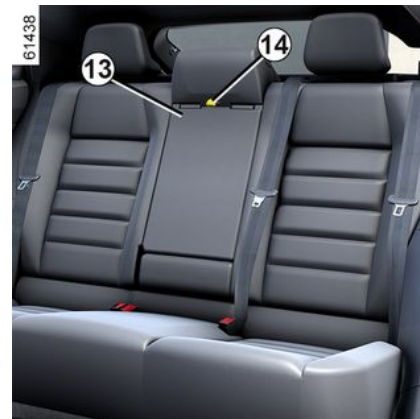

PASSENGER COMPARTMENT STORAGE, FITTINGS

To access the central armrest **13**, pull the strap **14**.

 Be sure to store the cup holders **15** before closing the armrest.

 When closing the armrest, make sure that no body parts (arms, hands, fingers, etc.) are near the locking area.
Risk of trapping.

Cup holders **15**

 When turning corners, accelerating or braking, ensure that the receptacle being held by the cup holder is not dislodged.
There is a risk of burning if hot liquid escapes.

Storage compartment **16** in the rear central armrest



Lift the cover **17**

 When driving, make sure that the cover **17** is properly closed.
In the event of sudden braking there is a risk of the cover closing by accident.

Tablet holder **18**

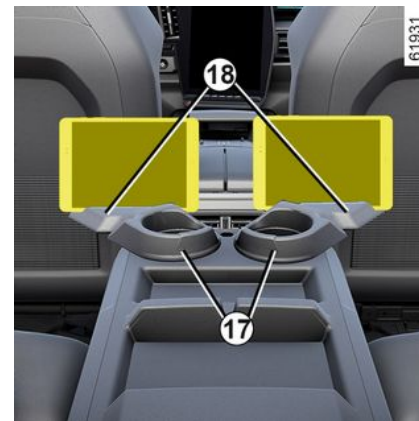

Rotate the cup holders **17**, then insert the tablet in the housing to hold it in place.

 The housings must only be used to store tablets or smartphones.

PASSENGER COMPARTMENT STORAGE, FITTINGS

Ski rack 19



If you want to carry long objects (skis, etc.) in the luggage compartment, pull

the strap **20** located behind the central headrest to lower the central seat.

 Before lowering the central seatback, make sure that the central armrest is properly locked in its housing.

 With the central seat lowered, before lowering a side seat ensure that no body parts (arms, hands, fingers, etc.) are protruding and/or near the locking system **21**.
Risk of trapping.

TRANSPORTING OBJECTS

Luggage compartment storage

Rear parcel shelf, removal



- Unhook the two cords **1** from the luggage compartment;
- lift the shelf **2** to unclip it (movement **A**);
- pull the shelf towards you.

To refit, proceed in the reverse order to removal.



Do not place any heavy or hard object on the parcel shelf. These may pose a risk to the vehicle occupants if the driver has to brake suddenly or if the vehicle is involved in an accident.

Transporting objects in the luggage compartment

Always position the objects transported so that the largest surface is against:



- The back of the rear bench seat, for normal loading (example **A**).
- the front seatbacks with the rear seatbacks folded down, as is the case for maximum loads (example **B**).

Ensure that the objects being transported are evenly distributed throughout the loading area.

If you have to place objects on the folded seat back, it is vital that you remove the headrests before folding the seat back so that it can be folded as flat as possible against the seat.

TRANSPORTING OBJECTS

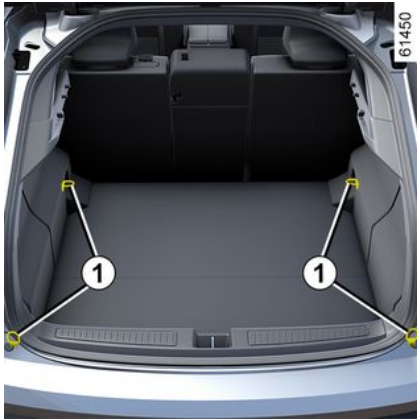

Always position the heaviest items directly on the floor. If the vehicle is equipped, use the lashing points **1** located on the luggage compartment floor. The luggage should be loaded in such a way that no items will be thrown forward and strike the occupants if the driver has to brake suddenly. Fasten the rear seat belts, even if the seats are not occupied.

Towbar



Permissible nose weight, maximum permissible towing weight while braked and unbraked: → 382. Choice and fitting of towing equipment

Towbar (cross member and hitch) not originally fitted to the vehicle: the entire towbar and mountings must not exceed 32 kg.

Any towing device must not obstruct any lighting component or the number plate when not in use. In all cases, you must comply with the regulations of the particular country you are in.

For fitting and conditions of use, refer to the equipment's fitting instructions.

Please keep these instructions with the rest of the vehicle documentation.

63561

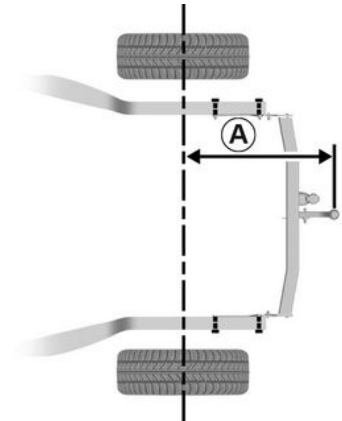

Maximum dimension **A**: 1,042 mm.

63562

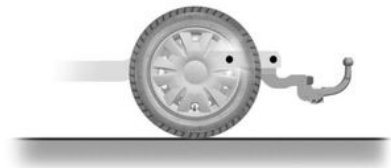

TRANSPORTING OBJECTS

Roof bars, spoiler

Accessing the mounting points

Vehicles not fitted with longitudinal roof bars



Open the doors to access the mounting points **1**.

 For information on the range of equipment adapted to your vehicle, we advise you to consult an approved dealer. Refer to the fitting instructions for information on how to fit roof bars and conditions of use. Please keep these instructions with the rest of the vehicle documentation.

Maximum permissible load on roof → 382.

 If original roof bars, approved by our Technical Department, are supplied with screws, only use these screws for attaching the roof bars to the vehicle.

User precautions

Handling the tailgate

Before operating the luggage compartment door, check the objects and/or accessories (bicycle rack, roof box, etc.) fitted on the roof bars: these must be correctly positioned and secured,

and must not prevent the luggage compartment door from operating correctly.

Spoiler A



It is prohibited to attach any carrying equipment (bike rack, luggage box etc.) resting against the spoiler or tailgate. To install a carrying device on your vehicle, contact an approved dealer.

ACCESSING THE ENGINE, LEVELS

Bonnet

To open, pull the handle **1** located on the left-hand side of the dashboard.



Before carrying out any operation in the engine compartment, you must switch off the ignition.



Avoid placing any pressure on the engine bonnet: risk of the bonnet closing by accident.

Unlocking the bonnet catch



To unlock, push the lever **2** to the left while raising the bonnet.



Please note when working close to the engine that it may be hot. The engine cooling fan may also start at any moment. The



label in the engine compartment reminds you of this.
Risk of injury.

Opening the bonnet

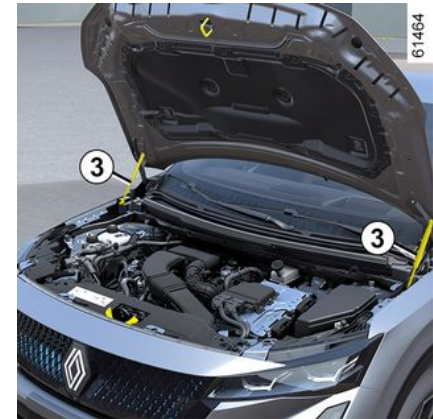

Raise the bonnet and guide it – the bonnet is held up by two struts **3**.



When working in the engine compartment, ensure that the windscreen wiper stalk is in the park position.
Risk of injury.

Closing the bonnet

Before closing the bonnet, make sure that nothing has been left in the engine compartment.

ACCESSING THE ENGINE, LEVELS

To close the bonnet again, hold it in the middle and release it around 30 cm above the closed position.

If necessary, press down along the bonnet to lock completely.



Never handle the struts when closing the engine bonnet.



Ensure that the bonnet is properly locked. Check that nothing is preventing the catch from locking (gravel, cloth, etc.).



After any procedure in the engine compartment, make sure that you do not forget anything (cloth, tools, etc.). Otherwise, this may lead to engine damage or cause a fire.



In the event of even a slight impact involving the radiator grille or bonnet, have the bonnet lock checked by an approved Dealer as soon as possible.

Engine oil

General information

It is normal for an engine to use oil for lubrication and cooling of moving parts and it is normal to top up the level between oil changes.

However, contact your approved Dealer if more than 0.11 gal (0.5 litre) is being consumed every 600 miles (1,000 km) after the running in period.

Oil change frequency: check the oil level from time to time and certainly before any long journey to avoid the risk of damaging your engine.



Exceeding the maximum engine oil level

Under no circumstances should the maximum filling level **B** be exceeded: this could damage the engine and the emission control system. If the oil level exceeds the maximum level, **do not start your vehicle** and contact an approved dealer.

Reading the oil level

The oil level should be read with the vehicle on level ground, after the engine has been switched off for some time.

The dipstick must be used to read the exact oil level and make sure that the maximum level has not been exceeded (risk of engine damage).

Depending on the vehicle, the instrument panel display only alerts the driver when the oil level is at its minimum.

ACCESSING THE ENGINE, LEVELS



Adding engine oil

Use a funnel or protect the filling neck area to avoid engine oil escaping on to a hot part of the engine compartment or a sensitive part (e.g. electrical components).

Fire hazard.



Filling and/or checking the oil level:

when topping up or checking the oil level, ensure that no oil leaks onto the engine components. Do not forget to properly close the cap and refit the dipstick to prevent any oil spatter on hot engine components.

Fire hazard.



Before carrying out any action in the engine compartment, you must switch off the ignition

→ 160.

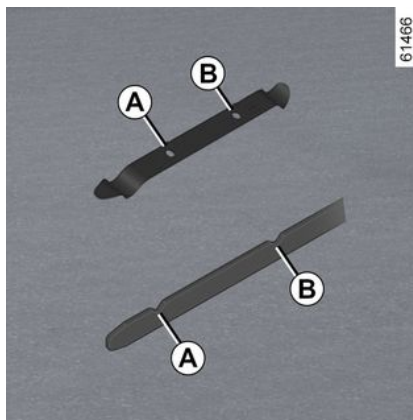

- Remove the dipstick and wipe with a clean, lint-free cloth;
- push the dipstick in as far as it will go;
- remove the dipstick again;
- read the level: it should never fall below the "MINI" level **A** nor rise above the "MAXI" level **B**.

Once the level has been read, push the dipstick in as far as it will go.

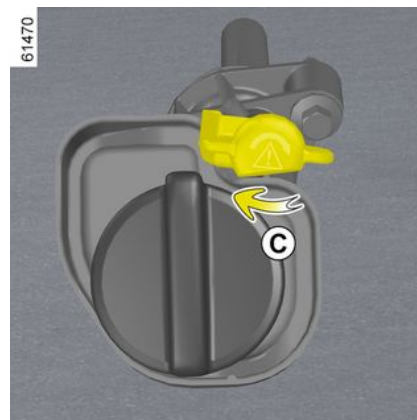

Depending on the vehicle, it may be necessary to lock the oil dipstick: push the dipstick as far as it will go, then rotate it to lock it (movement **C**).

ACCESSING THE ENGINE, LEVELS

Topping up, filling, draining

Topping up/filling



The vehicle must be parked on level ground and the engine should be stopped and cold (for instance, before the engine is started up for the first time in the day).

- Loosen the cap **1**;
- top up the level (as a guide, the capacity between the "MINI" and "MAXI" level of the dipstick **2** is between 0.20 gal (0.9 l) and 0.44 gal (2 l), depending on the engine);



Do not exceed the "MAXI" level and remember to refit the cap **1** and the dipstick

2.

- wait for approximately 20 minutes to allow the oil to flow;
- check the level using the dipstick **2** (as described previously).

Once the level has been read, remember to insert the dipstick as far as it will go and, depending on the vehicle, turn it a quarter of a turn to lock it. Fully tighten the cap-dipstick → **332**.



Before carrying out any action in the engine compartment, you must switch off the ignition

→ **160**.



Adding engine oil

Use a funnel or protect the filling neck area to avoid engine oil escaping on to a hot part of the engine compartment or a sensitive part (e.g. electrical components).

Fire hazard.

Oil change

Service interval: refer to the maintenance document for your vehicle.

Oil change capacity

Please refer to the maintenance document for your vehicle, or contact an authorised dealer. Always check the engine oil level using the dipstick, as explained previously (it should never fall below the "MINI" level nor exceed the "MAXI" level on the dipstick).

Engine oil grade

Refer to the maintenance document for your vehicle.

ACCESSING THE ENGINE, LEVELS



Filling and/or checking the oil level: when topping up or checking the oil level, ensure that no

oil leaks onto the engine components. Do not forget to properly close the cap and refit the dipstick to prevent any oil spatter on hot engine components.

Fire hazard.



Please note when working close to the engine that it may be hot. The engine cooling fan may also start at any moment. The

warning light  in the engine compartment reminds you of this. **Risk of injury.**



If there is an abnormal or repeated drop in the fluid level, consult an approved dealer.



When working in the engine compartment, ensure that the windscreen wiper stalk is in the park position.

Risk of injury.



Engine oil change: if you are changing the oil when the engine is hot, be careful not to scald yourself as the oil drains.



Exceeding the maximum engine oil level
Under no circumstances should the maximum filling level be exceeded: this could damage the engine and the emission control system.
If the oil level exceeds the maximum level, **do not start your vehicle** and contact an approved dealer.



Never run the engine in an enclosed space as exhaust gases are poisonous.

Coolant level

Combustion engine coolant 1

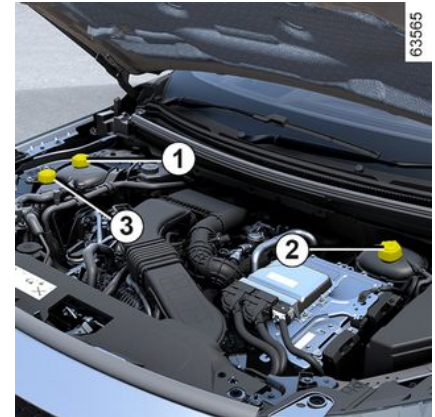

Electric traction system coolant 2

This system is different to that of the combustion engine. It is used for cooling the electric motor.

ACCESSING THE ENGINE, LEVELS

Combustion engine air turbocharging coolant 3 (depending on the vehicle)

Check the level of the coolants 1, 2 and 3

With the engine switched off and the vehicle parked on flat ground, the level when cold must be between the "MINI" and "MAXI" marks indicated on the coolant reservoir 1. Top up the level when cold before it reaches the "MINI" mark.



If there is an abnormal or repeated drop in the fluid level, consult an approved dealer.



Before carrying out any action in the engine compartment, you must switch off the ignition

→ 160.



When working in the engine compartment, ensure that the windscreen wiper stalk is in the park

position.

Risk of injury.



Please note when working close to the engine that it may be hot. The engine cooling fan may also start at any moment. The



label in the engine compartment reminds you of this.

Risk of injury.



No operations should be carried out on the cooling circuit when the engine is hot.

Risk of burns.

caused to the engine if it runs out of coolant).

If the level needs to be topped up, only use products approved by our Technical Department which ensure:

- antifreeze protection;
- anti-corrosion protection of the cooling system.

Replacement intervals

Refer to the maintenance document for your vehicle.



If there is an abnormal or repeated drop in the fluid level, consult an approved dealer.



Before carrying out any action in the engine compartment, you must switch off the ignition

→ 160.

Frequency of checking coolant level

Check the coolant level regularly (very severe damage is likely to be

ACCESSING THE ENGINE, LEVELS



When working in the engine compartment, ensure that the windscreen wiper stalk is in the park position.

Risk of injury.



Please note when working close to the engine that it may be hot. The engine cooling fan may also start at any moment. The



label in the engine compartment reminds you of this.

Risk of injury.



No operations should be carried out on the cooling circuit when the engine is hot.

Risk of burns.

Levels, filters

Brake fluid level



This should be checked frequently, and immediately if you notice even the slightest loss in braking efficiency.

The level should be read with the engine switched off and on level ground.

Level 4

It is normal for the level to fall as the trims become worn, but it must never fall below the "MINI" warning line.

If you wish to check the disc and drum wear yourself, you should obtain the document explaining the checking procedure from the manufacturer's network or website.

Topping up

After any operation on the hydraulic circuit, a specialist must replace the fluid.

Only use fluids approved by our Technical Department (and taken from a sealed container).

Replacement intervals

Refer to the maintenance document for your vehicle.



If there is an abnormal or repeated drop in the fluid level, consult an approved dealer.



Please note when working close to the engine that it may be hot. The engine cooling fan may also start at any moment. The



label in the engine compartment reminds you of this.

Risk of injury.

ACCESSING THE ENGINE, LEVELS

Windscreen washer reservoir



Topping up

With the engine off, open the cap **5**. Fill until you can see the fluid, then replace the cap.

Note: check the reservoir level regularly and top up the fluid before going on a trip.

Fluid

Windscreen washer fluid. In winter, use anti-freeze product. Use products recommended by an authorised dealer.

Note: do not use hard water (risk of damage to the priming pump, limescale building up on the pump and the jets).

Jets

To adjust the height of the windscreen washer jets, please consult an authorised dealer.



Before carrying out any action in the engine compartment, you must switch off the ignition

→ 160.

Filters

The replacement of filter elements (air filter, cabin filter, diesel filter etc.) is scheduled in the maintenance operations for your vehicle.

Replacement intervals for filter components: refer to the maintenance document for your vehicle.



When working in the engine compartment, ensure that the windscreen wiper stalk is in the park

position.

Risk of injury.



Please note when working close to the engine that it may be hot. The engine cooling fan may also start at any moment. The

warning light  in the engine compartment reminds you of this. **Risk of injury.**

BATTERY

12 volt battery

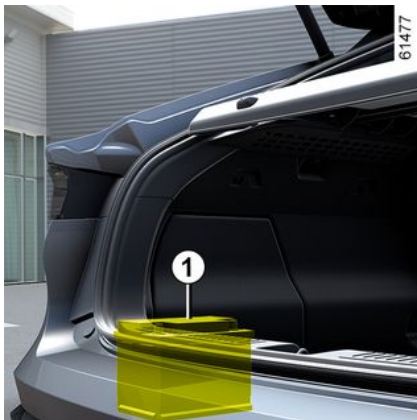

The battery **1** is located in the vehicle luggage compartment.

The battery **1** does not require maintenance. **You should not open it or add any fluid.**

Depending on the vehicle, a system continuously checks the battery charge status. If it decreases, the "Battery energy saving mode" message then the "Low battery - Start engine" message is displayed on the instrument panel. In this case, start the engine and the message on the instrument panel will disappear.

Note: the "Battery energy saving mode" message may be displayed af-

ter 5 to 30 minutes of vehicle use with the engine stopped to warn the user that the power consuming functions (interior lighting, radio, navigation, ventilation, accessories power supply, etc.) may be cut off automatically.

Your battery charging status may diminish, especially if you are using your vehicle:

- for short trips;
- in an urban setting;
- when the temperature is low;
- after extended use of energy-consuming devices (radio, etc.) with the ignition switched off.

Label A



Observe the indications on the battery:

- **2** naked flames and smoking are prohibited;
- **3** eye protection compulsory;
- **4** keep away from children;
- **5** explosive material;
- **6** refer to the manual;
- **7** corrosive materials.



For your own safety and for the proper operation of the vehicle's electrical equipment (lights, wind-screen wipers, ABS, etc.), any intervention on the battery (removal, disconnection, etc.) must categorically be performed by a specialist professional.

Risk of serious burns or electric shocks.

You must respect the replacement intervals (without exceeding them) as stated in the maintenance document.

The battery is a specific type. Please ensure it is replaced with the same type.

Call an approved dealer.

CLEANING

Bodywork maintenance

A well-maintained vehicle will last longer. It is therefore recommended to maintain the exterior of the vehicle regularly.

Your vehicle has been treated with very effective anti-corrosion products. It is nevertheless subject to various outside influences.

Corrosive agents in the atmosphere

- atmospheric pollution (in built-up and industrial areas);
- saline atmospheres (near the sea, particularly in hot weather);
- seasonal and damp climatic conditions, (e.g.: road salt in winter, water from road cleaners, etc.).

Minor impacts

Abrasive action

Dust and sand in the air, mud, road grit thrown up by other vehicles, etc.

You should take a number of minor precautions in order to safeguard your vehicle against such risks.

You should do the following

Wash your car frequently, **with the engine off**, with cleaning products recommended by our Technical Department (never use abrasive products).

Rinse thoroughly beforehand using a jet washer:

- spots of tree resin and industrial pollution;
- mud in the wheel arches and underneath the body which forms damp patches;
- **bird droppings, which cause a chemical reaction with the paint that rapidly discolours paintwork and may even cause the paint to peel off.**

Wash the vehicle **immediately** to remove these marks as it is impossible to remove them by polishing;

- salt, particularly in the wheel arches and underneath the body after driving in areas where the roads have been gritted.

Withdraw the vegetable falls (resin, film etc.) from the vehicle regularly.

Observe the vehicle stopping distances when driving on gravelled surfaces to prevent paint damage.

Repair, or have repaired quickly, areas where the paint has been damaged, to prevent corrosion spreading.

Remember to visit the body shop periodically in order to maintain your anti-corrosion warranty. Refer to the maintenance document.

Observe local regulations about washing vehicles (e.g. do not wash your vehicle on a public highway).

When washing the vehicle with a high-pressure cleaning device, please take the following precautions:

- make sure that your vehicle's paintwork, the area or the component that you want to clean is compatible with this type of washing;
- the pressure delivered by the device must be less than 100 bar;
- when washing, position the spray nozzle at least 15 cm from the vehicle and check that the water flow rate is less than 3.30 gal (15 l)/min);
- do not persist in washing the same area, impacted points or the seals (risk of damage to the paint, seals becoming detached, etc.).

If mechanical components, hinges, etc. have been cleaned, they must be protected again by spraying with products approved by our Technical Department.



We have selected special products to care for your vehicle and you can obtain these from the manufacturer's accessory outlets.

CLEANING

Do not do the following

Wash the vehicle in bright sunlight or freezing temperatures.

Do not scrape off mud or dirt without pre-wetting.

Allow dirt to accumulate on the exterior.

Allow rust to form following minor impacts.

Using solvents not approved by our Technical Department to remove stains may damage the paintwork.

Do not drive in snow or muddy conditions without washing the vehicle, particularly under the wheel arches and body.



Degrease or clean using high-pressure cleaning equipment or by spraying products not approved by our Technical Department:

- mechanical components (e.g. engine compartment);
- wheels (e.g. braking system components such as brake callipers);
- the underbody;
- the parts with hinges (e.g. inside the doors);
- the painted plastic external fittings (e.g. bumpers).

Doing this could give rise to corrosion or operational faults.

Using a roller type car wash

Return the wiper stalk to the Park position → 152. Check the mounting of external accessories, additional lights and rear view mirrors, and ensure that the wiper blades are secured with adhesive tape.

Remove the radio aerial mast if your vehicle is fitted with this equipment. Check that the fuel filler flap is closed then lock the vehicle.

Remember to remove the tape and re-fit the antenna after washing.

Cleaning the headlights, sensors and cameras

Use a soft cloth or cotton wool. If this does not clean them properly, moisten the cloth with soapy water, then wipe clean with a soft damp cloth or cotton wool.

Finally, carefully dry off with a soft dry cloth.

The use of cleaning products containing alcohol or utensils (e.g. a scraper) is prohibited.

Cleaning stickers, decorative films, etc.

You should do the following

Use a soft cloth or cotton wool.

Moisten it slightly with soapy water then always wipe clean with a soft cloth or cotton wool.

Finally, carefully dry off with a soft dry cloth.

Do not do the following

Use alcohol-based cleaning products.

Use utensils (e.g. a scraper).

Rub too hard.



Wash the vehicle using a high-pressure cleaning device.

Interior trim maintenance

A well-maintained vehicle will last longer. It is therefore recommended to maintain the interior of the vehicle regularly.

A stain should always be dealt with swiftly.

Whatever the type of stain, use **cold (or tepid) soapy water prepared with natural soap.**

CLEANING

Detergents (washing-up liquid, powdered products, alcohol-based products) should not be used.

Use a soft cloth.

Rinse and wipe up excess water.

Multimedia screen

Maintenance of the screen may depend on the type of multimedia equipment. Please refer to the multimedia instructions for further information.

Glass instrument panel

(e.g. instrument panel, clock, exterior temperature display)

Use a soft cloth or cotton wool.

If this does not clean them properly, use a soft cloth (or cotton wool) slightly moistened with soapy water and then wipe clean with another soft damp cloth or cotton wool.

Finally, **carefully** dry off with a soft dry cloth.

Do not use products containing alcohol and/or spray fluids on the area.

Seat belts

These must be kept clean.

Use products selected by our Technical Department (approved outlets) or

warm, soapy water and a sponge and wipe with a dry cloth.

Detergents or dyes must not be used under any circumstances.

Textiles (seats, door trim, etc)

Vacuum-clean the textiles **regularly**.

Liquid stain

Use soapy water.

Dab lightly (never rub) with a soft cloth, rinse and remove the excess.

Solid or pasty stain

Carefully remove the excess solid or pasty material **immediately** using a spatula (working from the edges to the centre to avoid spreading the stain).

In the case of a liquid stain, clean as indicated.

Special instructions for sweets or chewing gum

Fit an ice cube on the stain to solidify it, then proceed as for a solid stain.



For further recommendations for maintaining the interior, and/or for any unsatisfactory results, please see an authorised dealer.

Removal/replacing removable equipment originally fitted in the vehicle

If you need to remove equipment in order to clean the passenger compartment (for example, mats), always ensure that they are correctly refitted and are the right way around (the driver's mat should be fitted on the driver's side, etc.) and fit them with the components supplied with the equipment (for example, the driver mat should always be fixed using the pre-fitted mounting components).

With the vehicle stationary, always ensure that nothing will impede driving (anything obstructing the pedals, heel wedged by the mat etc.).

Do not do the following

Position objects such as deodorants, scents etc. near air vents as this could damage your dashboard trim.



Use high-pressure cleaning equipment or sprays inside the passenger compartment:

without careful use, this equipment could impair the correct functioning of the electrical or electronic components

CLEANING

in the vehicle, or have other detrimental effects.

TYRES

Tyres

Tyre and wheel safety

The tyres are the only contact between the vehicle and the road, so it is essential to keep them in good condition.

You must make sure that your tyres conform to local road traffic regulations.

Maintaining the tyres

The tyres must be in good condition and the treads must have sufficient depth: tyres approved by our Technical Department have wear warning strips **1** which are **indicators moulded into the tread at several points**.



Incidents which occur when driving, such as striking the kerb, may damage the tyres and wheel rims, and could also lead to misalignment of the front or rear axle geometry. In this case, have the condition of these checked by an approved dealer.



When the tyre tread has been worn to the level of the wear indicators **these become visible 2** : it will then be **necessary to replace your tyres as the tread depth will be 1.6 mm at most, resulting in poor road-holding on wet roads.**

An overloaded vehicle, long journeys by motorway, particularly in very hot weather, or continual driving on poorly surfaced minor roads will lead to more rapid tyre wear and affect safety.

Tyre pressures

Adhere to the tyre pressures (including the emergency spare wheel). The tyre pressures should be checked at least once a month and additionally before

any long journey (refer to the label affixed to the edge of the driver's door).



Incorrect tyre pressures lead to abnormal tyre wear and unusually hot running. These are factors which may seriously affect safety and lead to:

- poor road holding;
- the risk of blow-outs or of throwing a tread.

The pressure depends on the load and the speed of use. Adjust the pressure according to the conditions of use (refer to the label affixed to the edge of the driver's door).

Pressures should be checked when the tyres are cold. Ignore higher pressures which may be reached in hot weather or after driving at high speed.

If tyre pressures cannot be checked when the tyres are **cold, assume an increase of 0.2 to 0.3 bar (or 3 PSI).**

Never deflate a hot tyre.

TYRES



Please be aware that a poorly tightened or missing valve cap can make the tyres less airtight and may lead to pressure loss. Always use valve caps identical to the originals and screw them down fully.

Vehicle fitted with a tyre pressure loss warning system

In the event of under-inflation (punctures, under-inflation etc.), the  warning light appears on the instrument panel → 183.

Emergency spare wheel

→ 351, → 354.

Changing wheels around

This practice is not recommended.

Fitting new tyres



For your safety and to comply with the law. When they need to be replaced, only tyres of the same make, size, type and profile should be used on a single axle.

They must either have a load capacity and speed rating at least equal to those of the original tyres or conform to those recommended by an authorised dealer.

Failure to heed these instructions could endanger your safety and affect your vehicle's roadworthiness.

Risk of loss of control of the vehicle.

Use in winter

Chains

For safety reasons, fitting snow chains to the rear axle is strictly forbidden.

Chains cannot be fitted to tyres which are larger than those originally fitted to the vehicle.

One-way tyres

An one-way tyre must only be fitted in one direction. You must observe this direction.

If an one-way tyre must be fitted in the opposite to its direction of rotation following a puncture, drive with caution, particularly on a wet road, because the tyre specifications will not be adapted.



Chains may only be fitted to tyres of the same size as those originally fitted to **your vehicle**.

"Snow" or "Winter" tyres

We would recommend that these be fitted to all **four wheels** to ensure that your vehicle retains maximum adhesion.

Caution: these tyres sometimes have a specific direction of rotation and a maximum speed index which may be lower than the maximum speed for your vehicle.

Studded tyres

This type of equipment may only be used for a limited period and as laid down by local legislation. It is necessary to observe the speed specified by current legislation.

TYRES

These tyres must, at a minimum, be fitted to the two front wheels.



In all cases, we would recommend that you contact an approved Dealer who will be able to advise you on the choice of equipment which is most suitable for your vehicle.

Tyre pressure

6 Label A



Open the door to read it.

Tyre pressures should be checked when the tyres are cold.

If the tyre pressures cannot be checked when the tyres **are cold**, **increase the values by 0.2 to 0.3 bar (or 3 PSI). Never deflate a hot tyre.**

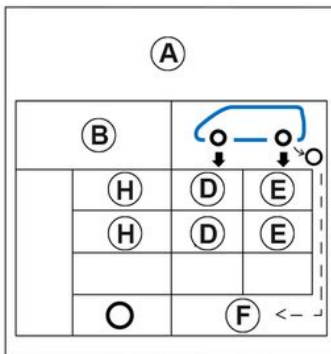

B. : dimension of the tyres fitted to the vehicle.

H. : intended driving speed.

D. : front tyre pressure.

E. : rear tyre pressure.

F. : tyre pressure for the emergency spare wheel.

Vehicle fitted with a tyre pressure loss warning system

In the event of under-inflation (punctures, under-inflation etc.), the  warning light appears on the instrument panel → 183.



Vehicles used fully laden (Maximum Permissible All-up Weight) and towing a trailer

The maximum speed must be limited to **62 mph (100 km/h)** and the **tyre pressure increased by 0.2 bar → 382.**

Risk of tyre blowouts.

Tyre safety and chain fitting: for information on servicing conditions and, depending on the vehicle version, the use of chains → 344.

TYRES



For your safety and to comply with the law. When they need to be replaced, only tyres of the same make, size, type and profile should be used on a single axle.

They must either have a load capacity and speed rating at least equal to those of the original tyres, or conform to those recommended by an approved dealer.

Failure to heed these instructions could endanger your safety and affect your vehicle's roadworthiness.

Risk of loss of control of the vehicle.

Tyre inflation kit



The kit repairs tyres when the tread **A** has been damaged by objects smaller than 6 mm.

It cannot repair all types of puncture, such as cuts larger than 6 mm, cuts in the tyre sidewall **B**, etc.

Ensure also that the wheel rim is in good condition.

Do not pull out the foreign body causing the puncture if it is still in the tyre.



Do not attempt to use the inflation kit if the tyre has been damaged as a result of driving with a

puncture.

You should therefore carefully check the condition of the tyre sidewalls before any operation. Driving with underinflated, flat or punctured tyres can be dangerous and may make the tyre impossible to repair.

This repair is temporary.

A tyre which has been punctured should always be inspected (and repaired, where possible) by a specialist as soon as possible.

When taking a tyre which has been repaired using this kit to be replaced, you must inform the specialist.

When driving, vibration may be felt due to the presence of the repair product injected into the tyre.

TYRES



The kit is only approved for inflating the tyres of the vehicle originally equipped with the kit.

It must never be used to inflate the tyres of another vehicle, or any other inflatable object (rubber ring, rubber boat, etc.).

Avoid spillage on skin when handling the repair product bottle. If droplets do leak out, rinse them off with plenty of water.

Keep the repair kit away from children.

Do not dispose of the empty bottle in the countryside. Return it to your approved dealer or to a recycling organisation.

The bottle has a limited service life which is indicated on its label. Check the expiry date.

Contact an approved dealer to replace the inflation tube and repair product bottle.

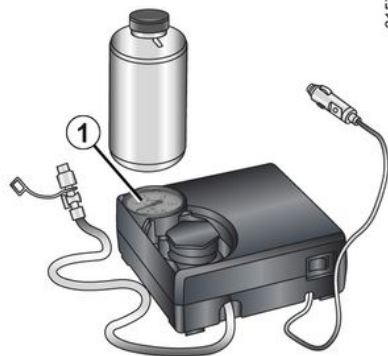

Depending on the vehicle, in the event of a puncture, use the kit located underneath the movable floor in the luggage compartment.

Vehicle fitted with a tyre pressure loss warning system

In the event of under-inflation (punctures, under-inflation etc.), the  warning light appears on the instrument panel → 183.

With the engine running and the parking brake applied:

– disconnect any accessories that are connected to the vehicle's accessories sockets;

– on vehicles fitted with a towing device, disconnect the towbar socket if needed;

– **see the information on the inflation kit compressor** located in the vehicle luggage compartment and follow the instructions for use;

– inflate the tyre to the recommended pressure → 346;

– after a maximum of 15 minutes, stop inflating and read the pressure (on the pressure gauge 1).

Note: while the container is emptying (approximately 30 seconds), the pressure gauge 1 will briefly indicate a pressure up to 6 bar, then the pressure drops;

– adjust the pressure.

If the recommended pressure of 1.8 bar cannot be achieved after 15 minutes, repair is impossible. Do not drive the vehicle. Consult an approved dealer.

TYRES



Before using the kit, park the vehicle at a sufficient distance from traffic, switch on the hazard warning lights, apply the parking brake, ask all passengers to leave the vehicle and keep them away from traffic.



If the vehicle is parked on the hard shoulder, you must warn other road users of your vehicle's presence with a warning triangle or with other devices as per the legislation applying to the country you are in.



Once the tyre is correctly inflated, remove the kit: slowly unscrew the inflation adapter from the container **2** to prevent any product spatter, then store the container in plastic packaging to prevent the product from leaking.

- Affix the driving recommendation label (located under the container) to the dashboard where the driver can see it.
- Put the kit away.
- At the end of this initial inflation operation, air will still escape from the tyre. You must drive a short distance in order to seal the hole.
- Start immediately and drive at a speed between 12 to 37 mph (20 to 60 km/h) in order to distribute the product evenly in the tyre. After driving a dis-

tance of 2 miles (3 km), stop and check the pressure.

- If the pressure is higher than 1.3 bar but lower than the recommended pressure (refer to the label affixed to the edge of the driver's door), adjust it. Otherwise, contact an approved dealer: the tyre cannot be repaired.

Precautions when using the kit

The kit should not be operated for more than 15 consecutive minutes.

The container must be replaced after the first use even if liquid remains inside.



Nothing should be placed around the driver's feet as during sudden braking such objects may slide under the pedals and obstruct their use.

TYRES



Please be aware that a poorly tightened or missing valve cap can make the tyres less airtight and may lead to pressure loss. Always use valve caps identical to the originals and screw them down fully.



Following repair with the kit, do not travel further than 124 miles (200 km). In addition, reduce your speed and under no circumstances exceed 50 mph (80 km/h). The sticker, which you must affix in a prominent position on the dashboard, reminds you of this. Depending on the country or local legislation, a tyre repaired with the inflation kit will need to be replaced.

Tools

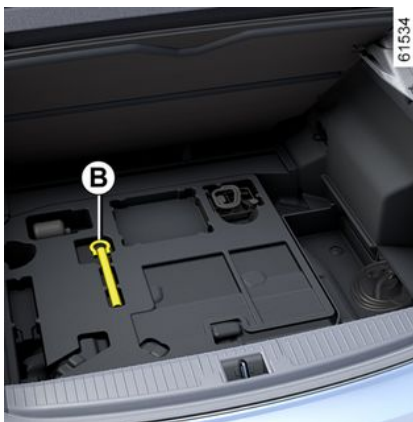

The presence of tools in tool kit **A** or **B** depends on the vehicle.

After use, ensure the tools are correctly stored.



Do not leave the tools unsecured inside the vehicle as they may be projected during braking. After use, check that all the tools are correctly clipped into the tool kit, then position it correctly in its housing to reduce any risk of injury.

If bolts are supplied with the emergency spare wheel, you must use these bolts only for the emergency spare wheel.

TYRES

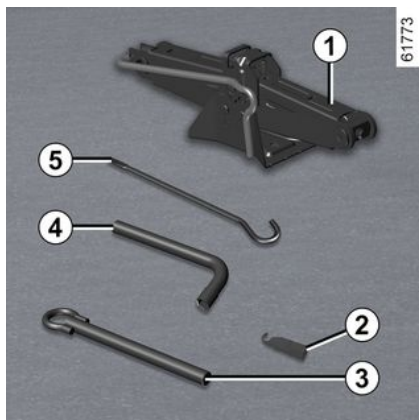

Jack 1

Fold it correctly before refitting it in its housing (ensure that the wheelbrace is correctly positioned).

Wheel bolt guide 2

To finish loosening or starting to tighten the wheel bolts.

Towing eye 3

→ 356

Wheelbrace 4

This can be used to lock or unlock the wheel bolts and the towing eye 5.

Lever 5

This can be used to tighten or loosen the towing eye 3.



For your safety, the use of a jack not recommended by the manufacturer is strictly prohibited.

The jack is specific to the vehicle and used to change the wheels. Under no circumstances should it be used:

- on another vehicle;
- to carry out a repair;
- to access the underside of the vehicle.

Risk of injury.

Risk of damage to the vehicle.

Puncture, emergency spare wheel

In case of puncture



Depending on the vehicle, the following may be available:

- a tyre inflation kit → 347 located under the luggage compartment carpet **A**;

TYRES



6

or

– a tool kit **B** and an emergency spare wheel **C**.

Vehicle fitted with a tyre pressure loss warning system

In the event of under-inflation (punc-

tures, under-inflation etc.), the  warning light appears on the instrument panel → 183.



If the vehicle is parked on the hard shoulder, you must warn other road users of your vehicle's presence with a warning triangle or with other devices as per the legislation applying to the country you are in.

Emergency spare wheel



To get to it:

- open the luggage compartment door;
- lift the mobile floor;

- loosen the central mounting **1** located at the centre of the emergency spare wheel;
- remove the emergency spare wheel.

Note: in the absence of an emergency spare wheel or tyre inflation kit, do not load the bottom of the luggage compartment.



Deactivate the "hands-free" function before handling the emergency spare wheel.

Risk of accidental opening of the tailgate which may cause injury.

TYRES

warnings



If the spare wheel has been stored for several years, have it checked by your Dealer to ensure that it is safe to use.

Vehicle equipped with an emergency spare wheel that differs from the other four wheels:

- Never fit more than one emergency spare wheel to the same vehicle.
- Replace the emergency spare wheel as soon as possible with a wheel identical to the original one.
- When this is fitted to the vehicle, which must only be a temporary measure, the driving speed must not exceed the speed indicated on the label on the wheel.
- Fitting an emergency spare wheel may alter the way the vehicle usually runs. Avoid sudden acceleration or deceleration and reduce your speed when cornering.
- If you need to use snow chains, fit the emergency spare wheel to the rear axle and check the tyre pressure.

TYRES

Changing a wheel

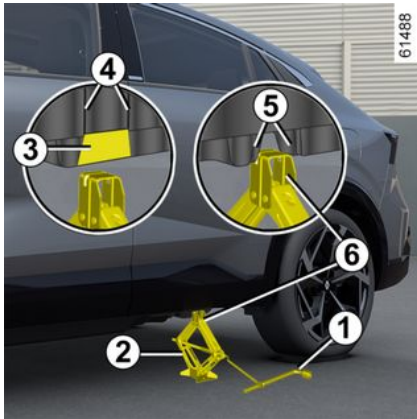

Switch on the hazard warning lights. Keep the vehicle away from traffic and on a level surface where it will not slip. Apply the parking brake and engage a gear (first or reverse, or **P** for automatic transmissions). Ask the passengers to leave the vehicle and to keep away from traffic.

Vehicles equipped with a jack and wheel brace

If necessary, remove the wheel trim.

Unlock the wheel bolts using the wheel brace **1**. Position it so as to be able to push from above.

Position the jack **2** horizontally: the jack head **must** be lined up with the sill closest to the wheel concerned, between the marks **4**.

If changing a rear wheel, before positioning the jack, remove the cover **3** by pulling it downwards (once the wheel change is complete, do not forget to refit the cover **3**).

The cover **3** is present on both sides of the vehicle.

Start cranking the jack by hand, positioning the jack support plate **6** plate in the slightly indented groove underneath the vehicle, located between the two notches **5** and in the direction of the arrow **3**.

Continue to crank the jack so that the baseplate is correctly positioned (it should be underneath the vehicle and aligned with the jack head).

Turn it a few times to lift the wheel off the ground.



If the vehicle is parked on the hard shoulder, you must warn other road users of your vehicle's presence with a warning triangle or with other devices as per the legislation applying to the country you are in.

Undo the bolts and take off the wheel. Fit the emergency spare wheel on the central hub and turn it to locate the mounting holes in the wheel and the hub.

Tighten the bolts, checking that the wheel is correctly positioned on its hub.

Lower the jack.

With the wheel on the ground, tighten the bolts fully and have the tightness of the bolts checked and the emergency spare wheel pressure checked as soon as possible.

TYRES



If you have a puncture, replace the wheel as soon as possible.

A tyre which has been punctured should always be inspected (and repaired, where possible) by a specialist.

Vehicle fitted with a tyre pressure loss warning system

In the event of under-inflation (punctures, under-inflation etc.), the  warning light appears on the instrument panel ➔ 183.



Do not leave the tools unsecured inside the vehicle as they may be projected during braking.

After use, check that all the tools are correctly clipped into the tool kit, then position it correctly in its housing to reduce any risk of injury.

If bolts are supplied with the emergency spare wheel, you must use these bolts only for the emergency spare wheel.



For your safety, the use of a jack not recommended by the manufacturer is strictly prohibited.

The jack is specific to the vehicle and used to change the wheels. Under no circumstances should it be used:

- on another vehicle;
- to carry out a repair;
- to access the underside of the vehicle.

Risk of injury.

Risk of damage to the vehicle.

BREAKDOWN RECOVERY

Towing: breakdown

Before towing, set the gearbox to **N** position, unlock the steering column then release the parking brake.

The speed specified by current legislation for towing must always be observed.

If you are driving the towing vehicle, do not exceed the maximum towing weight for your vehicle → **382**.

To recover a vehicle on a flatbed or tow the vehicle using a towing point, observe the following instructions:

- with the card in the passenger compartment, press the engine start button;
- position the lever in **N** → **163** position: the steering column is unlocked and the parking brake is released;
- press the engine Start button for more than two seconds. The accessories functions are supplied: you can use the vehicle lighting functions (direction indicators, brake lights, etc.). At night the vehicle lights must be on;
- once you have finished towing, press the engine start button for more than two seconds (risk of discharging the battery).



Leave the card in the vehicle during towing.
Risk of the steering column locking.



Do not leave the tools unsecured inside the vehicle as they may be projected during braking.



Do not leave the tools unsecured inside the vehicle as they may be projected during braking.

Only use the front **4** and rear **8** towing points.

(never use the drive shafts or any other part of the vehicle). These towing points may only be used for pulling. They must never be used for lifting the vehicle directly or indirectly.

Towing a vehicle fitted with an automatic gearbox

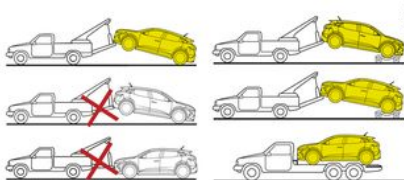

Transport the vehicle on a trailer or tow it with the front wheels off the ground.

E-Tech plug-in hybrid vehicles must **only** be transported with the wheels off the ground.



When the engine is stopped, steering and braking assistance are no longer provided.

BREAKDOWN RECOVERY

Access to towing points

Front towing point 4

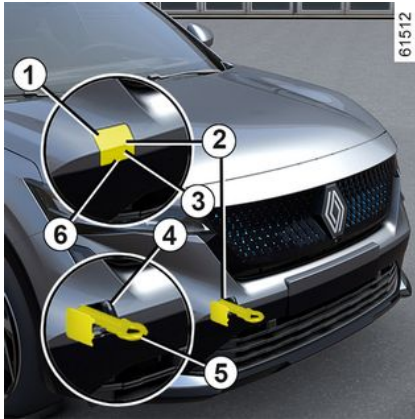

Press zone **1** and keep the pressure on while pulling zone **3** to open the flap **2**.

Depending on the vehicle, to open the flap **2** it may be necessary to insert the "hands-free" card's built in key into the notch **6** in order to pull it → **62**.

Rear towing point 8

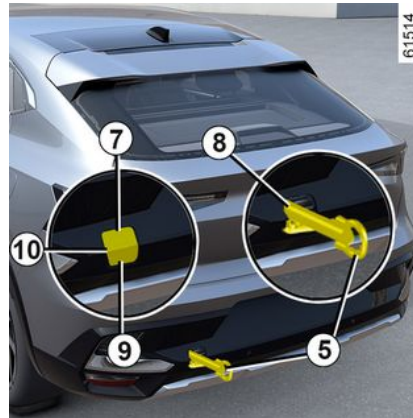

Press zone **9** and keep the pressure on while pulling zone **7** to open the flap **10**.

Tighten the towing eye 5 fully: first by hand as far as possible, then finish by locking it using the wheelbrace or, depending on the vehicle, the lever.

You must only use the towing ring **5** and the wheel brace or the lever stored with the tools → **350**.



Ensure that the towing ring is bolted correctly.
Risk of losing the towed object.



- Use a rigid tow bar. If a rope or cable is used (where the law allows this), the vehicle being towed must be able to brake.
- a vehicle must not be towed if it is not fit to be driven.
- avoid accelerating or braking suddenly when towing, as this may result in damage being caused to the vehicle.
- In any case, it is advisable not to exceed **16 mph (25 km/h)**.



Do not leave the tools unsecured inside the vehicle as they may be projected during braking.

Battery: breakdown recovery

To avoid all risk of sparks:

- Ensure that the "energy consumers" (ceiling lights, etc.) are switched off before disconnecting or reconnecting a battery;

BREAKDOWN RECOVERY

- when charging, switch off the charger before connecting or disconnecting the battery;
- do not place any metal objects on the battery as this may create a short circuit across the terminals;
- wait for at least five minutes after switching off the engine before disconnecting the battery;
- make sure that you reconnect the battery terminals after refitting.



Depending on the vehicle, in the event of a battery fault (disconnected, discharged battery, etc.), a reset of the power-assisted steering must be carried out → 139.



Before carrying out any action in the engine compartment, you must switch off the ignition

→ 160.

Connecting a battery charger

The battery charger must be compatible with a battery with nominal voltage of 12 volts.

Do not disconnect the battery while the engine is running. **Follow the instructions given by the manufacturer of the battery charger you are using.**



Special procedures may be required to charge some batteries. Contact your approved dealer.

Avoid all risk of sparks which may cause an immediate explosion, and charge the battery in a well ventilated area.

Risk of serious injury.



Handle the battery with care as it contains sulphuric acid which must not come into contact with the eyes or skin. If it does, wash the affected area with plenty of cold water. If necessary, consult a doctor.

Keep any flames, red hot objects or sparks away from the battery components (**risk of explosion**). Please note when working close to the engine that it may be hot. The engine cooling fan may also start at any moment. The warning

light  in the engine compartment reminds you of this.

Risk of injury.

Starting the vehicle using the battery from another vehicle

If you have to use the battery from another vehicle to start, obtain suitable jump leads (with a large cross section) from an approved dealer or, if you already have jump leads, ensure that they are in perfect condition.

The two batteries must have an identical nominal voltage: 12 V. The

BREAKDOWN RECOVERY

battery supplying the current should have a capacity (amp-hours, Ah) which is at least the same as that of the discharged battery.

Ensure that there is no risk of contact between the two vehicles (risk of short circuiting when the positive terminals are connected) and that the discharged battery is properly connected. Switch off your vehicle ignition.

Note: as the battery cannot be directly accessed, it is necessary to use the remote terminals located in the engine compartment.

 Do not use your E-tech full hybrid or E-Tech plug-in hybrid vehicle to restart another vehicle's "12 V" battery. The electrical power of a secondary "12 V" battery in a E-tech full hybrid or E-Tech plug-in hybrid vehicle is insufficient for this operation.

Risk of damage to the vehicle.



Handle the battery with care as it contains sulphuric acid which must not come into contact with the eyes or skin. If it does, wash the affected area with plenty of cold water. If necessary, consult a doctor.

Keep any flames or sparks away from the battery components (**risk of explosion**). Please note when working close to the engine that it may be hot. The engine cooling fan may also

start at any moment. The  label in the engine compartment reminds you of this.

Risk of injury.

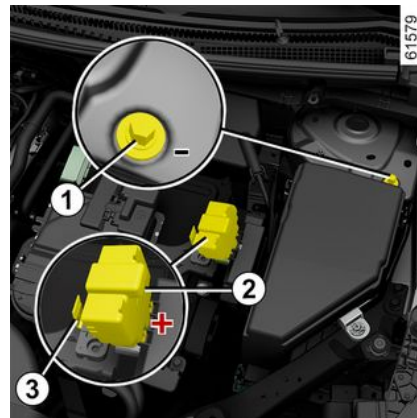

The battery is not directly accessible. You must use the remote terminals.

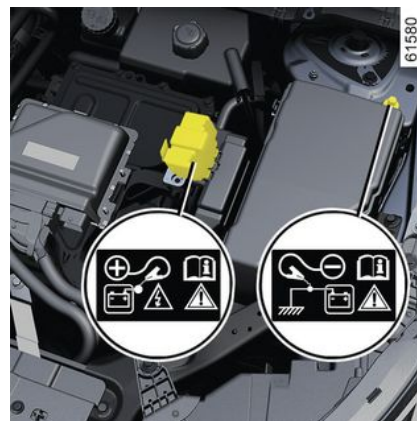

6

BREAKDOWN RECOVERY

Use **terminal 1 (-)** and **terminal 2 (+)** in the engine compartment.

Raise the cover **3** of **terminal 2 (+)**.



It is forbidden to disconnect the positive cable in the engine compartment.

Risk of the engine starting inadvertently.
Risk of burns by projection of sparks.

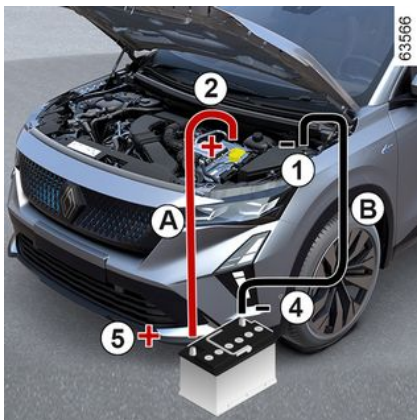

Attach the positive cable **A** to **terminal 2 (+)**, then to **terminal 5 (+)** of the battery supplying the current.

Attach the negative cable **B** to **terminal 4 (-)** of the battery supplying the current then to **terminal 1 (-)**.

Start the engine of the vehicle and run it at an intermediate engine speed.

If your vehicle's engine does not start immediately, switch off the ignition and wait a few seconds before repeating the operation.

With the engine running, disconnect cables **A** and **B** in the reverse order (**1 - 4 - 5 - 2**).

Reposition the cover **3** of **terminal 2 (+)**.



Ensure that there is no contact between cables **A** and **B** and that positive cable **A** is not in contact with any metallic component in the vehicle supplying the current.

Risk of injury and/or damage to the vehicle.

HEADLIGHTS, LIGHTS: REPLACING BULBS

Exterior lighting: replacing bulbs

Front headlights

Changing bulbs



Your vehicle is fitted with LED lights, contact an Approved Dealer to have them replaced.

LED dipped beam/main beam headlights 1

Consult an approved dealer.

LED daytime running lights/side lights/direction indicators 2

Consult an approved dealer.

Rear and indicator lights

Changing bulbs

LED side light/brake light 1

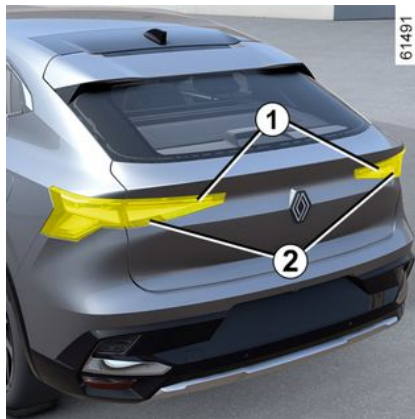

Consult an approved dealer.

LED direction indicator lights 2

LED direction indicator lights 2

LED reversing lights and fog lights 3



Consult an approved dealer.

6

HEADLIGHTS, LIGHTS: REPLACING BULBS

LED high-level brake light 4



Consult an approved dealer.

LED number plate lights 5



Consult an approved dealer.

LED side repeaters 6

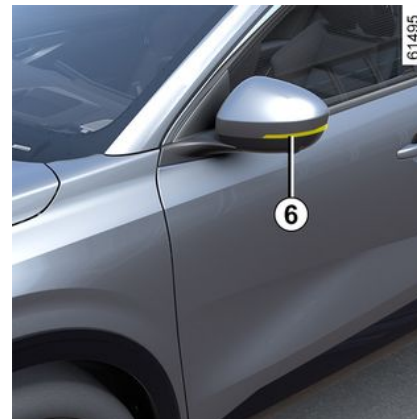

Consult an approved dealer.

HEADLIGHTS, LIGHTS: REPLACING BULBS

Interior lighting: changing bulbs

Consult an approved dealer.

Reading lights 1, 2 and 3

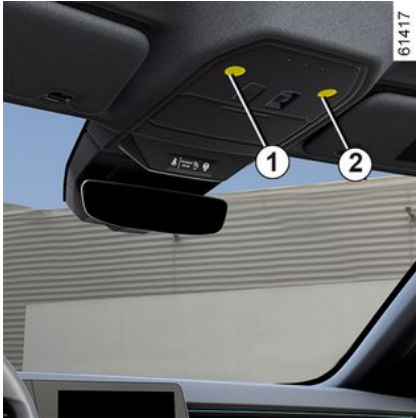

Light for luggage compartment 5



Consult an approved dealer.

WIPER BLADES: REPLACEMENT

Replacing the windscreen wiper blades 2



To replace the wipers, first put them in the service position **B**.

With the ignition on and the engine stopped:

- move the stalk **1** twice in succession to position **A** (single sweep): the wiper blades will stop in the service position **B** away from the bonnet;
- lift the wiper arm **3**;
- lower the tab **4** and remove the blade **2**.

Refitting

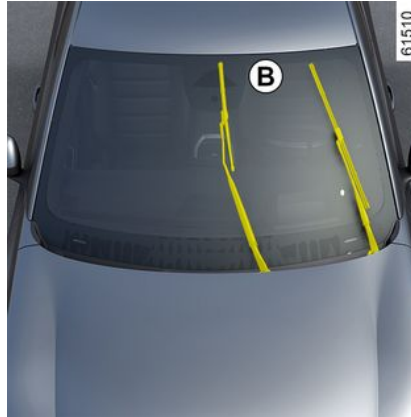

To refit the wiper blade **2**, insert it into its housing in the arm **3**, then clip it until you hear a click. Make sure that the blade is correctly locked in position.

To return the blades to the lowered position, make sure that the blades are folded down onto the windscreen then set the stalk **1** to position **A** (single sweep): the windscreen wiper blades will fold into the bonnet when the ignition is switched on.

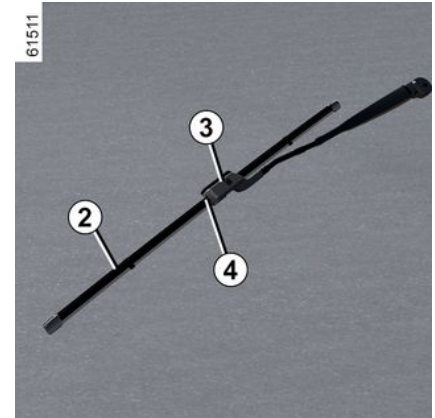

i Check the condition of the wiper blades. You are responsible for their service life:

- clean the blades, windscreen and rear screen regularly with soapy water;
- do not use them when the windscreen or rear screen is dry;
- free them from the windscreen or rear screen when they have not been used for a long time.

FUSES

Fuse boxes

If any electrical component does not work, check the condition of the fuses.

Fuses in the passenger compartment **A**



Unclip the flap **1**.



To comply with current legislation, or as a precaution, you can obtain an emergency kit from your approved dealer containing a set of spare bulbs and fuses.

Fuses in the passenger compartment **B**

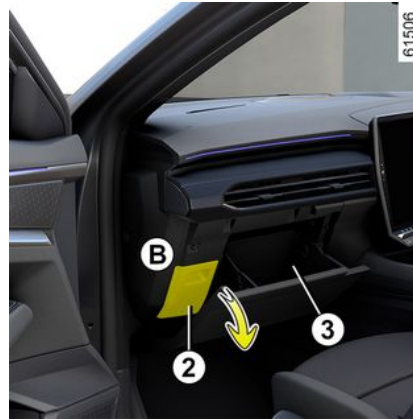

The fuses are located behind a flap **2** in the glovebox **3**.

Unclip the flap **2**.



Check the fuse in question and, **if necessary, replace it (replacement fuse must have the same rating as the original.**

If a fuse is fitted with too high a rating, it may cause the electrical circuit to overheat (risk of fire) in the event of an item of equipment using an excessive amount of current.



Disconnect the fuse using the lever **4** located on the fuse panel.









FUSES



Do not pull the component **5** (risk of some vehicle equipment being deactivated).

Replacement fuses are available in zone **6**.

Allocation of fuses

(the presence of certain fuse depends on the vehicle equipment level)

Icon	Allocation
	Screen washer pump (depending on the vehicle)
	Rear windscreen wiper
	Multimedia accessories socket
	Cigarette lighter socket
	Towbar socket
	One-touch electric windows
	Brake lights
	Passenger compartment ECU

Icon	Allocation
	Direction indicator lights (depending on the vehicle)
	Luggage compartment accessories socket

 Use the fuse allocation label in the storage compartment to identify the fuses.

Passenger compartment **A**: the fuse allocation label can be found on the rear side of the flap **1**.

Passenger compartment **B**: the fuse allocation label can be found behind the glovebox **3**.

Certain fuses should only be replaced by a qualified professional. These fuses are not listed on the label.

Only change the fuses represented on the label.

Fuses in the engine compartment **C**



Some functions are protected by fuses located in the engine compartment (unit **C**).

However, because of their reduced accessibility, **we advise you to have your fuses replaced by an approved Dealer.**

Fuses underneath the rear floor **D**
(depending on the vehicle)

FUSES



For safety reasons, it is forbidden to open the fuse compartment located underneath the flap **D**.



Please note when working close to the engine that it may be hot. The engine cooling fan may also start at any moment. The



label in the engine compartment reminds you of this.

Risk of injury.



Before carrying out any action in the engine compartment, you must switch off the ignition

→ 160.



Electrical and electronic accessories

Before installing this type of accessory (particularly for transmitters/receivers: frequency bandwidth, power level, position of the aerial, etc.), make sure it is compatible with your vehicle. Contact an approved dealer.

Before connecting an accessory to a port, ensure that it does not exceed the maximum power authorised for the socket concerned → 315, → 321.

Fire hazard.

No work may be carried out on the vehicle's electrical and/or electronic circuits, except by a qualified professional. In fact, an incorrect connection and/or the installation of electrical/electronic accessories not approved by the manufacturer could lead to:

- damage to the electrical and/or electronic equipment;
- damage to the components connected to it;
- the collection and use of vehicle data;
- an invasion of privacy (modification, deletion or unwarranted access to personal data);
- cancellation of the authorisation for entry into service.

Risk of serious accidents.

Risk of invasion of privacy.

If you have electrical equipment fitted in future, make sure that you obtain information on the rating and position of this fuse.

Using the diagnostic socket

The use of electronic accessories on the diagnostic socket may cause serious disturbance to the vehicle's electronic systems. For your safety, we recommend that you only use electronic accessories approved by the manufacturer: consult an approved dealer.

Risk of serious accidents

Fitting aftermarket accessories

If you wish to install accessories on the vehicle: consult an approved dealer. Also, to ensure the correct operation of your vehicle, and to avoid any risk to your safety, we recommend that you use only accessories specifically designed for your vehicle, which are the only accessories for which the manufacturer will provide a warranty.

If you are using an anti-theft device, only attach it to the brake pedal.

Driver obstruction

INSTALLATION AND USE OF ACCESSORIES

On the driver's side, only use mats suitable for the vehicle, attached with the pre-fitted components, and check the fitting regularly. Do not lay one mat on top of another.

There is a risk of wedging the pedals.

OPERATING FAULTS

The following advice will enable you to carry out quick, temporary repairs. For safety reasons you should always contact an approved Dealer as soon as possible.

Using the card	POSSIBLE CAUSES	ACTION REQUIRED
The card does not lock or unlock the doors.	Card battery is flat.	Replace the battery. You will still be able to lock/unlock, and start your vehicle → 62 and/or → 160.
	Use of appliances operating on the same frequency as the card (mobile phone, etc.).	Stop using the devices or use the built-in key → 62.
	Vehicle located in a high electromagnetic radiation zone.	Use the key that is built into the card → 62.
	Vehicle battery flat.	
	The vehicle is started.	While the engine is on, it is not possible to lock/unlock using the card. Turn off the ignition.
The "Place card in zone + START" message appears on the instrument panel.	Desynchronisation of the card	Unlock the driver's door by inserting the card's built-in key into the door lock → 62, then place the card on the placement area → 160 and press the START button to synchronise the card.

The starter is activated	POSSIBLE CAUSES	ACTION REQUIRED
The instrument panel indicator lights are weak or fail to light up and the starter does not turn.	Battery terminals not tight, battery terminals disconnected or oxidised.	Retighten, reconnect or clean them if they are oxidised.
	Discharged battery or not operational.	Connect another battery to the faulty battery → 339 or replace the battery if necessary. Do not push the vehicle if the steering column is locked.
	Faulty circuit.	Consult an approved dealer.

OPERATING FAULTS

The starter is activated	POSSIBLE CAUSES	ACTION REQUIRED
The engine will not start.	Starting conditions are not fulfilled. The "hands-free" card does not work.	➔ 160. Place the card in the recess provided for this purpose on the centre console or ➔ 160.
With the vehicle stationary, engine cold, the engine's idle speed is high.	Petrol version, this is not necessarily a fault. This may be caused by the increase in the engine temperature.	The engine's idle speed should decrease after about one minute. Otherwise, this may be caused by another fault. Call an approved dealer.

The starter is activated	POSSIBLE CAUSES	ACTION REQUIRED
The engine cannot be switched off.	Card not detected. Electronic fault.	Place the card in the recess provided for this purpose on the centre console. Press and hold the engine start button. Press three times in quick succession or press and hold the engine start button. Special feature of the E-Tech full hybrid vehicle: after stopping the engine, if the automatic gearbox does not automatically engage P position, messages will appear on the instrument panel to warn you. It will then be necessary to press the engine start button. If the messages persist, stop the engine by pressing the engine stop button. Lock the vehicle with the card, wait approximately five minutes, then unlock the vehicle using the card and finally press the engine start button again. If the problem persists, check that the electronic parking brake is applied and contact an approved dealer.
The steering column remains locked.	Steering wheel locked.	Move the steering wheel while pressing the engine start button.

OPERATING FAULTS

The starter is activated	POSSIBLE CAUSES	ACTION REQUIRED
	Faulty electrical circuit.	Consult an approved dealer.

On the road	POSSIBLE CAUSES	ACTION REQUIRED
Vibrations.	Tyres not inflated to the correct pressure, incorrectly balanced or damaged.	Check the tyre pressures: if this is not the cause, have their condition checked by an approved dealer.
White smoke from the exhaust.	This is not necessarily a fault. Depending on the climate conditions (cold, humidity etc.), smoke may be produced under hard vehicle acceleration.	Reduce the engine speed and avoid sudden acceleration to gradually make the smoke disappear. Otherwise, this may be caused by another fault. Consult an approved dealer.
Smoke under the bonnet.	Short-circuit or cooling system leak.	Stop, switch off the ignition, stand away from the vehicle and contact an approved dealer.
The oil pressure warning light comes on:		
while cornering or braking.	The level is too low.	Add engine oil → 332 .
is slow to go out or remains lit up under acceleration.	Loss of oil pressure.	Stop the vehicle and contact an approved dealer.

On the road	POSSIBLE CAUSES	ACTION REQUIRED
Steering becomes heavy.	Assistance overheating.	Drive carefully at reduced speed, be aware of the level of force in the steering wheel needed to turn the wheels.

OPERATING FAULTS

On the road	POSSIBLE CAUSES	ACTION REQUIRED
	Fault with the electric assistance motor. Fault in the assistance system	Consult an approved dealer.
The engine is overheating. The coolant temperature indicator is in the warning zone and warning light STOP comes on.	Engine cooling fan not working.	Stop the vehicle, switch off the engine and contact an approved dealer.
	Coolant leaks.	Check the coolant reservoir: it should contain fluid. If there is no coolant, consult an approved dealer as soon as possible.
Coolant boiling in the coolant reservoir.	Mechanical fault: damaged cylinder head gasket.	Stop the engine. Call an approved dealer.



Radiator: in the event of a significant lack of coolant, remember that you must never top up using cold coolant while the engine is very hot. After any procedure on the vehicle which has involved even partial draining of the cooling system, it must be refilled with a new mixture prepared in the correct proportions. Reminder: only products approved by our Technical Department may be used for this purpose.

Electrical equipment	POSSIBLE CAUSES	ACTION REQUIRED
The wipers do not work.	Wiper blades stuck.	Free the blades before using the wipers.
	Faulty electrical circuit.	Consult an approved dealer.
	Fuse damaged.	Replace the fuse or have it replaced → 365.

OPERATING FAULTS

Electrical equipment	POSSIBLE CAUSES	ACTION REQUIRED
The wiper does not stop.	Faulty electrical controls.	Consult an approved dealer.
Direction indicators flashing more quickly.	Faulty bulb.	→ 361.
The indicators are not working.	Faulty electrical circuit or control. Faulty bulb.	Consult an approved dealer.
	Fuse damaged.	Replace the fuse or have it replaced → 365.
The headlights do not switch on or off.	Faulty electrical circuit or control. Faulty bulb.	Consult an approved dealer.
	Fuse damaged.	Replace the fuse or have it replaced → 365.

6

Electrical equipment	POSSIBLE CAUSES	ACTION REQUIRED
Traces of condensation in the headlights or rear lights.	Traces of condensation may be a natural phenomenon caused by variations in temperature and humidity. In this case, the traces will disappear slowly once the lights are switched on.	
The front seat belt reminder warning light comes on when the seat belts are fastened.	An object is stuck between the floor and the seat and is disrupting the operation of the sensor.	Remove all objects from underneath the front seats.

INFORMATION ABOUT THE VEHICLE

Vehicle identification plates

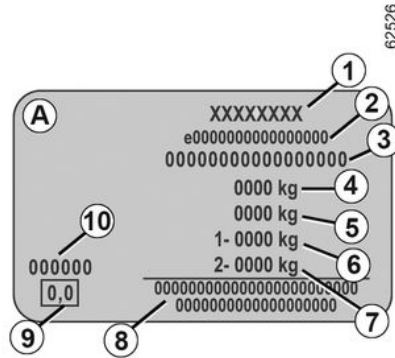
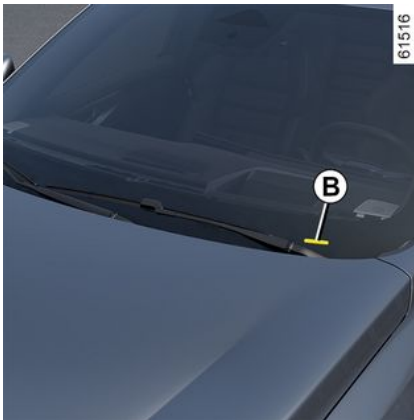

5. MTR (Gross Train Weight: vehicle fully loaded, with trailer).

6. MMTA (Maximum Permissible Weight) on front axle.

7. MMTA on rear axle.

8. Reserved for related or additional entries.

9. Not used.

10. Paint reference (colour code).

Technical Information for the emergency services

The information shown on the vehicle identification plate should be quoted on all correspondence or orders.

The presence and location of the information depends on the vehicle.

Identification plate A

1. Manufacturer name.

2. EC design number or approval number.

3. Identification number.

Depending on the vehicle, this information is also provided on marking B.

4. MMAC (Maximum Permissible All-up Weight).



INFORMATION ABOUT THE VEHICLE

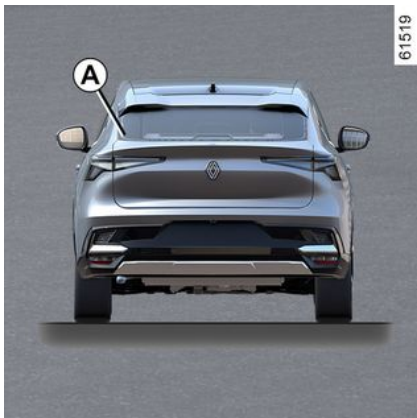

7 The QR Code on label **A** allows emergency workers using a tablet or smart-phone to immediately access the technical information useful for working on the vehicle in the event of an accident.

Ensure that the label **A** is always visible and present on the windscreen as well as the rear screen.

Any modification or damage would prevent access to the information.

Engine identification, engine specifications

Engine identification

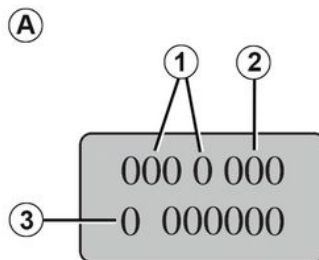

Please quote the engine identification information provided in zone **A in all correspondence or orders.**

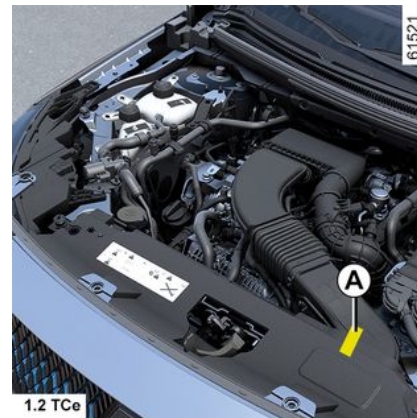

1. Engine type.
2. Engine suffix.
3. Engine serial number.

INFORMATION ABOUT THE VEHICLE

Engine specifications

Versions	E-Tech plug-in hybrid		E-tech full hybrid	
Engine type (see engine plate)	H5F Turbo	5DH	H5F Turbo	5DH
Cubic capacity (cc)	1 199	-	1 199	-
Type of fuel Octane rating	Petrol It is essential to use unleaded petrol with an octane rating matching that indicated on the label affixed on the fuel filler flap ➔ 155 .			

INFORMATION ABOUT THE VEHICLE

Versions	E-Tech plug-in hybrid	E-tech full hybrid
<p>Fuel types that meet European standards and are compatible with the engines of vehicles sold in Europe (in any other case, contact an Approved Dealer).</p>		<p>Unleaded petrol compliant with standard EN 228 containing up to 5% ethanol in volume.</p>
<p>7</p>		

INFORMATION ABOUT THE VEHICLE

Versions	E-Tech plug-in hybrid	E-tech full hybrid
	 <p data-bbox="899 393 1418 443">Unleaded petrol compliant with standard EN 228 containing up to 10% ethanol in volume.</p>	
Spark plugs	<p data-bbox="355 701 994 725">Only use the spark plugs specified for your vehicle's engine.</p> <p data-bbox="355 734 1418 785">The type should be marked on a label affixed inside the engine compartment. If it is not then contact an approved Dealer.</p> <p data-bbox="355 794 1135 818">Fitting spark plugs which are not to specification may damage the engine.</p>	

INFORMATION ABOUT THE VEHICLE

Dimensions (in metres)

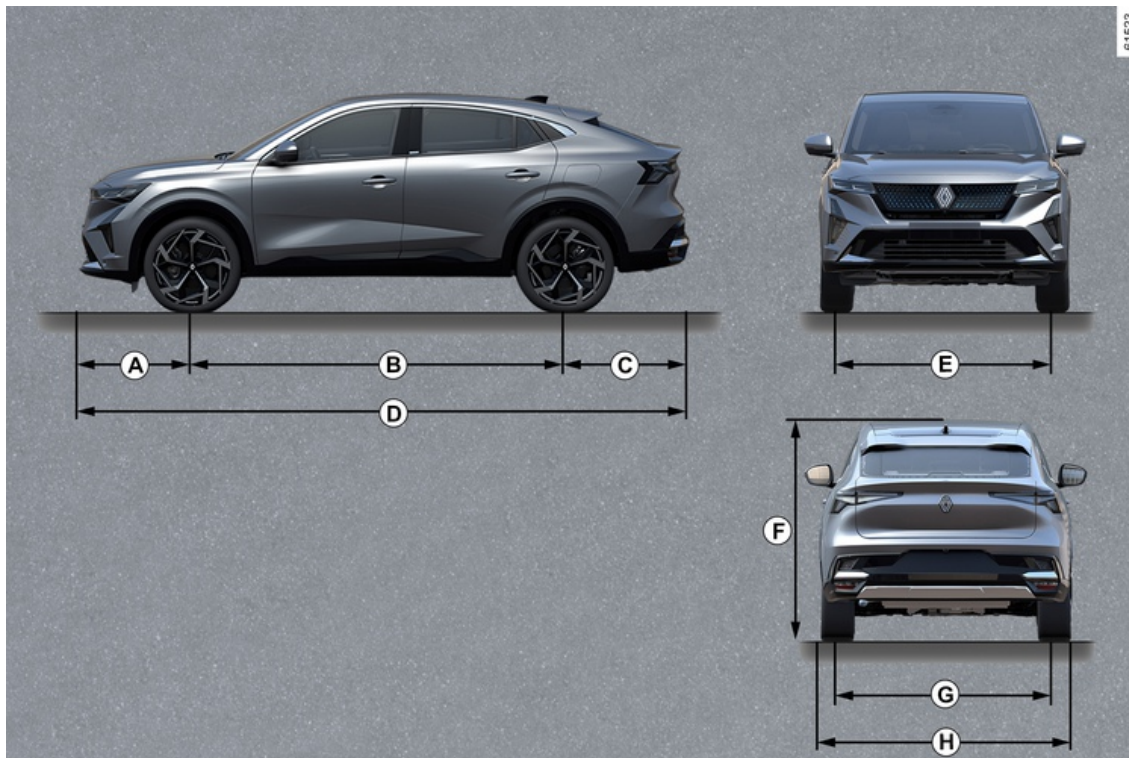

7

INFORMATION ABOUT THE VEHICLE

	Length
A	0,946
B	2,739
C	1,027
D	4,712
E	1,594
F	1.613 unladen, vehicle fitted with a rigid antenna
G	1,616
H	1,843 1.863 with door mirrors folded in 2.083 with door mirrors folded out

INFORMATION ABOUT THE VEHICLE

Weights (in kg)

The weights indicated are for a basic vehicle without optional fittings: they vary according to your vehicle's equipment. Consult your approved Dealer.	
Maximum Permissible All-Up Weight (MMAC) Maximum Permissible Weight (MMTA) Gross Train Weight (MTR)	Weights indicated on the manufacturer's plate → 375
Braked Towing Weight *	found by calculating: MTR - MMAC
Unbraked Towing Weight *	750
Permissible nose weight *	75
Maximum permissible load on roof	80 (including carrying device)
<p>* Towing weight (towing a caravan, boat, etc.)</p> <p>Towing is prohibited when the MTR - MMAC calculation is equal to zero, or when the MTR is equal to zero (or is not indicated) on the manufacturer's plate.</p> <ul style="list-style-type: none">– It is important to respect local towing regulations in force, specifically those set out in the Highway Code. Contact an approved Dealer for any modifications to towing equipment.– For vehicles fitted with a trailer, the total train weight (vehicle + trailer) must never be exceeded. However the following is tolerated:<ul style="list-style-type: none">– rear MMTA exceeded by up to 15%;– MMAC exceeded by up to 10% or 100 kg (whichever limit is reached first). <p>In either case, the maximum speed of the vehicle and trailer must not exceed 62 mph (100 km/h) and the tyre pressures must be increased by 0.2 bar (3 psi).</p> <ul style="list-style-type: none">– The engine output and climbing capability are reduced with altitude. We recommend that the maximum load be reduced by 10% at an altitude of 1,000 metres and by an additional 10% for each 1,000 metres thereafter.	

REPLACEMENT PARTS AND REPAIRS

Original parts are based on very stringent specifications and are subjected to specific tests. Therefore, they are of at least the same level of quality as the parts fitted originally.

If you always fit genuine replacement parts to your vehicle, you will ensure that it performs well. Furthermore, repairs carried out in the approved dealer network with original parts are guaranteed according to the conditions stated on the back of the repair order.

SERVICE SHEETS

VIN:

Date:	Miles (km):	Invoice number:	Comments/miscellaneous
Type of operation:		Stamp	
Service <input type="checkbox"/>			
..... <input type="checkbox"/>			
Anticorrosion check:			
OK <input type="checkbox"/> Not OK* <input type="checkbox"/>			
Date:	Miles (km):	Invoice number:	Comments/miscellaneous
Type of operation:		Stamp	
Service <input type="checkbox"/>			
..... <input type="checkbox"/>			
Anticorrosion check:			
OK <input type="checkbox"/> Not OK* <input type="checkbox"/>			
Date:	Miles (km):	Invoice number:	Comments/miscellaneous
Type of operation:		Stamp	
Service <input type="checkbox"/>			
..... <input type="checkbox"/>			
Anticorrosion check:			
OK <input type="checkbox"/> Not OK* <input type="checkbox"/>			

* See specific page

SERVICE SHEETS

VIN:

Date:	Miles (km):	Invoice number:	Comments/miscellaneous
Type of operation: Service <input type="checkbox"/> <input type="checkbox"/>		Stamp	
Anticorrosion check: OK <input type="checkbox"/> Not OK* <input type="checkbox"/>			
Date:	Miles (km):	Invoice number:	Comments/miscellaneous
Type of operation: Service <input type="checkbox"/> <input type="checkbox"/>		Stamp	
Anticorrosion check: OK <input type="checkbox"/> Not OK* <input type="checkbox"/>			
Date:	Miles (km):	Invoice number:	Comments/miscellaneous
Type of operation: Service <input type="checkbox"/> <input type="checkbox"/>		Stamp	
Anticorrosion check: OK <input type="checkbox"/> Not OK* <input type="checkbox"/>			

* See specific page

SERVICE SHEETS

VIN:

Date:	Miles (km):	Invoice number:	Comments/miscellaneous
Type of operation: Service <input type="checkbox"/> <input type="checkbox"/>		Stamp	
Anticorrosion check: OK <input type="checkbox"/> Not OK* <input type="checkbox"/>			
Date:	Miles (km):	Invoice number:	Comments/miscellaneous
Type of operation: Service <input type="checkbox"/> <input type="checkbox"/>		Stamp	
Anticorrosion check: OK <input type="checkbox"/> Not OK* <input type="checkbox"/>			
Date:	Miles (km):	Invoice number:	Comments/miscellaneous
Type of operation: Service <input type="checkbox"/> <input type="checkbox"/>		Stamp	
Anticorrosion check: OK <input type="checkbox"/> Not OK* <input type="checkbox"/>			

7

* See specific page

SERVICE SHEETS

VIN:

Date:	Miles (km):	Invoice number:	Comments/miscellaneous
Type of operation: Service <input type="checkbox"/> <input type="checkbox"/>		Stamp	
Anticorrosion check: OK <input type="checkbox"/> Not OK* <input type="checkbox"/>			
Date:	Miles (km):	Invoice number:	Comments/miscellaneous
Type of operation: Service <input type="checkbox"/> <input type="checkbox"/>		Stamp	
Anticorrosion check: OK <input type="checkbox"/> Not OK* <input type="checkbox"/>			
Date:	Miles (km):	Invoice number:	Comments/miscellaneous
Type of operation: Service <input type="checkbox"/> <input type="checkbox"/>		Stamp	
Anticorrosion check: OK <input type="checkbox"/> Not OK* <input type="checkbox"/>			

* See specific page

SERVICE SHEETS

VIN:

Date:	Miles (km):	Invoice number:	Comments/miscellaneous
Type of operation:		Stamp	
Service <input type="checkbox"/>			
..... <input type="checkbox"/>			
Anticorrosion check:			
OK <input type="checkbox"/> Not OK* <input type="checkbox"/>			
Date:	Miles (km):	Invoice number:	Comments/miscellaneous
Type of operation:		Stamp	
Service <input type="checkbox"/>			
..... <input type="checkbox"/>			
Anticorrosion check:			
OK <input type="checkbox"/> Not OK* <input type="checkbox"/>			
Date:	Miles (km):	Invoice number:	Comments/miscellaneous
Type of operation:		Stamp	
Service <input type="checkbox"/>			
..... <input type="checkbox"/>			
Anticorrosion check:			
OK <input type="checkbox"/> Not OK* <input type="checkbox"/>			

* See specific page

SERVICE SHEETS

VIN:

Date:	Miles (km):	Invoice number:	Comments/miscellaneous
Type of operation: Service <input type="checkbox"/> <input type="checkbox"/>		Stamp	
Anticorrosion check: OK <input type="checkbox"/> Not OK* <input type="checkbox"/>			
Date:	Miles (km):	Invoice number:	Comments/miscellaneous
Type of operation: Service <input type="checkbox"/> <input type="checkbox"/>		Stamp	
Anticorrosion check: OK <input type="checkbox"/> Not OK* <input type="checkbox"/>			
Date:	Miles (km):	Invoice number:	Comments/miscellaneous
Type of operation: Service <input type="checkbox"/> <input type="checkbox"/>		Stamp	
Anticorrosion check: OK <input type="checkbox"/> Not OK* <input type="checkbox"/>			

* See specific page

ANTICORROSION CHECK

If the continuation of the warranty is subject to repair, it is indicated below.

VIN:

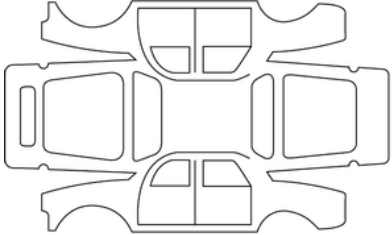
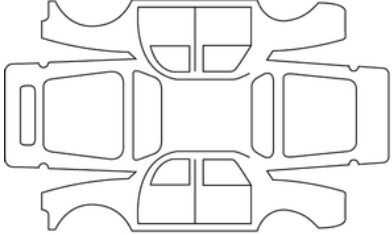
Date of repair:		Stamp
Corrosion repair operation to be carried out:		
Date of repair:		Stamp
Repair to be carried out:		

7

ANTICORROSION CHECK

If the continuation of the warranty is subject to repair, it is indicated below.

VIN:

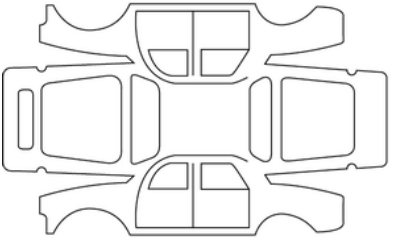
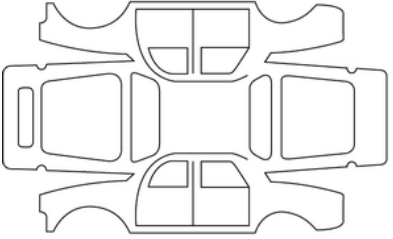
Date of repair:		Stamp
Corrosion repair operation to be carried out:		
Date of repair:		Stamp
Repair to be carried out:		

ANTICORROSION CHECK

If the continuation of the warranty is subject to repair, it is indicated below.

VIN:

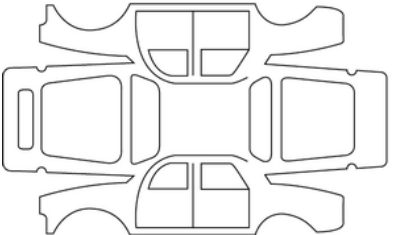
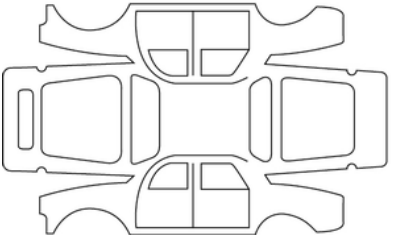
Date of repair:		Stamp
Corrosion repair operation to be carried out:		
Date of repair:		Stamp
Repair to be carried out:		

7

ANTICORROSION CHECK

If the continuation of the warranty is subject to repair, it is indicated below.

VIN:

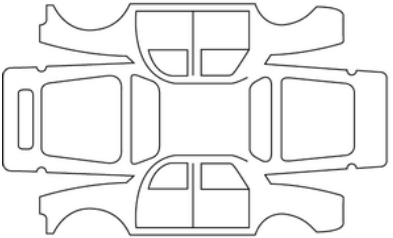
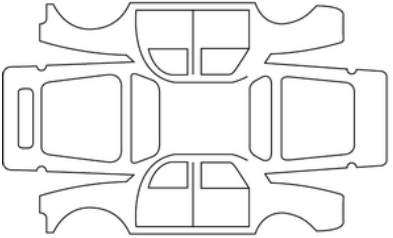
Date of repair:		Stamp
Corrosion repair operation to be carried out:		
Date of repair:		Stamp
Repair to be carried out:		

ANTICORROSION CHECK

If the continuation of the warranty is subject to repair, it is indicated below.

VIN:

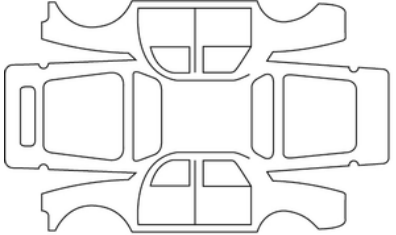
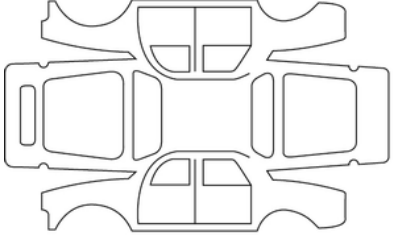
Date of repair:		Stamp
Corrosion repair operation to be carried out:		
Date of repair:		Stamp
Repair to be carried out:		

7

ANTICORROSION CHECK

If the continuation of the warranty is subject to repair, it is indicated below.

VIN:

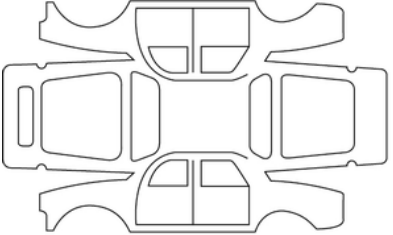
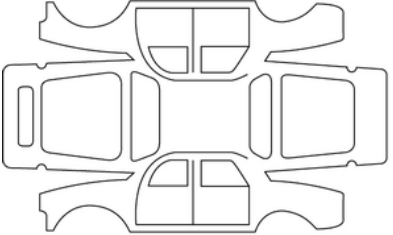
Date of repair:		Stamp
Corrosion repair operation to be carried out:		
Date of repair:		Stamp
Repair to be carried out:		

ANTICORROSION CHECK

If the continuation of the warranty is subject to repair, it is indicated below.

VIN:

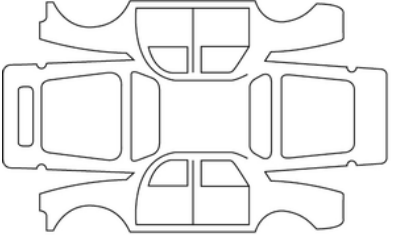
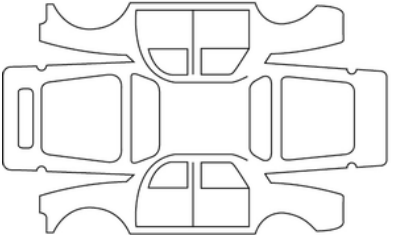
Date of repair:		Stamp
Corrosion repair operation to be carried out:		
Date of repair:		Stamp
Repair to be carried out:		

7

ALPHABETICAL INDEX

Symbols

"Hands-free" card: battery, [56](#)

360° camera, [282](#)

A

ABS, [187](#)

Accessing the vehicle, [50](#), [52](#)

Accessories, [160](#)

Accessories socket, [321](#)

Access to the engine compartment, [331](#)

Active driver assist, [232](#)

Active emergency braking in reverse gear, [245](#)

Adaptive cruise control, [232](#), [252](#)

Adjusting the front seats, [73](#), [74](#)

Adjusting your driving position, [73](#), [74](#), [78](#), [80](#), [143](#)

Airbag, [85](#), [90](#), [90](#), [102](#), [106](#), [109](#), [112](#)

Airbag : activating the front passenger airbag, [106](#), [109](#), [112](#)

Airbag : deactivating the front passenger airbag, [106](#), [109](#), [112](#)

Airbag activating the front passenger airbags, [112](#)

Airbag deactivating the front passenger airbag, [112](#)

Airbag inflatable cushion, [85](#), [90](#)

Airbags : child safety, [112](#)

Air conditioning, [306](#), [307](#), [307](#)

Air ventilation, [306](#)

Air Vents, [303](#), [306](#)

Anti-lock braking system: ABS, [187](#)

Ashtray, [321](#)

Assistance: driving aid, [252](#)

Assisted parking, [268](#), [274](#), [277](#)

Audible and visual signals, [151](#)

Autohold, [174](#)

Automatic gearbox (use), [163](#), [171](#)

Automatic gearbox breakdown recovery, [356](#)

Automatic gearbox selector lever, [163](#)

Automatic tailgate, [66](#)

AUTO mode, [143](#)

B

Batteries, [56](#)

Battery, [339](#), [357](#)

Battery: troubleshooting, [357](#)

Battery breakdown recovery, [357](#)

Blind spot: warning, [210](#)

Blind spot warning, [210](#)

Bonnet, [331](#)

Brake, [174](#)

Breakdown recovery towing, [356](#)

Bulbs replacement, [363](#)

C

Card, [50](#), [52](#)

Card: battery, [56](#)

Card: emergency key, [50](#)

Card: engine not starting in hands-free mode, [50](#)

Card: hands-free, [50](#)

Card: locking/unlocking the opening elements, [50](#)

ALPHABETICAL INDEX

Card: use, [50](#), [52](#)
Card remote control, [50](#), [50](#)
Catalytic converter, [169](#)
Central door locking, [50](#), [52](#), [62](#), [65](#)
Changing a wheel, [354](#)
Changing gears, [163](#), [178](#)
Charging cable, [37](#), [48](#)
Charging connection, [37](#)
Charging flap, [37](#)
Charging programming, [48](#)
Children, [94](#), [102](#), [106](#), [109](#), [317](#)
Child restraint, [94](#), [102](#), [106](#), [109](#)
Child restraint devices, [94](#), [102](#), [106](#), [109](#)
Child restraint system, [94](#), [102](#), [106](#), [109](#)
Child safety, [50](#), [52](#), [94](#), [94](#), [102](#), [106](#), [109](#), [317](#)
Child safety airbags, [112](#)
Child seats, [94](#), [100](#), [102](#), [106](#), [109](#)
Cigarette lighter, [321](#)
Cleaning: vehicle interior, [342](#)
Clock, [133](#), [133](#)
Closing the doors, [50](#), [52](#), [61](#), [62](#)
Configuration menu, [130](#)
Configuration menu settings, [130](#)
Control instruments, [120](#), [127](#), [133](#)
Control warning lights, [120](#), [127](#)
Coolant level, [335](#)
Courtesy light, [319](#)
Courtesy mirrors, [320](#)

Cruise control, [248](#), [252](#)
Cruise control - Speed limiter, [248](#)
Customising the vehicle settings, [130](#)

D

Daytime running lights, [50](#), [143](#)
De-icing/demisting the windscreen, [307](#)
Demisting the rear window, [307](#)
Detection of road signs, [229](#)
Detection of road signs: overspeed warning, [230](#)
Display, [127](#)
Doors, [61](#), [61](#)
Doors/luggage compartment door, [50](#), [52](#), [62](#), [65](#)
Driver assistance, [187](#), [196](#), [210](#), [216](#), [229](#), [230](#), [268](#), [274](#), [277](#), [282](#)
Driver vigilance warning, [227](#)
Driving, [160](#), [169](#), [171](#), [174](#), [183](#), [187](#), [196](#), [210](#), [216](#), [248](#), [252](#), [268](#), [274](#), [277](#), [282](#)
Driving advice, [178](#), [178](#)
Driving aids, [196](#), [210](#), [216](#), [229](#), [230](#), [252](#), [268](#), [274](#), [277](#), [282](#), [291](#), [295](#)
Driving position, [115](#)
Driving position settings, [80](#), [139](#)

E

ECO driving, [178](#), [178](#)
ECO mode, [178](#)
Electric vehicle: charging, [37](#)

ALPHABETICAL INDEX

Electric windows, [317](#)
Electronic parking brake, [171](#), [174](#)
Electronic stability program: ESC, [187](#)
Emergency brake assist, [187](#)
Emergency braking, [187](#)
Emergency key, [50](#)
Emergency spare wheel, [351](#)
Emission control advice, [177](#), [177](#)
Engine identification, [376](#)
Engine oil, [332](#), [332](#), [334](#)
Engine oil capacities, [334](#)
Engine oil dipstick, [332](#)
Engine oil level, [127](#), [332](#), [332](#), [334](#)
Engine specifications, [376](#)
Engine start/stop button, [160](#)
Environment, [176](#)
ESC: Electronic stability program, [187](#)
Excessive speed warning, [229](#), [230](#)
Exterior lighting and signals, [143](#)
Exterior lights, [361](#)
Exterior temperature, [133](#)

F

Filling with fuel, [156](#)
Filter: oil, [334](#)
Fitting a child seat, [100](#)
Fittings, [322](#)
Front seat adjustment, [74](#), [76](#)

Front seat belt pretensioners, [85](#)
Front seats, [73](#)
Front seats with electric controls, [76](#)
Front seats with manual control, [73](#)
Fuel consumption, [178](#), [178](#)
Fuel grade, [156](#)
Fuel level, [156](#)
Fuel tank cap, [156](#)
Fuel tank capacity, [156](#)
Fuel tips for reducing consumption, [178](#)
Fuses, [365](#), [365](#)

G

Gear control, [163](#)

H

Handbrake, [171](#)
Hands-free card, [52](#)
Hands-free parking, [277](#)
Hands-free telephone integrated control, [315](#)
Hazard signal, [151](#)
Headrests, [73](#), [78](#)
Heated seats, [73](#)
Heated steering wheel, [139](#)
Heated windscreen, [307](#)
Heating, air-conditioning: programming, [311](#)
Heating and air conditioning system, [303](#), [307](#)
Heating system, [303](#), [307](#), [311](#)

ALPHABETICAL INDEX

Hill descent control, [187](#)
Hill start assistance, [187](#)
Horn, [151](#)

I

Ignition switch, [171](#)
Indicators, [151](#)
Indicators: direction indicators, [151](#)
Instrument panel, [120](#), [127](#), [171](#)
Instrument panel warning lights, [120](#), [127](#), [171](#), [178](#)
Interior lighting: changing bulbs, [363](#), [363](#)
Interior trim maintenance, [342](#)
Isofix, [106](#), [109](#)

J

Jack, [351](#), [354](#)

L

Lane Centring, [232](#)
Lane departure warning, [196](#)
Lane keeping: assistance, [196](#)
Lane Keeping Assist, [196](#)
Levels, [331](#), [337](#)
Levels: coolant, [335](#)
Lifting the vehicle Changing a wheel, [354](#)
Light call, [151](#)
Lighting: instrument panel, [143](#)
Lighting: interior, [319](#), [363](#)

Lighting: see-me-home lighting, [143](#)
Lighting signals, [143](#), [151](#)
Lights: dipped beam headlights, [143](#)
Lights: direction indicator lights, [151](#)
Lights: exterior, [143](#), [151](#)
Lights: fog lights, [143](#)
Lights: hazard warning lights, [151](#)
Lights: main beam headlights, [143](#)
Lights: replacing bulbs, [361](#)
Lights: side lights, [143](#)
Lights-on reminder audible alarm, [143](#)
Locking, [80](#)
Locking/unlocking the opening elements card, [50](#)
Locking the doors, [50](#), [52](#), [61](#), [62](#), [65](#)
Luggage compartment, [50](#), [66](#)

M

Maintenance, [177](#)
Maintenance: filters, [337](#)
Maintenance: interior trims, [342](#)
Maintenance: mechanical, [332](#)
Messages on the instrument panel, [120](#), [171](#)
Methods of restraint in addition to the front seat belts, [85](#)
Multifunction screen, [210](#)
Multimedia (equipment), [315](#)
Multimedia equipment, [127](#), [143](#), [315](#)
Multimedia screen, [216](#)
Multimedia screen screens, [178](#), [196](#), [268](#), [282](#), [291](#), [307](#), [315](#)

ALPHABETICAL INDEX

Multi-Sense, [139](#), [301](#)
Multi-view camera, [282](#)

N

Navigation, [315](#)
Navigation display screen, [315](#)
Navigation screen, [315](#)
Navigation system, [315](#)

O

Oil change, [334](#)
Opening elements, [52](#), [61](#)
Opening the doors, [61](#), [62](#)
Operating faults, [85](#), [120](#), [143](#), [160](#), [169](#), [169](#), [171](#), [171](#), [187](#),
[187](#), [196](#), [196](#), [252](#), [291](#), [317](#), [317](#), [365](#), [365](#)
Operating faults: card batteries, [50](#)
Operating faults card batteries, [56](#)

P

Park Assist: assisted parking, [268](#), [274](#)
Parking: park assist, [291](#)
Parking brake, [171](#), [171](#)
Parking distance control, [268](#), [274](#)
Parking exit warning, [291](#)
Passenger safety: front passenger airbag, [112](#)
Phone, [315](#)
Power-assisted steering, [139](#), [139](#)
Pretensioners, [85](#)

Programming the heating, air conditioning, [311](#)
Puncture, [349](#), [351](#), [354](#)

R

Radio, [315](#)
Rear headrests, [78](#)
Rear parcel shelf, [66](#)
Rear seats, [78](#), [78](#)
Rear view mirrors, [139](#), [141](#), [141](#)
Regenerative braking, [167](#)
Remote control, [52](#)
Replacement and repair parts, [383](#)
Replacing windscreen wiper blades, [364](#)
Restraint devices in addition to the rear seat belts, [90](#)
Restraint in addition to the seatbelts, [85](#), [90](#), [90](#)
Reversing camera, [274](#)
Reversing radar, [268](#)
Roof bars, [330](#)
Roof bars rack, [330](#)

S

Safe distance, [252](#)
Safe distance alert, [216](#)
Safe distances, [216](#)
Safe vehicle exit, [295](#)
Seat belts, [80](#), [80](#), [85](#), [102](#), [106](#), [109](#), [342](#)
Seats front seats adjustments, [76](#)
Settings, [130](#)

ALPHABETICAL INDEX

Side protection devices, [90](#), [90](#)
Special features of petrol vehicles, [169](#)
Speed limiter, [248](#)
Spotlights, [319](#)
Starting the engine, [160](#), [160](#)
Steering column control, [315](#)
Steering column controls, [315](#)
Steering wheel adjustment, [139](#)
Stop and Start, [139](#), [156](#), [178](#)
Stop and Start function, [171](#), [178](#)
Stopping the engine, [160](#), [160](#), [171](#)
Storage compartment, [322](#)
Storage compartments, [322](#)
Sun visor, [320](#)
Switching on the vehicle ignition, [160](#)

T

Tailgate, [50](#)
Temperature regulation, [307](#)
Tool kit, [351](#)
Towing rings, [356](#)
Traction battery charging, [37](#)
Traction control, [187](#)
Traction control: ASR, [187](#)
Transporting children, [94](#), [102](#), [106](#), [109](#)
Trip computer, [120](#), [120](#)
Troubleshooting: battery, [357](#)
Tyre inflation, [183](#), [346](#), [349](#), [354](#)

Tyre inflation kit, [349](#), [351](#)
Tyre pressure, [178](#), [183](#), [346](#), [351](#), [354](#)
Tyre pressure loss warning, [183](#), [354](#)
Tyres, [178](#), [183](#), [344](#), [344](#), [346](#)

U

Unlocking the doors, [50](#), [52](#), [62](#)

V

Variable power assisted steering, [139](#)
Vehicle customisation settings, [130](#)
Vehicle settings personalisation menu, [120](#), [130](#)
Ventilation, [306](#), [307](#)

W

Warning, [151](#)
Warning lights, [210](#)
Wheelbrace, [354](#)
Wheels (safety), [344](#)
Windscreen demisting, [307](#)
Wiper, [152](#)
Wiper/washer, [364](#)
Wiper/washer replacement of blades, [364](#)
Wiper blades: replacement, [364](#)
Wireless charger induction charging, [322](#)



RENAULT S.A.S. SOCIÉTÉ PAR ACTIONS SIMPLIFIÉE AU CAPITAL DE 533 941 113 € / 122-122 BIS, AVENUE DU GENERAL LECLERC
92100 BOULOGNE-BILLANCOURT R.C.S. NANTERRE 780 129 987 — SIRET 780 129 987 03591 / renaultgroup.com

NU 1537-2 – 77 11 416 191 – 04/2024 – Edition anglaise



7711416191

