

SYMBIOZ

vehicle user manual





Welcome aboard your vehicle

This user manual contains the information required:

- for you to familiarise yourself with your vehicle, to use it to its best advantage and to fully benefit from all the functions and the technical developments it incorporates.
- to ensure that it always gives the best performance by following the simple, but comprehensive advice concerning regular maintenance.
- to enable you to deal quickly with minor faults not requiring specialist attention.

It is well worth taking a few minutes to read this manual to familiarise yourself with the information and guidelines it contains about the vehicle and its functions and new features. If certain points are still unclear, our Network technicians will be only too pleased to provide you with any additional information.

For guidance, please see the following symbols:

 and  Visible on the vehicle, they show that you should consult the manual to find detailed information and/or limits on operations in respect of equipment on your vehicle.

→ anywhere in the manual indicates a transfer to a page.



anywhere in the manual indicates a hazard, danger or a safety recommendation.

The description of the models given in this manual is based on the technical specifications at the time of writing. **The manual covers all items of equipment (both standard and optional) available for these models, but whether or not these are fitted to the vehicle depends on the version, the options selected and the country where the vehicle is sold.**

This manual may also contain information about items of equipment to be introduced later in the model year.

The diagrams in the user manual are provided as examples only.

Enjoy driving your new vehicle.

Translated from French. Copying or translation, in part or in full, is forbidden unless prior written permission has been obtained from the car manufacturer.

CONTENTS

Welcome aboard your vehicle	4	Driving	139
Exterior	4	Running in.....	139
Passenger compartment	6	Starting, stopping the engine	140
Driver's position	8	Gear control.....	143
Driving aids	10	Special features of petrol versions	148
Safety on board	12	Parking brake.....	150
Identifying a vehicle - Labels	14	Environment.....	154
The engine compartment (routine maintenance).....	16	Maintenance and antipollution advice	156
Breakdown recovery	18	Driving advice, eco-driving	157
E-Tech Full Hybrid vehicle	20	Tyre pressure loss warning.....	163
Getting to know your vehicle	22	Driver correction devices and aids	167
E-tech full hybrid	22	Additional driving aid functions	171
Card	30	Speed limiter.....	226
Doors and opening elements.....	38	Cruise control.....	230
Front seats	49	Adaptive cruise control	234
Rear seats	52	Parking aids	252
Seat belts.....	55	Emergency call	280
Additional safety devices	60	Your comfort	283
Child safety	68	MULTI-SENSE	283
Child seats	74	Air vents, heating and air conditioning.....	285
Child safety: deactivating, activating the front passenger airbag.....	92	Multimedia equipment	293
Driving position	95	Passenger compartment equipment.....	295
Trip computer.....	100	Passenger compartment storage, fittings	301
Warning lights	115	Transporting objects	304
Steering	120	Maintenance	308
Rear view mirrors.....	122	Accessing the engine, levels	308
Lighting and signals	124	Battery	316
Audible and visual signals	130	Cleaning.....	317
Wiper	131	Practical advice	321
Fuel tank.....	137	Tyres	321

CONTENTS

Breakdown recovery	332
Headlights, lights: replacing bulbs	338
Wiper blades: replacement.....	342
Fuses	344
Installation and use of accessories.....	349
Operating faults	351
Technical specifications	355
Information about the vehicle	355
Replacement parts and repairs	361
Service sheets	362
Anticorrosion check	368

EXTERIOR

1

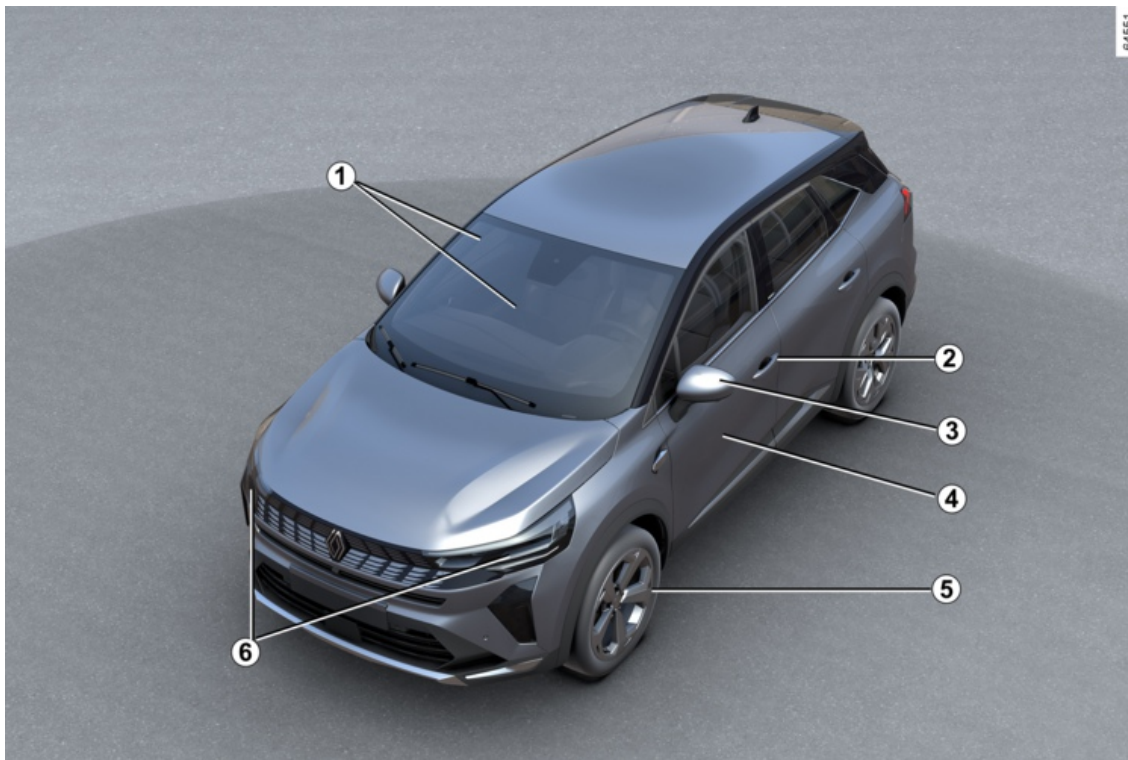

EXTERIOR

1. Electric windows → 295
Screen wiper, washer → 131
Demisting → 285

2. → 30 card
Locking, unlocking the doors → 39

3. Rear view mirrors → 122

4. Bodywork maintenance → 317

5. Tyres → 321

6. Lights: operation → 124
Lights: replacement → 338



Filling with fuel → 137

PASSENGER COMPARTMENT

1

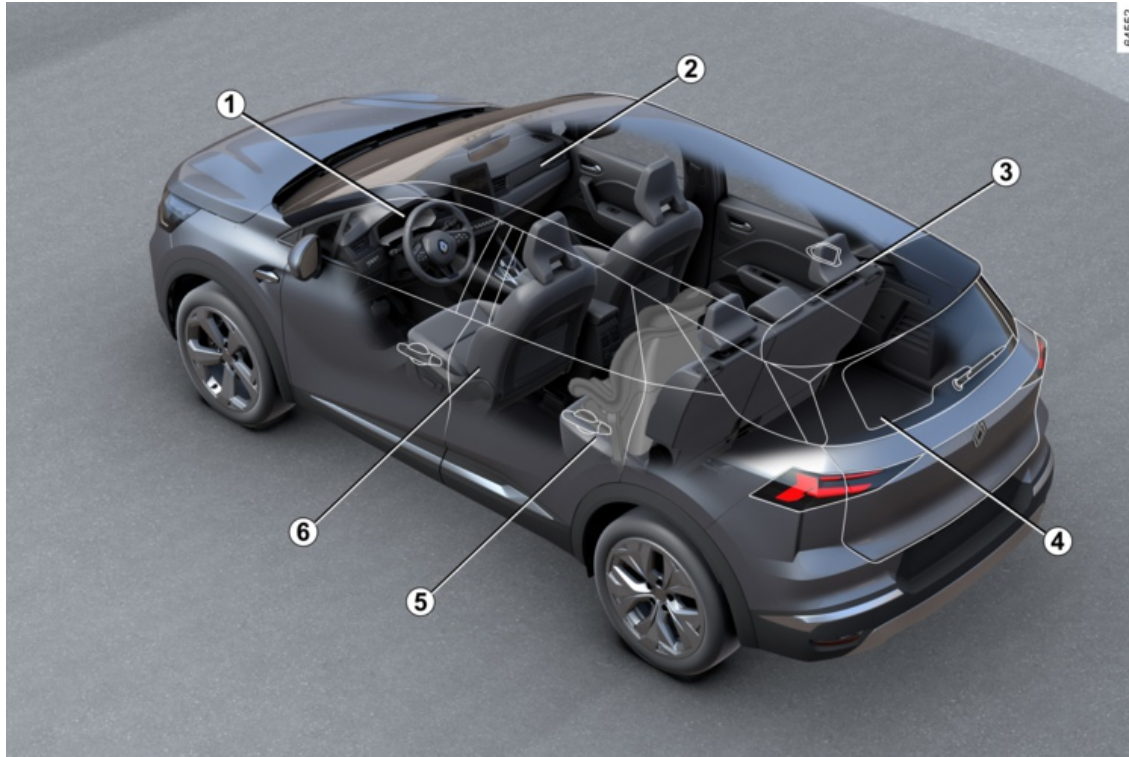

6 - Welcome aboard your vehicle

PASSENGER COMPARTMENT

1. Adjusting your driving position → **49**
2. Passenger compartment storage/fit-tings → **301**
3. Rear headrests → **52**
Rear bench seat → **53**
4. Transporting objects → **305**
5. Child safety → **68**
6. Front headrests → **49**
Front seats → **49**

DRIVER'S POSITION

1

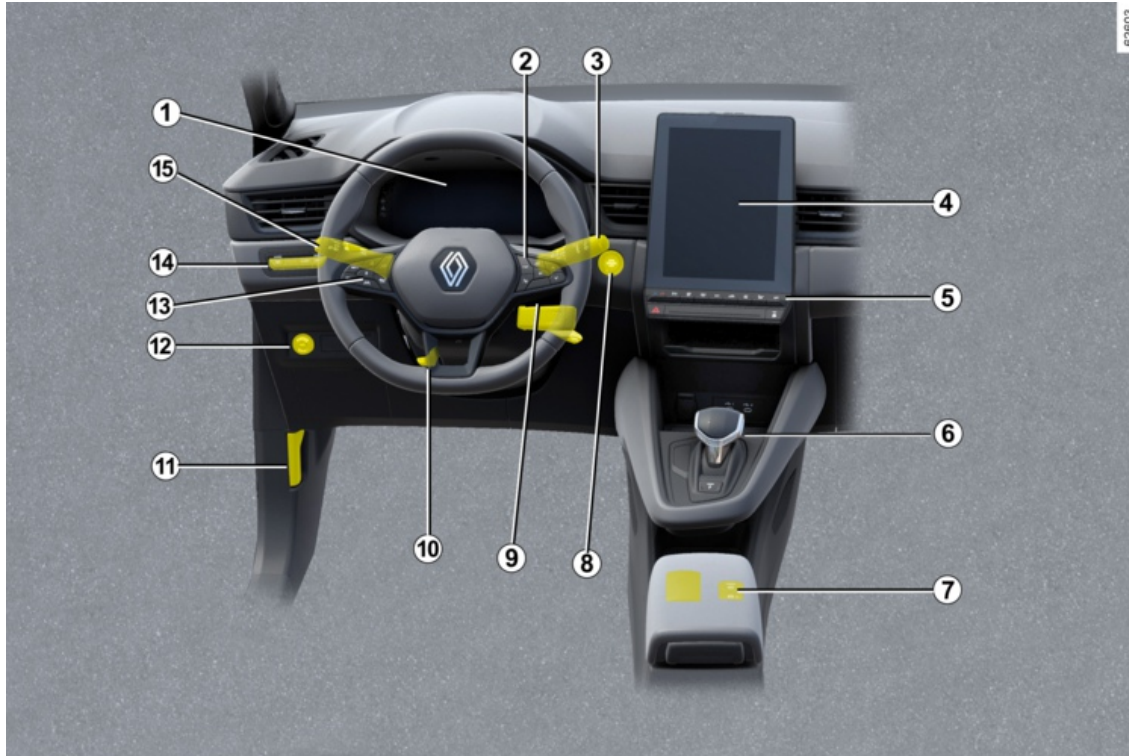

026003

DRIVER'S POSITION

1. Instrument panel → 115
 2. Trip computer controls → 100
 3. Window wiper(s)/washer(s) control → 131
 4. Multimedia screen → 293
 5. Heated seat(s) → 49
- Heating system/air conditioning → 285
6. Gear lever → 143
 7. Electronic parking brake → 150
 8. Engine start/stop button → 140
 9. Multimedia control → 293
 10. Steering wheel adjustment → 120
 11. Bonnet release → 308
 - 12.
- Motorised tailgate opening closing control → 43
13. Speed limiter → 226
- Cruise control → 230
→ 234 adaptive cruise control
14. My Safety → 171
 15. Exterior lighting → 124

DRIVING AIDS

1

62354

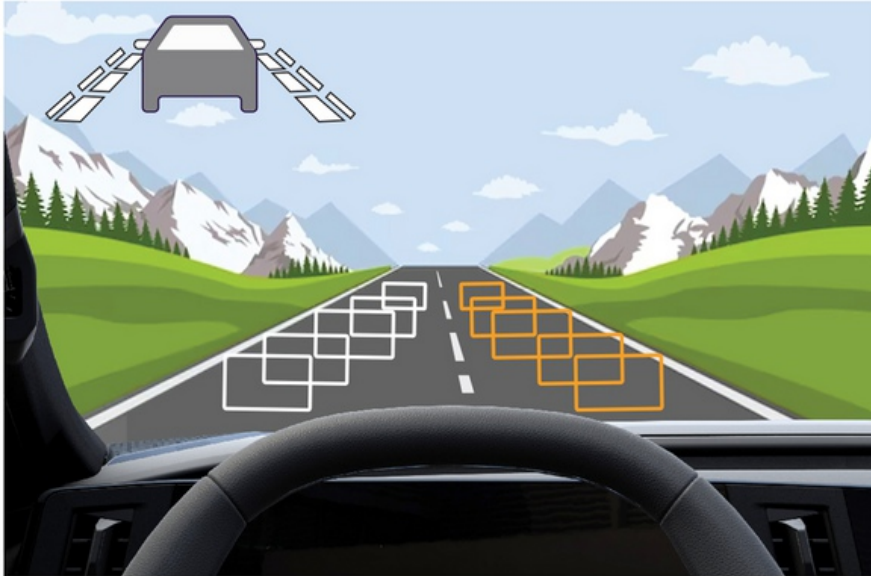

DRIVING AIDS

- Driver correction devices and aids
→ **167**
- Lane departure prevention → **172**
- Emergency lane departure prevention → **179**
- Active emergency braking → **195**
- Blind spot warning → **186**
- Parking exit warning → **272**
- Tyre pressure loss warning → **163**
- Active driver assist → **209**
- Speed limiter → **226**
- Cruise control → **230**
- Stop and Go adaptive cruise control
→ **234**
- Road sign detection → **204**
- Park Assist → **252**
- Reversing camera → **258**
- 360° camera → **266**
- Safe vehicle exit → **277**
- Safe distance warning → **192**
- Driver vigilance warning → **202**

SAFETY ON BOARD

1

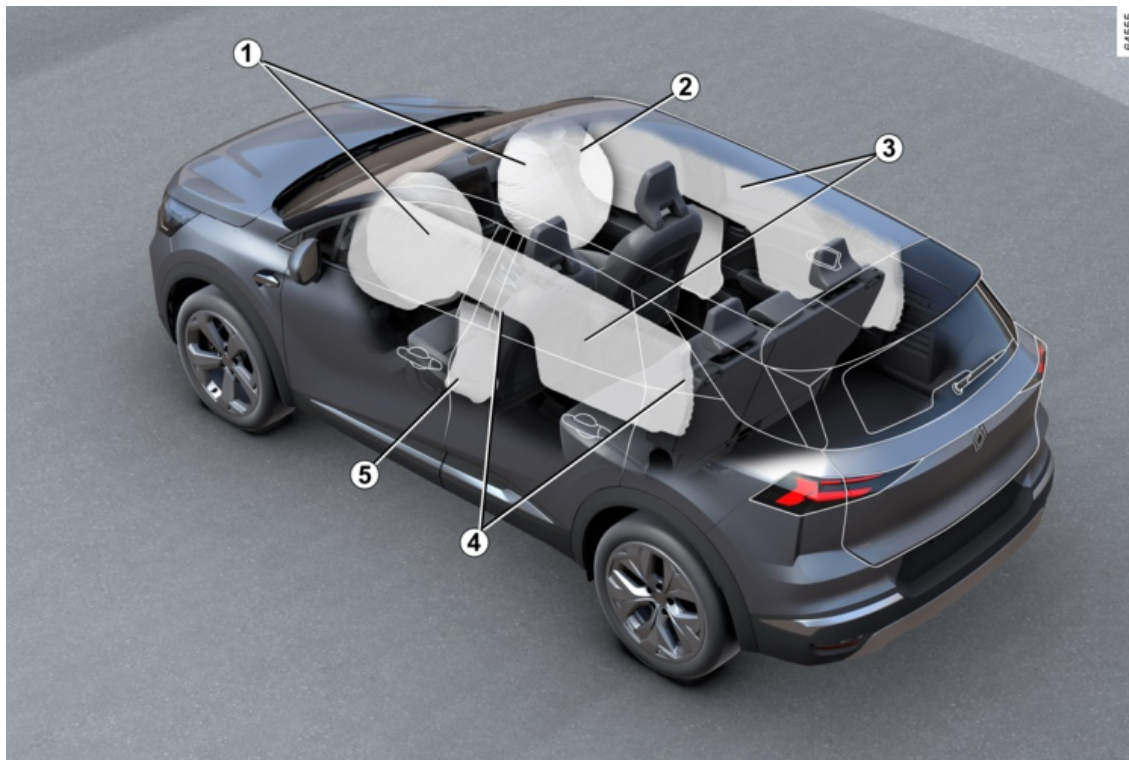

SAFETY ON BOARD

1. Front airbags → **60**
2. Deactivating the passenger's front airbag → **92**
3. Curtain air bags → **65**
4. Seat belts → **55**
5. Side air bags → **65**

IDENTIFYING A VEHICLE - LABELS

1

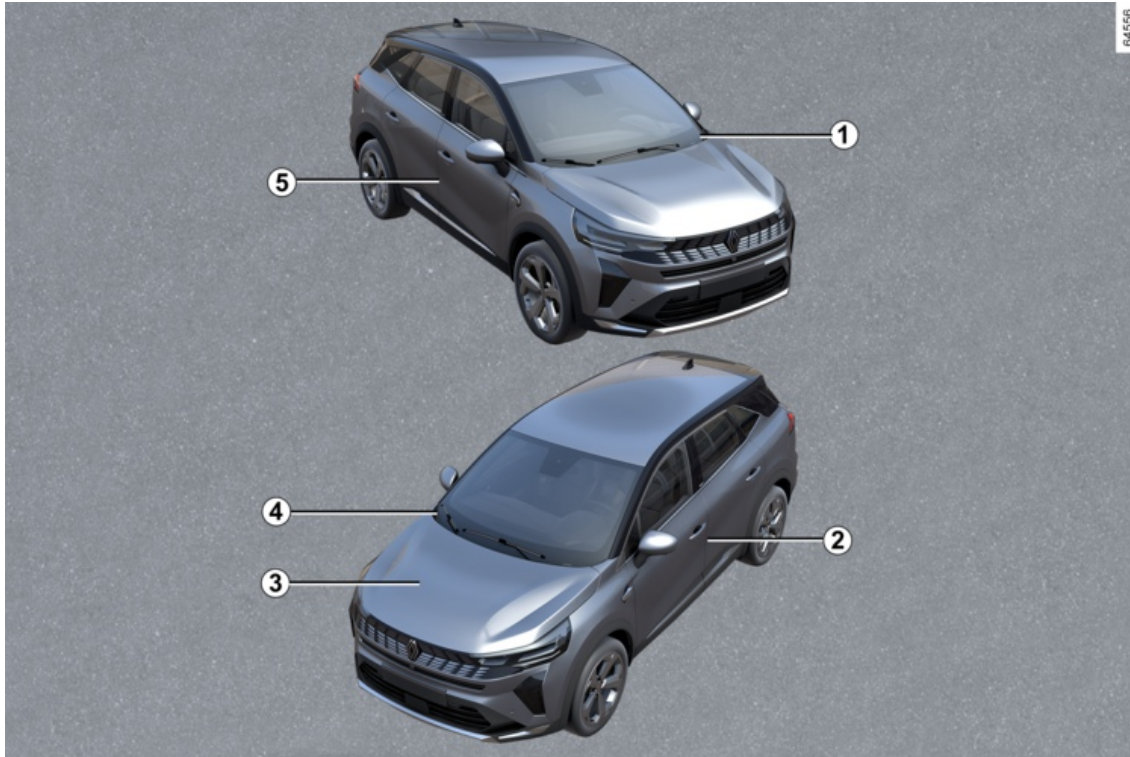

IDENTIFYING A VEHICLE - LABELS

1. Vehicle identification number reminder → **355**
2. Tyre pressure labels → **163** → **323**
3. Engine identification → **356**
4. Technical information for the emergency services → **355**
5. Vehicle identification plate → **355**

THE ENGINE COMPARTMENT (ROUTINE MAINTENANCE)

1

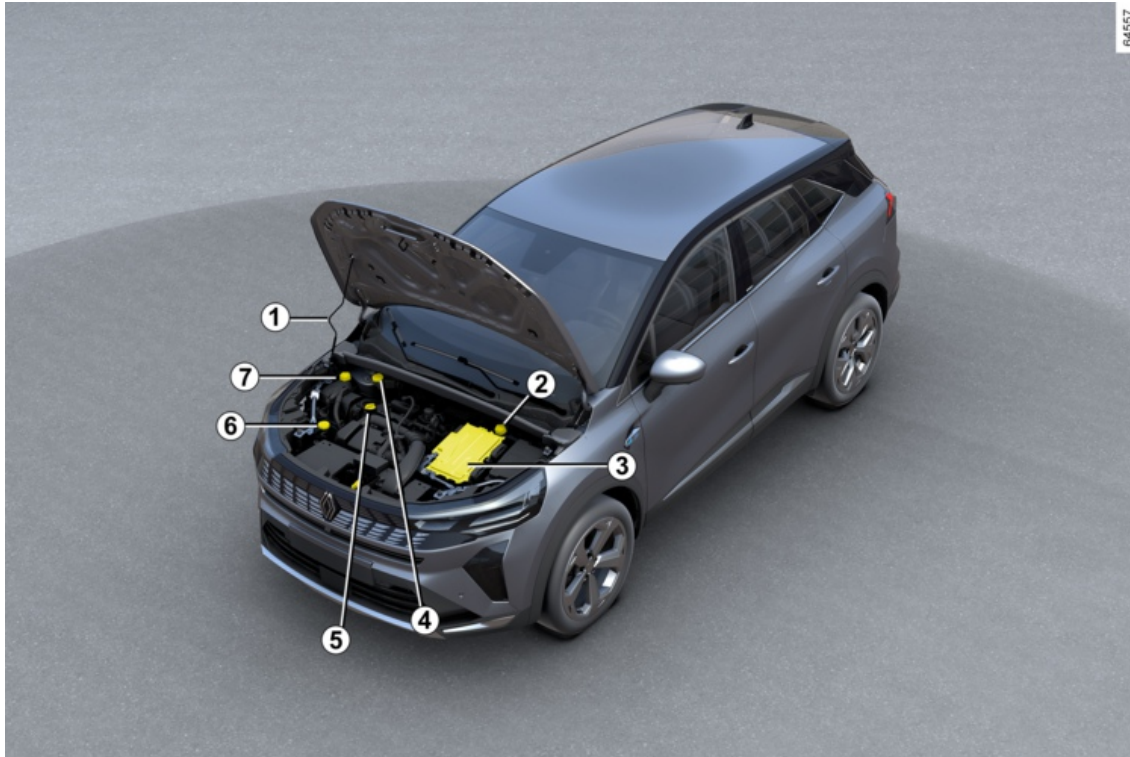

THE ENGINE COMPARTMENT (ROUTINE MAINTENANCE)

1. Opening the bonnet → 308
2. Electric traction system coolant
→ 313
3. Battery → 316
4. Brake fluid → 314
5. Engine oil filler cap
Engine oil dipstick → 309
6. Screen washer fluid → 315
7. Combustion engine coolant → 312

BREAKDOWN RECOVERY

1

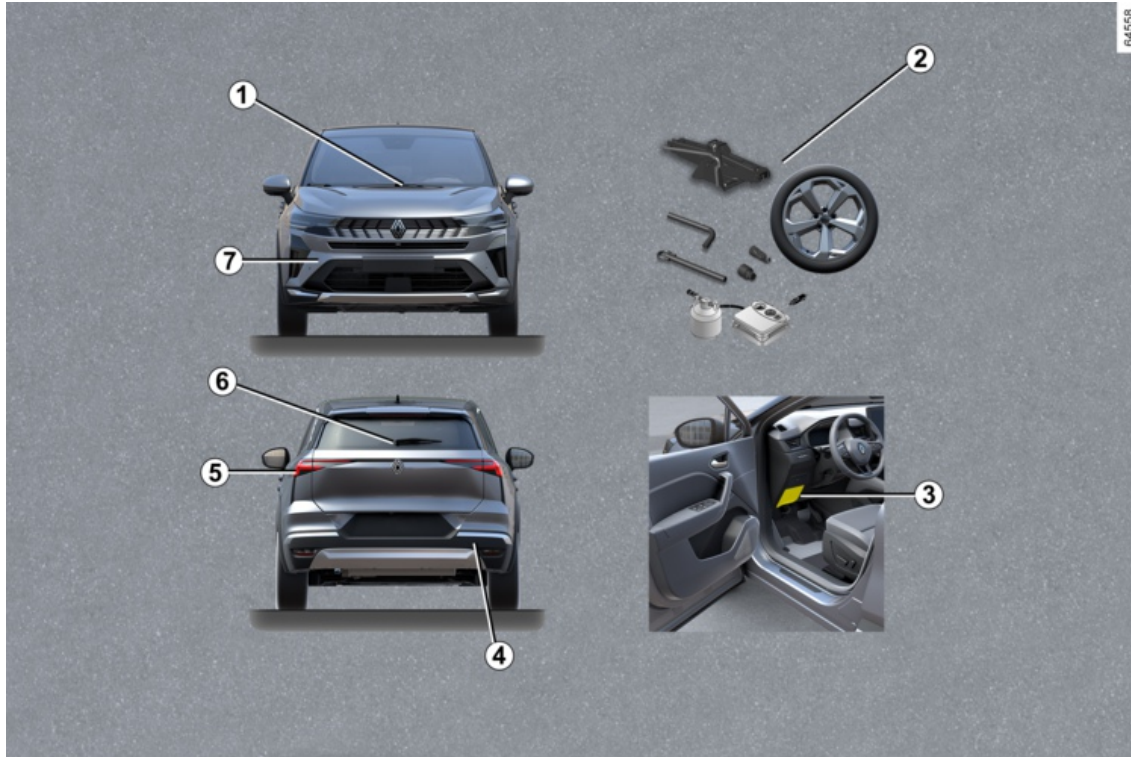

BREAKDOWN RECOVERY

1. Replacing windscreen wiper blade(s) → **342**

2. Puncture → **328**

Tools → **327**

Emergency spare wheel → **328**

Changing a wheel → **330**

3. Fuses → **344**

4. Rear towing point → **332**

5. Replacement of the direction indicator lights → **338**

6 Replacing the rear screen wiper blade → **342**

7. Front towing point → **332**

E-TECH FULL HYBRID VEHICLE

1

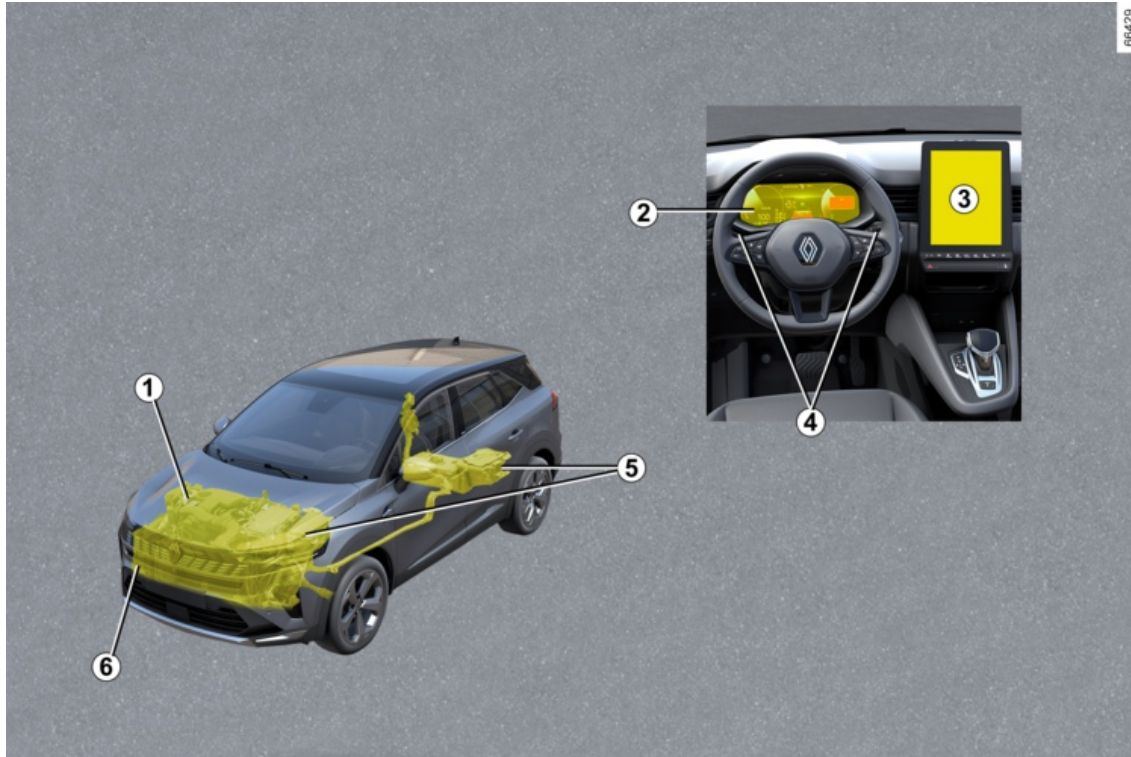

E-TECH FULL HYBRID VEHICLE

1. Coolant → 313
2. Warning lights → 115
Displays and indicators → 107
"E-save" mode → 28
3. Multimedia screen
4. Regenerative braking change paddle
5. Battery → 316
- 6 Towing breakdown recovery → 332

E-TECH FULL HYBRID

Introduction

2

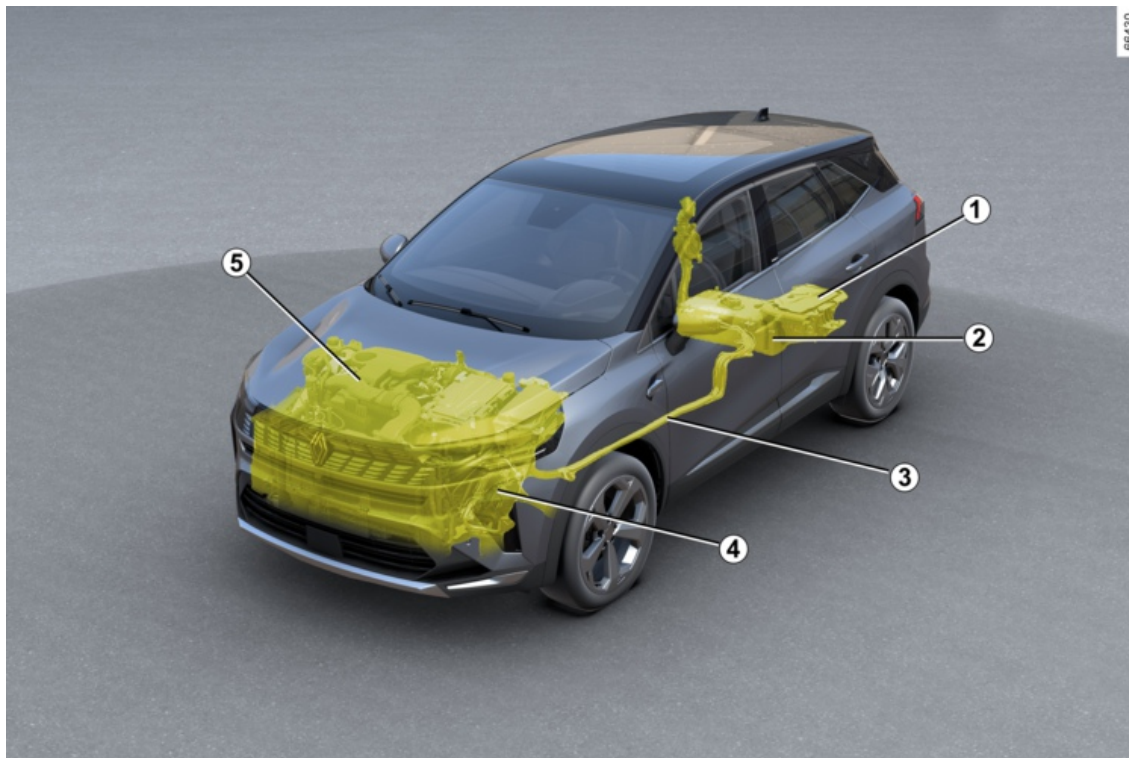

E-TECH FULL HYBRID

- 1 Secondary "12 V" battery
- 2 "230 volt" traction battery
- 3 Orange electrical power cables
- 4 Electric motor
- 5 Combustion engine

The hybrid vehicle system uses an electric motor to improve the performance of the combustion engine (acceleration, starting etc.).

The vehicle has more acceleration torque available while consuming less fuel.

The vehicle may also move in all-electric operating mode without any assistance from the combustion engine. The vehicle uses energy stored in the "230 V" traction battery.

Batteries

The hybrid vehicle is equipped with two types of battery:

- a "230 V" traction battery;
- a secondary "12 V" battery.

"230 volt" traction battery

This battery, located underneath the rear floor, stores the energy required for the electric motor to operate correctly.

As with any battery, it discharges when it is used. The traction battery is charged:

- during the vehicle deceleration phases;
- when the combustion engine starts automatically in order to act as a generator.

Your vehicle range in electric operating mode depends on the charge level of the traction battery, and also on your driving style and the components consuming energy (air conditioning, heating system etc.).

The vehicle's air conditioning system is used to cool the traction battery. To preserve the lifetime of your traction battery, have your air conditioning system checked by a qualified professional. Especially if you notice a reduction in air conditioning performance.

In the event of traction battery discharge, the combustion engine alone moves the vehicle until the traction battery is sufficiently recharged.

If your vehicle is parked for a long time, start the engine at regular intervals (about once a month) and check

that the  warning light is displayed in blue on the instrument panel. If this happens, the battery needs to be recharged: leave the engine on until

the warning light is displayed in blue (➔ 107).

Failure to do so may result in damage to the traction battery and make it impossible to start the vehicle.

Secondary "12 V" battery

The secondary "12 V" battery, located in the luggage compartment, supplies the energy required to open/close the vehicle and to operate the equipment.

Note: the secondary "12 Volts" battery does not participate when the engine is started. This is ensured by the hybrid system.

E-TECH FULL HYBRID

2



The electrical system of the hybrid vehicle uses direct voltage of approximately 230 V.

This system can get hot during and after switching off the ignition. Observe the warning messages on the labels in the vehicle.

All operations on or modifications to the "230 V" electrical system (components, cables, connectors, traction battery) are strictly prohibited due to the risks they present to your safety. Call an approved dealer.

The risk of serious burns or electric shocks can lead to death.

"230 V" electrical circuit

A

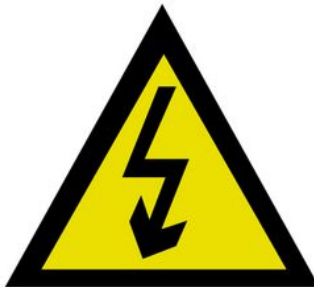

The **A** symbol identifies the electrical elements in your vehicle which may present safety risks.

61607



65968

The "230 V" electrical circuit can be recognised by orange cables **6** and

parts bearing the  symbol.

Noise

The hybrid vehicles are particularly quiet in electric operating mode.

You will not yet necessarily be used to it, and neither will other road users. It is difficult for them to hear your vehicle when it is moving.

As the electric motor is silent, you will hear other noises that may seem unusual (aerodynamic noises, tyres, etc.) as well as noises due to the operation of the hybrid system (e.g. cooling of the traction battery).

E-TECH FULL HYBRID



Your hybrid vehicle is very quiet. When getting out of the vehicle, always check that the gear selector is in P position, apply the parking brake and switch off the ignition.

RISK OF SERIOUS INJURY.

Pedestrian horn

The pedestrian horn enables you to warn others of your presence – especially pedestrians and cyclists.

In electric operating mode, the system is activated automatically.

The sound is emitted when the vehicle speed is between approximately 1 and 19 mph (1 and 30 km/h).

For further information on the pedestrian horn, refer to the multimedia instructions.

In the event of a fault with the pedestrian horn, the  warning light is displayed on the instrument panel, accompanied by the "Exterior sound fault" message.

Consult an approved dealer.

Operation

The hybrid system selects the combustion engine and/or the electric engine according to the driving style (smooth, sporty, etc.), the traffic conditions and driving mode selected → **283**.

Bad weather, flooded roads:



Do not drive through floods if the depth of water is above the lower edge of the wheel rims.

Energy flow

The display varies according to instrument panel **B** and **C**.

Instrument panel **B**

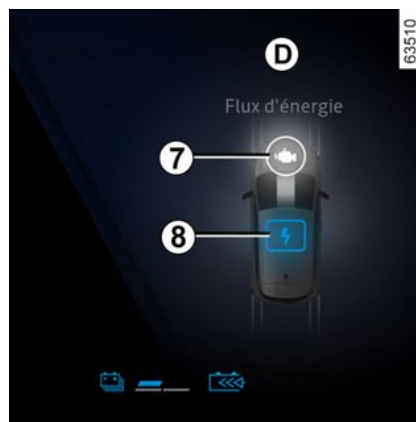

2

E-TECH FULL HYBRID

Depending on the driving mode selected, the various energy flows **D** are shown on the instrument panel.

These are energy flows between:

- **7**: the combustion engine;
- **8**: the electrical assembly (traction battery and electric motor).

The colour of flows varies:

- white: energy produced by the combustion engine.
- blue: electrical energy;



Regenerative braking level warning light **E**

When you lift your foot off the accelerator pedal or when you press on the brake pedal, the electric motor and/or the regenerative braking system

convert(s) the energy produced by the vehicle deceleration into electric energy.

This is used to brake the vehicle and recharge the traction battery.

Instrument panel **C**

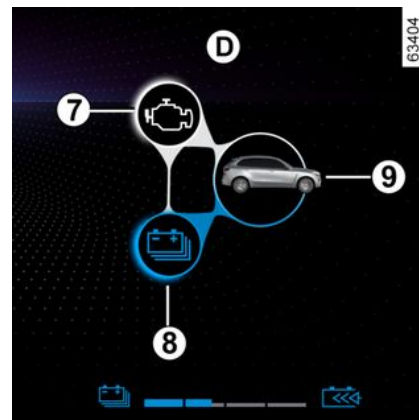

Depending on the driving mode selected, the indicator light **D** represents the energy flows between:

- the combustion engine **7**;
- the electrical assembly (traction battery and electric motor) **8**;
- the vehicle **9**.

E-TECH FULL HYBRID

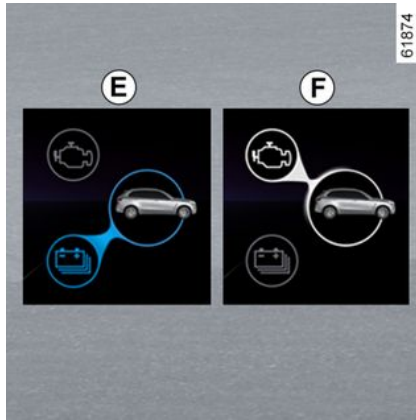

The colour of flows varies:

- blue: electrical energy;
- white: energy produced by the combustion engine.

Flow E "Electric traction"

The electrical assembly is used to move the vehicle.

Flow F "Combustion engine traction"

The combustion engine is used to move the vehicle.

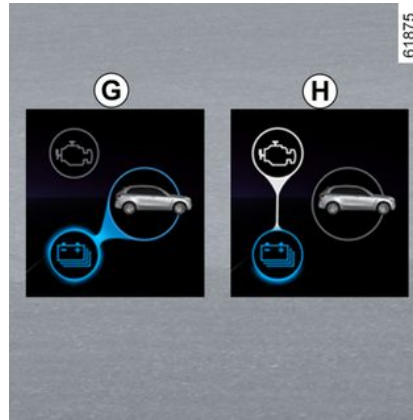

Flow G "Energy recovery"

When you lift your foot off the accelerator pedal or when you press on the brake pedal, the electric motor and/or the regenerative braking system convert the energy produced by the vehicle deceleration into electric energy.

This is used to brake the vehicle and recharge the traction battery.

Flow H "Energy production"

The combustion engine recharges the traction battery.

Note: a combination of different flows is possible (e.g. combining flow E and flow F means that the combustion engine and the electric motor are being used to move the vehicle).



Special case

When the traction battery reaches a maximum charge level, the engine brake is temporarily reduced. Please adapt your driving style appropriately.



The engine brake should under no circumstances be used as a substitute for the brake pedal.

All-electric driving mode



10

E-TECH FULL HYBRID

2

The warning light **10** **EV** displayed on the instrument panel informs you that the hybrid system is using only the electrical assembly to power the vehicle movement.

Note: when the traction battery level is low, the vehicle automatically switches to hybrid mode and the combustion

engine starts: the **10** **EV** warning light disappears from the instrument panel to confirm this.

Maintaining the traction battery charge level "E-save"

This mode enables you to maintain a sufficient charge level in the traction battery in anticipation of driving on a mountain road or a long motorway slope.

Activation, deactivation of the "E-save" function



With the engine running, press switch **11**.

The warning light **11** illuminates.

Press the switch **11** again to deactivate this mode.

The indicator light of the switch **11** goes out.

Important recommendations



Please read these instructions carefully. Failure to follow these instructions may lead to **a risk of fire, serious injury or electric shocks which could result in death.**

In the event of an accident or impact

In the event of an accident or an impact to the underside of the vehicle (e.g. striking a post, raised kerb or other street furniture) the electric circuit or the traction battery may be damaged.

Have the vehicle checked by an authorised dealer.

Never touch the "230 V" components or orange cables which are exposed and visible inside or outside the vehicle.

In the event of serious damage to the traction battery, leaks may occur:

- never touch liquids (fluids, etc.), coming from the traction battery;
- in the event of contact with the body, wash the affected area with plenty of water and consult a doctor as soon as possible.

In the event of fire

In the event of a fire, leave the vehicle immediately and evacuate it, then contact the emergency services, informing them that this is a hybrid vehicle.

If you have to intervene, only use ABC or BC extinguishing agents that are suitable for extinguishing fires on electrical systems. Do not use water or other extinguishing agents.

In the event of damage to the electrical circuit, please call an authorised dealer.

All towing operations

Refer to the paragraph entitled "Towing, breakdown recovery" → 332.

Washing the vehicle

Never wash the engine compartment and "230 V" traction battery using a high-pressure washer.

This risks damaging the electric circuit.

Risk of electric shock and a risk to life.

CARD

General information

2

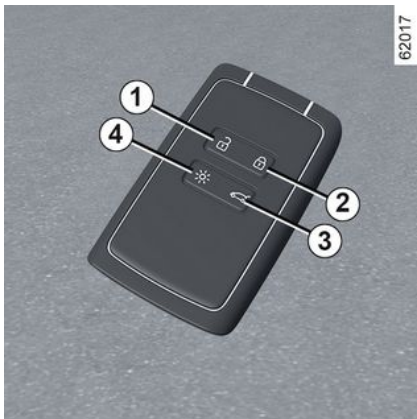

1. Unlocking the doors and luggage compartment.
2. Locks all the opening elements.
3. Locking/unlocking the boot only.
4. Switching on the lighting remotely.

The card is used for:

- locking/unlocking the opening elements (doors, luggage compartment and fuel filler flap) → 39;
- switching on the vehicle lighting remotely;
- automatically closing the electric windows remotely → 295;
- starting the engine → 140.



If the battery is flat, you can still lock/unlock and start your vehicle → 39, → 140.

Range

Make sure that the correct battery type is being used, and that the battery is in good condition and inserted correctly. Its service life is approximately two years: it should be replaced when the "Keycard Battery Low" message appears on the instrument panel → 35.

card operating range

This varies according to the surroundings: take care not to accidentally lock or unlock the vehicle by inadvertently pressing the buttons on the card.

Note: if a door or the luggage compartment door is open or not properly shut, the vehicle will not be locked. A beep sounds and the hazard warning lights and side repeaters do not flash.

"Remote lighting" function

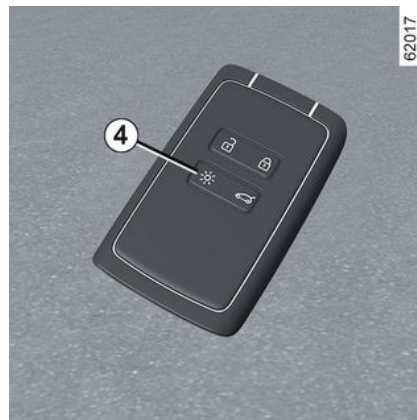

Press button 4 to switch on the dipped beam headlights and the exterior lighting for approximately 20 seconds. This can be used, for example, to identify the vehicle from a distance when parked in a car park.

Press and hold button 4 for approximately two seconds to switch on the exterior lighting and emit a sound.

Note: press button 4 again to switch off the lighting.

CARD



Recommendations

Avoid leaving the card in hot, cold or humid areas. Do not keep the card in a place where it could be bent or damaged accidentally, such as in your back pocket.



Replacement: need for an additional card

If you lose your card or require another, you can obtain one from an approved dealer. If a card is replaced, it will be necessary to take the vehicle **and all its cards** to an approved Dealer to initialise the system. You may use up to four cards per vehicle.

Interference

Interference by factors in the immediate vicinity (external installations or the use of equipment operating on the same frequency as the card) may disrupt its operation.



Driver's responsibility when parking or stopping the vehicle

Never leave an animal, child or adult who is not self-sufficient alone in your vehicle, even for a short time.

They may pose a risk to themselves or to others by starting the engine, activating equipment such as the electric windows or locking the doors.

Also, in hot and/or sunny weather, please remember that the temperature inside the passenger compartment increases very quickly.

RISK OF DEATH OR SERIOUS INJURY.

Fitting a strap 7

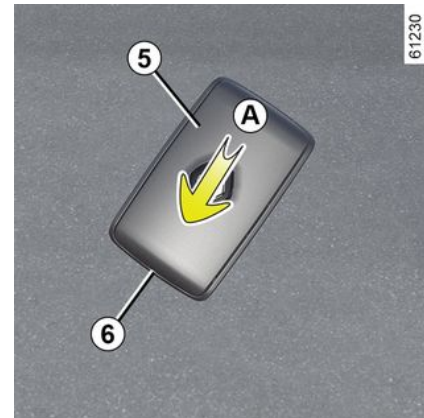

Slide the rear casing **5** downwards while pressing on area **A**.

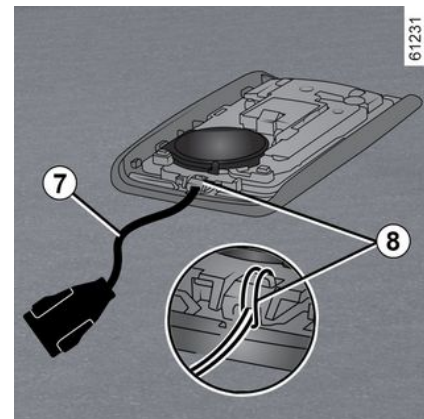

CARD

Insert the hand strap into the component **8** and pass the end of the strap through the buckle.

Position the strap at the opening **6** and close the casing.

Note: check that the diameter of the hand strap cord **7** fits the opening **6**.

Use

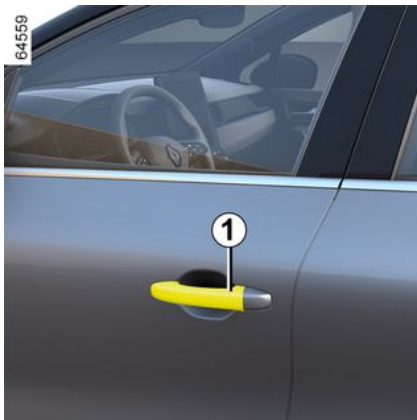

Depending on the vehicle, there are two ways to unlock/lock the vehicle:

- in "hands-free" mode, when approaching and moving away from the vehicle;
- using the card in remote control mode.



Do not store the card anywhere it may come into contact with other electronic equipment (computer, phone etc.) as this could hinder its operation.

Deactivating/activating the "hands-free mode"

Depending on the vehicle, you can deactivate/activate unlocking when approaching and locking when moving away from the vehicle.

You can also deactivate/activate the sound signal that is emitted upon locking when moving away from the vehicle → 112.



Never leave your vehicle with the card inside.



Driver's responsibility when parking or stopping the vehicle

Never leave an animal, child or adult who is not self-sufficient alone in your vehicle, even for a short time.

They may pose a risk to themselves or to others by starting the engine, activating equipment such as the electric windows or locking the doors.

Also, in hot and/or sunny weather, please remember that the temperature inside the passenger compartment increases very quickly.

RISK OF DEATH OR SERIOUS INJURY.

CARD

"Hands-free" unlocking when approaching the vehicle



64560

With the card in the access zone **2**, the vehicle will be unlocked.

The hazard lights and side repeaters **flash once** to indicate that the doors have unlocked and, on some vehicles, the door mirrors fold out automatically.

"Hands-free" locking when moving away from the vehicle



64561

With the card on you and the doors and luggage compartment door closed, move away from the vehicle: it will be locked automatically as soon as you leave the access zone **3**. The hazard lights **flash twice then stay on** for about four seconds, a beep sounds to indicate that the doors have locked and, on some vehicles, the door mirrors fold in automatically.

Note: the distance at which the vehicle locks depends on the surroundings.

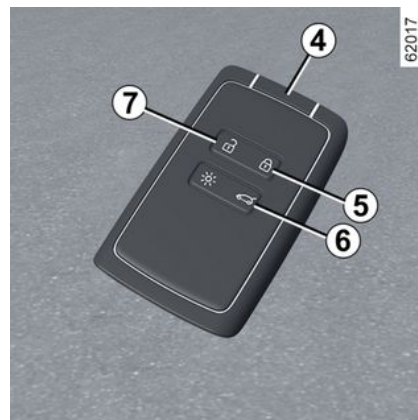

2

If the card **4** has been within the detection zone **3** for approximately 15 minutes, remote locking is deactivated. To lock the vehicle, press the button **5** on the card **4**.

The vehicle cannot be remotely locked if the card is within the zone **3**.

Special features of the unlocking system

Under certain circumstances, unlocking when approaching the vehicle is deactivated:

- if the vehicle has not been used for eight days;
- if the card remains close to vehicle zone **2** during approximately five min-

CARD

utes **after the vehicle has been locked**;

– after several passes in the vicinity of zone **2** **without the doors having been unlocked**.

Use the card as a remote control to unlock the vehicle and reactivate the hands-free mode.

Special features relating to "hands-free" locking

After locking in "hands-free" mode, you have to wait approximately three seconds to be able to unlock the vehicle again. During these three seconds, the door handles can be tried to make sure that the vehicle is locked properly.

Note: if a door or the luggage compartment door is open or not properly shut, the vehicle will not be locked. A beep sounds and the hazard warning lights and side repeaters do not flash.

Using the card as a remote control

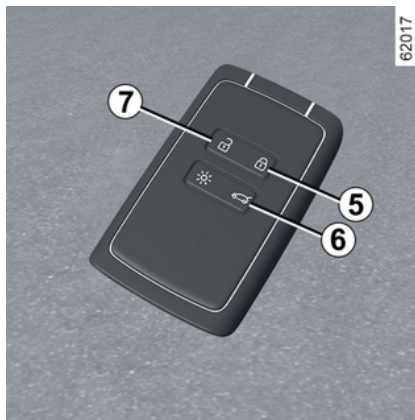

Unlocking with the card

Press the button **7**.

Unlocking is indicated by **one flash** of the hazard warning lights and the indicator lights.



The card buttons are deactivated when the engine is running.

Locking using the card

With the doors and luggage compartment door closed, press button **5**: the vehicle will be locked.

The hazard warning lights **flash twice** to indicate that the vehicle is locked and, depending on the vehicle, the door mirrors fold in automatically.

Depending on the vehicle, press button **5** twice to lock the vehicle. Press and hold button **5** to close the front and rear windows.

Note:

– the maximum distance at which the vehicle locks depends on the surroundings;
– if a door or the boot is open or not properly shut, locking is not carried out. A beep sounds but the hazard warning lights and side repeaters do not flash.



CARD

After a door is opened and closed **while the engine is running**, if the card is no longer in zone **3**, the "Card not detected" message warns you that the card is no longer in the vehicle. This will, for example, prevent you from driving away after dropping off a passenger who has kept the card on them.

The warning disappears when the card is detected again.

Locking/unlocking the boot only

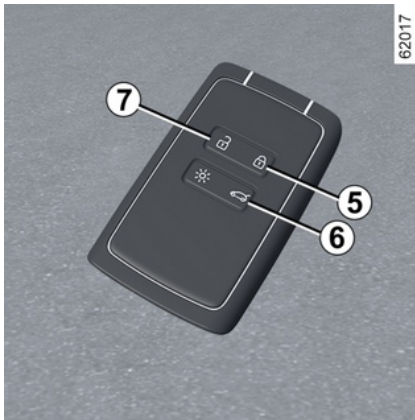

Press button **6** to lock/unlock the luggage compartment only.

Deadlocking

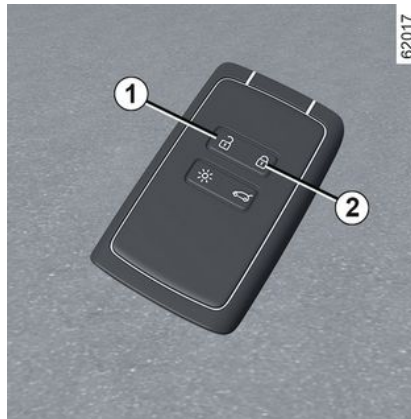

If the vehicle is equipped with a deadlocking function, this allows you to lock the opening elements and to prevent the doors from being unlocked using the interior handles (for example, by breaking the window and then trying to open the door from the inside).



Never use deadlocking if someone is still inside the vehicle.

To activate deadlocking

Press button **2** twice in quick succession.

Locking is confirmed by **two slow flashes and three quick flashes** of the hazard warning lights and side repeaters.

Depending on the vehicle, the door mirrors may fold in automatically when the vehicle is locked → **122**.

To deactivate deadlocking

Press button **1** once.

The hazard warning lights **flash once** to indicate that the doors have been unlocked.

"Hands-free" card: battery

Replacing the battery

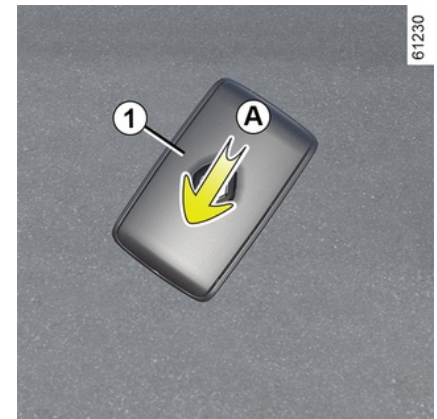

CARD

2





When the "Card battery low" message appears on the instrument panel, replace the battery in the card:

- slide the rear casing **1** downwards while pressing on area **A**;
- remove the battery cover **2**;
- remove the battery by pressing on one side and lifting the other;
- replace it according to the direction and template indicated inside the cover.

To refit, proceed in the reverse order then press one of the buttons on the card four times while you are near the vehicle: the next time the vehicle is started, the message will disappear. Check that the cover is clipped shut.

Note: when replacing the battery, do not touch the electronic circuit or contacts on the card.

 The batteries are available from approved Dealers, and their service life approximately two years. Check that there is no dye on the battery: risk of an incorrect electrical contact.

 If they need to be replaced, be sure to use the same or equivalent type of battery (consult an Approved Dealer).

 When replacing:
– make sure that the batteries are correctly inserted.

Risk of explosion.

- if the flap does not close correctly, do not use the card and keep out of reach of children.

Operating faults

If the battery is too weak to ensure correct operation, you will still be able to start and lock/unlock the vehicle → **39**.



 Do not throw away your used batteries as rubbish. Take them to an approved dealer or consult your local authority for information on appropriate recycling facilities.

61496

CARD



Precautions relating to batteries:

- keep batteries (new or used) out of reach of children;
- do not swallow batteries;

Risk of chemical burns which may lead to death.

- if ingested or inserted into any part of the body, consult a doctor as soon as possible.

DOORS AND OPENING ELEMENTS

Opening and closing the doors

2

Opening from the outside

Front doors



With the doors unlocked or the card on you, hold the handle **1** and pull it towards you.

Rear doors

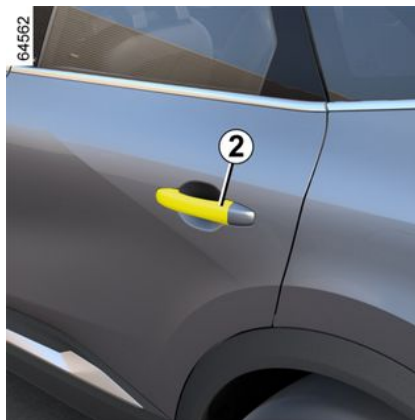

With the doors unlocked or the card on you, hold the handle **2** and pull it towards you.

Opening from the inside

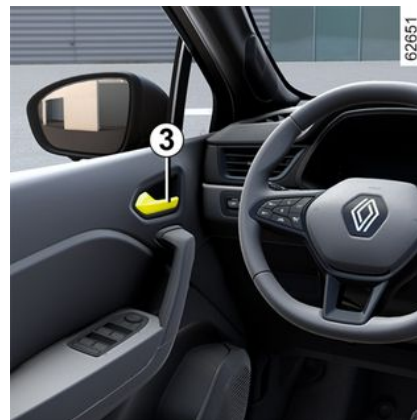

Pull the handle **3**.

Depending on the vehicle, it may be necessary to pull the handle **3** twice: the first time to unlock the door, the second time to open it.



As a safety precaution, the doors should only be opened/closed when the vehicle is stationary.

Lights-on reminder audible alarm

If you have switched off the ignition and left the lights switched on, a warn-

DOORS AND OPENING ELEMENTS

ing buzzer will sound when a door is opened.

Door or luggage compartment lid open buzzer



62850

With the vehicle stationary and the ignition switched on, the graphic 4 on the instrument panel indicates the opening element(s) (doors, luggage compartment) that are open or incorrectly closed.

Once the vehicle reaches a speed of approximately 6 mph (10 km/h), a warning light indicates if the door(s) or luggage compartment are open or not properly closed and the "Luggage compartment open" or "Door open" message and a beep will sound for

around 40 seconds until the door or luggage compartment is closed.

Child safety

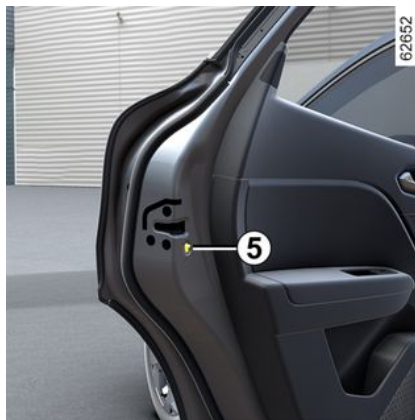

62852

To prevent the rear doors being opened from the inside, move the lever 5 and check from the inside that the doors are securely locked.



Driver's responsibility when parking or stopping the vehicle

Never leave an animal, child or adult who is not self-sufficient alone in your vehicle, even for a short time.

They may pose a risk to themselves or to others by starting the engine, activating equipment such as the electric windows or by locking the doors.

Also, in hot and/or sunny weather, please remember that the temperature inside the passenger compartment increases very quickly.

RISK OF DEATH OR SERIOUS INJURY.

Locking, unlocking the opening elements and doors

If the card does not work:

In certain cases, the card may not work:

- when the card battery is flat or the vehicle battery is discharged, etc.;
- use of appliances operating on the same frequency as the card (mobile phone, etc.);

DOORS AND OPENING ELEMENTS

– the vehicle is located in a high electromagnetic radiation zone.

It is then possible:

- to use the hands-free card's built-in emergency key to unlock the driver's door;
- to use the interior door locking/unlocking control;

The card's built-in key

Access with key 2

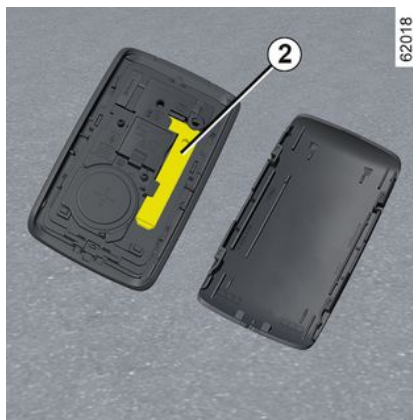
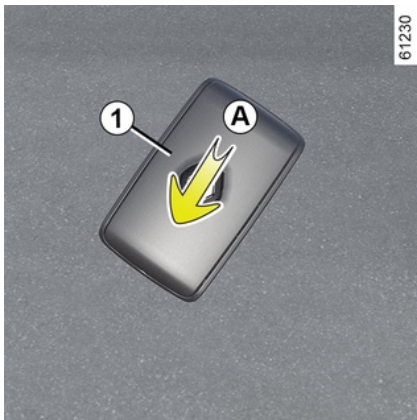

The built-in key **2** can be used to lock or unlock the driver's door when the card is not working.

Slide the rear casing **1** downwards while pressing on area **A**.

Using the key integrated in the card

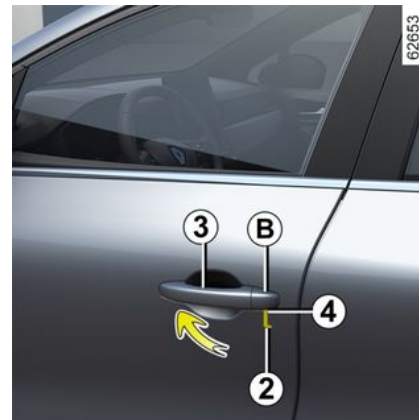

- Pull the handle **3**;
- press downwards on the cover **B** on the driver's door;
- insert the end of the key **2** into the notch **4** at the bottom of the cover **B**;
- rotate it upwards to remove the cover **B**;
- insert the key **2** into the lock of the driver's door, then lock or unlock.

Once you are inside the vehicle, put the key back in its casing in the card.

DOORS AND OPENING ELEMENTS

Locking the doors manually



With the door open, turn the screw **6** (using the end of the key) and close the door.

This means that the door is then locked from the outside.

The doors may then only be opened from the inside or by using the key in the driver's door.

Interior locking/unlocking door control



The switch **7** controls the doors, the luggage compartment door and the fuel filler flap simultaneously.

If a door or the tailgate is open or not closed properly, the doors and tailgate lock/unlock quickly.

If transporting an object with the luggage compartment open, you can still lock the other doors: with the engine stopped, press and hold switch **7** for more than five seconds to lock the doors.

Door and tailgate status indicator

With the ignition on, the switch **7** warning light indicates the locking status of the opening elements:

- when the warning light is on, the doors and luggage compartment door are locked;
- indicator light off, the doors and tailgate are unlocked.

When you lock the doors, the indicator light remains lit and then goes out.



Driver's responsibility

If you decide to keep the doors locked when you are driving, remember

that it may be more difficult for those assisting you to gain access to the passenger compartment in the event of an emergency.

Locking the opening elements without the card or the key

For example, in the event of a discharged battery or the card or key temporarily not working etc.

With the engine stopped and a door or the luggage compartment door

DOORS AND OPENING ELEMENTS

open, press and hold the switch **7** for more than five seconds.

When the door is closed, all the doors and tailgate will be locked.

Note: it is only possible to unlock the vehicle from the outside while the card is in the vehicle's access zone, or by using the key.



Never leave your vehicle with the key or card inside.

Automatic locking when driving

Operating principle



After the vehicle is started, the system automatically locks the doors when you reach approximately 6 mph (10 km/h).

The door can be unlocked:

- by pressing the door unlocking switch **7**;
- at a standstill, by opening a front door from inside the vehicle.

Note: if a door is opened/closed, it will automatically lock again when the vehicle reaches a speed of approximately 6 mph (10 km/h).

Activating/deactivating the function

To activate it: with the vehicle stationary and the engine running, press the switch **7** until a beep sounds.

To deactivate it: with the vehicle stationary and the engine running, press the switch **7** until you hear two beeps.

The function can also be activated and deactivated via the multimedia screen → **112** (depending on the vehicle).

Operating faults

If you experience an operating fault (no central locking, the switch light **7** does not light up when trying to lock the doors and luggage compartment, etc.), make sure that central locking has not been deactivated by mistake and check that all of the opening ele-

ments are properly closed. If they are properly closed, contact an approved dealer.



Driver's responsibility

If you decide to keep the doors locked when you are driving, remember that it may be more difficult for those assisting you to gain access to the passenger compartment in the event of an emergency.

DOORS AND OPENING ELEMENTS

Luggage compartment

To open

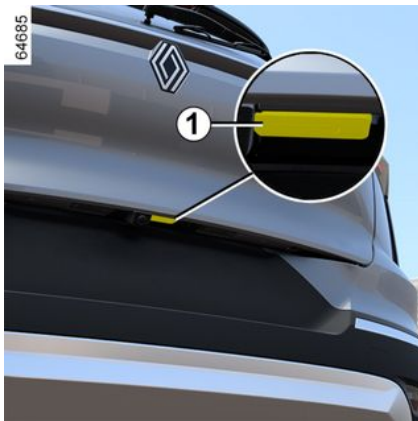

Press button **1** to open the luggage compartment door by a few centimetres.

Lift the luggage compartment lid.

To close



Lower the luggage compartment door starting with the interior handles **2**.



Never use the struts to close the luggage compartment door.

Opening manually from inside the vehicle

If it is impossible to unlock the luggage compartment, it can be done manually from inside:

- access the luggage compartment by folding down the rear bench seatback(s);
- insert a pencil or similar object into the recess **3** and slide the unit as shown in the illustration;
- push the boot lid to open it.



The attaching of any carrying device (bike rack, luggage box etc.) resting on the luggage compartment lid is prohibited. To install a carrying device on your vehicle, contact an approved dealer.

Automatic tailgate

Conditions of use

- Immobilise the vehicle.
- If there is any ice or snow preventing the tailgate from opening, this ice or snow must be removed to free the tailgate.
- In the event that the battery is discharged or if it is replaced, the tailgate should be closed (manually if necessary) to restart the tailgate motor.

DOORS AND OPENING ELEMENTS

Opening/Closing

The opening or closing of the motorised tailgate is indicated by **three sound signals**.



Ensure that nobody is close to the moving parts when opening/closing the tailgate.

Risk of injury.

Depending on the equipment, the tailgate locks and unlocks at the same time as the doors.

There are various ways to handle the tailgate:

- using the card as a remote control;
- using the controls on the tailgate;
- using the dashboard control;
- depending on the vehicle, using the "hands-free" function.



To avoid damaging the tailgate system, do not manually force the tailgate to open or close while it is moving.



As a safety precaution, the doors should only be opened/closed when the vehicle is stationary.

Risk of injury.

using the remote control card



With the engine off, press and hold the switch **1** on the card while near the luggage compartment.

Using the tailgate exterior opening control

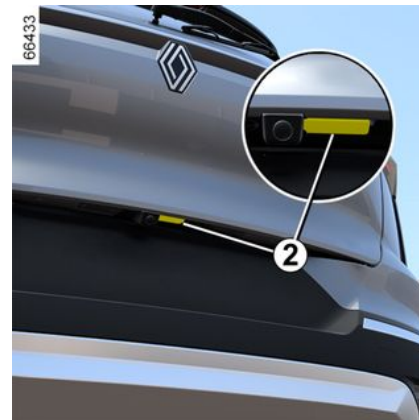

Press the control **2**.

DOORS AND OPENING ELEMENTS

Using the tailgate interior closing control



Press the control **3**.

Using the dashboard control



To open the tailgate, press and hold the switch **4** until you hear the beep, then immediately release the switch.

Note: if the switch is not released quickly enough (within approximately one second) after the beep, the tailgate will not open. In this case, repeat the sequence.

To close the tailgate, press and hold the switch **4** until the tailgate closes completely. A beep sounds throughout the operation.

Note: if you let go of the switch **4** before the tailgate is completely closed, the closing operation is interrupted.

Using the "hands-free" function (depending on the vehicle)



The "hands-free" function enables you to access the luggage compartment when you have your hands full. Ensure that the card is located in the rear area of the vehicle (area **B**). Stand approximately 45 centimetres from the vehicle's rear bumper and move your foot forwards/backwards in area **A**.

The sensor detects the approach and removal of your foot and triggers the opening or closing of the tailgate.

Do not keep your foot in the air. Perform the movement without stopping and without touching the rear bumper.

2

DOORS AND OPENING ELEMENTS

Note: with the tailgate open, after detecting a closure control, it waits around three seconds before triggering the closure (a beep is emitted every second).

Activation/deactivation of the "hands-free" function

(depending on the multimedia system)

From the multimedia screen, access the "Vehicle" world, select the "Vehicle" tab then the "Access" menu. Activate or deactivate "Hands-free locking/unlocking".

Special feature of the "hands-free" function

- The "hands-free" function is no longer available after the vehicle has not been used for a few days, or after around 10 minutes if the vehicle is unlocked. To reactivate it, use the unlocking button on the card.
- The "hands-free" function is only available if the vehicle is stationary and the engine is switched off (and not put on standby using the "Stop and start" function).
- The "hands-free" function may not work if the vehicle is equipped with a towbar or if located in an area with a high electromagnetic radiation.



Deactivate the "hands-free" function before you:

- wash the vehicle in a roller-type car wash;
- wash the vehicle by hand;
- handle the emergency spare wheel or the towing equipment;
- ...

Risk of accidental opening of the tailgate which may cause injury.

Stopping the tailgate manoeuvre

The automatic tailgate manoeuvre can be stopped at any time by a short press on one of the controls.

If the tailgate is stationary in the intermediate position, your next press will move the tailgate in the opposite direction to when you stopped it.

Manual mode

After stopping the tailgate, you can perform the manoeuvre manually if you wish.

You can switch to the automatic manoeuvre at any time by pressing one of the controls.

Obstacle detection

If the tailgate detects an obstacle during its manoeuvre then it will stop. It will then be released from the obstacle following a small movement in the opposite direction, before stopping completely.

Press a tailgate opening/closing control to resume the tailgate operation.

DOORS AND OPENING ELEMENTS



The obstacle detection is an aid to opening and closing the tailgate, it does not in any way replace the user's care or responsibility.

Ensure that nobody is close to the moving parts when opening/closing the tailgate.

When opening/closing the tailgate, small objects may not be detected.

Ensure that no body parts (arms, hands, fingers etc.) are near the moving tailgate parts.

The detection is inactive at the end of the movement, before the tailgate is fully closed.

If the tailgate jams, stop the operation by pressing briefly on one of the controls.

Risk of serious injury.

Limiting the tailgate opening angle

You can adjust the maximum tailgate opening height. It will always stop at the chosen position:

- open the tailgate to an intermediate position;

- manually adjust the tailgate to the chosen position;
- press the motorised tailgate control **3** for more than three seconds to save the position.

Two beeps will sound to notify you that the position has been saved.

User precautions

- Before opening/closing the tailgate, ensure that the surrounding space is sufficient to allow the tailgate to operate.
- Avoid multiple manual stops during the automatic tailgate movement (risk of damaging the tailgate system).
- The "hands-free" system may be temporarily disrupted if the rear bumper is dirty (dirt, mud, snow, gritting salt, etc.). Clean the rear bumper. If there is still a problem, contact an approved dealer.

Operating faults

If you activate the automatic tailgate continuously for around a minute (sequence of opening and closing), it will stop in order to avoid overheating. The operation will return to normal after about a minute.

The automatic tailgate will not operate if the battery is on low charge. In this

case, operate the automatic tailgate with the engine started.

Note: in very cold weather conditions, the automatic opening may not work if the tailgate seals are frozen.



Driver's responsibility when parking or stopping the vehicle

Never leave your vehicle with a child, an adult who is not self-sufficient or a pet inside or at the rear of the tailgate, even for a short while.

They may pose a risk to themselves or to others by starting the engine, activating equipment such as the electric windows, the automatic tailgate or by locking the doors.

RISK OF DEATH OR SERIOUS INJURY.

DOORS AND OPENING ELEMENTS

2



The attaching of any carrying device (bike rack, luggage box, etc.) resting on the luggage compartment lid is prohibited. To install a carrying device on your vehicle, contact an approved dealer.

FRONT SEATS

Front headrests

To raise the headrest

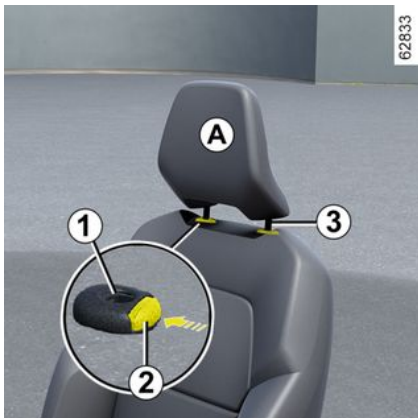

Pull the headrest upwards to the desired height. Check that it is correctly locked.

To lower the headrest

Press the button **2** and guide the headrest down to the desired height. Check that it is correctly locked.

To remove the headrest

Raise it to its highest position (tilt the seatback backwards if necessary).

Press the button **2** and lift the headrest to release it.

To refit the headrest

Check that the headrest rods are clean **3**.

Insert the headrest rods into the holes **1** (tilt the seatback backwards if necessary). Lower the headrest until it locks and press button **2** to adjust to the desired height. Check that each rod **3** is locked on the seatback.

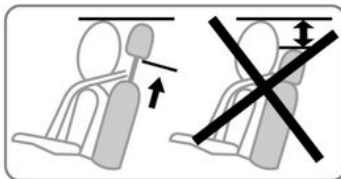

The headrest is an important safety component: ensure that it is in place and in the correct position. The top of your head should be in line with the top of the headrest. The distance between your head and section **A** should be as short as possible.

Front seats

Adjusting the seat position



FRONT SEATS

To move the seat forwards or back

Move the switch **1** forwards or backwards or, depending on the vehicle, lift and hold the handle **3** to unlock the seat. Release the handle once the seat is in the correct position and ensure that the seat is locked.

To raise or lower the seat base

Move the switch **1** upwards or downwards or, depending on the vehicle, move the lever **4** as many times as necessary upwards or downwards to the desired position.

Adjusting the seatback



To tilt the seatback

Move the switch **2** forwards or backwards or, depending on the vehicle, lift the handle **5** and tilt the seatback to the desired position. Release the handle at the desired position and make sure that it is locked.



After making adjustments, make sure that the seatbacks are correctly locked in place.



For safety reasons, carry out any adjustments while the vehicle is stationary.

We would advise you not to recline the seatbacks too far to ensure that the effectiveness of the seat belts is not reduced.

Nothing should be placed on the floor (area in front of the driver) as these objects may slide under the pedals during sudden braking manoeuvres, thus obstructing their use.

Central armrest



(depending on the vehicle)

To adjust the position of the central armrest **6**, slide it forwards or backwards.

FRONT SEATS

To adjust the seat's lumbar position



Lower the handle **7** to increase the support and lift it to decrease it.

Heated seats



Ignition on:

- pressing the switch **8** on the required seat for the first time activates the heating system on high. Both of the built-in warning lights on the switch light up;
- pressing the switch for the second time changes the heating to low. One integrated warning light is illuminated;
- pressing for the third time turns the heating off.

Operating faults

When an operating fault is detected, the warning light of the switch **8** for the seat concerned goes out after approximately five seconds.

Consult an approved dealer.

REAR SEATS

Rear headrests

2

Position for use

The side headrests are not adjustable. Raise the central headrest fully until it locks.

Check that it is correctly locked.

To remove the headrest



Raise the headrest as far as it will go, then press button **1** and remove the headrest.

To refit the headrest

Enter the rods in their housing and push down the headrest until it locks to use it in the high position.

Check that it is correctly locked.

Central headrest storage position 2



Press button **1** and lower the headrest completely.

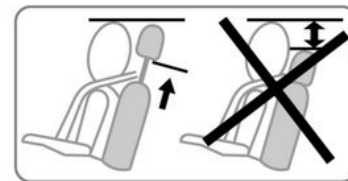

When the headrest is set at the lowest position, this is for storage only: it should not be in this position when the seat is occupied.



The headrest is a safety component; check that it is fitted and in the correct position.

REAR SEATS

Rear bench seat: functions

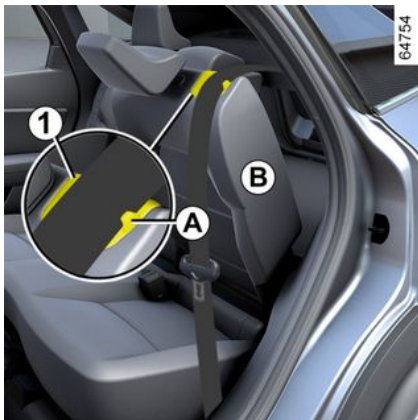

To fold down the seatback

Ensure that the front seats are far enough forward.

Before folding down a seatback:

- lower the headrests fully;
- place the seat belt in the belt guide **A** and buckle the seat belt. This prevents the seat belt from locking when the seatback is lifted up again.

Pull the handle **1** and lower the seatback **B**.

Note: for safety reasons, the seatback **B** is equipped with a retaining system. You may experience resistance when handling.

To replace the seatback, proceed in the reverse order to removal.

Raise the seatback again until it reaches the locking joint of the seatback.

Be careful not to jam the safety strap between the backrest and the parcel shelf.

Check the operation of the seat belt.

 Before moving the seatback, put seat belt in belt guide **A** to avoid damaging it.



When refitting the seatback, make sure it is correctly locked in place. **If seat covers are fitted**, make sure these do not prevent the seatback latch from locking in.

Make sure that the seat belts are positioned correctly.
Reposition the headrests.

To move a seat forwards or backwards



Raise the lever **2** from the rear seats to unlock the bench seat.

Move the seat forwards or back to the required position.

Release the lever **2** and ensure that the bench seat is properly locked.



For safety reasons, carry out any adjustments while the vehicle is stationary.

2

REAR SEATS

2



When moving the rear seats, ensure that nothing obstructs the anchorage points (passenger's arm or leg, a pet, gravel, cloth, toys, etc.).

SEAT BELTS

Seat belts

Always wear your seat belt when travelling in your vehicle. You must also comply with the legislation of the particular country you are in.

Before starting, first adjust your driving position, then ask all occupants to adjust their seat belts to ensure optimum protection.

Adjusting your driving position

- **Sit well back in your seat** (having removed your coat or jacket, etc.). This is essential to ensure that your back is positioned correctly;
- **adjust the distance between the seat and the pedals.** Your seat should be as far back as possible while still allowing you to fully depress the pedals. The seatback should be adjusted so that your arms are slightly bent when you hold the steering wheel;
- **adjust the position of your headrest.** For maximum safety, your head must be as close as possible to the headrest;
- **adjust the height of the seat.** This adjustment allows you to select the seat position which offers you the best possible view;
- **adjust the position of the steering wheel.**



Make sure that the rear bench seat → 52 is locked in position correctly so that the rear seat belts will operate correctly.



Incorrectly adjusted or twisted seat belts may cause injuries in the event of an accident.

Use one seat belt per person, whether child or adult. Even pregnant women should wear a seat belt. In this case, ensure that the lap belt is not exerting too much pressure on the abdomen, but do not allow any slack.

Adjusting the seat belts



To ensure the correct adjustment and positioning of the seat belts on all seats:

- adjust the seats (seat position and seatback angle, if available);
- sit with your back firmly against the seatback;
- move the shoulder strap **1** as close as possible to the base of the neck without it actually resting against it (if necessary, adjust the height of the seat belt if available) and make sure that the chest strap **1** is in contact with the shoulder;
- position the lap belt **2** so that it lies flat on the thighs and against the pelvis.

SEAT BELTS

The seat belt must be worn as close to the body as possible. e.g. avoid wearing heavy clothing, keeping bulky objects under the belts, etc.

Locking

Unwind the belt **slowly and smoothly** and ensure that the buckle **3** locks into the catch **5** (check that it is locked by pulling on the buckle **3**).

If the belt jams, allow it to return slightly before attempting to unwind it again.

If your seat belt is completely jammed, pull slowly, but firmly, so that just over 3 cm unwinds. Allow it to return slightly before attempting to unwind it again.

If there is still a problem, contact an approved dealer.

Unlocking

Press the button **4** and the seat belt will be rewound by the inertia reel. Guide the belt.

Seat belt reminder warning lights

This warning light appears on the central display **A** when the vehicle ignition is switched on and if the driver's and/or front passenger's seat belt(s) (if the passenger seat is occupied) is not fastened.



Front seat belt reminder



With the doors closed, the graphic **6** is displayed on the instrument panel for approximately 60 seconds when the vehicle ignition is switched on. This informs the driver of the fastening status of each of the front seat belts every time:

- the doors are opened during driving (vehicle speed above zero);
- a front seat belt is fastened/unfastened.

Understanding the graphic **6**:

- symbol in green: seat belt fastened;
- symbol in red: the seat is occupied and the seat belt is not fastened;
- symbol in grey: seat not occupied.

With the doors closed, the  warning light appears on the central display when the vehicle ignition is switched on if the driver's and/or front passenger's seat belt(s) (if this seat is occupied) are not fastened.

When the vehicle speed is less than approximately 12 mph (20 km/h), the

 warning light appears on the central display if a front seat is occupied and the seat belt is not fastened.

It is accompanied by the graphic **6** which appears for approximately 60 seconds each time one of the front seat belts is fastened or unfastened.

SEAT BELTS

When the vehicle speed exceeds approximately 12 mph (20 km/h), if one of the front seat belts is or becomes unfastened during the journey:

- the  warning light flashes on the central display;
- and
- a beep sound for approximately 120 seconds;
- and
- the graphic **6** is displayed for approximately 180 seconds and the symbol for the seat concerned changes to red.

Always make sure that the front passengers are properly fastened in and that the number of seat belts indicated as fastened corresponds to the number of front seats occupied.

Note: an object placed on the passenger seat may activate the warning light in some cases.

Rear seat belt reminder

With the doors closed, the graphic **6** is displayed on the instrument panel for approximately 60 seconds when the vehicle ignition is switched on. This informs the driver of the fastening status of each of the front seat belts every time:

- the doors are opened during driving (vehicle speed above zero);
- a front seat belt is fastened/unfastened.

Understanding the graphic **6**:

- symbol in green: seat belt fastened;
- symbol in red: the seat is occupied and the seat belt is not fastened;
- symbol in grey: seat not occupied.

Depending on the vehicle, with the doors closed the  warning light on the central display also appears when the ignition is switched on and if a rear seat is occupied and the seat belt is not fastened.

When the vehicle speed is less than approximately 12 mph (20 km/h), the

 warning light on the central display appears when a rear seat belt is unfastened.

It is accompanied by the graphic **6** which appears for approximately 60 seconds each time one of the rear seat belts is fastened or unfastened.

When the vehicle speed exceeds approximately 12 mph (20 km/h), if one of the rear seat belts is or becomes unfastened during the journey:

- the  warning light flashes on the central display;

- and
- a beep sounds for around 30 or 120 seconds;
- and
- the graphic **6** is displayed for at least 60 seconds or, depending on the vehicle, approximately 180 seconds and the symbol for the seat concerned changes to red.

Always make sure that the rear passengers are properly fastened and that the number of fastened seat belts indicated corresponds to the number of rear seats occupied.

Note: an object placed on one of the rear passenger seat bases may activate the warning light in some cases.

SEAT BELTS

Adjusting the height of the front seat belts

2



Press the button **7** to adjust the seat belt height, so that the shoulder strap is worn as shown previously. Press the button **7** and raise or lower the seat belt. Make sure that the seat belt is locked in position correctly after you have adjusted it.

Rear seat belts

Rear side seat belts

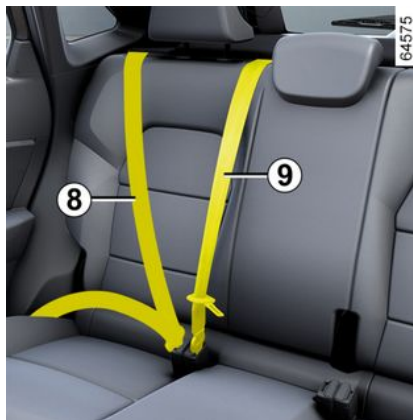

The locking, unlocking and adjustment of the rear side seat belts **8** is carried out in the same way as for the front seat belts.



Check that the rear seat belts are positioned and operating correctly each time the rear bench seat is moved.

Rear centre seat belt

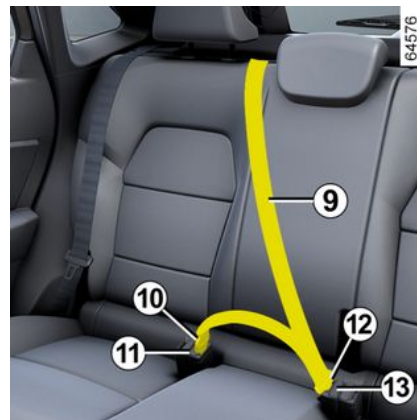

Slowly unwind the belt **9**.

Click the buckle **10** into the black catch **11**.

Fasten the buckle **12** into the red catch unit **13**.



Ensure that you always leave the buckle **10** fastened in the catch **11** even if no passenger is present in the centre seat.

SEAT BELTS

Warnings

The following information applies to the vehicle's front and rear seat belts.



- No modification must be made to the originally-fitted restraint system components (seat belts, seats and their mountings). For special operations (e.g. fitting child seats) please contact an approved dealer.
- Do not use devices which give any slack in the belts (e.g. clothes pegs, clips, etc.), as a seat belt which is worn too loosely risks causing injury in the event of an accident.
- Never wear the shoulder strap under your arm or behind your back.
- Never use the same belt for more than one person and never hold a baby or child on your lap with your seat belt around them.
- The belt should never be twisted.
- Following an accident, have the seat belts checked and replaced if necessary. Always replace your seat belts as soon as they show any signs of wear.
- When the rear bench seat is being put back, make sure that the seat belts and buckles are correctly positioned so that they can be used properly.
- Make sure that the seat belt buckle is inserted into the appropriate catch.
- Ensure that no objects are placed in the area around the seat belt catch as they could prevent it from being properly secured.
- Make sure the seat belt catch is properly positioned (it should not be hidden away, crushed or flattened by people or objects).

ADDITIONAL SAFETY DEVICES

2

Methods of restraint in addition to the front seat belts

Depending on the vehicle, they may comprise:

- **seat belt inertia reel pretensioners;**
- **lap seat belt pretensioners;**
- **chest force limiters;**
- **airbags driver and passenger front.**

These systems are designed to act independently or together when the vehicle is subjected to a frontal impact.

Depending on the severity of the impact, the system can cause:

- blocking of the seat belt;
- the seat belt inertia reel pretensioner which is triggered to correct seat belt slack;
- the lap seat belt pretensioner to hold the occupant in their seat;
- the front airbag.

Pretensioners

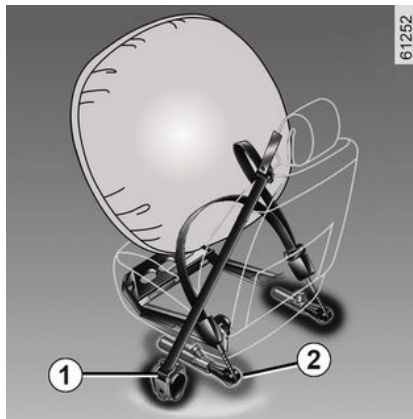

The pretensioners hold the seat belt against the body, holding the occupant more securely against the seat, thus increasing the seat belt's efficiency.

In the event of a severe frontal impact and if the ignition is switched on, the system may engage the following depending on the force of the impact:

- the seat belt inertia reel pretensioner **1** which instantly retracts the seat belt;
- the lap seat belt inertia reel pretensioner **2** on the front seats.



- Have the entire restraint system checked following an accident.
- No operation whatsoever is permitted on any part of the system (pretensioners, Airbags, computers, wiring) and the system components must not be reused on any other vehicle, even if identical.
- Only qualified personnel from our Network may work on the Airbags; otherwise the system may trigger accidentally and cause injury.
- The electrical trigger system may only be tested by a specially trained technician using special equipment.
- When the vehicle is scrapped, contact an approved dealer for disposal of the pretensioner and Airbags gas generators.

Load limiter

Above a certain severity of impact, this mechanism is used to limit the force of the belt against the body so that it is at an acceptable level.

ADDITIONAL SAFETY DEVICES

Driver and passenger front airbags

Fitted to the driver and passenger sides.

A symbol on the lower section of the windscreen indicates if this equipment is present (depending on the vehicle).

Each airbag system consists of:

- an airbag and gas generator fitted on the steering wheel for the driver and in the dashboard for the front passenger;
- an electronic unit for monitoring the system controlling the gas generator electrical trigger;
- remote sensors;
- a single  warning light on the instrument panel.



The airbag system uses pyrotechnic principles. This explains why, when the airbag inflates, it will generate heat, produce smoke (this does not mean that a fire is about to start) and sound like a detonation. In a situation where an airbag deployment is required, it will inflate immediately and this may cause some minor, superficial grazing to the skin or other problems.



Operation

This system is only operational when the ignition is switched on.

In a severe frontal impact, the airbags inflate rapidly, cushioning the impact of the driver's head and chest against the steering wheel and of the front passenger against the dashboard. The airbags then deflate immediately so that the passengers are not in any way prevented from leaving the vehicle.

Operating faults



This warning light comes on when the engine is started and then goes out after approximately three seconds.

If it does not come on when the ignition is switched on or if it stays on, there is a fault in the system.

Contact your approved Dealer as soon as possible;

Your protection will be reduced until this fault is rectified.

ADDITIONAL SAFETY DEVICES

2

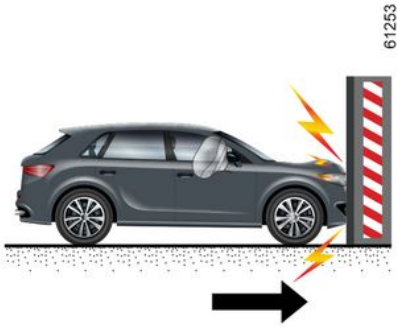

The following cases trigger the pretensioners or airbags.

In a frontal impact against a rigid (non-deformable) surface at an impact speed equal to or greater than 16 mph (25 km/h).

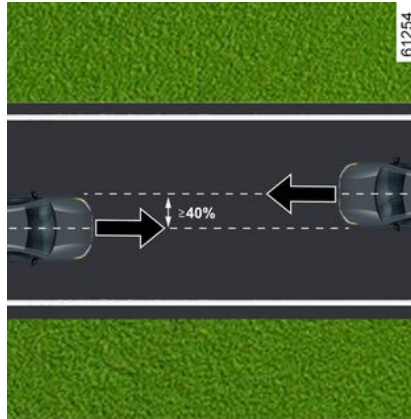

In the event of a frontal impact with another vehicle of an equivalent or higher category, with an impact area equal to or greater than 40%, where the speed of both vehicles is equal to or greater than 25 mph (40 km/h).

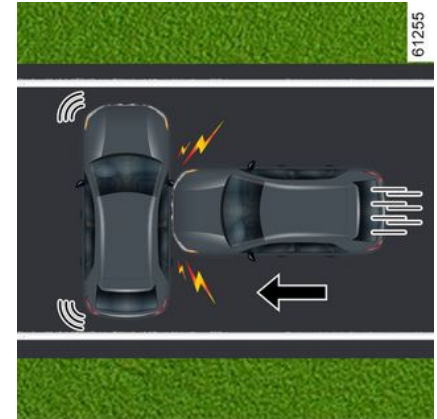

In a side impact with another vehicle of an equivalent or higher category, at an impact speed equal to or greater than 31 mph (50 km/h).

ADDITIONAL SAFETY DEVICES

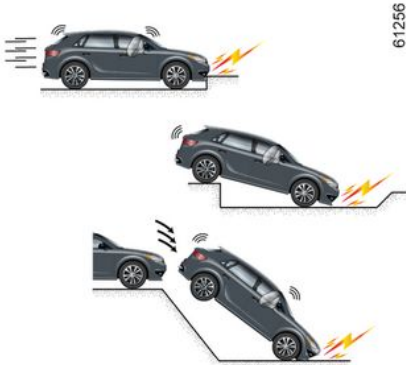

The pretensioners or airbags may be triggered in the following cases:

- an impact underneath the vehicle (e.g. pavement kerb);
- potholes;
- a drop or hard landing;
- stones;
- ...



In the following examples, the pretensioners or airbags might not be triggered:

- a rear impact, however severe;
- the vehicle overturning;



- side impact at the front or rear of the vehicle;
- frontal impact, underneath the tail of a lorry;
- frontal impact against an obstacle with a sharp angle;
- ...

ADDITIONAL SAFETY DEVICES

Warnings

2

All of the warnings below are given so that the airbags not obstructed in any way when it is inflated and also to prevent the risk of serious injuries caused by items which may be dislodged when it inflates.



Warnings in relation to the driver's airbag

- Do not modify the steering wheel or the boss.
- Do not cover the steering wheel boss under any circumstances.
- Do not attach any objects (badge, logo, watch, telephone cradle, etc.) to the steering wheel boss.
- The steering wheel must not be removed (except by qualified personnel from our Network).
- Do not sit too close to the steering wheel: sit with your arms slightly bent (see "Adjusting your driving position" → 55). This will allow sufficient space for the airbag to deploy correctly and be fully effective.

Warnings in relation to the passenger's airbag

- Do not attach or glue any objects (badge, logo, clock, telephone holder, etc.) to the dashboard over or near the airbag.
- Do not place anything between the dashboard and the passenger (animal, umbrella, walking stick, parcels, etc.).
- The passenger must not put his or her feet on the dashboard or seat as there is a risk that serious injuries may be sustained. As a general rule, parts of the body should be kept away from the dashboard (knees, hands, head, etc.).
- the devices in addition to the front passenger seat belt should be reactivated as soon as a child seat is removed, to ensure the protection of the passenger in the event of an impact.

A REAR-FACING CHILD SEAT MUST NOT BE FITTED TO THE FRONT PASSENGER SEAT UNLESS THE ADDITIONAL RESTRAINT SYSTEMS ARE NOT DEACTIVATED → 92.

ADDITIONAL SAFETY DEVICES

Methods of restraint in addition to the rear seat belts

Depending on the vehicle, they may comprise:

- **side seat belt inertia reel pretensioners;**
- **chest force limiters.**

These systems are designed to act independently or together when the vehicle is subjected to a frontal impact.

Depending on the severity of the impact, the system can cause:

- blocking of the seat belt;
- the seat belt inertia reel pretensioner (which engages to correct seat belt slack).

Load limiter

Above a certain severity of impact, this mechanism is used to limit the force of the belt against the body so that it is at an acceptable level.

Side seat belt pretensioners

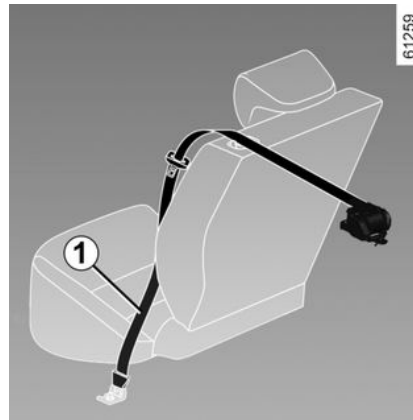

The pretensioners hold the seat belt against the body, holding the occupant more securely against the seat, thus increasing the seat belt's efficiency.

With the ignition on, following a significant frontal impact and depending on the severity of the impact, the system may trigger the seat belt inertia reel pretensioner **1** which instantly retracts the seat belt.



- Have the entire restraint system checked following an accident.
- No operation whatsoever is permitted on any part of the system (pretensioners, airbags, computers, wiring) and the system components must not be reused on any other vehicle, even if identical.
- Only qualified personnel from our Network may work on the pretensioners and airbags, otherwise the system may trigger accidentally and cause injury.
- The electrical trigger system may only be tested by a specially trained technician using special equipment.
- If scrapping your vehicle, contact an approved dealer for disposal of the gas generator of the pretensioners and airbags.

Side protection devices

Side airbag

This airbag may be fitted to each of the front seats and is activated at the sides

ADDITIONAL SAFETY DEVICES

of the seats (door side) to protect the occupants in the event of a severe side impact.

2

Curtain airbag

This is an airbag fitted (depending on the vehicle) along the upper sides of the vehicle – they inflate along the front and rear door side windows to protect the passengers in the event of a severe side impact.



Warning related to the side airbag

– Fitting seat covers:

seats equipped with an airbag require covers specifically designed for your vehicle. Contact an approved dealer to find out if these covers are available. The use of any covers other than those designed for your vehicle (including those designed for another vehicle) may affect the operation of the airbag and reduce your protection.

– Do not place any accessories, objects or even pets between the seatback, the door and the internal fittings. Do not cover the seatback with objects such as clothes or accessories. This may prevent the airbag from operating correctly or cause injury when the airbag is deployed.

– No work or modification whatsoever may be carried out on the seat or internal fittings, except by qualified personnel from our Network.

– The airbag is deployed through slits in the front seatbacks (door side): never insert any objects into these slits.

ADDITIONAL SAFETY DEVICES

Additional methods of restraint

All of the following warnings are intended to ensure that the airbag is not obstructed in any way when it is inflated and also to prevent the risk of serious injuries caused by items which may be projected when it inflates.

2



The airbag is designed to complement the action of the seat belt. Both the airbag and the seat belt are integral parts of the same protection system. It is therefore essential to wear seat belts at all times. If seat belts are not worn, the occupants are exposed to the risk of serious injury in the event of an accident. It may also increase the risk of minor superficial injuries occurring when the airbag is deployed, although such minor injuries are always possible with airbags.

If the vehicle should overturn or suffer a rear impact, however severe, the pretensioners and airbags are not always triggered. Shocks to the underbody of the vehicle, from pavements, potholes, stones etc. can all trigger these systems.

- Any work or modification on any part of the airbag (airbags, pretensioners, computer, wiring harness, etc.) **is strictly prohibited** (except by qualified personnel from the network).
- To ensure that the system is in good working order and to avoid accidental triggering of the system which may cause injury, only qualified personnel from the network may work on an airbag system.
- As a safety precaution, have the airbag system checked if your vehicle has been involved in an accident, or is stolen or broken into.
- When selling or lending the vehicle, inform the new purchaser of these conditions when handing over this vehicle user manual.
- When scrapping your vehicle, contact your approved dealer for disposal of the gas generator(s).

CHILD SAFETY

General information

2

Carrying children

Please ensure that you comply with the legislation of your country.

Children, and adults, must be correctly seated and strapped in for all journeys. The children being carried in your vehicle are your responsibility.

A child is not a miniature adult. Children are at risk of specific injuries as their muscles and bones have not yet finished growing. The seat belt alone would not provide suitable protection. Use an approved child seat and ensure you use it correctly.



To prevent the doors being opened, use the "Child lock" feature → 38.



A collision at 31 mph (50 km/h) is the same as falling a distance of 10 metres.

Transporting a child without a restraint is the equivalent of allowing him or her to play on a fourth-floor balcony without railings. Never travel with a child held in your arms.

In the event of an accident, you will not be able to keep hold of the child, even if you yourself are wearing a seat belt.

If your vehicle has been involved in a road accident, replace the child seat and have the seat belts and ISOFIX anchorage points checked.



Driver's responsibility when parking or stopping the vehicle

Never leave an animal, child or adult who is not self-sufficient alone in your vehicle, even for a short time.

They may pose a risk to themselves or to others by starting the engine, activating equipment such as the electric windows or by locking the doors.

Also, in hot and/or sunny weather, please remember that the temperature inside the passenger compartment increases very quickly.

RISK OF DEATH OR SERIOUS INJURY.

Using a child seat

The level of protection offered by the child seat depends on its ability to restrain your child and on its installation. Incorrect installation compromises the protection it offers the child in the event of harsh braking or an impact.

Before purchasing a child seat, check that it complies with the regulations for the country you are in and that it can be fitted in your vehicle. Consult an ap-

CHILD SAFETY

proved Dealer to find out which seats are recommended for your vehicle.

The regulations on transporting children are specific to each country. The use of a child seat during transport depends on the age and/or the size and/or weight of the child.

For children who do not need to be transported in a child seat, make sure that the seat belt is correctly adjusted and fastened.

In all cases, you must comply with the regulations of the particular country you are in.

Before fitting a child seat, read the manual and respect its instructions. If you experience any difficulties during installation, contact the manufacturer of the equipment. Keep the instructions with the seat.



Set a good example by always fastening your seat belt and teaching your child:

- to strap themselves in correctly;
- to always get in and out of the car at the kerb, away from busy traffic.

Do not use a second-hand child seat or one without an instruction manual.

Check that there are no objects in the vicinity of the child seat which could impede its operation.



Never leave a child unattended in the vehicle.

Check that your child is always strapped in and that the belt or safety harness used is correctly set and adjusted.

Avoid wearing bulky clothing which could cause the belts to slacken → 55.

Never let your child put their head or arms out of the window.

Check that the child is in the correct position for the entire journey, especially if asleep.

CHILD SAFETY

Choosing a child seat

Rear-facing child seats

2



61260

A baby's head is, proportionally, heavier than that of an adult and its neck is very fragile. Transport the child in this position as long as possible (until the age of 2 at the very least). It supports both the head and the neck.

Choose a bucket type seat for best side protection and change it as soon as the child's head is higher than the shell.

Forward-facing child seats



61261

Up to 18 kg or 4 years, the child may travel on a forward-facing seat.

Choose a seat according to the child's size: their head and abdomen are the areas which require most protection. A forward-facing child seat which is firmly attached to the vehicle will reduce the risk of impact to the head. Ensure your child travels in a forward-facing seat with a harness for as long as their size permits.

Choose a bucket type seat for optimum side protection.w

Booster cushions



61262

From 15 kg or 4 years, the child can travel using a booster seat, which will enable the seat belt to be adapted to suit his size and shape. The booster seat cushion must be fitted with guides to position the seat belt on the child's thighs rather than the stomach. It is recommended that you use a seatback which can be adjusted in terms of height to position the seat belt in the centre of the shoulder. It must never rest on the neck or on the arm.

Choose a bucket type seat for optimum side protection.w

CHILD SAFETY



List of manufacturer's recommended methods of restraint for children:



63133

Choosing a child seat mounting

There are two ways to attach child seats: using the seat belt or using the ISOFIX system.

Attachment via the seat belt

The seat belt must be adjusted in order to ensure it works in the event of sudden braking or impact.

Ensure that the strap paths indicated by the child seat manufacturer are observed.

Always check that the seat belt is correctly fastened by pulling it up, then pulling it out fully whilst pressing on the child seat.

Check that the seat is correctly held by moving it from side to side and back to front: the seat should remain firmly fixed.

Check that the child seat has not been installed at an angle and that it is not resting against a window.



Do not use the child seat if it risks unfastening the seat belt restraining it: the base of the seat

must not rest on the buckle and/or catch of the seat belt.



The seat belt must never be twisted or the tension relieved. Never pass the shoulder strap under the

arm or behind the back.

Check that the seat belt has not been damaged by sharp edges. If the seat belt does not operate normally, it will not protect the child. Consult an approved Dealer. Do not use this seat until the seat belt has been repaired.

Attachment using the ISOFIX system

Authorised ISOFIX child seats are approved in accordance with current regulations if any of the four cases below applies:

- universal ISOFIX 3-point forward-facing seat;
- semi-universal ISOFIX 2-point seat;
- vehicle-specific;
- i-Size which has either:
 - a strap which attaches to the third ring of the seat concerned;
 - or a strut that rests on the vehicle floor, compatible with the i-Size approved seat, the role of which is to

CHILD SAFETY

prevent the child seat from moving in the event of a collision.

In the latter three cases check that your child seat can be installed by consulting the list of compatible vehicles.



No modifications must be made to the original-fitted restraint system components: seat belts, ISOFIX and seats and their mountings.

Attach the child seat using the ISOFIX locks, if equipped. The ISOFIX system allows quick, easy and safe fitting.

The ISOFIX system consists of 2 rings and, in some cases, a third ring.



The ISOFIX anchoring points have been exclusively designed for child seats equipped with the ISOFIX system. Never fit a different type of child seat, seat belt or other objects to these fittings. Check that nothing is obstructing the anchorage points. If your vehicle has been involved in a road accident, have the ISOFIX anchorage points checked and replace your child seat.



Before using an ISOFIX child seat that you purchased for another vehicle, check that its installation is authorised. Consult the list of vehicles which can be fitted with the seat with the equipment manufacturer.

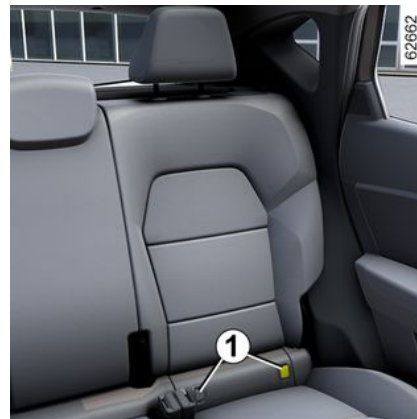

The two rings are located behind the zip fasteners **1** between the seat back and seat base and are identified by a

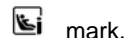

mark.

The third ring **4** is used to attach the upper strap on some child seats. **2** on some child seats.

Rear seats

CHILD SAFETY

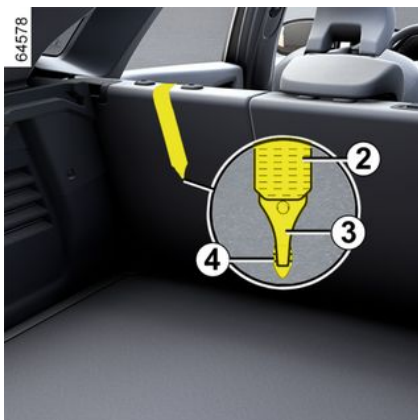

The upper strap **2** should be positioned between the seatback and the rear parcel shelf. To do so, remove the rear parcel shelf → **304**.

Attach the hook **3** to one of the rings **4**

marked by the  symbol.

Front passenger seat

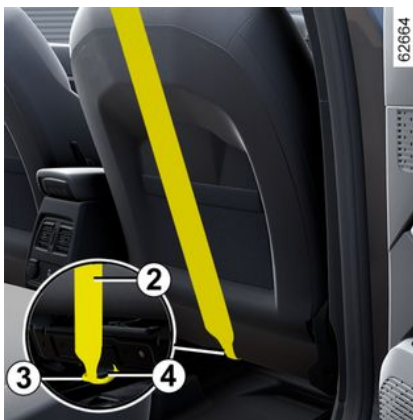

Attach the hook **3** of the upper strap **2**

to the ring **4** identified by the  symbol.

All seats

Pull the upper strap **2** so that the back of the child seat comes into contact with the back of the vehicle seat.



The ISOFIX anchoring points have been exclusively designed for child seats equipped with the ISOFIX system. Never fit a different type of child seat, seat belt or other objects to these fittings. Check that nothing is obstructing the anchorage points. If your vehicle has been involved in a road accident, have the ISOFIX anchorage points checked and replace your child seat.



Check that the seatback of the forward-facing child seat is in contact with the seatback of the vehicle seat. In this case, the child seat may not always rest on the seat base of the vehicle seat.

CHILD SEATS

Fitting a child seat, general information

Some seats are not suitable for fitting child seats. The diagram indicates where to fit a child seat.



Fit the child seat in a rear seat wherever possible.

Make sure the child seat or the child's feet do not prevent the front seat from locking correctly → 49 → 52.

Check that when installing the child seat in the vehicle it is not at risk of coming loose from its base. If you have to remove the headrest, check that it is correctly stored so that it does not come loose under harsh braking or impact.

Always attach the child seat to the vehicle even if it is not in use so that it does not come loose under harsh braking or impact.

The types of child seats indicated may not be available. Before using a differ-

ent child seat, check with the manufacturer that it can be fitted.

In the front seat

The laws concerning children travelling in the front passenger seat differ in every country. Consult the relevant legislation and follow the indications on the diagram.

Before fitting a child seat in this seat (if authorised):

- lower the seat belt as far as possible;
- move the seat as far back as possible;
- gently tilt the seatback away from the vertical position (approximately 25°);
- on equipped vehicles, raise the seat base as far as possible.

Always fully raise the seat headrest so that it does not interfere with the child seat → 49.

After installing the child seat, when this is possible, you can move the vehicle seat forward if necessary (so as to leave enough space in the rear seats for passengers or other child seats). For a rear-facing child seat, do not let it touch the dashboard or move it to the furthest forward position.

Do not change other settings after installing the child seat.



RISK OF DEATH OR SERIOUS INJURY: be-

fore fitting a rear facing child seat on the front passenger seat, check that the airbag has been deactivated

→ 92.

In the rear side seat

A carrycot can be installed across the vehicle and will take up at least two seats. Position the child with his or her feet nearest the door.

In order to install a rear-facing child seat, move the front seat as far forward as possible, then move the front seat back as far as it will go, without allowing it to come into contact with the child seat.

For the safety of the child in the forward-facing position:

- move the seat in which the child will be seated as far back as possible;
- Move the seat in front of the child forwards, and set the position of the seatback to avoid contact between the seat and the child's legs.

CHILD SEATS



Ensure that the child seat or the child's feet do not prevent the locking in place of the seat in front

→ 52 or → 49.

In all situations, remove the headrest of the rear seat on which the child seat is positioned → 52. If necessary, position the rear seat as far back as possible. This must be done before fitting the child seat. Check that the child seat is resting against the back of the rear seat.



Installing a booster seat (group 2 or 3)

Check that the seat belt → 55 operates (winds)

correctly.

Adjust the seat belt by positioning:

- the shoulder strap on the child's shoulder without it touching their neck;
- the lap belt so that it lies flat on the thighs and against the pelvis.

If necessary, adjust the position of the vehicle seat.



A child seat with floor supports must never be installed on the rear centre seat.

RISK OF DEATH OR SERIOUS INJURY.



Fit the child seat in a rear seat wherever possible.

To install an ISOFIX child seat on this seat, unbuckle the seat belts by hand before engaging the bolts.



Fitting an ISOFIX child seat on the rear left-hand seat will mean that the central seat cannot be used. The central seat belt will no longer be either accessible or useable.

CHILD SEATS

Attachment by seat belt

2

Fitting diagram

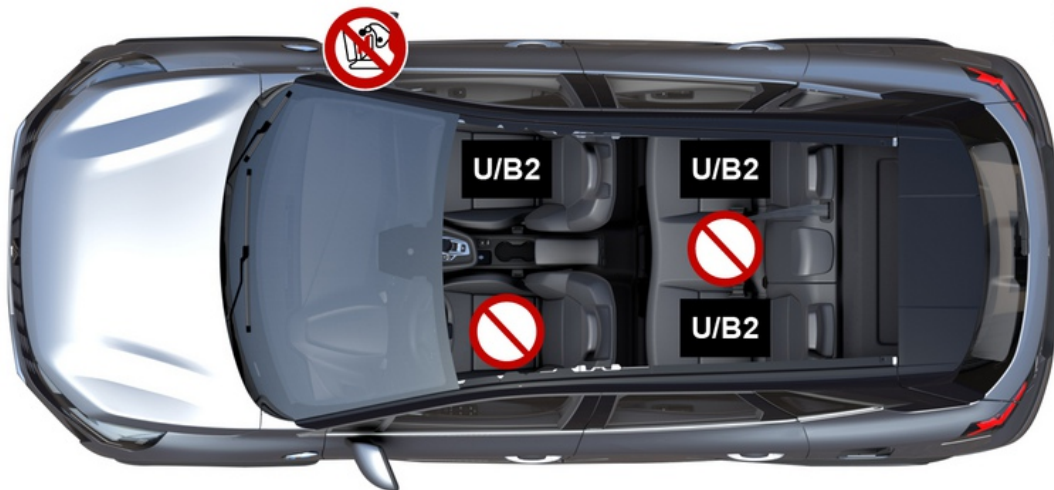

66532

CHILD SEATS



Check the status of the airbag before fitting a child seat or allowing a passenger to use the seat.



Seat not suitable for fitting child seats.

Child seat attached using the belt



Seat equipped for attaching a "universal" approved seat using a seatbelt.



Seat enabling a child seat with "B2" approval to be attached by seat belt.



RISK OF DEATH OR SERIOUS INJURY: before fitting a rear facing child seat on the front passenger seat, check that the airbag has been deactivated → 92.



Using a child safety system which is not approved for this vehicle will not properly protect the baby or child. They risk serious or even fatal injury.



Check that your child is always strapped in and that the belt or safety harness used is correctly set and adjusted → 55.
If necessary, adjust the seat position accordingly.

CHILD SEATS

Installation table

2

The table below summarises the information shown on the installation diagram in order to ensure the regulations in force are respected.

Type of child seat	Weight of the child	Front passenger seat		Rear side seats	Rear centre seat
		With airbag deactivated	With airbag activated		
Carrycot fitted across the vehicle Group 0	< 10 kg (22 lbs)	X	X	U (2)	X
Rear-facing shell seat Groups 0 or 0 +	< 10 kg (22 lbs) and < 13 kg (28.7 lbs)	U (1) (5)	X	U (3)	X
Shell seat/rear-facing seat Groups 0+ and 1	< to 13 kg (28.7 lbs) and 9 (19.7 lbs) to 18 kg (39.7 lbs)	U (1) (5)	X	U (3)	X
Forward-facing seat Group 1	9 to 18 kg (19.7 to 39.7 lbs)	X	U (5)	U (4)	X
Booster seat Groups 2 and 3	15 to 25 kg and 22 to 36 kg (33.1 to 55.1 lbs and 48.5 to 79.4 lbs)	X	U (5) / B2 (6)	U / B2 (4)	X

CHILD SEATS



(1) RISK OF DEATH OR SERIOUS INJURY: before fitting a rear-facing child seat in this seat, make sure that the front passenger airbag has been deactivated → 92.

2

X = Seat not suitable for fitting child seats of this type.

U = Seat enabling a child seat with "Universal" approval to be attached by seat belt: check that it can be fitted.

B2 = Boosters in groups 2 and 3 (15 to 25 kg and 22 to 36 kg/33.1 to 55.1 lbs and 48.5 to 79.4 lbs).

(2) A carrycot can be installed across the vehicle and will take up at least two seats. Position the child with his or her feet nearest the door.

(3) If necessary, position the vehicle seat as far back as possible. In order to install a rear-facing child seat, move the front seat as far forward as possible, then move the front seat back as far as it will go, without allowing it to come into contact with the child seat.

(4) Always retract the headrest of the rear seat on which the child seat is positioned. This action must be performed before fitting the child seat → 52. Move the seat in front of the child forwards, move the seatback forward to avoid contact between the seat and the child's legs.

(5) Raise the seat to the maximum and position it as far back as possible, tilting the seatback slightly (approximately 25°).

(6) Raise the seat to the maximum and position it as far back as possible, tilting the seatback slightly (approximately 25°). The child seat must not be in contact with the centre console or the dashboard.

CHILD SEATS

Attachment using the ISOFIX system

2

Fitting diagram

Version with front passenger seat equipped with ISOFIX



CHILD SEATS

2



For the front passenger seat, the use of a child seat with a floor support is recommended to avoid triggering the seat belt warning signal.



Using a child safety system which is not approved for this vehicle will not properly protect the baby or child. They risk serious or even fatal injury.



Seat which does not allow a child seat to be fitted.

Child seat attached using the ISOFIX system



Seat equipped for attaching a ISOFIX or i-Size child seat.



The front and rear seats are equipped with an anchorage point allowing an ISOFIX universal forward-facing child seat to be attached. The anchoring points are located on the passenger seatback for the front seat and on the bench seatback for the rear seats.



RISK OF DEATH OR SERIOUS INJURY:

before fitting a rear facing child seat on the front passenger seat, check that the airbag has been deactivated
→ 92.



Fit the child seat in a rear seat wherever possible.

To install an ISOFIX seat in this seat, unbuckle the seat belt by hand before engaging the bolts.

CHILD SEATS

2



Fitting a seat ISOFIX in the rear-left seat means the middle seat cannot be used. The central seat belt will no longer be either accessible or useable.

CHILD SEATS

Installation table

Version with front passenger seat equipped with ISOFIX

The table below summarises the information shown on the installation diagram in order to ensure the regulations in force are respected.

Type of child seat	Weight of the child	Size of seat [fixture]	Front passenger seat		Rear side seats	Rear centre seat
			Without airbag or with airbag deactivated	With airbag activated		
Carrycot fitted across the vehicle Group 0	< 10 kg (22 lbs)	L1 [F] L2 [G]	X	X	X	X
Rear-facing shell seat Groups 0 or 0 +	< 13 kg	R1 [E]	IL (1) (5)	X	IL (2)	X
Rear-facing seat Groups 0+ and 1	< to 13 kg (28.7 lbs) and 9 (19.7 lbs) to 18 kg (39.7 lbs)	R3 [C] R2 [D]	IL (1) (5)	X	IL (2)	X
Forward-facing seat Group 1	9 to 18 kg (19.7 to 39.7 lbs)	F3 [A] F2 [B] F2X [B1]	X	IUF - IL (1)	IUF - IL (2)(3)	X
Booster seat Groups 2 and 3	15 to 25 kg and 22 to 36 kg (33.1 to 55.1 lbs and	B2	X	IUF - IL (4)	IUF - IL (2) (3)	X

CHILD SEATS

Type of child seat	Weight of the child	Size of seat [fixture]	Front passenger seat		Rear side seats	Rear centre seat
			Without airbag or with airbag deactivated	With airbag activated		
	48.5 to 79.4 lbs)	B3	X	X	X	X
Seati-Size	Rear-facing seat		i - U (1) (5)	X	i - U (2)	X
	Forward-facing seat		X	i - UF (1)	i - UF (2) (3)	X
	Booster seat		X	i - UF (4)	i - UF (2) (3)	X

X = Seat not suitable for fitting child seats.

IUF = Seat allowing a child seat with "Universal or vehicle-specific" approval to be attached using the ISOFIX system on equipped vehicles; check that it can be fitted.

IL = Seat allowing a child seat with "Semi-universal or vehicle-specific" approval to be attached using the ISOFIX system on equipped vehicles; check that it can be fitted.

i-U = Suitable for "Universal" front-facing and rear-facing i-Size restraint devices.

i-UF = Suitable only for "universal" front-facing and rear-facing i-Size restraint devices.

(1) Move the vehicle seat backwards as far as possible and lower it as much as possible, then tilt the seatback slightly (by approximately 25°).

(2) If necessary, position the vehicle seat as far back as possible. In order to install a rear-facing child seat, move the front seat as far forward as possible, then move the front seat back as far as it will go, without allowing it to come into contact with the child seat.

(3) Always retract the headrest of the rear seat on which the child seat is positioned. This action must be performed before fitting the child seat → **52**. Move the seat in front of the child forwards, move the seatback forward to avoid contact between the seat and the child's legs.

(4) Raise the seat to the maximum and position it as far back as possible, tilting the seatback slightly (approximately 25°). The child seat must not be in contact with the centre console or the dashboard.

The size of the ISOFIX child seat is indicated by a letter:

CHILD SEATS

- F3,F2,F2X [A, B, B1]: for forward-facing seats in group 1 (9 to 18 kg);
- B2, B3: boosters in groups 2 and 3 (15 to 25 kg and 22 to 36 kg);
- R3, R2 [C, D]: rear-facing seats or shell seats in group 0+ (less than 13 kg) or group 1 (9 to 18 kg);
- R1 [E]: rear-facing shell seats in group 0 (less than 10 kg) or 0+ (less than 13 kg);
- L1,L2 [F, G]: carrycots in group 0 (under 10 kg).



(5) RISK OF DEATH OR SERIOUS INJURY: before fitting a rear-facing child seat to the front passenger seat, check that the airbag has been deactivated → 92.

CHILD SEATS

Fitting diagram

Version with front passenger seat not equipped with the ISOFIX

2

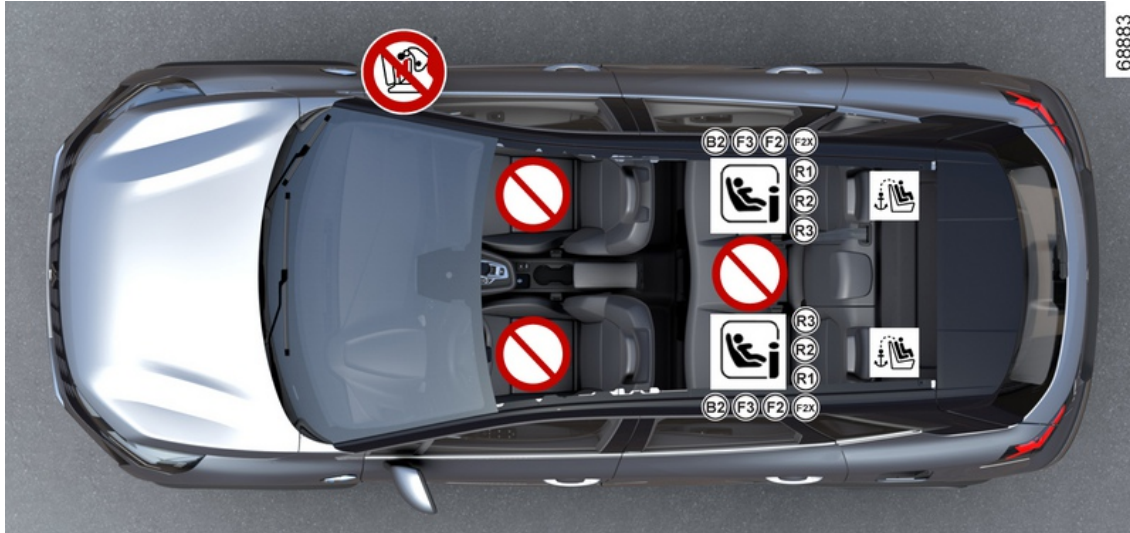

CHILD SEATS

2

 For the front passenger seat, the use of a child seat with a floor support is recommended to avoid triggering the seat belt warning signal.



Using a child safety system which is not approved for this vehicle will not properly protect the baby or child. They risk serious or even fatal injury.



Seat which does not allow a child seat to be fitted.

Child seat attached using the **ISOFIX** system



Seat equipped for attaching a ISOFIX or i-Size child seat.



The front and rear seats are equipped with an anchorage point allowing an ISOFIX universal forward-facing child seat to be attached. The anchoring points are located on the passenger seatback for the front seat and on the bench seatback for the rear seats.



Fit the child seat in a rear seat wherever possible.
To install an ISOFIX seat in this seat, unbuckle the seat belt by hand before engaging the bolts.



Fitting a seat ISOFIX in the rear-left seat means the middle seat cannot be used. The central seat belt will no longer be either accessible or useable.

CHILD SEATS

Installation table

Version with front passenger seat not equipped with the ISOFIX

The table below summarises the information shown on the installation diagram in order to ensure the regulations in force are respected.

Type of child seat	Weight of the child	Size of seat [fix- ture]	Front passen- ger seat	Rear side seats	Rear centre seat
Carrycot fitted across the vehicle Group 0	< 10 kg	L1 [F] L2 [G]	X	X	X
Rear-facing shell seat Groups 0 or 0 +	< 13 kg	R1 [E]	X	IL (1)	X
Rear-facing seat Groups 0+ and 1	< to 13 kg and 9 to 18 kg	R3 [C] R2 [D]	X	IL (1)	X
Forward-facing seat Group 1	9 to 18 kg	F3 [A] F2 [B] F2X [B1]	X	IUF - IL (1)(2)	X
Booster seat Groups 2 and 3	15 to 25 kg and 22 to 36 kg	B2	X	IUF - IL (1) (2)	X
		B3	X	X	X
Seati-Size	Rear-facing seat		X	i - U (1)	X
	Forward-facing seat		X	i - UF (1) (2)	X
	Booster seat		X	i - UF (1) (2)	X

X = Seat not suitable for fitting child seats.

CHILD SEATS

IUF = Seat allowing a child seat with "Universal or vehicle-specific" approval to be attached using the ISOFIX system on equipped vehicles; check that it can be fitted.

IL = Seat allowing a child seat with "Semi-universal or vehicle-specific" approval to be attached using the ISOFIX system on equipped vehicles; check that it can be fitted.

i-U = Suitable for "Universal" front-facing and rear-facing i-Size restraint devices.

i-UF = Suitable only for "universal" front-facing and rear-facing i-Size restraint devices.

(1) If necessary, position the vehicle seat as far back as possible. In order to install a rear-facing child seat, move the front seat as far forward as possible, then move the front seat back as far as it will go, without allowing it to come into contact with the child seat.

(2) Always retract the headrest of the rear seat on which the child seat is positioned. This action must be performed before fitting the child seat → **52**. Move the seat in front of the child forwards, move the seatback forward to avoid contact between the seat and the child's legs.

The size of the ISOFIX child seat is indicated by a letter:

- F3, F2, F2X [A, B, B1]: for forward-facing seats in group 1 (9 to 18 kg);
- B2, B3: boosters in groups 2 and 3 (15 to 25 kg and 22 to 36 kg);
- R3, R2 [C, D]: rear-facing seats or shell seats in group 0+ (less than 13 kg) or group 1 (9 to 18 kg);
- R1 [E]: rear-facing shell seats in group 0 (less than 10 kg) or 0+ (less than 13 kg);
- L1, L2 [F, G]: carrycots in group 0 (under 10 kg).

CHILD SAFETY: DEACTIVATING, ACTIVATING THE FRONT PASSENGER AIRBAG

Warning



The passenger airbag may only be activated or deactivated while the **vehicle is stationary and the ignition is switched off.**

Front passenger airbag deactivation

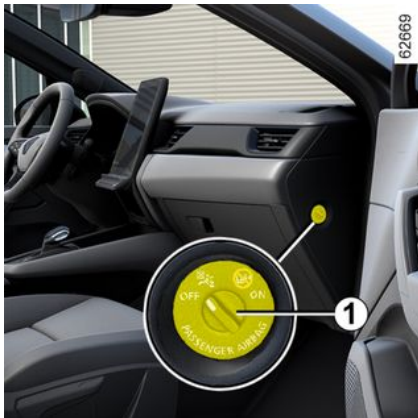

Before installing a child seat on the front passenger seat:

- check that the child seat can be installed on this seat;

- you **must** deactivate the airbag when using a rear-facing child seat.



To deactivate the airbag: with the vehicle stationary and the ignition switched off, push and turn the lock 1 to the OFF position.

When the ignition is switched on, you

must check that the  warning light is illuminated on the display 2.

This light remains continuously lit to let you know that you can fit a child seat.



DANGER

As the operation of the front passenger airbag is not compatible with the positioning of rear-facing child seat, **NEVER** fit a rear-facing child restraint system in a seat protected by an **ACTIVATED** front **AIRBAG**. This could lead to the **CHILD'S DEATH** or **SERIOUS INJURY**.



CHILD SAFETY: DEACTIVATING, ACTIVATING THE FRONT PASSENGER AIRBAG



The markings on the dashboard and the labels **A** on each side of the passenger sun visor **3** (see example of label above) are provided to remind you of these instructions.

Activation of the front passenger airbag

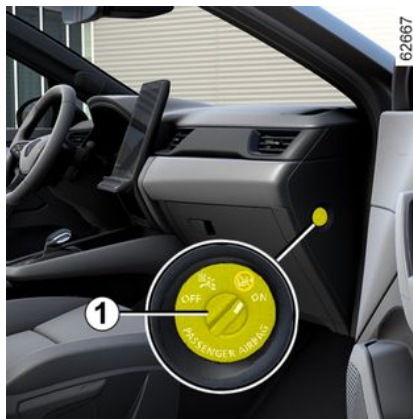



You must reactivate the airbag as soon as you remove the child seat from the front passenger seat to ensure the protection of the front passenger in the event of an impact.



To reactivate the airbag: with the vehicle stationary and the ignition switched off, press and turn the lock **1 to the ON position.**

When the ignition is switched on, you

must check that the  warning



light is off and that the  warning light lights up on the display **2** after each start-up for around 1 minute.

The front passenger airbag is activated.

Operating faults

In the event of a fault with the front passenger airbag activation/deactiva-

CHILD SAFETY: DEACTIVATING, ACTIVATING THE FRONT PASSENGER AIRBAG

tion system, the  and  warning lights are displayed on the instrument panel. Switch off the ignition and check the position of the lock **1**.

Switch the ignition back on: the warning lights go out.

If the problem persists, it signals a system failure. In this case, it is prohibited for a rear-facing child seat to be fitted to the front passenger seat or for any other passenger to occupy the seat.

Contact your approved Dealer as soon as possible;

2

DRIVING POSITION

Driving position: left-hand drive

2

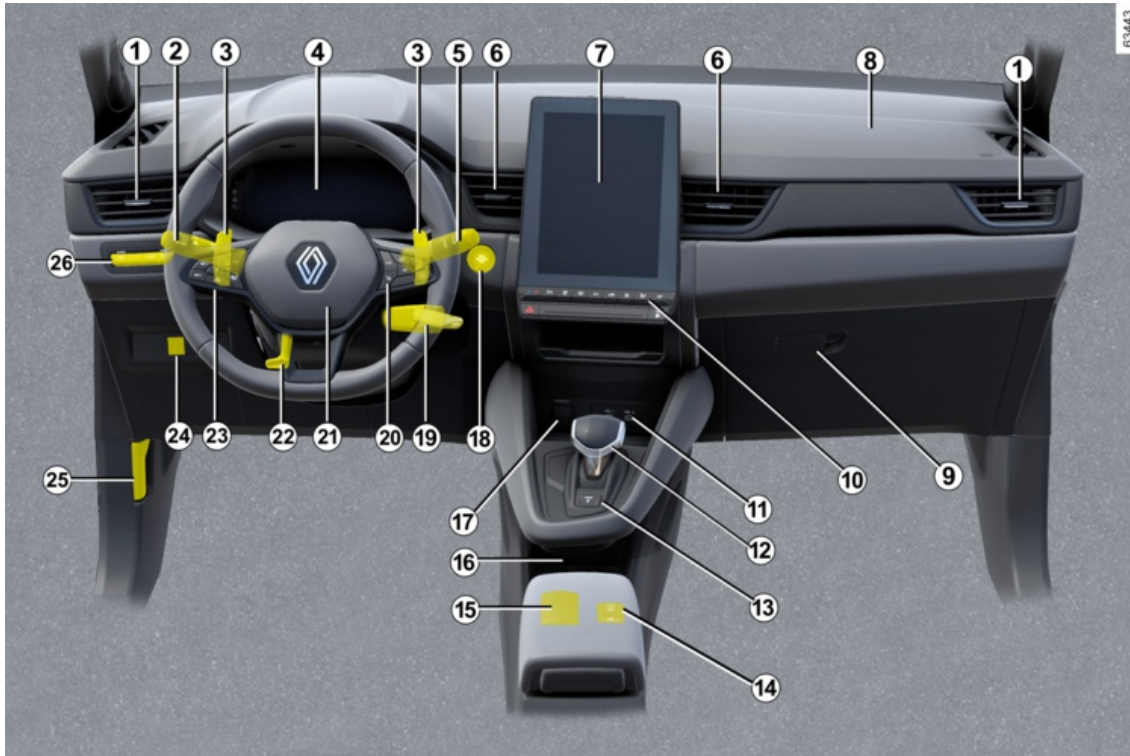

DRIVING POSITION

The fittings described below DEPEND ON THE VEHICLE VERSION AND COUNTRY.

1. Side air vents.

2. Stalk for:

- direction indicator lights;
- exterior lights;
- rear fog lights.

3. Automatic gearbox paddles

4. Instrument panel.

5. Steering column stalk for wind-screen and rear screen wash/wiper.

6. Centre air vents.

7. Multimedia screen.

8. Location of the airbag passenger.

9. Glovebox

10. Controls for:

- heating or air conditioning;
- hazard warning lights;
- door central locking;
- ...

11. USB ports.

12. Gearstick.

13. Parking position button on the automatic gearbox.

14. Controls for:

- activating/deactivating the electronic parking brake;
- activating/deactivating the autohold function.

15. "Hands-free" card holder.

16. Charging zone/telephone storage

17. Accessories socket.

18. Engine start/stop button.

19. Multimedia steering column control.

20. Controls for:

- trip computer information read-out and vehicle settings customisation menu;
- remote radio and navigation system.

21. Driver airbag and horn location.

22. Control for adjusting steering wheel height and reach.

23. Main switch and controls for the Cruise control/Speed limiter/Adaptive cruise control Stop and Go and the Active driver assist.

24. Control for opening/closing the motorised tailgate.

25. Bonnet release control.

26. Controls for:

- the "My Safety" function

- "E-Save" charging level preservation
- lighting dimmer for control instruments;
- electric headlight beam adjustment;
- activating/deactivating "ECO" mode.

DRIVING POSITION

Driver's position, right-hand drive

2

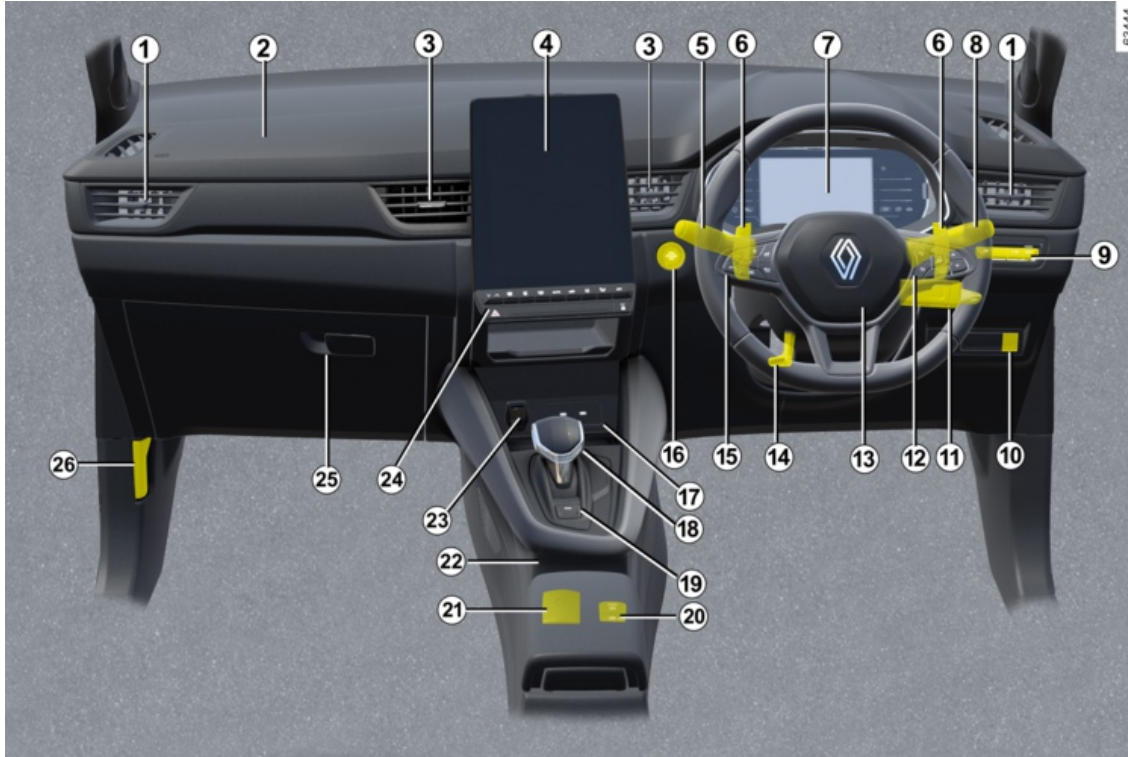

DRIVING POSITION

The fittings described below DEPEND ON THE VEHICLE VERSION AND COUNTRY.

1. Side air vents.

2. Location of the airbag passenger.

3. Centre air vents.

4. Multimedia screen.

5. Stalk for:

- direction indicator lights;
- exterior lights;
- rear fog lights.

6. Automatic gearbox paddles

7. Instrument panel.

8. Steering column stalk for wind-screen and rear screen wash/wiper.

9. Controls for:

- the "My Safety" function
- "E-Save" charging level preservation
- lighting dimmer for control instruments;
- electric headlight beam adjustment;
- activating/deactivating "ECO" mode.

10 Control for opening/closing the motorised tailgate.

11. Multimedia steering column control.

12. Controls for:

- trip computer information read-out and vehicle settings customisation menu;
- remote radio and navigation system.

13. Driver airbag and horn location.

14. Control for adjusting steering wheel height and reach.

15. Main switch and controls for Stop and Go adaptive cruise control/cruise control/speed limiter/Active driver assist.

16. Engine start/stop button.

17. USB ports.

18. Gearstick.

19. Parking position button on the automatic gearbox.

20. Controls for:

- activating/deactivating the electronic parking brake;
- activating/deactivating the autohold function.

21. "Hands-free" card holder.

22. Charging zone/telephone storage

23. Accessories socket.

24. Controls for:

- heating or air conditioning;
- hazard warning lights;

- door central locking;
- ...

25. Glovebox

26. Bonnet release control.

TRIP COMPUTER

General information

2 Trip computer A or B

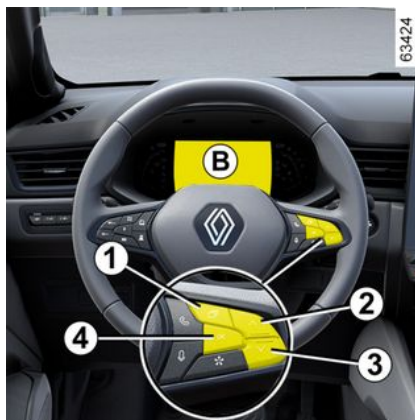

Depending on the vehicle, this includes the following functions:

- mileage;
- trip settings;
- information messages;
- operating fault messages (related to

the  warning light);

- warning messages (related to the

 warning light);

- vehicle settings customisation menu
→ 112.

All of these functions are detailed in this user manual.

Vehicle fitted with instrument panel A



The functions are displayed in zone **5**

Select the functions by repeatedly pressing switch **2** or **3**.

TRIP COMPUTER

Vehicle fitted with instrument panel **B**

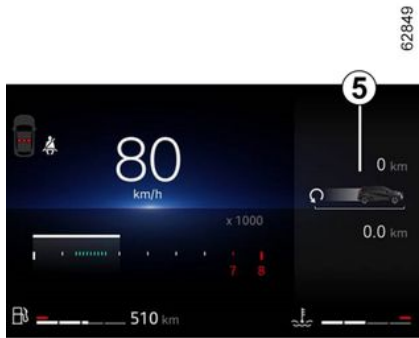

The functions are displayed in zones **5**.

Select the functions by repeatedly pressing switch **2** or **3**.

Selections

(the display depends on the vehicle equipment and country)

- f) Trip log, operating fault and information message readout;
- b) Trip settings:
 - average consumption;
 - current fuel consumption;
 - estimated mileage with remaining fuel;

- mileage;
- average speed;
- c) trip mileage recorder and average speed;
- d) reset the tyre pressures;
- e) set the time;
- f) mileage before service:
 - distance before service;
 - mileage before oil change.

Resetting the trip mileage recorder and journey parameters (reset button)

With one of the trip settings selected as the display, press and hold switch **4** "OK " until the display resets to zero.

Automatic resetting of the journey parameters

Resetting occurs automatically when the maximum value of any of the parameters is exceeded.

Interpreting some of the values displayed after resetting

The values showing average fuel consumption, range and average speed will become more stable and reliable the further you travel after pressing the reset button.

For the first few miles after pressing the reset key you will notice that the

range increases as you travel. This range takes into account the average fuel consumption since the last time the reset button was pressed. Therefore, the average fuel consumption may decrease when:



- the vehicle stops accelerating;
- the engine reaches its operating temperature (if the engine was cold when the reset key was pressed);
- when driving from an urban area on to the open road.

TRIP COMPUTER

Journey settings

2

The display of information shown below **DEPENDS ON THE VEHICLE EQUIPMENT AND COUNTRY.**

Examples of selections	Interpreting the display selected
No stored message	a) Trip log. Successive display: <ul style="list-style-type: none">– information messages (passenger airbag OFF etc.);– operating fault messages (check the injection system, etc.).
 7.4 L/100	b) Current fuel consumption. This value is displayed after a speed of approximately 19 mph (30 km/h) is reached. Average fuel consumption since the last reset. The value is displayed after having travelled at least 400 metres since the last reset. c) Trip mileage recorder: distance travelled since the last reset.
 5.8 L/100	
 112,4 km	
Reset tyre pressure, press and hold	d) Reset the tyre pressures → 163.
16 :30	e) Set the time. → 114

TRIP COMPUTER

<p>Examples of selections</p>	
<p>On-board computer with mileage-before-service message</p>	<p>Interpreting the display selected</p>
<p>Service in 18,641 miles (30,000 km)/12 months</p>	<p>d) Mileage before service and oil change. Service distance With the ignition on and the engine not running, access the "Mileage before service" information. When the distance or time value approaches its limit, there are several possible scenarios:</p>
<p>Service due in less than 186 miles (300 km) or 24 days</p>	<p>– mileage remaining less than 932 miles (1,500 km) or one month: the "Service due in" message is displayed accompanied by the nearest limit (distance or time); – range equal to 0 miles (0 km) or date of service reached: the message "Ser-</p>
<p>Service vehicle</p>	<p>vice required" is displayed accompanied by the warning light  . The vehicle requires a service as soon as possible.</p>
<p>Resetting: to reset the mileage before the next service, press and hold the OK button for approximately 10 seconds until the display shows the mileage before service permanently.</p>	
<p>Note: if a service is performed without changing the engine oil, only the mileage before the next service should be reset. In the event of an oil change, both the distance before the next service and the next oil change should be reset.</p>	
<p>Oil change in 18,641 miles (30,000 km)/24 months</p>	<p>Mileage before oil change With the ignition on and the engine not running, access the "Mileage before service" information to display the mileage before the next oil change.</p>
<p>Depending on the vehicle, the mileage before an oil change varies according to the driving style (frequent driving at low speed, door-to-door journeys, extensive use at idling speed, towing a trailer, etc.). The distance remaining until the next oil change can therefore decrease more quickly in some cases than the actual distance travelled.</p>	
<p>Reset: to reset the distance before the next service, press and hold button OK for approximately 10 seconds until the display shows the mileage before oil change permanently.</p>	
<p>Note: if a service is performed without changing the engine oil, only the mileage before the next service should be reset. In the event of an oil change, both the distance before the next service and the next oil change should be reset.</p>	

TRIP COMPUTER

Information messages

These can help in the vehicle starting phase, or give information about a selection or a driving status.

Examples of information messages are given in the following pages.

Examples of messages	Interpreting the display selected
"Parking brake applied"	Indicates that the parking brake has been applied.
"Turn steering wheel + START"	Turn the steering wheel slightly whilst pressing the vehicle start button to unlock the steering column.
"Checking control functions"	Displayed with the ignition on when the vehicle is running self-diagnostics.

TRIP COMPUTER

Operating fault messages

These appear with the  warning light to inform you that you should drive very carefully to an approved dealer as soon as possible. If you fail to follow this recommendation, you risk damaging your vehicle.

They disappear when the display selection key is pressed or after several seconds and are stored in the computer log. The



warning light stays on. Examples of operating fault messages are given in the following pages.

Examples of messages	Interpreting the display selected
"Check vehicle"	Indicates a fault in one of the pedal sensors, battery management system or oil level sensor.
"Check airbag"	Indicates a fault in the restraint system in addition to the seat belts. In the event of an accident, it is possible that they may not be triggered.
"Check emission control"	Indicates a fault in the vehicle's particle filter system.
"Check electrical system"	Indicates a fault in the traction system.

TRIP COMPUTER

Warning messages

2

These appear with the **STOP** warning light and require you to stop immediately, for your own safety, as soon as traffic conditions allow. Stop your engine and do not restart it. Call an approved Dealer.

Some examples of warning messages are given below. **Note:** the messages appear on the display either individually or alternately (when there are several messages to be displayed), and may be accompanied by a warning light and/or a beep.

Examples of messages	Interpreting the display selected
"Risk of engine failure"	Indicates an injection fault, the vehicle's engine has overheated or there is a serious engine fault.
"Braking system fault"	Indicates a fault in the braking system.
"DANGER electrical fault"	Indicates a fault in the electrical system or a problem in the vehicle battery charging circuit (alternator, etc.).
"Puncture"	Indicates that at least one wheel is punctured or severely underinflated.
"Steering fault"	Indicates a problem with the steering.
"Electric engine fault"	Indicates that the vehicle is losing power.

TRIP COMPUTER

Displays and indicators

Instrument panel A



It lights up when the ignition is switched on. In some cases, the appearance of a warning light is accompanied by a message.

Depending on the vehicle, you can customise your instrument panel with the content and colours of your choice. Please refer to the multimedia instructions for more information.

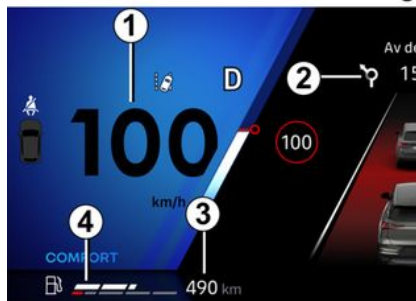

Speedometer 1

Multimedia information 2

Depending on the vehicle, you can display information from the multimedia screen (compass, telephone, navigation, etc.) or information from the trip computer.

Please refer to the multimedia instructions for more information.

Estimated range with remaining fuel 3

The value is displayed after driving 400 metres → 100.

Fuel gauge 4

If the level is at the minimum, warning

light  integrated in the indicator comes on orange, accompanied by a beep. Fill up as soon as possible.

Trip computer 5

→ 100

Rev counter 6

(scale x 1,000)

Depending on the selected customisation, it may not be displayed.

TRIP COMPUTER

Coolant temperature indicator **8**

In normal use, the indicator **8** should be located before zone **7**.

Under "intensive" operating conditions, the needle may approach this zone.

This is not serious unless the warning

light **STOP** comes on accompanied by a message on the instrument panel and a beep.

Instrument panel **B**



It lights up when the ignition is switched on.

In some cases, the appearance of a warning light is accompanied by a message.

Depending on the vehicle, you can customise your instrument panel with the content and colours of your choice.

For more information, refer to the equipment instructions.

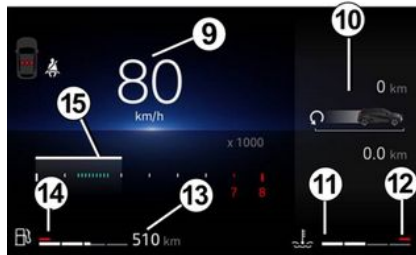

Speedometer **9**

Depending on the style selected, the display varies.

Rev counter **15**

(scale x 1,000)

This is displayed differently according to how the instrument panel is customised. Depending on the style selected, it may not be displayed.

Trip computer/Multimedia information **10**

Depending on the vehicle, you can display information from the multimedia screen (compass, telephone, navigation, etc.) or information from the trip computer.

Please refer to the multimedia instructions for more information.

Coolant temperature indicator **11**

In normal use, the indicator **11** should be located before zone **12**.

Under "intensive" operating conditions, the needle may approach this zone.

This is not serious unless the warning

light **STOP** comes on accompanied by a message on the instrument panel and a beep.

Estimated range with remaining fuel **13**

The value is displayed after driving 400 metres → **102**.

Fuel gauge **14**

If the level is at the minimum, the warning light integrated into the indicator appears in orange, accompanied by a beep.

TRIP COMPUTER

Fill up as soon as possible.

64040



Direction indicators **16** and **20**

Warning light **17**

→ 115

Tyre under-inflation warning light **18**

→ 163

Airbag warning light **19**

→ 60

Electronic parking brake warning light **21**

→ 150

"Hands off steering wheel" detection warning light **22**

→ 172 → 209

Urgent stop warning light **23**

→ 115

64041



Special features of E-Tech Full Hybrid versions

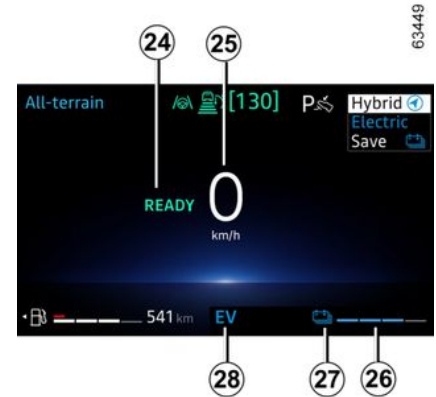

63449

2

It lights up when the ignition is switched on.

In some cases, the appearance of a warning light is accompanied by a message.

Message indicating that the vehicle is ready for driving **24**

The READY message appears when the ignition is switched-on and disappears when the vehicle speed exceeds 3 mph (5 km/h).

TRIP COMPUTER

Speedometer 25

Depending on the style selected, the display varies.

"230 V" traction battery level remaining 26

Traction battery level low

In the event of extreme use at low speed, the traction battery charge level may reach a low level.

The warning light 27 is displayed in yellow to warn you.

The electric engine performance will be limited to ensure that the E-Tech Full hybrid system is working correctly until the traction battery charging level is sufficient.

Opt for a smoother driving style or, if possible, stop the vehicle without switching off the ignition until the warning light 27 appears in blue once again.

Immobilisation threshold imminent

In the event of extreme and prolonged use of the vehicle (e.g. towing or driving in steep off-road conditions) at speeds below 6 mph (10 km/h), the charge level may reach the threshold for imminent immobilisation.

A beep sounds and the warning light



appears in red.

If the charge level continues to drop, the electric range value will no longer be displayed.

If possible, stop the vehicle when traffic conditions allow it.

Leave the combustion engine on until the warning lights disappear.

This must be done to recharge the traction battery.

Electric operating mode warning light 28

It is displayed when only the traction battery is powering movement of the vehicle.



Energy flow indicator 29

→ 22

Charge meter 30

→ 157

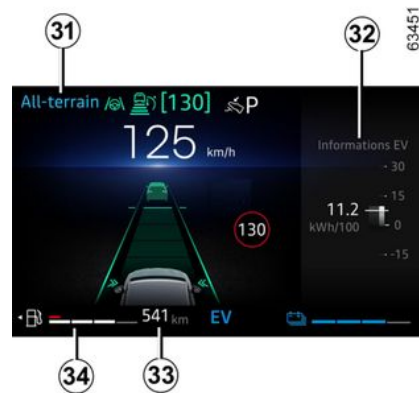

Driving mode selected 31

→ 283

Trip computer zone or Multimedia information zone 32

Estimated range with remaining fuel 33

The value is displayed after driving 400 metres → 102.

TRIP COMPUTER

Fuel gauge 34

If the level is at the minimum, warning

light  integrated in the indicator comes on orange, accompanied by a beep.

Whatever the remaining battery level, fill the tank as soon as possible.

If the vehicle runs completely out of fuel, fill the tank with at least 1.76 gal (8 litres) of fuel.

Otherwise the hybrid mode will remain unavailable.

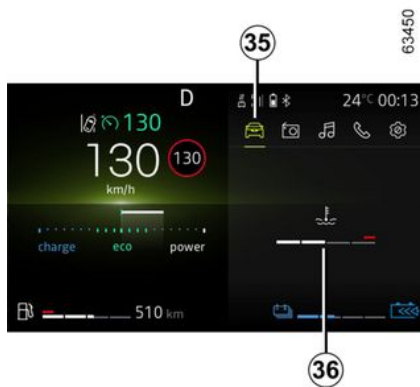

Combustion engine temperature display 36



Press switch **37** to access the "Vehicle" world **35**, then press switch **38** or **39** repeatedly until display **36** is shown.

Engine oil level low warning



When the engine is started, the instrument panel display alerts you when the minimum oil level is reached → **309**.

The first time the warning appears, it can be cleared by pressing switch **40** "OK".

Subsequent warnings will disappear automatically after around 30 seconds.

TRIP COMPUTER

Instrument panel in miles



(option to switch to km/h)

With the vehicle stationary and the engine on, from the multimedia screen **41** select the "Vehicle" world, press the "Settings" menu, then "Units" followed by "Speed".

Choose between km/h or mph.

The speedometer and some of the distance information displayed on the instrument panel are converted.

To return to the previous mode, repeat the same operation.

Note: once the battery is switched off, the trip computer automatically returns to the original unit of measurement.

Please refer to the multimedia instructions for more information.



To use certain driving aid functions, it is necessary to change the unit of measurement on the instrument panel in order to obtain the appropriate information when driving in a country where the speed units differ from those set as default on your vehicle.



For safety reasons, carry out any adjustments while the vehicle is stationary.

Vehicle settings personalisation menu

Depending on the vehicle equipment, this function allows you to activate/deactivate and adjust some of the vehicle's functions.

From the multimedia screen 1



Accessing the settings menu

Refer to the various multimedia instructions for information on accessing the settings.

Adjusting the settings

Select a menu then the function to be modified (the display depends on the vehicle equipment and country):

- a) "Driving":
 - Direction indicator volume;
- b) "Access":
 - Release driver's door;
 - Lock doors during driving;
 - Opening/closing in hands-free mode;

TRIP COMPUTER

- Remote locking/approach unlocking;
- Remote locking sound;
- Silent mode;
- Automatic locking;

c) "Wiping and lighting":

- Wiping in reverse;
- Automatic front wiping;
- Wipe after wash;

d) "Welcome":

- Exterior welcome;
- Automatic deployment of door mirrors;
- Interior welcome;
- Courtesy light auto mode

Depending on the function, select:

- "ON" or "OFF" to activate or deactivate it,

or

- a setting for the time the lights are switched on (e.g. for the "Follow-me-home lighting" function).

Please refer to the multimedia instructions for further information.



For safety reasons, carry out any adjustments while the vehicle is stationary.

On the instrument panel

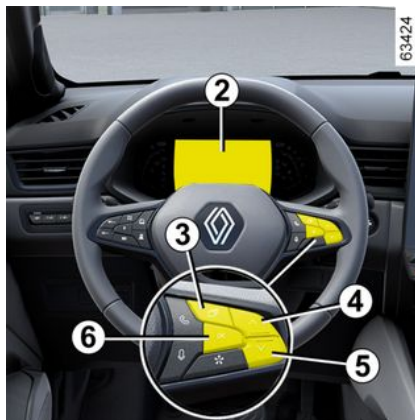

Accessing the settings menu on the display 2

Press switch **3** as many times as required to reach the "Settings" world, then confirm by pressing switch **6** "OK".

Press control **4** or **5** repeatedly to reach the "Vehicle settings" menu, then confirm by pressing "OK".

Use control **4** or **5** to browse and select the function to be modified, then confirm by pressing "OK" (the display may vary according to the vehicle equipment and the country):

"INSTRUMENT PANEL":

- Language;
- Unit;
- Style;
- Colour.

"VEHICLE":

- Rear windscreen wiping in reverse gear;
- Automatic windscreen wiping;
- Wipe after wash;
- Direction indicator volume;
- Exterior welcome.

"PARKING AIDS":

- Front;
- Rear;
- Side;
- Beep volume.

"DRIVING AIDS":

- Lane departure warning sound volume;
- Lane departure warning sensitivity;
- Lane departure warning vibration;
- Lane Keep Assist sensitivity;
- Blind spot;
- Active braking;
- Speed warning;
- Fatigue warning;
- Distance warning.

"LIGHTING":

- Courtesy light auto mode;
- Automatic follow-me-home lighting;
- Follow-me-home lighting: XX seconds;
- ...

TRIP COMPUTER

"ACCESS":

- Lock doors during driving;
- Hands-free opening/closing;
- Unlocking the driver's door only;
- Automatic re-locking;
- Unlocking when approaching;
- Locking when moving away;
- Silent locking;
- Automatic opening/closing;
- Automatic deployment of door mirrors;
- ...

"RESETTING".



function activated;



function deactivated.

Press switch **3** to return to the previous menu.

If you select "PARKING AIDS" or "INSTRUMENT PANEL", you will be able to make a selection (Park Assist sound volume or instrument panel language).

In this case, make your selection and confirm it by pressing the switch **6** "OK", the selected value is shown by a



in front of the line.

To exit the menu, press the switch **3**.

It may be necessary to carry out this operation more than once.



The vehicle settings personalisation menu cannot be used when driving.

At a speed exceeding 12 mph (20 km/h), the instrument panel display switches automatically back to trip computer and warning system mode.

Clock and outdoor temperature

From the multimedia screen

The time and outdoor temperature are displayed on the multimedia screen **1**.

Refer to the multimedia instructions.

Exterior temperature indicator

Special feature:

When the exterior temperature is between -3°C and $+3^{\circ}\text{C}$, the $^{\circ}\text{C}$ characters flash to signal a risk of ice on the road.



Exterior temperature indicator

As ice formation is related to climatic exposure, local air humidity and temperature, the external temperature alone is not sufficient to detect ice.



Depending on the vehicle, if the electrical supply is cut (battery disconnected, supply wiring broken, etc.), the clock will automatically revert to the correct time after a few minutes once the system is able to receive GPS information.

WARNING LIGHTS

The display of information shown below **DEPENDS ON THE VEHICLE EQUIPMENT AND COUNTRY.**



Instrument panel A or B: it illuminates when the ignition is switched on. To adjust the brightness, see the multimedia user manual.

In some cases, the appearance of a warning light is accompanied by a message on the instrument panel.



Warning light 

means you should drive **very carefully to an authorised dealer as soon as possible.** If you fail to follow this recommendation, you risk damaging your vehicle.



If the **STOP** warning light appears, for your safety you must stop the vehicle as soon as traffic conditions allow. Switch off the engine and do not restart it. Call an approved dealer.



If no lights or sounds are apparent, this indicates a fault in the instrument panel. This indicates that it is essential to stop immediately (as soon as traffic conditions allow). Ensure that the vehicle is correctly immobilised and contact an approved Dealer.



Side light tell-tale light



Main beam headlight tell-tale light



Dipped beam headlight tell-tale light



Rear fog lights tell-tale



Automatic main beam headlight warning light → 124



Left-hand direction indicator tell-tale light



Right-hand direction indicator tell-tale light

WARNING LIGHTS



Tell-tale light for airbag

It lights up when the ignition or the engine is switched on and goes off after a few seconds.

If it does not light up when the ignition is switched on, or if it lights up when the engine is running, this indicates a fault in the system.

Contact your approved Dealer as soon as possible;

STOP Urgent stop warning light

This lights up when the ignition or engine is switched on and goes out as soon as the engine is running. It comes on with other warning lights and/or messages, and is accompanied by a beep.

For your own safety, it requires you to stop immediately, as soon as traffic conditions allow. Switch off the engine and do not restart it.

Call an approved dealer.



Brake circuit fault warning light

It lights up when the ignition or the engine is switched on and goes off after a few seconds.

If it comes on during braking and is ac-

companied by the **STOP** warning light and a beep, it indicates that the

fluid level in the circuit is low or that there is a braking system fault. Stop as soon as traffic conditions allow and consult an approved Dealer.



Battery charge warning light

It lights up when the ignition or the engine is switched on and goes off after a few seconds.

If it comes on on the road, accompa-

nied by the **STOP** warning light and a beep, this indicates an overload or discharge in the electrical circuit. Stop as soon as traffic conditions allow and consult an approved Dealer.



Oil pressure warning light

It lights up when the ignition or the engine is switched on and goes off after a few seconds.

If it comes on on the road, accompa-

nied by the **STOP** warning light and a beep, stop immediately and cut the ignition.

Check the oil level. If the level is normal, the warning light is related to something else.

Call an approved dealer.



Variable power assisted steering warning light

It lights up when the ignition or the en-

gine is switched on and goes off after a few seconds.

If it comes on while driving, alongside

the warning light **STOP**, this means there is a system fault. Call an approved dealer.



"AUTOHOLD" system warning light → 153



Warning light

This lights up when the ignition or engine is switched on and goes out as soon as the engine is running. It can light up in conjunction with other warning lights and/or messages on the instrument panel. It means you should **drive very care- fully** to an approved Dealer as soon as possible. If you fail to follow this recommendation, you risk damaging your vehicle.



Warning light

If it appears in red during driving and is

accompanied by the **STOP** indicator light, you must, for your safety, stop as soon as traffic conditions allow. Switch off the engine and do not restart it. Call an approved dealer. If it appears in yellow during driving and is accompanied

by the  warning light, visit an

WARNING LIGHTS

approved dealer as soon as possible.

Meanwhile, drive with care.

If you fail to follow this recommendation, you risk damaging your vehicle.

 **Electronic parking brake applied warning light** → 150

 **Warning light for the electronic stability program (ESC) and traction control system**

It lights up when the ignition or the engine is switched on and goes off after a few seconds.

The → 167 warning light may appear for several reasons.

 **Warning light for non-availability of the electronic stability program (ESC) and traction control system**

 **Anti-lock braking warning light**

It lights up when the ignition or the engine is switched on and goes off after a few seconds.

If it comes on when you are driving, it indicates a fault on the antilock braking system.

Braking will then be as normal, without the ABS. Contact your approved Dealer straight away.

 **Particle filter system warning light** → 148

 **Tyre under-inflation warning light**

This lights up when the ignition is switched on or when the engine starts, then disappears after a few seconds → 163.

 **Toxic fume filter system warning light**

On equipped vehicles, the light comes on when the engine is started and then goes out.

- If it lights up continuously, contact an approved Dealer as soon as possible;
- If it flashes, reduce the engine speed until the light stops flashing. Contact an approved dealer as soon as possible → 156.

 **Low fuel level warning light**

It lights up orange when the ignition or the engine is switched on and goes off after a few seconds.

If the light becomes orange while driving and a beep sounds, fill up with fuel as soon as possible. There is only approximately 31 miles (50 km) worth of fuel left.

 **Mode warning light ECO**

This lights up when ECO mode is activated → 157.

 **Coolant temperature warning light**

This lights up blue when you switch on the ignition or start the engine.

If it turns red, stop and let the engine idle for a minute or two.

The temperature should lower and the warning light should return to a blue colour. Otherwise, stop the engine. Let the engine cool down before checking the coolant.

Call an approved dealer.

 **Speed limiter warning light** → 226

 **Cruise control warning light** → 230

 **Adaptive cruise control warning light** → 234

 **Lane centring system warning light** → 209

 **Brake pedal warning light**

This lights up when the brake pedal should be pressed → 143.

WARNING LIGHTS



Hands-free parking warning light → 261



Lane departure prevention warning light → 172



Warning light of the "Active emergency braking" function → 195



Warning light to indicate a fault or non-availability of active emergency braking → 195



"Hands off steering wheel" detection warning light → 172



"Driver vigilance warning" function fault warning light → 202
It lights up to signal a fault with the driver vigilance warning. Contact your approved Dealer straight away.



Electrotechnical system warning light

It lights up along with the warning light

STOP and a beep when the electrical assembly temperature is too high. Stop the vehicle and switch off the ignition. Consult an approved Dealer.
If it lights up accompanied by the

STOP warning light, a beep and the "EVACUATE IN SAFETY" message, switch off the ignition and do not restart the engine. Leave the vehicle and consult an approved dealer.



The "EVACUATE IN SAFETY" message accompanied by the

STOP warning light and a beep indicates that for your safety you must stop the vehicle immediately, depending on the traffic conditions. Switch off the ignition. Leave it switched off. Exit the vehicle, get all passengers out of the vehicle and keep them away from the vehicle and traffic.
Fire hazards



If the vehicle is parked on the hard shoulder, you must warn other road users of your vehicle's presence with a warning triangle or with other devices as per the legislation applying to the country you are in.



Secondary 12 V battery charge warning light

If it comes on, accompanied by the

warning light **STOP** and a beep, this means that the electrical circuit is overcharged or discharged → 316.



Traction battery fault warning light

If it appears, accompanied by the



warning light, this indicates a fault related to the operation of the traction battery. Contact your approved Dealer straight away.



Traction battery gauge warning light

This appears in yellow when the traction battery charge level has reached

WARNING LIGHTS

the reserve level → 107.

EV Electric operating mode warning light

It is displayed when only the electric motor and traction battery are powering the movement of the vehicle → 22.

Electrotechnical motor fault warning light

When it comes on, this indicates an electrotechnical fault related to the electrical assembly (traction battery and electric motor). Contact your approved Dealer straight away.

Electric motor fault warning light

When it comes on, this indicates a fault with the electrotechnical system linked to the electric motor. Contact your approved Dealer straight away.

Pedestrian horn fault warning light



On display *C*

 Airbag passenger ON → 92

 Airbag passenger OFF → 92

 Seat belt reminder warning light → 55

STEERING

Adjusting the steering wheel height and depth



Lower the lever **1** and set the steering wheel to the required position.

Then, raise the lever fully, beyond the point of resistance to lock the steering wheel.

Make sure that the steering wheel is correctly locked.



For safety reasons, only adjust the steering wheel when the vehicle is stationary.

Steering wheel heating



(depending on the vehicle)

This function heats the steering wheel **2**.

Operating principle

When the temperature is reached, the function regulates the temperature of the heated areas for approximately 30 minutes and then switches off automatically.

Activating the function

With the ignition on, press the switch **3**, the indicator light built into the switch lights up.

Deactivating the function

- **Automatically:**

The function switches off automatically after the regulation phase of approximately 30 minutes. The indicator light built into the switch **3** stays on.

Note: if the function has switched off automatically, press the switch **3** twice to reactivate it.

If the switch **3** is not pressed again, the function will be reactivated the next time the ignition is switched on.

- **Manually:**

To deactivate the function during the regulation phase, press the switch **3**. The indicator light built into the switch **3** goes out.

Power-assisted steering

Never drive with an inadequately charged battery.

Variable power assisted steering

The variable power-assisted steering system is equipped with an electronic control system which alters the level of assistance to suit the vehicle speed.

Steering is made easier during parking manoeuvres (for added comfort) while the force needed to steer increases progressively as the speed rises (for enhanced safety at high speeds).

STEERING

Special case

Depending on the vehicle, in the event of a battery fault (disconnected, discharged battery, etc.), the steering wheel angle must be reset. To do this:

- the vehicle stationary and on flat ground;
- with only the driver in the vehicle,

start the engine: the  warning light and/or, depending on the vehicle, the "Turn steering wheel fully right and left" message is displayed on the instrument panel;

- turn the steering wheel fully to the left and then to the right, applying force when it arrives at the stop. Switch off the engine and wait for around a minute. When the engine next starts, the warning light and/or, depending on vehicle, the message will disappear.

Note: the power-assisted steering depends on the driving mode selected in the "MULTI-SENSE" menu → **283**.

 With the engine switched off, or if there is a system fault, it is still possible to turn the steering wheel. The force required will be greater.

 Never leave the steering wheel on full lock when the vehicle is stationary.

REAR VIEW MIRRORS

Exterior rear view mirrors

2



Adjustment

When you select the door mirror using the switch **2**, the warning light built into the switch will appear. Then use the button **1** to adjust it to the desired position.

Heated rear view mirrors

Mirror de-icing is carried out at the same time as rear screen de-icing → **285**.

Electrical folding mirrors

The door mirrors will fold-out automatically when the vehicle is unlocked. The door mirrors fold in when the vehicle is locked.

Note: you can deactivate/activate the automatic folding of the door mirrors → **112**.

You can force folding by pressing the switch **3**. In this situation, the door mirrors will remain folded until the **3** button is pressed again, regardless of automatic folding.

Special case

When the rear view mirror has been manually deployed or folded back, it is possible to reset it to a usage position. To do this, press the switch **3**. A mechanical tapping noise can be heard from the door mirror.

If a tapping noise cannot be heard, press the switch **3** again until the tapping noise can be heard from the door mirror.



For safety reasons, carry out any adjustments while the vehicle is stationary.



Objects observed in the rear view mirror glass are actually closer than they appear. For your safety, take this into account in order to correctly assess the distance before any manoeuvre.

Interior rear view mirror

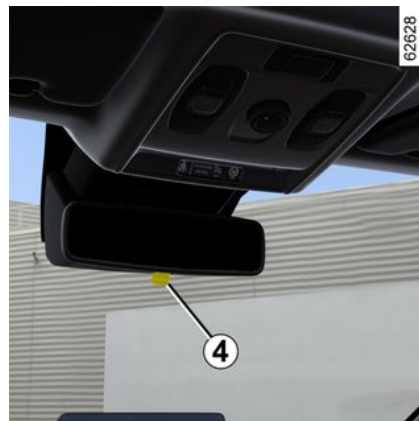

Its position can be adjusted.

Rear view mirror with lever 4

When driving at night, to avoid being dazzled by the headlights of the vehi-

REAR VIEW MIRRORS

cle behind, shift the small lever **4** located behind the rear view mirror.

Rear view mirror without lever **4**

The rear view mirror automatically darkens when you are being followed by a vehicle which illuminates you or in very bright lighting.



For safety reasons, carry out any adjustments while the vehicle is stationary.



Objects observed in the rear view mirror glass are actually closer than they appear. For your safety, take this into account in order to correctly assess the distance before any manoeuvre.

LIGHTING AND SIGNALS

Exterior lighting and signals

2



63498

Side lights

 Turn the ring **2** until the symbol is opposite the mark **3**.

This indicator light on the instrument panel comes on.

Note: depending on the vehicle, the side lights can only be activated manually when the parking brake is applied or, depending on the vehicle, when the gear lever is in the **P** position.

Otherwise, the "Unavailable position lights" message is displayed on the in-

strument panel to inform you that it is not possible to activate the side lights.

Daytime running lights function

The daytime running lights are activated automatically, without any action on the stalk **1**, when the engine is started and they are deactivated when the engine is switched off.

Dipped beam headlights

Manual operation

Turn the ring **2** until the symbol is opposite the mark **3**. This indicator light on the instrument panel comes on.

Automatic operation

(depending on the vehicle)

Rotate the ring **2** until the AUTO symbol is aligned with the mark **3**: with the engine on, the dipped beam headlights switch on or off automatically according to the exterior light level, without any action on the stalk **1**.

Depending on the vehicle, the dipped beam headlights will appear automatically after several sweeps of the wind-screen wiper blades.



Before driving at night, check that the electrical equipment is operating correctly and adjust the headlight beams (if your vehicle is not carrying its normal load)
→ **128**. As a general precaution, check that the lights are not obscured (by dirt, mud, snow or objects being transported).

Main beam headlights



With the engine running and the dipped beam headlights lit, push stalk **1**. This indicator light on the instrument panel comes on.

To return to the dipped beam headlights position, pull the stalk **1** towards you again.

"Raise lights during driving" function

When the main beam headlights are activated, the "Raise lights during driving" function improves driver visibility by automatically raising the dipped beam headlight and the main beam headlights.

LIGHTING AND SIGNALS

During deactivation of the main beam headlights, the dipped beam headlights return to their original position.

Automatic main beam headlights

 Depending on the vehicle, this system switches the main beam headlights on and off automatically. It uses a camera located behind the interior rear view mirror to detect vehicles that are being followed and those coming in the opposite direction.



The system may encounter difficulties under certain conditions, including:

- extreme weather conditions (rain, snow, fog, etc.);
- obstruction in front of the windscreen or camera;
- when a following or oncoming vehicle has weak or hidden lighting;
- incorrect settings for the front headlights;
- reflecting systems;
- ...

The main beam headlights come on automatically if:

- the exterior light level is low;
- no other vehicle or lighting is detected;
- the vehicle speed is above approximately 25 mph (40 km/h).

If any of the above conditions are not fulfilled, the system switches to dipped beam headlights.

Note: make sure the windscreen is not obscured (dirt, mud, snow, condensation, etc.).

To activate the automatic main beam headlights:



63498

rotate the ring **2** until the AUTO symbol is aligned with the mark **3** and

push the stalk **1**. Warning light  comes on the instrument panel.

To deactivate the automatic main beam headlights:

- rotate the ring **2** to a position other than AUTO;
- or
- pull the stalk **1**.

Warning light  goes out on the instrument panel.

Note: the main beam headlights will be activated upon deactivation of the automatic main beam headlights function.

Operating faults

If the "Check automatic lighting" message appears on the instrument panel, the system is deactivated.

Consult an approved dealer.

LIGHTING AND SIGNALS

2



Using a portable navigation system at night in the windscreen area below the camera may disturb the operation of the "automatic main beam headlights" system (risk of reflection on the windscreen).



The "automatic main beam headlights" system should under no circumstances be used to replace the driver's attention and responsibility with regard to vehicle lighting and adapting to light, visibility and traffic conditions.

Switching off the lights



63498

Depending on the vehicle:

- manually move the ring **2** to position 0;
- or
- the lights will go out automatically when the engine is switched off, the driver's door is opened or the vehicle is locked. In this case, the next time the engine is started the lights will be switched back on according to the position of the ring **2**.

Note: if the fog lights are lit, the lights are not switched off automatically.

Lights-on reminder audible alarm

If the lights are on after the engine is switched off, a warning beep sounds when the driver's door is opened to warn you that the lights are still on.

Operating faults

If the "Check lighting" message ap-

pears with the  warning light

and the  warning light flashes on the instrument panel, this indicates a lighting fault.

Consult an approved dealer.

Welcome and goodbye function

(depending on the vehicle)

Once the function is activated, the daytime running lights and the rear side lights will light up automatically upon detection of the card or when the vehicle is unlocked.

They switch off automatically:

- approximately one minute after lighting up;
- when starting the engine, based on the position of the lighting stalk;
- or
- upon locking the vehicle.

LIGHTING AND SIGNALS

Activating/deactivating the function

For activation or deactivation of the external welcome, refer to the multimedia instructions.

Select "ON " or "OFF ".

"See-me-home lighting" function

This function enables you to briefly switch on the side lights and dipped beam headlights (e.g. to provide light when opening a gate).

With the engine and lights switched off and the ring **2** in the AUTO position or, depending on the vehicle, in the 0 position, pull the stalk **1** towards you: the side lights and dipped beam headlights illuminate for approximately 30

seconds along with the  and

 warning lights on the instrument panel.

To increase this duration, you may pull the stalk up to four times (total time restricted to approximately two minutes).

The "Lighting on ___" message followed by the remaining time will appear as confirmation. You can then lock your vehicle.

To switch off the lights before it is done automatically, rotate the ring **2** to any position, then return it to the AUTO po-

sition or, depending on the vehicle, to the 0 position.

Rear fog lights



63498

 Turn centre ring **4** on the stalk until the symbol faces mark **3**, then release it.

Operation of the fog lights depends on the exterior lighting selected, and an indicator light will light up on the instrument panel.

Do not forget to switch off the fog lights when they are no longer needed, to avoid inconveniencing other road users.

Switching off the lights

Rotate the centre ring **4** again to align the mark **3** with the symbol for the fog lights. The corresponding indicator light on the instrument panel goes out. The rear fog lights switch off when the exterior lights are switched off.

 When driving in fog or snow, or when transporting objects which are higher than the roof, the headlights do not come on automatically. The fog lights are controlled by the driver: indicator lights on the instrument panel inform you whether they are on (indicator light on) or off (indicator light off).

LIGHTING AND SIGNALS

Headlight beam adjustment

2



Switch **A** is used to adjust the height of the headlight beams according to the load.

With the dipped beam headlights on, press or raise switch **A** as many times as required to select the required position on the instrument panel.

Note: depending on the vehicle, when the engine is started, the position selected is displayed on the instrument panel for approximately 30 seconds and for five seconds each time switch **A** is pressed.

LIGHTING AND SIGNALS

Table of adjustment position examples

	Examples of positions for adjusting the control A according to the load
Driver alone or with front passenger	0 or 1
All seats occupied	1 or 2
Driver with passengers and luggage (or load) reaching the maximum permissible all-up weight	2 or 3
Driver without passengers and luggage (or load) reaching the maximum permissible all-up weight	3 or 4

The table below gives some examples. In all cases, adjust the control **A** according to the vehicle load so that the road can be seen and other drivers are not dazzled.

AUDIBLE AND VISUAL SIGNALS

Horn



Press the steering wheel boss **A** to sound the horn.

Headlight flasher

To flash the headlights, pull the stalk **1** towards you, then release.

Direction indicators

Move the stalk **1** in the same direction as you want to move the steering wheel.

One-touch mode

Briefly shift the stalk **1** upwards or downwards, not exceeding the point of resistance, then release it: the stalk

will return to its original position and the direction indicator light concerned will flash three times.

Hazard warning lights



 Press switch **2** to activate all four direction indicator lights and side repeaters.

It must only be used in an emergency to warn drivers of other vehicles that you have had to stop in an area where stopping is prohibited or unexpected, or that you are obliged to drive under special conditions.

WIPER

Windscreen washer, wiper

Vehicle fitted with intermittent windscreen wipers

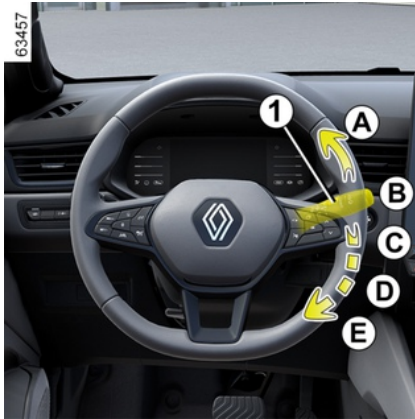

A. a single sweep of the wipers

A short push will trigger one sweep of the wipers.

B. stopping

C. intermittent wiping

The wipers will pause for several seconds between sweeps. It is possible to change the interval between sweeps by turning the ring **2**.

D. slow continuous wiping

E. fast continuous wiping

Special feature

When driving the vehicle, the wiping speed slows down whenever the vehicle stops.



632615

For example, fast wiping speed will slow to normal wiping speed.

As soon as the vehicle moves off, wiping will return to the speed originally selected.

Any action on the stalk **1** overrides and cancels the automatic function.

Vehicle fitted with front windscreen wiper rain sensor

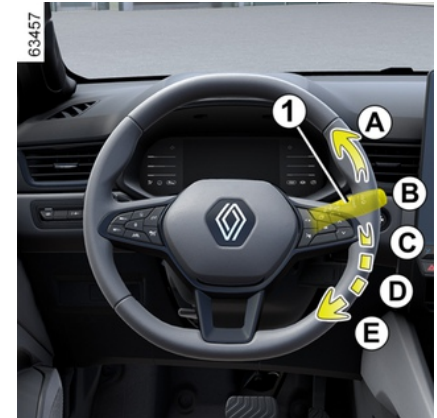

62615



The rain sensor is located on the windscreen, in front of the interior rear view mirror.

A. a single sweep of the wipers

A short push will trigger one sweep of the wipers.

B. stopping

C. automatic wiper function

When this position is selected, the system detects water on the windscreen and triggers the wipers at a suitable wiping speed.

It is possible to change the triggering threshold and the interval between sweeps by turning the ring **2**:

- **F**: minimum sensitivity;
- **G**: maximum sensitivity.

The higher the sensitivity, the quicker the wipers will react and the faster the wipe.

When activating automatic wiping or when increasing sensitivity, one sweep of the blades is performed.

Note:

- the rain sensor is only intended as a driving aid. In the event of reduced visibility, the driver should manually activate the wipers. In foggy weather or during snowfalls, wiping is not automatically triggered and remains under the driver's control;
- in the event of temperatures below zero, automatic wiping is not activated when the vehicle is started. It is automatically activated as soon as the vehicle exceeds a certain speed (approximately 5 mph (8 km/h));
- do not activate automatic wiping in dry weather;
- fully de-ice the windscreen before activating automatic wiping;
- when washing the vehicle under a roller type car wash, set the stalk **1** to position **B** to deactivate automatic wiping.

Operating faults

In the event of a malfunction of the automatic wiping, the wiper is set to intermittent wiping.

Call an approved dealer.

The rain sensor operation may be interrupted in the event of:

- damaged windscreen wipers: a film of water or traces left by a blade in the sensor's detection zone may increase the response time of the automatic wiper, or increase the wiping frequency;
- a windscreen with any chip or crack near the sensor, or a windscreen covered in dust, dirt, insects, ice, the use of washing wax and water-repellent chemicals. The windscreen wiper will be less sensitive or may even not react at all.

D. slow continuous wiping

E. fast continuous wiping

Special feature

When driving the vehicle, the wiping speed slows down whenever the vehicle stops.

For example, fast wiping speed will slow to normal wiping speed.

As soon as the vehicle moves off, wiping will return to the speed originally selected.

Any action on the stalk **1** overrides and cancels the automatic function.

Precautions

- In the event of ice, check whether the blades are stuck to the windscreen before operating the wiping mecha-

WIPER

nism. If you activate the wipers while the blades are stuck down with ice, you may risk damaging both the blade and the wiper motor.

- Do not activate the wipers on a dry screen. This will lead to premature wear or damage to the blades.

Specific front wiper position (service position)

This position enables the blades to be lifted to remove them from the windscreen.

It may be useful to:

- clean the blades;
- release the blades from the windscreen in winter;
- replace the blades → 342.

With the ignition on or engine started, lift the stalk **1** twice to position **A** (single sweep).

The blades stop slightly away from the bonnet.

To return the blades to the lowered position, with the ignition on, ensure that the wipers have folded down onto the windscreen, then move the stalk **1** to position **A** (single sweep).

Before switching on the ignition, place the wipers on the windscreen. Otherwise, there may be a risk of damage to the bonnet or the wipers when they are switched on.

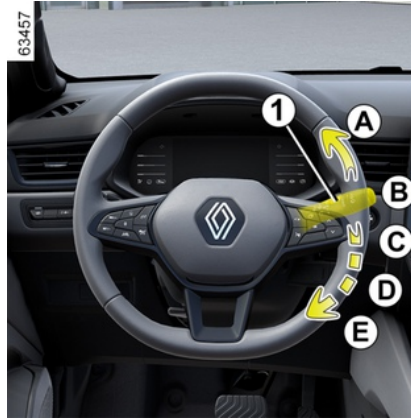

Before any action involving the windscreen (washing the vehicle, de-icing or cleaning the windscreen, etc.) return the stalk **1** to position **B** (park).

Risk of injury and/or damage.



In the event of obstacles on the windscreen (dirt, snow, ice etc.), clean the windscreen (including the central area located behind the interior rear view mirror) before starting the wipers (risk of motor overheating). If an object is preventing a blade from moving, it may stop functioning.

Remove the obstacle and reactivate the wiper using the wiper stalk.

Windscreen washer

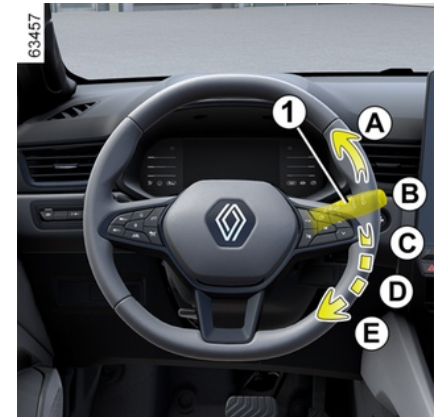

WIPER

With the ignition on, pull the stalk **1** then release.

A longer pull will trigger, in addition to the windscreen washer, two sweeps of the wipers followed, a few seconds later, by a third.

On vehicles fitted with a multimedia screen, you can choose to activate or deactivate the third sweep of the blades → **112**.

Note: in temperatures below zero, the washer liquid may freeze on the windscreen, reducing visibility. Heat the windscreen using the demister control before cleaning.



When working in the engine compartment, ensure that the windscreen wiper stalk is in position

B (stop).
Risk of injury.



Efficiency of a wiper blade

Check the condition of the wiper blades. How long they last depends on you:

- it must remain clean: clean the blade and the screen regularly with soapy water;
- do not use it when the screen is dry;
- free it from the screen when it has not been used for a long time.

In all cases, replace it as soon as it begins to lose efficiency: approximately once a year → **342**.

Precaution for using the wipers

- In freezing or snowy conditions, clear the screen before starting the wipers (risk of motor overheating);
- ensure that no objects are obstructing the travel of the blade.

Rear windscreen wash, wiper

Rear windscreen wiper



62615



With the ignition on, rotate the ring **3** on the stalk **1** until the symbol is aligned with the mark **2**:

- **off**;
- **intermittent wiping**.

The wipers will pause for several seconds between sweeps. The wiping frequency varies according to the vehicle speed;

- **slow continuous wiping**.

To stop the operation, rotate the ring **3** again.

Note:

WIPER

When washing using a roller type car wash, return the ring **3** on the stalk **1** to the stop position to deactivate automatic wiping.

Follow usage recommendations.



Do not use the wiper arm to open or close the tailgate.



Before taking any action involving the rear screen (washing the vehicle, de-icing, cleaning, etc.) return the stalk **1** to the off position.

Risk of injury and/or damage.



Efficiency of a wiper blade

Check the condition of the wiper blades. How long they last depends on you:

- it must remain clean: clean the blade and the screen regularly with soapy water;
- do not use it when the screen is dry;
- free it from the screen when it has not been used for a long time.

In all cases, replace it as soon as it begins to lose efficiency: approximately once a year → **342**.

Precaution for using the wipers

- In freezing or snowy conditions, clear the screen before starting the wipers (risk of motor overheating);
- ensure that no objects are obstructing the travel of the blade.

Activation/deactivation of the rear screen wiper

Engaging reverse gear triggers intermittent wiping (if the front wipers are in operation). If your vehicle is equipped with a vehicle settings customisation

menu, you can opt to activate or deactivate this function → **112**.

For vehicles not fitted with a settings customisation menu, you can have this function deactivated by an authorised dealer.

In the event of obstacles present on the rear window (dirt, snow, etc.), the wiper will try to sweep away all the obstacles. If an obstacle prevents the blade from moving, it can be stopped. Remove the obstacle, wait for around 30 seconds and reactivate the wiper using the wiper stalk.

Precautions

- In the event of ice, check that the blades are not stuck to the windscreen before operating the wipers. If you activate the wiper while the blade is blocked by ice, you risk damaging both the blade and the wiping motor.
- Do not operate the wipers on a dry screen. This will lead to the premature wear or damage to the blades.

Rear screen wash/wipe



With the ignition on, push and hold the stalk **1** then release it.

Holding the stalk for longer will trigger (in addition to the windscreen washer) two sweeps of the wipers followed, a

WIPER

few seconds later, by a third (drip wiping function).

When the stalk is released, it returns to the rear wipe position.

2

FUEL TANK

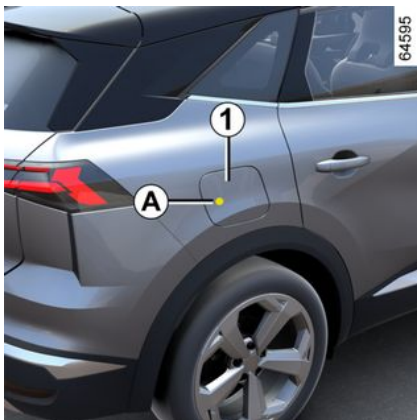

Useful capacity of fuel tank: approximately 10.5 gal (48 litres).

With the vehicle unlocked, to open the flap **1**, press zone **A**, then release. The flap **1** opens slightly.

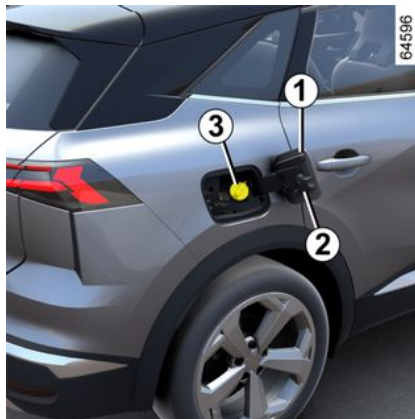

Use the cap holder **2** on the flap **1** during filling to hold the cap **3** in place. For details on filling the tank, refer to the information on "Filling with fuel". To close it, press on the fuel filler flap by hand, as far as it will go.



Fuel filler cap: this is a specific type.

If you have to replace it, make sure it is identical to the original cap. Contact an approved Dealer.

Never place the cap near a source of heat or flame.

Do not wash the filler area with a high pressure washer.

Fuel grade

Use a high-grade fuel that complies with the legislation in force in each country and that complies with the specifications given on the label on the flap **1** → **357**.



Fuel types that conform to European standards with which the engines of vehicles sold in Europe are compatible: refer to the table → **357**.

It is **essential** to use unleaded petrol. The octane rating (RON) must comply with the information shown on the label on the fuel filler flap **1** → **357**.

FUEL TANK



After filling, check that the cap and cover are closed.

Filling with fuel

With the ignition off, insert the nozzle and insert it **fully** before turning it on to fill the fuel tank (risk of splashing).

Keep the nozzle in this position throughout the entire filling operation.

When the pump cuts out automatically at the end of the filling procedure, a maximum of two further filling attempts may be made, as there must be sufficient space in the fuel tank to allow for expansion.

Make sure that no water enters the fuel tank during filling.

After filling, refit the cap **3** and close the flap **1** to prevent any water or foreign bodies from entering the system.

Always make sure that the cap **3**, the flap **1** and its perimeter remain clean and free of dust, mud, dirt, etc.

Special case

When the vehicle has been stopped for around three months, **you must add fuel to prevent damage to the fuel pump.**

To do this, with the ignition off, fill up with fuel or top up with at least approximately 2.20 gallons (**10 litres**) then start the engine to operate the pump and renew the fuel in the circuit.

If it is not possible to add at least 1.10 gallons (5 litres) of fuel due to the fuel level in the tank, drive the vehicle until the tank has capacity.

Using leaded petrol will damage the antipollution system and may lead to a loss of warranty.

To ensure that the fuel tank is not filled with leaded petrol, the fuel tank filler neck contains a restrictor fitted with a foolproof system which **only allows the nozzle for unleaded petrol to be used** (at the pump).



No modifications whatsoever are permitted on any part of the fuel supply system (electronic units, wiring, fuel circuit, injectors, protective covers, etc.) as this may be dangerous (unless undertaken by qualified Network personnel).



Persistent smell of fuel

If you notice a persistent fuel odour you should:

- stop the vehicle when traffic conditions allow it and switch off the ignition;
- switch on the hazard warning lights and ask your passengers to leave the vehicle and stay clear of the traffic;
- contact an authorised dealer.

RUNNING IN

For the first **620 miles** (1,000 km) do not exceed 80 mph (130 km/h) in the highest gear, or 3,000 to 3,500 rpm.

You can only expect top performance from your vehicle after approximately **1,860 miles (3,000 km)**.

Note: for a new vehicle in the running-in phase: the coolant level may be higher than the "MAXI" mark on the tank, then drop to between the "MINI" and "MAXI" marks. This does not present a risk.

Service intervals: refer to your vehicle's maintenance document.

STARTING, STOPPING THE ENGINE

Ignition-starter switch on a vehicle with card



64561



62618

The card must be in the detection zone **1**.

To start:

– in P position, press the brake pedal and button **2**.

The READY message appears on the instrument panel, accompanied by a beep.

The message disappears when the vehicle speed is above approximately 3 mph (5 km/h).

Release the brake pedal once the engine has started;

Special features

– If one of the conditions required for starting is not met, the "Press brake + START" or "Press clutch + START" or

"Set gearbox to P" message appears on the instrument panel;
– in some cases it is necessary to move the steering wheel while pressing the start button **2** to help unlock the steering column – in this case the Turn steering wheel + START" message will inform you.



Driver's responsibility when parking or stopping the vehicle

Never leave an animal, child or adult who is not self-sufficient alone in your vehicle, even for a short time.

They may pose a risk to themselves or to others by starting the engine, activating equipment such as the electric windows or locking the doors.

Also, in hot and/or sunny weather, please remember that the temperature inside the passenger compartment increases very quickly.

RISK OF DEATH OR SERIOUS INJURY.

STARTING, STOPPING THE ENGINE



Never switch off the ignition before the vehicle has come to a complete stop. Once the engine has stopped, the brake servo, power-assisted steering etc., and the passive safety devices such as the airbags and pretensioners will no longer operate.



Do not park the vehicle or run the engine in locations where combustible substances or materials such as grass or leaves can come into contact with the hot exhaust system.

"Hands-free" starting with the luggage compartment open

In this case, the card should not be located in the luggage compartment, to prevent the risk of loss.

Accessories function

(switching on the ignition)

Once you have gained access to your vehicle, you may use some of its functions (radio, navigation, wipers, etc.).

To use the other functions, with the card in the passenger compartment, press the button **2** without pressing the pedals.

Operating faults

In certain cases, the hands-free card may not work:

- when the card battery is flat, etc.;
- the card is near to appliances operating on the same frequency (monitor, mobile phone, video game device, etc.);
- the vehicle is located in a high electromagnetic radiation zone.

The "Place card in zone + START" message appears on the instrument panel.



Press the brake pedal, then place the card **4** (button side) on the placement

STARTING, STOPPING THE ENGINE

area **3**. Press the button **2** to start the vehicle. The message goes out.

Conditions for stopping the engine



The vehicle must be stationary, with the lever in **P** position.

The READY message is displayed on the instrument panel.

With the card in the vehicle, press the button **2**: the engine is switched off. The steering column is locked when a door is opened or the vehicle is locked. The READY message disappears from the instrument panel.

If the card is no longer in the passenger compartment or the card's battery is flat, when the vehicle is stationary

and you attempt to switch of the engine, the "Card missing press and hold START" message appears on the instrument panel: press and hold the button **2** for more than three seconds.

If the card is no longer in the passenger compartment, make sure you can retrieve it before pressing and holding the button. Without the card, you will not be able to restart the vehicle.

With the engine switched off, any accessories being used (radio, etc.) will continue to function for approximately 10 minutes.

When the driver's door is opened, the accessories stop working.

With the vehicle stationary and in electric operating mode, the "ENGINE ON SWITCH OFF IGNITION" message appears on the instrument panel accompanied by a beep if:

- the driver's seatbelt is not fastened;
- the bonnet is open;
- the driver's door is open.



When you leave your vehicle, especially if you have your card with you, check that the engine is completely switched off.



Driver's responsibility when parking or stopping the vehicle

Never leave an animal, child or adult who is not self-sufficient alone in your vehicle, even for a short time.

They may pose a risk to themselves or to others by starting the engine, activating equipment such as the electric windows or locking the doors.

Also, in hot and/or sunny weather, please remember that the temperature inside the passenger compartment increases very quickly.

RISK OF DEATH OR SERIOUS INJURY.

GEAR CONTROL

Automatic gearbox, electronic lever

Electronic selector lever



1 electronic selector lever

R reverse

N neutral

D automatic mode

B forward gear with increased regenerative braking

P park, button **2**

3 Accessible gear grid

On the instrument panel, the following symbols inform you:

48457

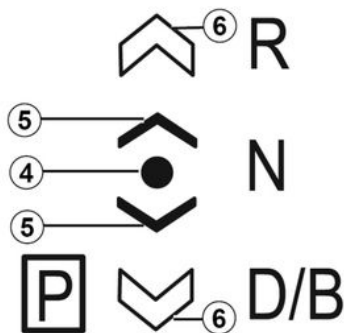

4 : position of the engaged gear;

5 : position accessible from the current position by moving the selector lever **1** one notch forwards or backwards;

6 : position accessible from the current position by moving the selector lever **1** two notches forwards or backwards.

Symbols **5** or **6** are displayed to indicate the gears that can be selected. If these symbols are absent this indicates that the gears cannot be selected from the current position.



The triangle **7** is displayed when manual mode is activated.



Check that the P indicator light on the instrument panel and the indicator light built into the button **2** are displayed before leaving the vehicle.

Risk of loss of immobilisation of the vehicle

GEAR CONTROL

One-touch selector



Move the selector lever **1** one or two notches forwards or backwards to engage the desired position (**R**, **N**, **D** or **B**), depending on the vehicle, then release the lever and it will return to its stable position.

The selected position is displayed on the instrument panel along with the indicator light **4** in front of the position. If certain conditions prevent shifting from one position to another, the requested position flashes on the instrument panel.

To engage position P



With the vehicle at a standstill and the engine or the ignition on, press the button **2** to engage the position **P**. The warning light on button **2** lights up or orange once the park position **P** on the gearbox is engaged.

To disengage position P

With the vehicle stationary and the engine on, press the brake pedal and, move the **1** selector lever forwards or backwards according to the position desired. The **2** button warning light switches off.

If the brake pedal is not fully depressed, the message "Press brake"

and the warning light  are displayed on the instrument panel.

Note:

- if the driver opens their door to leave the vehicle and **P** position has not been engaged, a beep sounds and the "P not engaged" message is displayed on the instrument panel;
- the warning light  appears each time the brake pedal must be pressed to change the automatic gearbox lever position.

To engage neutral

With the vehicle stopped and the engine on, to select **N** position, move the **1** selector lever one notch forwards or backwards according to the gear engaged.

Driving in automatic mode

With the vehicle stationary and the engine on, move the selector lever **1** two notches backwards to engage position **D**.

If one of the conditions is not applied, **D** flashes for around 5 seconds and the message "Apply brake" is displayed on the instrument panel for approximately 15 seconds.

GEAR CONTROL

In the majority of driving conditions, you will no longer have to use your gear lever: the gears change "automatically", at the right time, to a suitable engine speed because the automated system takes the vehicle's load, road profile and the selected driving style into account.

Note: with the engine running and the vehicle travelling at between 0 and 5 mph (0 and 8 km/h), in position **N** or **R**, it is necessary to depress the brake pedal to engage position **D**. This is useful during parking manoeuvres requiring a number of alternate forward and reverse movements.

Economical driving

When driving, always leave the lever in position **D**, keeping the accelerator pedal lightly depressed to ensure automatic gear changes at a lower engine speed.

Accelerating and overtaking

Depress the accelerator pedal briskly and fully (so that it goes beyond the kickdown point).

It is also possible to shift down at any time for overtaking purposes, by pressing the left-hand paddle.

Driving in mode **B**

This mode enables driving with greater regenerative engine braking. When re-

leasing the accelerator pedal, the vehicle uses regenerative braking to slow down.

Thus the electric motor generates a higher electrical current which enables the traction battery to be recharged.

In **B** mode, the regenerative braking will be reduced if the accumulator is cold or completely charged.



The engine brake should under no circumstances be used as a substitute for the brake pedal.

To select reverse gear

With the vehicle stationary and the engine on, move the selector lever **1** two notches forwards to engage position **R**.

If the brake pedal is not depressed, a beep will sound, the display of position **R** flashes for around 5 seconds in the grid shown on the instrument panel, and a message "Press brake" is displayed for around 15 seconds.

Note: with the engine running and the vehicle moving at between approximately 0 and 5 mph (8 km/h) position **N**, or **D**, you need not press the brake pedal in order to engage **R**. This is

useful during parking manoeuvres requiring a number of alternate forward and reverse movements.

Gear change paddles **8** and **9**



Depending on the vehicle, paddles **8** and **9** can be used to change gear when the lever is in **D** position.

8: change to a lower gear.

9: change to a higher gear.

The **P**, **N** and **R** positions cannot be accessed using paddles.

Driving in manual mode

When driving in **D** position you can switch to manual driving mode by selecting paddles **8** and **9** on the steer-

GEAR CONTROL

ing wheel. Depending on the vehicle, two manual driving modes are available:

– the **"temporary" manual mode** can be used to force gear shifting by briefly pressing one of the two paddles. Driving mode **D** and the engaged gear appear on the instrument panel. The letter **D** and the lower arrow appear brighter on the indicator light **3**.

Note: the gearbox adjusts itself to automatic mode **D** if the gear engaged is no longer optimal to vehicle performance or if no action has been taken on a paddle for a certain amount of time.

– **permanent manual mode is activated** by pressing and holding either of the paddles. The driving mode **M** and the engaged gear will appear on the display **10** on the instrument panel. All of the letters and the lower arrow appear as backlighting on the indicator light **3**.





Note: depending on the vehicle, the return to automatic mode is carried out by pressing and holding the right-hand paddle or by moving the one-touch lever **1** one or two notches backwards.

In all situations:

- to shift down through the gears, press the left-hand paddle;
- to move up through the gears, press the right-hand paddle.

Note: depending on the display, the +

and - or  and  indicator lights will suggest shifting up or down a gear.

Special cases

In certain driving conditions (resulting in, for example, engine protection, operation of the Electronic Stability Control programme: ESC, etc.) "the automated system" may change the gear automatically.

Likewise, to prevent incorrect manoeuvres, a gear change may be refused by the automatic system: in this case the gear display flashes for a few seconds as a warning.

Special circumstances

- **If the road type or weather conditions** (steep uphill slopes, sudden downhill slopes, deep snow, sand or mud) make it difficult to stay in automatic mode, depending on the vehicle, it is advisable to switch to manual mode using the paddles. This will prevent the "automatic gearbox" from changing gears repeatedly when driving uphill, and permit engine braking on long descents.
- **In cold weather**, wait a few seconds before disengaging **P** or **N** position and then engage the lever in **D** or **R** position to prevent the engine stalling.

GEAR CONTROL

Parking the vehicle

On vehicles equipped with lever **1**, position **P** is automatically engaged as well as the electronic parking brake (on vehicles equipped) when:

- the engine is stopped;
- the driver's seatbelt is unfastened and the vehicle is stopped;
- the driver's door is opened and the vehicle is stopped.

P is displayed on the instrument panel and the **P** button warning light is on.

As position **P** is **automatically engaged** when the engine is stopped, it is sometimes necessary to place the vehicle in position **N** for some car washes, for example:

- with the engine on, press the **P** button, move the selector lever **1** one notch forwards or backwards then stop the engine;
- with the engine off and the ignition on, move the selector lever **1** a notch forwards or backwards then switch-off the engine.

The next time the engine is restarted, position **P** is engaged automatically according to the cases described earlier.



The **P** position must only be engaged when the vehicle is stationary.



When facing uphill, to remain stopped, do not keep your foot on the accelerator.

Risk of overheating the automatic gearbox.



For safety reasons, do not switch off the ignition before the vehicle has come to a complete standstill.

Maintenance period

Refer to the maintenance document for your vehicle or consult an Approved Dealer to check whether the automatic gearbox requires scheduled maintenance.

If it does not need to be serviced, there is no need to top up the oil.

Operating faults

– **when driving**, if the "Check gearbox" message appears on the instrument panel this indicates a fault.

Contact an approved dealer as soon as possible;

– **when driving**, if the message "Gearbox overheating" appears on the instrument panel, stop as soon as possible to let the gearbox cool down and wait for the message to disappear;

– **breakdown recovery of a vehicle with an automatic gearbox** → 332.

In the event of engine failure or an electrical fault (battery fault) affecting operation of the automatic gearbox, ensure that the vehicle is properly immobilised.



An impact to the underside of the vehicle while manoeuvring (e.g. striking a post, raised kerb or other street furniture) may result in damage to the vehicle (e.g. deformation of an axle).

To avoid any risk of accident, have your vehicle checked by an approved dealer.

SPECIAL FEATURES OF PETROL VERSIONS

The following operating conditions:

- driving for long periods when the low fuel level warning light is lit;
- using leaded petrol;
- using lubricant or fuel additives which are not approved.

Or operating faults such as:

- a faulty ignition system, running out of fuel or disconnected spark plugs resulting in the engine misfiring or jerkiness while driving;
- loss of power;

as they may cause the catalytic converter to overheat and thus reduce its efficiency, **or damage it irreparably and cause heat damage to the vehicle.**

If you notice any of the above operating faults, have the necessary repairs carried out as soon as possible by an approved dealer.

These faults may be avoided by regularly taking your vehicle to an approved Dealer at the intervals specified in the maintenance document.

Starting problems

To avoid damaging the catalytic converter or the starter, and to prevent premature wearing of the battery, **do not keep trying to start the engine (using the start button, or by push-**

ing or towing the vehicle) without having identified and corrected the starting fault.

If the fault cannot be identified, do not keep trying to start the engine, but contact an approved Dealer.



Do not park the vehicle or run the engine in locations where combustible substances or materials such as grass or leaves can come into contact with the hot exhaust system.

Particle filter

The particle filter is used in the treatment of exhaust gases from petrol engines.

Depending on the vehicle, the warning light  displayed on the instrument panel indicates that the filter is becoming clogged and requires cleaning. To

clean it, when the  warning light appears, and as traffic conditions and speed limits allow, drive at between about 31 mph (50 km/h) and 68 mph (110 km/h) until the light goes out.

After between approximately 5 and 20 minutes, the warning light should go out.

Note: the warning light may go out after 20 minutes if the driving conditions required to clean the filter are not fully met.

If the vehicle is stopped before the warning light disappears you will have to restart the process from the beginning.

If the filter becomes excessively saturated, the  warning light and,

depending on the vehicle, the  warning light will appear on the instrument panel, accompanied by the message "Check ignition". In this case, please consult an Authorised Dealer.

If the  warning light and, de-

pending on the vehicle, the  warning light appears, accompanied by the message "Risk of engine failure", stop the vehicle, switch off the engine and contact an Approved Dealer.

SPECIAL FEATURES OF PETROL VERSIONS



For your own safety, the **STOP** warning light requires you to stop immediately, as soon as traffic conditions allow. Switch off the engine and do not restart it. Call an approved dealer.

PARKING BRAKE

Electronic parking brake

Assisted operation

Applying the electronic parking brake



With the vehicle stationary, the electronic parking brake can be used to immobilise the vehicle:

– by pressing the engine start/stop button 1;

or

– when the driver's seat belt is unfastened;

or

– when the driver's door is opened;

or

– when you set gear lever 2 to P position.



The electronic parking brake can be used to immobilise the vehicle. Before leaving the vehicle, check that the electronic parking brake is fully applied.

Warning light 3 on switch 4 and

warning light  on the instrument panel illuminate to show that the parking brake is applied but switch off when the doors are locked. Depending on the vehicle, a sticker is located on the upper section of the windscreen to remind you of this.

In all other instances, e.g. **if the engine stalls**, the electronic parking brake is not applied automatically. Manual mode must be used. For certain country-specific model versions, the assisted brake application function is not activated. See the information on "Manual operation".

To confirm that the electronic parking brake is applied, the message "Parking

brake on" and warning light  on the instrument panel and warning light 3 on switch 4 light up.

PARKING BRAKE

After the engine is switched off, the indicator light **3** goes out a few minutes after the electronic parking brake has

been applied and the  warning light goes out when the vehicle is locked.

Note: in some situations (electronic parking brake failure, manual release of the parking brake, etc.), a beep sounds and the "Apply parking brake" message appears on the instrument panel to indicate that the electronic parking brake has been released:

- with the engine on: when the driver's door is opened;
- with the engine off (e.g. when the engine stalls): when a front door is opened.

In this case, pull and release the switch **4** to apply the electronic parking brake.

Assisted release of the parking brake

The brake will be released as soon as the vehicle starts and accelerates.

Manual operation

You can apply the electronic parking brake manually.

Manually applying the electronic parking brake

Pull the switch **4**. Warning light **3** and warning light  on the instrument panel light up.

Manually releasing the electronic parking brake



Press the switch **1** without pressing the pedals to switch the ignition on. Press the brake pedal then press switch **4**: indicator light **3** on the

switch and indicator light  displayed on the instrument panel go out.



The electronic parking brake can be used to immobilise the vehicle. Before leaving the vehicle, check that the electronic parking brake is fully applied.

Warning light **3** on switch **4** and

warning light  on the instrument panel illuminate to show that the parking brake is applied but switch off when the doors are locked.

Depending on the vehicle, a sticker is located on the upper section of the windscreen to remind you of this.

Brief stop

To apply the electronic parking brake manually (when stopping at a red light, stopping when the engine is running, etc.): pull and release the switch **4**. The brake is released as soon as the vehicle is started up again.

Special cases

To park on a slope or while towing a trailer, for example, pull switch **4** for a

PARKING BRAKE

few seconds to enable maximum braking.

To park, with the electronic parking brake released (if there is a risk of freezing, for example):

- engage any gear or the P position: the drive wheels will be mechanically locked by the driveshaft;
- stop the engine by pressing the engine Start/Stop button **1**;
- unfasten the driver's seat belt;
- open the driver's door;
- manually release the electronic parking brake (please see the paragraph on "Manually releasing the electronic parking brake");
- depending on the vehicle, the electronic parking brake is applied automatically. You will have to release it manually.

Versions with an automatic gearbox

For safety reasons, automatic release is deactivated when the driver's door is open or not shut properly and the engine is running (in order to prevent the vehicle from moving without the driver). The "Release parking brake manually" message appears on the instrument panel when the driver presses the accelerator pedal.



Never leave your vehicle without re-engaging **P** position and switching off the engine. This is

because when the vehicle is stationary with the engine running and a gear engaged, the vehicle may begin to move if you accelerate.

There is a risk of accidents.



If no lights or sounds are apparent, this indicates a fault in the instrument panel. This indicates that it is essential to stop immediately (as soon as traffic conditions allow). Ensure that the vehicle is correctly immobilised and contact an approved Dealer.

Operating faults

– If there is a fault, the  warning light on the instrument panel lights up accompanied by the "Check parking brake" message and, in some cas-

es, the  warning light.

Contact your approved Dealer straight away.

– If there is an electronic parking

brake fault, warning light  lights up accompanied by the "Parking brake fault" message, a beep and in

certain cases the warning light .

This indicates that it is essential to stop immediately (as soon as traffic conditions allow).



If the "DANGER electrical fault" or "Check battery" or "Braking system fault" message appears, you must immobilise the vehicle by engaging first gear (manual gearbox), **P** position (automatic gearbox) or by pulling the switch **4** for approximately 10 seconds. If the conditions and the slope require it, chock the wheels of the vehicle.

Risk of loss of immobilisation of the vehicle.

Call an approved dealer.

PARKING BRAKE

"Autohold" function

Vehicle stopped (e.g. at a red light, an intersection, a traffic jam, etc.), the function ensures braking force even when the driver releases the brake pedal.

The braking force is released as soon as the driver accelerates sufficiently with a gear engaged.

Activation



Press the switch **2**.

The indicator light **1** on the switch **2** lights up to confirm that the function is activated.

Deactivation



Press the brake pedal and switch **2** simultaneously.

The indicator light **1** on switch **2** disappears to confirm that the function is deactivated.

If the braking force is maintained, the parking brake is applied automatically when:

- the driver exits the vehicle;
- or
- the vehicle is immobilised for more than approximately three minutes.

Conditions for maintaining the braking force

The following conditions must be met:

- the driver's seat belt is fastened; and
- the electronic parking brake is released;
- and
- the vehicle is not stationary on a very steep slope.

The maintained braking force is confirmed by the  warning light on the instrument panel.

Conditions for interrupting the braking force

The following conditions must be met:

- the driver accelerates sufficiently with a gear engaged;
- or
- the driver disables the function.

Warning light  goes out on the instrument panel.

 Upon each start-up, the function continues the mode set at the time the engine was last switched off.

ENVIRONMENT

Your vehicle has been designed with respect for the **environment** in mind for its entire service life: during its production, usage and at the end of its service life.

3

Manufacture

Your vehicle has been manufactured at a factory which complies with a policy to reduce the environmental impact on the surrounding areas (reduction of water and energy consumption, visual and noise pollution, atmospheric emissions and waste water; sorting and reusing waste).

Emissions

Your vehicle has been designed to emit fewer greenhouse gases (CO₂) while in use, and therefore to consume less fuel (e.g. 225 g/mile (140 g/km), equivalent to 1.10 gal/62 miles (4.2 l/100 km) for a petrol vehicle).

Our vehicles are also equipped with an emission control system including a catalytic converter, an oxygen sensor and a petrol vapour filter (the latter prevents vapour from the fuel tank being released into the open air), etc.

Please make your own contribution towards protecting the environment too.

- Parts and vehicles at the end of their life must not be thrown away. They must be handed to a legal entity that complies with environmental standards.
- Worn parts and components that are replaced during routine vehicle maintenance, such as tyres or oil (tanks emptied or filled) must be disposed of at dedicated collection points.
- Worn **electrical** and **electronic** components that are replaced (such as batteries) must not be thrown away as rubbish. Take them to an approved dealer or consult your local authority for information on appropriate recycling facilities.



- To optimise the recycling of your vehicle at the end of its life, you can contact an approved dealer or visit the manufacturer's website to be directed to collection points that guarantee respect for the environment according to local laws.

Recycling

Your vehicle is at least 85% recyclable and at least 95% recoverable.

To achieve these objectives, many of the vehicle components have been designed to enable them to be recycled.

The materials and structures have been carefully designed to:

ENVIRONMENT

- allow these components to be easily removed and reprocessed by specialist companies;
- promote a circular economy (re-use, recycling, recovery, etc.)

This is particularly true for electrified vehicle batteries.

In order to preserve raw material resources, your vehicle also includes many parts made from recycled plastics or renewable materials.

MAINTENANCE AND ANTIPOLLUTION ADVICE

Your vehicle complies with criteria for recycling and recovering vehicles at the end of their service life, which entered into force in 2015.

Some of the parts on your vehicle have been designed to be recycled later.

These parts are easily removable in order to be collected and reprocessed in recycling networks.

Furthermore, by virtue of its design, moderate fuel consumption and initial settings, your vehicle also conforms to current anti-pollution regulations. The manufacturer is actively striving to reduce pollutant exhaust gas emissions and to save energy. But the fuel consumption of your vehicle and the level of pollutant exhaust gas emissions are also your responsibility. Ensure that it is maintained and used correctly.

Maintenance

It is important to remember that failure to respect antipollution regulations could lead to legal action being taken against the vehicle owner.

In addition, replacing engine, fuel supply system and exhaust components with parts other than those originally recommended by the manufacturer may alter your vehicle so that it no

longer complies with antipollution regulations.

Have your vehicle adjusted and checked by an approved dealer, in accordance with the instructions given in your maintenance schedule: they will have all the equipment necessary for ensuring that your vehicle is maintained to its original standard.

Engine adjustments

- **Spark plugs:** for optimum fuel economy, efficiency and performance, the specifications which have been laid down by our Design Department must be strictly applied.

If the spark plugs have to be changed, use the make, type and gap specified for your vehicle's engine. Contact an authorised dealer for this.

- **Ignition and idle speed:** no adjustment is needed.
- **Air filter, fuel filter:** a choked element hinders performance. It must be replaced.

Exhaust gas monitoring system

The exhaust gas monitoring system will detect any operating faults in the vehicle's exhaust gas antipollution system.

If this system malfunctions, toxic substances may be released into the at-

mosphere or mechanical damage may occur.



This indicator light on the instrument panel indicates possible faults in the system:

This lights up when the ignition is switched on and goes out when the engine is started.

- If it lights up continuously, contact an approved dealer as soon as possible;
- If it flashes, reduce the engine speed until the light stops flashing. Contact your approved Dealer as soon as possible;

DRIVING ADVICE, ECO-DRIVING

Eco-driving

Fuel consumption, and energy consumption on E-Tech Full Hybrid versions, is approved according to a standard and regulatory procedure.

Identical for all manufacturers, this enables vehicles to be compared with one another.

Consumption in real time depends on vehicle usage conditions, the equipment fitted and the user's driving style.

To optimise fuel consumption, please refer to the following advice.

Depending on the vehicle, there may be different functions available to help you reduce your fuel consumption:

- the rev counter;
- the driving style indicator;
- the journey record and eco-driving advice via the multimedia screen;
- acceleration indicator Eco;
- ECO mode;
- the charge meter on E-Tech Full Hybrid versions.

If fitted on the vehicle, the navigation system provides additional information.

On the instrument panel A or B

Depending on the vehicle, the information display can be organised and customised based on the instrument panel

customisation style selected from the multimedia screen.

Driving style indicator 1

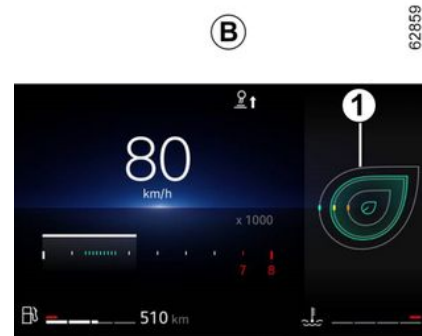

1 Informs you about the driving style adopted in real time. You will be notified by indicator 1.

The more petals displayed on the indicator 1, the more your driving is flexible and economical.

If you regularly monitor this indicator, you will reduce your vehicle's fuel consumption.

Please refer to the multimedia instructions for further information.

DRIVING ADVICE, ECO-DRIVING

Acceleration indicator Eco 2

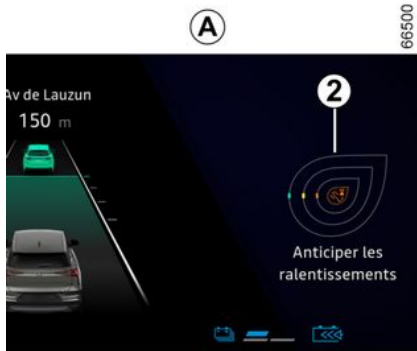

This informs you in real time whether you are accelerating moderately or strongly.

You will be notified by indicator **2**:

- green: acceleration is moderate and correct;
- white: acceleration is too high;
- grey: acceleration is high.

Note: it is not possible to simultaneously display the driving style indicator **1** and the Eco acceleration indicator **2**.

On the multimedia screen

Journey record



the multimedia screen **3**, enabling you to view information on your last journey.

This indicates:

- general score;
- score evolution;
- distance without fuel consumption.

An overall rating from 0 to 100 is displayed to let you assess your eco driving performance.

The higher the rating, the lower the fuel consumption.

Eco advice is given to help improve your performance.

With your favourite journeys saved, you can compare your performance between trips and the performance of other vehicle users.

Please refer to the multimedia instructions for further information.

ECO mode

ECO mode is a function which optimises fuel consumption.

It affects certain driving operations (acceleration, shifting gears, cruise control, deceleration etc.).

Limiting acceleration enables low fuel consumption in urban and surrounding areas.

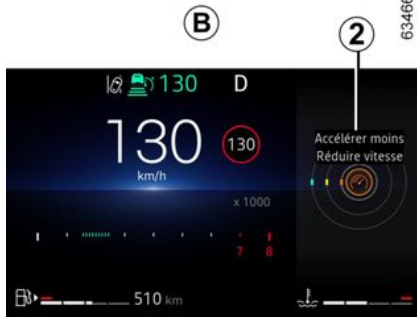

Once the engine is switched off, you will see "Journey record" displayed on

DRIVING ADVICE, ECO-DRIVING

Activating the function



- by pressing switch **4**;
- by pressing the switch **5** → 283;
- from the multimedia screen (refer to the multimedia instructions).

The warning light **Eco** comes on on the instrument panel to confirm activation.

While driving, it is possible to leave the ECO mode temporarily in order to improve engine performance.

To do this, press the accelerator pedal firmly and fully.

ECO mode is reactivated when you take pressure off the accelerator pedal.

Deactivating the function

Depending on the vehicle, the function can be deactivated either:

- by pressing switch **4**;
- by pressing the switch **5** → 283.

The warning light **Eco** goes out on the instrument panel to confirm deactivation.



Depending on the vehicle, the function can be activated either:

Charge meter



(on the instrument panel)

The charge meter gives the driver a real-time view of the vehicle's energy consumption.

Blue "Energy recovery" C usage zone

During driving, if you lift your foot off the accelerator pedal or press the brake pedal, the electric motor generates electrical current during deceleration and this energy is used to slow down the vehicle and recharge the traction battery.

"Energy consumption" D usage area

The colour of the charge meter varies:

DRIVING ADVICE, ECO-DRIVING

- **in green:** all-electric mode, the traction battery provides the energy required for the electric motor to power movement of the vehicle;
- **in white:** hybrid traction mode, the traction battery and/or the combustion engine provide the energy required to power movement of the vehicle.



The presence and display of this information depends on the type of ambient setting selected.

Driving advice, Eco-driving

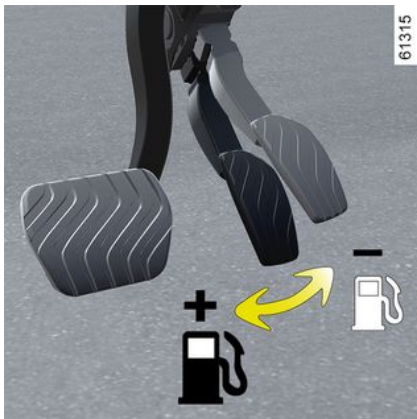

Heating levels

It is normal to notice an increase in the vehicle's fuel consumption when using the heating (particularly when the outside temperature drops below zero) or air conditioning.

Behaviour

- Drive carefully until the engine reaches its normal operating temperature, rather than let it warm up while the vehicle is stationary.
- Driving at high speed has a strong impact on the vehicle's fuel consumption or, in the case of E-Tech Full Hybrid vehicles, reduces the vehicle's range.
- "Sporty" driving reduces the range of an E-Tech Full Hybrid vehicle: opt for a "smoother" driving style.

Examples (at a steady speed):

- reducing the speed from approximately 80 mph (130 km/h) to 68 mph (110 km/h) saves up to around 20% of fuel;
- reducing the speed from approximately 56 mph (90 km/h) to 50 mph (80 km/h) saves up to around 10% of fuel.
- Dynamic driving involving heavy and frequent acceleration and braking is expensive on fuel in comparison to the time saved.

- Do not over rev the engine in the intermediate gears. You should always use the highest gear possible.
- Avoid sudden acceleration.
- Brake as little as possible. If you anticipate an obstacle or bend in advance, you may then simply release the accelerator pedal.
- Do not try to maintain the same speed up a hill, accelerate no more than you would on level ground. Keep your foot in the same position on the accelerator pedal.
- Double declutching and accelerating before switching off the engine are unnecessary in modern vehicles.
- Bad weather, flooded roads:



Do not drive through water if it is higher than the lower edge of the wheel rim.



Driver obstruction

On the driver's side, only use mats suitable for the vehicle, attached with the pre-fitted components, and check the fitting regularly. Do not lay one mat on top of another.
There is a risk of wedging the pedals.

DRIVING ADVICE, ECO-DRIVING

Tyres

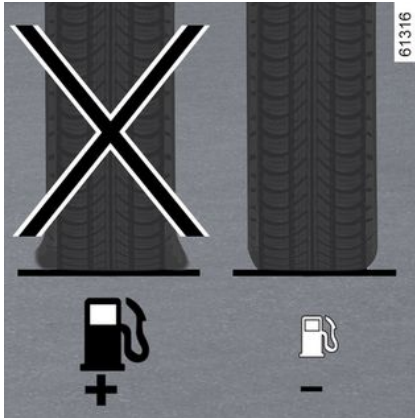

- An underinflated tyre increases fuel consumption.
- To optimise fuel consumption, set the highest speed tyre pressure or the recommended pressure indicated on the edge of the driver's door → **323**.
- The use of non-recommended tyres can increase fuel consumption.

Advice on use



- Favour ECO Mode.
- Electricity is fuel – switch off all the electrical components when they are not genuinely needed. **However** (safety first), keep your lights on when the visibility is bad ("see and be seen").
- Use the air vents. Driving with the windows open at 62 mph (100 km/h) will increase fuel consumption by 4%.
- Never fill the fuel tank right to the brim to avoid overflow.
- **On vehicles equipped with non-automatic air conditioning**, switch off the air conditioning when it is not required.

Advice for reducing consumption and helping to preserve the environment:

If the vehicle has been parked in the sun, open the doors for a few moments to let the hot air escape before starting the engine.

- Do not leave an empty roof rack fitted to the vehicle.
- It is better to fit a trailer for bulky objects.
- When towing a caravan, fit a wind deflector and adjust it carefully.
- Avoid using the vehicle for "door-to-door" calls (short journeys with long waits in between) because in such conditions the engine never reaches its optimal operating temperature.

ECO predictive driving assistant

Depending on the vehicle, using subscription-based maps this function allows you to adopt a more economical driving style.

When approaching a driving situation (roundabout, speed limit, etc.) the function informs the driver, via an indicator displayed on the instrument panel, at which moment to release the accelerator pedal.

If the driver takes this action it enables the vehicle to stop accelerating and to limit the use of the brakes.

DRIVING ADVICE, ECO-DRIVING

This enables a reduction in fuel consumption and wear of the brake pads and tyres.

Activation/deactivation

From the "Vehicle" world, select the "Driving aids" menu, then "ECO predictive driving assistant".



The ECO predictive driving assistant is subscription-based.

To manage the subscription, please refer to the multimedia instructions.

Operating principle



When a driving situation is about to occur, the warning lights **1** are **2** displayed on the instrument panel.

The warning light **2** prompts the driver to release the accelerator pedal.

The warning light **1** shows the imminent driving situation.

When the driver releases the accelerator pedal, the warning light **2** disappears from the instrument panel. The warning light **1** remains displayed on the instrument panel until the situation occurs.

If the driver does not adjust their speed, the warning lights **1** and **2** re-

main displayed on the instrument panel until the situation occurs.

Driving situations

The following driving situations are detected:



road bend;



speed limit;



roundabout;



toll;



intersection with a "Stop" or "Give way" road sign.

The function is not able to detect the following:

- slopes (uphill or downhill);
- intersections without a "Stop" or "Give way" road sign;
- traffic jams.

TYRE PRESSURE LOSS WARNING

43592

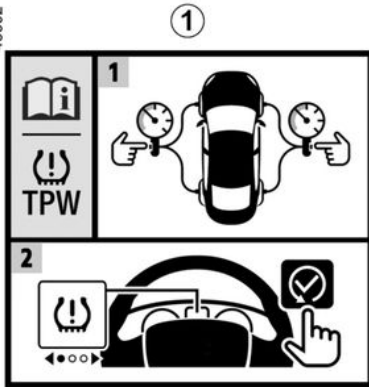

The system can be identified by the **1** label in the vehicle.

Operating principle

64040



62694

When fitted to the vehicle, this system notifies the driver if one or more tyres lose pressure.

66502



3

This system detects a loss of pressure in one of the tyres by measuring the wheel speed while driving.

Warning light  **2** comes on steady to alert the driver in the event of insufficient pressure (deflated wheel, punctured tyre, etc.).

TYRE PRESSURE LOSS WARNING



This function is an additional driving aid.

The function does not take the place of the driver. It cannot, therefore, under any circumstances replace the vigilance or the responsibility of the driver. Check the tyre pressures, including the emergency spare wheel, once a month.

Operating conditions

In order to provide a reliable warning in the event of pressure loss, the system must be reset with an inflation pressure equal to one of those shown on the tyre inflation pressure label (reference values) → 323.

Resetting should always be carried out after checking the tyre pressure of all four tyres when cold.

In the following situations, the system risk coming into action late or not functioning correctly:

- system not reset after reinflation or any operation on the wheels;
- incorrectly reset system: tyre pressures different from the recommended pressures;

- significant change in load or distribution of load on one side of the vehicle;
- sporty driving with strong acceleration;
- driving on snowy or slippery surface;
- driving with snow chains;
- fitting a single new tyre;
- use of tyres not approved by the network.



The tyre pressure must be checked before starting the resetting procedure. The system will not issue a warning if the pressure does not correspond to the recommended pressure.



The sudden loss of pressure in a tyre (burst tyre, etc.) cannot be immediately detected by the system.

Procedure for resetting the standard levels for the tyre pressures

This should be performed:

- after each re-inflation or resetting of tyre pressure;
- after changing a wheel;

- after changing wheels around.

Tyre pressures must correspond to the current usage of the vehicle (empty, carrying a load, motorway driving, etc.). Respect the tyre pressures (including the emergency spare wheel). Check them at least once a month and before every long journey (refer to the label on the edge of the driver's door → 323).

Resetting procedure via the multimedia screen 3



The resetting procedure must be carried out while the vehicle is stationary and the ignition is switched on. Please refer to the multimedia instructions for further information.

TYRE PRESSURE LOSS WARNING



For your safety, the warning light **STOP** requires you to stop immediately as soon as traffic conditions allow.

Readjustment of tyre pressures

The pressure of the four tyres must be set when cold (refer to the label located on the edge of the driver's door).

If tyre pressures cannot be checked when the tyres are **cold**, the **recommended pressures should be increased by 0.2 to 0.3 bar (3 PSI)**.

Never deflate a hot tyre.

After each reinflation or readjustment of the tyre pressure, launch the resetting of the tyre pressure reference value.

Replacing wheels/tyres

Only use equipment approved by the brand network, otherwise the system risks late activation or incorrect operation → **321**.

After each change of wheel/tyre, readjust the tyre pressure and launch the reset of the tyre pressure reference value.

Emergency spare wheel

If fitted on the vehicle, readjust the tyre pressure and launch the resetting of the tyre pressure reference value.

Tyre repair product and inflation kit

Only use equipment approved by the brand network, otherwise there is risk of the system being activated late or not working correctly → **324**. After using the tyre inflation kit, readjust the tyre pressure and launch the resetting of the tyre pressure reference value.

Tyre pressure faults







The table lists the warning messages which appear on the instrument panel **4** when the system detects a tyre pressure fault.

The information on the instrument panel signals any potential tyre pressure faults (e.g. deflated or punctured tyre).

TYRE PRESSURE LOSS WARNING

Fault message table

Indicator lights	Messages	Readings
 comes on	Inflate tyres and init.	This indicates that tyre under-inflation or puncture has been detected. Check and adjust the pressure of the four tyres when cold and reset the system.
 flashes, then stays on	Check tyre press and init.	This indicates that the reset has been unsuccessful. Check and readjust the tyre pressure before re-launching the resetting procedure.
 flashes, then stays on, along with the warning light 	Check TPW	This indicates a fault in the system. Consult an approved dealer.
 flashes, then stays on	TPW not available	This indicates that an emergency spare wheel different in size to the other four wheels has been fitted to the vehicle. The system remains unavailable until a wheel identical in size to the other wheels has been fitted and the resetting procedure has been carried out.

DRIVER CORRECTION DEVICES AND AIDS

Depending on the vehicle, they may include:

- **an anti-lock braking system (ABS);**
- **electronic stability control (ESC) with understeer control and traction control;**
- **emergency brake assist;**
- **multi-collision braking;**
- **regenerative braking system;**
- **hill start assistance.**



These functions are an additional aid in the event of critical driving conditions, enabling the vehicle behaviour to be adapted to suit the driving conditions. These functions do not take the place of the driver. **They do not increase the vehicle's limits and should not encourage you to drive more quickly.** Therefore, they can under no circumstances replace the vigilance or responsibility of the driver when manoeuvring the vehicle (the driver must always be ready for sudden incidents which may occur when driving).

Anti-lock braking system (ABS)

Under heavy braking, the ABS prevents the wheels from locking, allowing the stopping distance to be managed and keeping control of the vehicle.

Under these circumstances, the vehicle can be steered to avoid an obstacle whilst braking. In addition, this system can increase stopping distances, particularly on roads with low surface grip (wet ground etc.).



You will feel a pulsation through the brake pedal each time the system is activated. The ABS does not in any way improve the vehicle's "physical" performance relating to the road surface and roadholding. It is still **essential** to follow the rules of good driving practice (such as driving at a safe distance from the vehicle in front etc.).



In an emergency, apply **firm and continuous pressure** to the brake pedal.

There is no need to pump it repeatedly. The ABS will modulate the force applied in the braking system.

Operating faults:

–  and  illuminated on the instrument panel accompanied, depending on the vehicle, by the "Check ABS", "Check braking system" and "Check ESC" messages to indicate that ABS, ESC and Emergency Brake Assist are deactivated. **Braking is still provided;**

– , ,  and

STOP light up on the instrument panel, accompanied by the "Braking system fault" message **to indicate a fault in the braking system.**

In both cases, please contact an approved Dealer.



Your braking systems are partially operational. However, it is **dangerous to brake suddenly** and it is essential to stop immediately, as soon as traffic conditions allow. Call an approved dealer.

Electronic stability program (ESC) with understeer control and traction control

Electronic stability control ESC

DRIVER CORRECTION DEVICES AND AIDS

This system helps you to keep control of the vehicle in critical driving conditions (avoiding an obstacle, loss of grip on a bend, etc.).

Operating principle

A sensor in the steering wheel detects the direction selected by the driver.

Other sensors throughout the vehicle measure the actual direction.

The system compares the direction selected by the driver and the actual direction of the vehicle and corrects this as necessary by applying the brakes selectively and/or acting on the engine power. If the system is triggered, the



warning light flashes on the instrument panel.

Understeer control

This system optimises the action of the ESC in the case of pronounced understeering (loss of front axle road holding).

Traction control

This system helps to limit wheelspin of the drive wheels and to control the vehicle when pulling away accelerating or decelerating.

Operating principle

Using the wheel sensors, the system measures and compares the speed of the drive wheels at all times and slows

down their over-rotation. If a wheel is starting to slip, the system brakes automatically until the drive supplied becomes compatible with the level of grip under the wheel again.

The system also adjusts the engine speed to the grip available under the wheels, independently of the pressure exerted on the accelerator pedal.

In some situations (driving on very soft ground such as snow or mud, or driving with snow chains fitted), the system may reduce the engine power to limit wheelspin.

Operating faults

When the system detects an operating fault, the message "Check ESC" and

the warning lights  and 

appear on the instrument panel. In this case, the ESC and the traction control system are deactivated.

Consult an approved dealer.

Emergency brake assist

This system supplements the ABS and helps reduce vehicle stopping distances.

Operating principle

The system is for detecting an emergency braking situation. In this case, the braking system immediately devel-

ops maximum power and may trigger ABS control.

ABS braking is maintained as long as the brake pedal is applied.

Brake lights come on

Depending on the vehicle, these may flash in the event of sudden deceleration.

Braking anticipation

Depending on the vehicle, when you rapidly release the accelerator, the system anticipates the braking manoeuvre in order to reduce stopping distances.

Special cases

When using the cruise control:

- if you use the accelerator pedal when you release it, the system may be triggered;
- if you do not use the accelerator, the system will not be triggered.

Operating faults

When the system detects an operating fault, the "Check braking system" message is displayed on the instrument

panel accompanied by the 

Consult an approved dealer.

DRIVER CORRECTION DEVICES AND AIDS

Multi-collision braking

Multi-collision braking reduces the risk of an additional collision after an accident by temporarily bringing your vehicle to a standstill.

Operating principle

When the airbag system detects a collision, the pretensioners or airbags are triggered → 60 and the "Multi-collision braking" function activates the Electronic Stability Program (ESC) to brake the vehicle.

Multi-collision braking is deactivated during operation if:

- the driver presses the accelerator pedal firmly;
- and/or
- the braking force generated by the driver pressing the brake pedal is greater than the force produced by the automatic braking triggered by the function.

Note: multi-collision braking requires the proper functioning of your vehicle's braking system.

Operating faults

When the system detects an operating fault, the message "Check Post-collision" and the warning light  appears on the instrument panel.

In this case, the function is deactivated. Consult an approved dealer.

Regenerative braking system

When braking, the regenerative braking system can convert the energy produced by the vehicle deceleration into electric energy.

This will recharge the traction battery and extend the vehicle range.

Operating faults

-  lit on the instrument panel, accompanied by the "WARNING: Check Braking System" message: **braking assistance is still operational.**

Under these conditions, the feel of applying the brake pedal may be different.

You are recommended to apply strong continuous pressure to the pedal.

Consult an approved dealer.

-  lit on the instrument panel, accompanied by the "WARNING: Braking System" message: **this indicates a fault with the braking system.**

Call an approved dealer.



For your own safety, the  warning light requires you to stop immediately, as soon as traffic conditions allow. Switch off the engine and do not restart it. Call an approved dealer.

Hill start assistance

Depending on the gradient of the incline, this system assists the driver when starting on a hill. It prevents the vehicle from rolling backwards by automatically applying the brakes when the driver lifts his/her foot off the brake pedal to depress the accelerator pedal.

System operation

It only operates when the gear lever is in a position other than neutral (other than N or P for automatic transmissions) and the vehicle is completely stationary (brake pedal depressed).

The system holds the vehicle for approximately **2 seconds**. The brakes are then gradually released (the vehicle will move according to the slope).

DRIVER CORRECTION DEVICES AND AIDS



The hill start assistance system cannot completely prevent the vehicle from rolling backwards in

all situations (extremely steep gradients etc.).

In all cases, the driver may depress the brake pedal to prevent the vehicle from rolling backwards.

The Hill Start Assist function should not be used for prolonged stops: use the brake pedal.

This function is not designed to immobilise the vehicle permanently.

If necessary, use the brake pedal to stop the vehicle.

The driver must remain particularly vigilant when driving on slippery or low-grip surfaces.

Risk of serious injury.

3

ADDITIONAL DRIVING AID FUNCTIONS

My Safety

The "My Safety" function can be used to deactivate or activate a set of driver assistance functions simultaneously.

Depending on the vehicle, you can configure the "My Safety" function from the multimedia screen by selecting the driving aid functions to be switched off as a group.

Operation



"All on" mode

Depending on the vehicle, the functions and configurations of driving assistance concerned are:

- overspeed sound alert → 204;
- lane departure prevention → 172;
- driver vigilance warning → 202;
- emergency lane departure prevention → 179.

When the "All ON" mode is activated: the indicator light on the button 1 lights up and the "My Safety All ON selected" message is displayed on the instrument panel to confirm this. The driving aids that are available in the mode are activated.

"Custom" mode

You can use this mode to **deactivate** or **reactivate** certain driving aids that are available in the "All ON" mode previously configured using the "MY SAFETY PERSO" setting.

With the ignition on, press the switch 1 twice in quick succession. On the first press, the "Press again for My Safety Custom" message is displayed on the instrument panel. On the second press, the warning light on the switch 1 goes out. The "Custom" mode is activated. The "My Safety Perso selected" message is displayed on the instrument panel.

To switch back to "All ON" mode, **press once** on the button 1. The indicator light on the button 1 lights up.



Depending on the length of time following the last time the engine was stopped, the alerts are reactivated:

- when the vehicle is unlocked;
- or
- when a door is opened;
- or
- when the engine is restarted.

Perso mode configuration

From the multimedia screen 2



ADDITIONAL DRIVING AID FUNCTIONS

Refer to the multimedia instructions for information on accessing the settings.

Lane departure prevention



Using information from the **1** camera, the function triggers corrective action on the vehicle steering system when a continuous or broken line is crossed or when approaching the roadside (divider, barrier, pavement, embankment, etc.) without activating the direction indicator lights.

Depending on the setting, in the event of crossing a broken line without activating the direction indicator lights, the function:

- warns the driver without corrective action on the steering system;

or

- performs corrective action on the steering system.

 You can **retake control of the vehicle** at any time by operating the steering wheel.

Location of camera 1

Make sure the windscreen is not obscured (by dirt, mud, snow, condensation etc.).



This function is an additional driving aid. This function is not under any circumstances intended to replace the due care and attention of the driver, who should at all times be in control of the vehicle.

Activation/deactivation

From the multimedia screen 2



Please refer to the multimedia instructions for more information.

ADDITIONAL DRIVING AID FUNCTIONS

From the "My Safety" switch 3



– **To deactivate the function**, if it has been deactivated from the "Custom" mode of the "My Safety" → 171func-

tion, press switch 3 twice. The warning light is displayed in yellow on the instrument panel.

– **To reactivate the function**, press

the 3 switch once. Warning light comes on the instrument panel.

Operation



When the function is activated, the

warning light or the left-hand and right-hand line indicators 4 are displayed in grey on the instrument panel.

The function is ready to alert or intervene if the vehicle speed is over approximately 40 mph (65 km/h) and

the warning light or the left-hand or right-hand line indicators 4 are displayed in white.

The function is in operation if the vehicle

– approaches a roadside without activating direction indicators;

- crosses a continuous line without activating the indicator lights;
- crosses a broken line without activating the direction indicators, if the "operation on broken line" setting is selected.

In these cases:

– the function triggers an action on the vehicle's steering system to correct the vehicle trajectory;

– the warning light and the indicator 4 on the side of the breached line changes to yellow on the instrument panel.

If the corrective action on the steering

system is not sufficient, the warning light or

the warning light and the indicator 4 on the side of the breached line change to red on the instrument panel, accompanied by a vibration on the steering wheel.



When the "Operation on broken line" setting is not selected, **the function sounds the alarm** if the vehicle crosses a broken line without activating the indicator lights, and there is no roadside close enough to the line.

In this case, the function warns the driver:

– by a vibration in the steering wheel;

ADDITIONAL DRIVING AID FUNCTIONS

and

– the  or  warning light and the indicator 4 on the side of the breached line turns to red on the instrument panel.

Note: on bends, the function allows for slightly cutting the bend.

Special cases

"Keep control" Warning

– If the system is operating and does not detect any activity on the steering wheel, the "Keep control" message appears on the instrument panel accompanied by a beep and, depending on

the vehicle, the  warning light appears in yellow until the driver has regained control of the vehicle.

– If the system has been in operation for too long, the "Keep control" message appears on the instrument panel accompanied by a beep and depend-

ing on the vehicle, the  warning light appears in yellow accompanied by the indicator 4 on the side of the line concerned until the driver has regained control of the vehicle.



You can interrupt the trajectory correction at any time by moving the steering wheel.

Vehicle fitted with "Active driver assist" system

If the "Lane centring" function is activated at the same time as the "Lane departure prevention" function, the display of the warning light will vary as follows:

– the "Lane Centring" function is in op-



eration: the green  warning light

replaces the white or grey  or

 warning light on the instrument panel. Thus, you are informed as a priority of the status of the function "Channel centring";



– the "Lane Centring" function is put on standby and the "Lane Departure Prevention" function is neither ready

nor in operation: the grey  warning light replaces the white or grey

 or  warning light on the instrument panel. Thus, you are in-

formed as a priority of the status of the function "Channel centring";

– the "Lane Centring" function is put on standby while the "Lane Departure Prevention" function is ready or in op-

eration: the  or  warning light is displayed in red or in yellow on the instrument panel. Thus, you are informed as a priority of the status of the function "Lane departure prevention".

In any case, you are informed at all times of the status of the function when it controls the steering system of your vehicle. The most useful information is always displayed.

Function temporarily unavailable/disabled

The system is temporarily unavailable or disabled when:

- very fast lane departure;
- driving continuously on a line;
- approximately four seconds after changing lanes;
- tight bends;
- impaired visibility;
- one of the direction indicators is activated;
- activating the hazard warning lights;
- engaging reverse gear;
- strong acceleration;
- the vehicle speed is greater than approximately 99 mph or 112 mph

ADDITIONAL DRIVING AID FUNCTIONS

(160 km/h or 180 km/h), depending on the vehicle;

- the lane width changes;
- operation of the electronic stability control (ESC);
- operation of the anti-lock braking system;
- the active emergency braking system is triggered;
- intervention of another function that controls the steering system, such as the "Lane Centring" function.

If the function is unavailable, the  warning light and the left-hand and right-hand correction indicators **4** appear in grey on the instrument panel.

or  warning light and the left-hand and right-hand correction indicators **4** appear in grey on the instrument panel.

If the front camera is obscured, the "Front camera without visibility" message is displayed on the instrument panel. Clean the area where the sensors are located

Automatic deactivation

The function is automatically deactivated when:

- the electronic stability control (ESC) is deactivated or malfunctions;
- the anti-lock braking system is malfunctioning;
- a towbar is electrically connected to the trailer hitch socket;

– the  warning light is displayed.

When the function is deactivated, the

 warning light is displayed in yellow on the instrument panel.

Settings



To access the multimedia screen function settings **2**, refer to the multimedia instructions:

- "Operation on broken line": use this setting to select the response of the function if the vehicle crosses a broken line without activating the direction indicators:
 - selected setting: the function may trigger an action on the vehicle's

steering system to correct the vehicle trajectory;

– setting not selected: the function can warn the driver by means of a vibration at the steering wheel without correcting the vehicle trajectory.

– "Vibration": adjust the steering wheel vibration for the "Lane departure prevention" function;

– "Lane exit anticipation": adjust the line detection sensitivity level. To do this, select:

- "Late": line detected upon crossing;
- "Standard": line detected on approach;
- "Early" line detected nearby.

Please refer to the multimedia instructions for further information.

Operating faults

When the system detects an operating fault, the left-hand and right-hand line

indicators and the  warning light appear in yellow on the instrument panel.

In some cases, they are accompanied by the following message:

- « Driving assist unavailable » ;
- or
- « Check Front camera » ;

ADDITIONAL DRIVING AID FUNCTIONS

or

– « Check Driving assist ».

Consult an approved dealer.

3

ADDITIONAL DRIVING AID FUNCTIONS

Warnings



This function is an additional driving aid. This function is not under any circumstances intended to replace the due care and attention of the driver, who should at all times be in control of the vehicle.

System servicing/repairs

- In the event of an impact, the camera alignment may be changed, and its operation may consequently be affected. Deactivate the function and consult an authorised dealer.
- Any work in the area where the camera is located (repairs, replacements, windscreen modifications etc.) must be carried out by a qualified professional.

Only an authorised dealer is qualified to service the system.

In the event of system disturbance

Some conditions can disturb or damage the system's operation, such as:

- windscreen obscured (by dirt, ice, snow, condensation etc.);
- a complex environment (tunnel, etc.);
- poor weather conditions (snow, rain, hail, black ice, etc.);
- poor visibility (night, fog, etc.);
- the road markings are irregular or difficult to distinguish (e.g. partially erased, excessive spacing, distorted road surface...);
- being dazzled (glaring sun, lights of vehicles travelling in the opposite direction; etc.);
- the road is narrow, winding or undulating (tight bends, etc.);
- closely following a vehicle travelling in the same lane.

In this case, the "Lane Departure Prevention" function may be activated incorrectly or not at all.

Risk of unwanted, incorrect correction or no correction of trajectory.

Deactivating the function

You must deactivate the function if:

- the area of the camera has been damaged (on the windscreen side or the interior rear-view mirror side);
- the road is slippery (snow, black ice, aquaplaning, gravel etc.);
- poor visibility (night, fog, etc.);

ADDITIONAL DRIVING AID FUNCTIONS

- the windscreen is cracked or distorted (do not carry out windscreen repairs in this area; have it changed by an approved dealer);
- the vehicle is towing a trailer or a caravan;
- the vehicle is entering an area with several surface markings (an area with road works etc.).

3

ADDITIONAL DRIVING AID FUNCTIONS

Emergency lane departure prevention



Using information from the radar **2** and the camera **1**, the function triggers corrective action on the vehicle steering system in the event of a risk of collision with a vehicle coming from the opposite direction in the adjacent lane, without the direction indicator having been activated.

Depending on the vehicle, using information from the radars **3** and the camera **1**, the function triggers corrective action on the vehicle steering system in the event of a risk of collision with a vehicle moving at the same speed or at a higher speed, if within the detection area of the rear radars.

 You can **retake control of the vehicle** at any time by operating the steering wheel.



This system provides an additional driving aid. This system is not, under any circumstances, intended to replace the due care and attention of the driver, who should at all times be in control of the vehicle.

Location of the camera **1**

Make sure the windscreen is not obscured (by dirt, mud, snow, condensation etc.).

Location of the front radar **2**

Ensure that the radar area is not obstructed (dirt, mud, snow, a badly fitted/attached front number plate), impacted, modified (including paintwork) or hidden by any accessory fitted on the front of the vehicle (on the front bumper, logo, etc.)

Location of the side radars **3**

Ensure that the radar area is not obstructed (by dirt, mud, snow etc.), impacted or modified (including paintwork etc.).

ADDITIONAL DRIVING AID FUNCTIONS

Activating/deactivating the function

From the **A** "My Safety" switch



Press switch **A** twice if the function has been disabled from the "Custom" mode of the "My Safety" function → 171.

To reactivate the function, press the **A** switch.

From the **B multimedia screen**



Please refer to the multimedia instructions for more information.

Detection of an oncoming vehicle

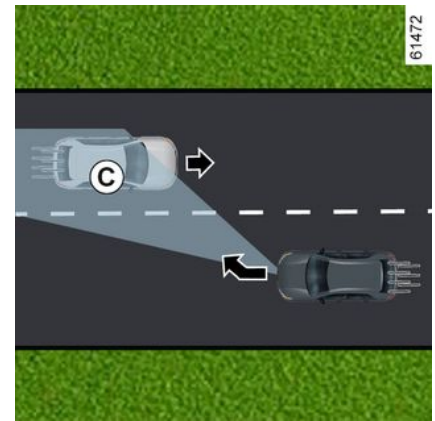
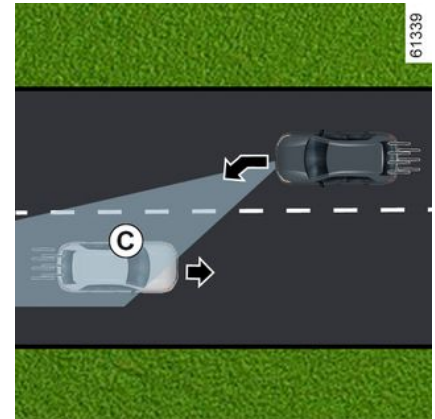

When driving at a speed between approximately 40 mph (65 km/h) and 68

ADDITIONAL DRIVING AID FUNCTIONS

mph (110 km/h), if there is a risk of collision with a vehicle coming from the opposite direction in an adjacent lane and within the detection zone **C**, without the direction indicator having been activated, the system:

- **warns you of a collision risk:**

66503

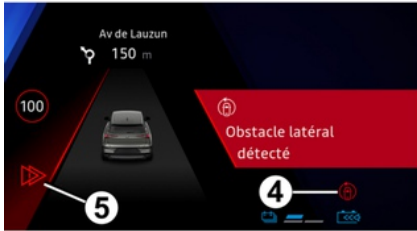

The message "Risk of collision" is displayed on the dashboard accompanied by the indicator **4** in red, the line on the side of the intervention and an audible signal. Display **5** appears on the instrument panel on the side of the intervention;

and

- **triggers corrective action on the steering system.**



You can interrupt the trajectory correction at any time by moving the steering wheel.



This function is an additional driving aid. This function is not under any circumstances intended to replace the due care and attention of the driver, who should at all times be in control of the vehicle.

The function may not activate if the approaching speed is greater than approximately 124 mph (200 km/h) (for example, you are travelling at 68 mph (110 km/h) and the vehicle is travelling in the opposite direction in the adjacent lane at 56 mph (91 km/h)).

If case of overtaking

(depending on the vehicle)

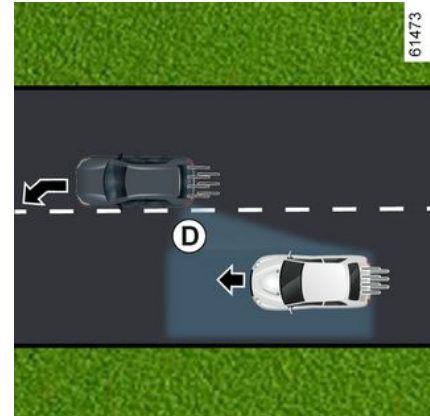

61473

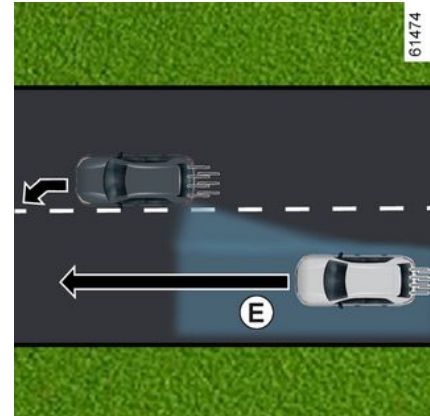

61474

ADDITIONAL DRIVING AID FUNCTIONS

3



66503

risk of collision with a vehicle located in the blind spot **D** and it is moving in the same direction as your vehicle or with a vehicle that is rapidly approaching from behind in an adjacent lane that is in the detection area **E**, the system:

- **warns you about a risk of collision:** the warning light **6** flashes, the message "Lateral obstacle detected" is displayed on the instrument panel, accompanied by the indicator **4** in red, the line on the side of the intervention and an audible signal. Display **5** appears on the instrument panel on the side of the intervention;

and

- **triggers corrective action on the steering system.**

Temporarily not available / non-activation of the system

The system is temporarily unavailable or disabled when:

- very fast lane departure;
- driving continuously on a line;
- approximately four seconds after changing lanes;
- tight bends;
- impaired visibility;
- activation of the direction indicator light (only when an oncoming vehicle is detected in an adjacent lane);

- activating the hazard warning lights;
- strong acceleration;
- the vehicle speed is greater than approximately 99 mph or 112 mph (160 km/h or 180 km/h), depending on the vehicle;
- the lane width changes;
- operation of the electronic stability control (ESC);
- operation of the anti-lock braking system;
- operation of the active emergency braking system;
- ...

The system cannot be activated when:

- the camera does not detect a line (solid or broken) on the relevant side of the vehicle;
- the camera does not simultaneously detect the two boundaries of the lane in which your vehicle is moving;
- reverse gear is engaged;
- the field of vision of the camera is obstructed;
- the front radar is obscured;
- depending on the vehicle, the rear radars are obscured;
- ...

Depending on the vehicle, if one of the side radars is obscured the message "Side radars no visibility" will appear on the instrument panel.



62717

While driving at a speed over 40 mph (65 km/h), when approaching a line (continuous or broken) and there is a

ADDITIONAL DRIVING AID FUNCTIONS

When the front radar is obscured, the "Front radar no visibility" message is displayed on the instrument panel.

When the front camera is obscured, the "Front camera no visibility" message is displayed on the instrument panel.

Clean the area where the sensors are located.

Automatically deactivating the function

The system is automatically deactivated when:

- the electronic stability control (ESC) is deactivated or malfunctions;
- the anti-lock braking system is malfunctioning;
- A towbar is electrically connected to the trailer hitch socket;

– the **STOP** warning light is displayed.

If the vehicle is equipped with a towbar that is recognised by the system, the message "Trailer: side radars unavailable" is displayed to inform you that the emergency lane departure prevention function has been deactivated.

If the vehicle is towing a trailer or caravan, unexpected or unnecessary corrections may occur. You can deactivate the system to avoid unexpected or unnecessary corrections.

Operating faults

When the function detects an operating fault, the following messages may be displayed on the instrument panel:

– « Check Front camera » ;

or

– « Front radar to check » ;

or

– « Check Driving assist » ;

or, depending on the vehicle,

– « Check Side radars ».

Consult an approved Dealer.

ADDITIONAL DRIVING AID FUNCTIONS

Warnings



This function is an additional driving aid. This function is not under any circumstances intended to replace the due care and attention of the driver, who should at all times be in control of the vehicle.

System servicing/repairs

- In the event of an impact, the alignment of the camera or radar(s) may be altered and its operation may consequently be affected. Deactivate the function and consult an authorised dealer.
- Any work in the area where the camera or radars are located (replacements, repairs, windscreen modifications etc.) must be carried out by a qualified professional.

Only an authorised dealer is qualified to service the system.

In the event of system disturbance

Some conditions can disturb or damage the system's operation, such as:

- windscreen obscured (by dirt, ice, snow, condensation etc.);
- a complex environment (tunnel, etc.);
- poor weather conditions (snow, rain, hail, black ice, etc.);
- poor visibility (night, fog, etc.);
- the road markings are irregular or difficult to distinguish (e.g. partially erased, excessive spacing, distorted road surface...);
- being dazzled (glaring sun, lights of vehicles travelling in the opposite direction; etc.);
- the road is narrow, winding or undulating (tight bends, etc.);
- closely following a vehicle travelling in the same lane.

In this case, the "lane departure prevention" function may be activated incorrectly or not at all.

Risk of unwanted, incorrect correction or no correction of trajectory.

Deactivating the function

You must deactivate the function if:

- the camera area (on the windscreen side or the interior rear-view mirror side) or radar area(s) have been damaged;
- the road is slippery (snow, black ice, aquaplaning, gravel etc.) ;
- poor visibility (night, fog etc.) ;

ADDITIONAL DRIVING AID FUNCTIONS

- the windscreen is cracked or distorted (do not carry out windscreen repairs in this area; have it changed by an approved dealer);
- the vehicle is towing a trailer or a caravan;
- the vehicle is being towed (breakdowns);
- the vehicle is entering an area with several surface markings (an area with road works etc.) ;
- you are not driving on a paved road.

ADDITIONAL DRIVING AID FUNCTIONS

Blind spot warning

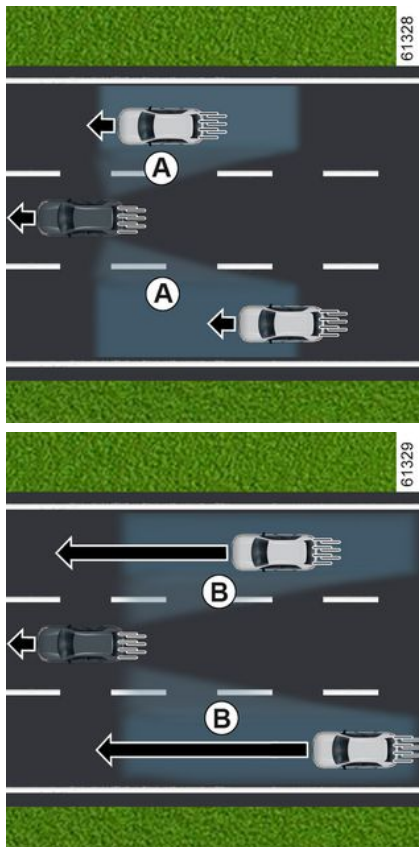

Using information from the sensors installed on each side of the rear bumper (area **C**), the function warns the driver:

- when a vehicle is in the blind spot area **A** and travelling in the same direction as your vehicle;
- and/or
- when there is a risk of collision with a vehicle that is in the **B** area and driving faster than you on an adjoining lane.

The function warns you when your vehicle is travelling at a speed above approximately 9 mph (15 km/h).



The function does not notify the driver if the other vehicles are not moving.



This function is an additional driving aid. This function is not under any circumstances intended to replace the due care and attention of the driver, who should at all times be in control of the vehicle.

Special feature



ADDITIONAL DRIVING AID FUNCTIONS

Ensure that zone **C** around the radars on each side of the rear bumper are not obstructed (by dirt, mud, snow, etc.).

If one of the radars is obscured, the "Side radars without visibility" message is displayed on the instrument panel. Clean the area where the sensors are located.

Warning light 2



A warning light **2** is located on each door mirror **3**.

Note:

– clean the **3** rear view mirrors regularly, so that the indicator lights **2** can be seen properly;

– if you overtake another vehicle, the warning light **2** will only come on, if that vehicle remains for a long enough period in your vehicle's blind spot area **A**.

Display D

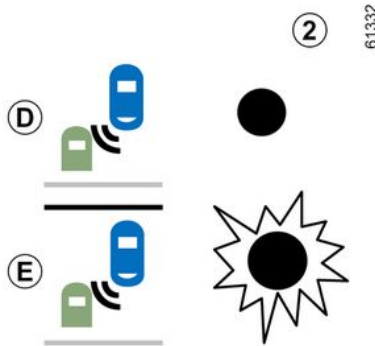

First warning: **direction indicator not activated**, the warning light **2** indicates that a vehicle is detected in the blind spot area and/or that a vehicle is rapidly approaching from the rear in an adjacent lane.

Display E

Direction indicator activated, the **2** warning light flashes when the function detects a vehicle in the blind spot

warning area and/or a vehicle is rapidly approaching from the rear on the side towards which you will turn the wheel. If you cancel the direction indicator, the function will return to the initial warning (display **D**).

Conditions for non-function

– When driving on a road with tight bends;
– in reverse.

If the vehicle is equipped with a towbar recognised by the system, the "Trailer: blind spot warning off" message is displayed on the instrument panel to inform you that the function is not operational. For information on the range of equipment adapted to your vehicle, we advise you to consult an approved Dealer.

Operating faults

If the system detects a fault, the "Check Side radars" message is displayed on the instrument panel.

Consult an approved dealer.

ADDITIONAL DRIVING AID FUNCTIONS



Due to the presence of sensors behind the bumper, it is advisable to entrust any operation on the bumper (repair, replacement, paintwork, etc.) to a qualified professional.

3

ADDITIONAL DRIVING AID FUNCTIONS

Warnings



- The system's detection range operates according to a standard lane width. If driving on a narrow lane, the system may warn you when a vehicle is detected further away than the nearest lane.
- The system's detection range operates according to a standard lane width. If you are driving in wide traffic lanes, the system might not be able to detect a vehicle in the blind spot.
- In the event of very bad weather conditions (heavy rain, snow, etc.), the system may be temporarily disrupted. Remain aware of driving conditions.

There is a risk of accidents.

ADDITIONAL DRIVING AID FUNCTIONS



This function is an additional driving aid. This function is not under any circumstances intended to replace the due care and attention of the driver, who should at all times be in control of the vehicle.

The driver should always adapt their speed to the traffic conditions, regardless of the system indications.

The system should under no circumstances be taken to be an obstacle detector or an anti-collision system.

System servicing/repairs

- In the event of an impact, radar alignment may be changed, and its operation will consequently be affected. Consult an approved dealer.
- Any work in the area where the radars are located (repairs, replacements, etc.) must be carried out by a qualified professional.

Only an authorised dealer is qualified to service the system.

System disturbance

Some conditions can disturb or damage the system's operation, such as:

- complex surroundings (metal bridges, tunnels, roads with barriers at the edge, etc.);
- poor weather conditions (snow, hail, black ice etc.) ;
- the vehicle is fitted with a towbar that is not recognised by the system.

Risk of false alarms or absence of warnings

If the system behaves abnormally contact an authorised dealer.

ADDITIONAL DRIVING AID FUNCTIONS



Limitation of the system operation

- The radar area should be kept clean and free of any modifications in order to ensure the proper operation of the system.
- Small objects moving close to the vehicle (motorcycles, bicycles, pedestrians, etc.) may not be recognised by the system.
- When turning into a bend, the radars may temporarily cease to detect vehicles in adjacent lanes.
- The function may warn you late when two other vehicles are approaching from the rear, side by side in the adjacent lanes (driving on a 3-lane road) and at a much higher speed than your vehicle.
- The system may not provide a warning when the other vehicles are travelling at a significantly different speed.
- If the vehicle is being overtaken by a long vehicle (e.g. heavy goods vehicle overtaking at a similar speed to the vehicle) the system may interrupt the warning before the end of the manoeuvre.
- The vehicle is travelling on a winding road.

ADDITIONAL DRIVING AID FUNCTIONS

Safe distance alert



Using the information from the radar **2** and camera **1**, this function informs the driver of the time interval between their vehicle and the vehicle in front so that a safe stopping distance between the two vehicles can be maintained.

The function is active from the approximately 19 mph (30 km/h).



This function is an additional driving aid. This function is not under any circumstances intended to replace the due care and attention of the driver, who should at all times be in control of the vehicle.

Location of camera 1

Make sure the windscreen is not obscured (by dirt, mud, snow, condensation etc.).

Location of the radar 2

Ensure that the radar area is not obstructed (by dirt, mud, snow, a badly fitted front number plate etc.), impacted, modified (including painting) or hidden by any accessory fitted on the front of the vehicle (on the grille or logo etc.).

Activating/deactivating the function



From the "Vehicle" world on your multimedia screen **3**, press the "Driving assistance" menu.

Activate or deactivate the "Following distance" function.



Each time the vehicle is started, the function continues the mode saved the last time the engine was stopped.

ADDITIONAL DRIVING AID FUNCTIONS

Operation

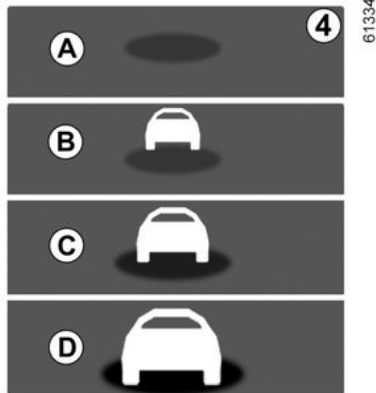

With the function activated, the **4** indicator is displayed on the instrument panel and informs the driver of the distance between their vehicle and the vehicle in front.

- **A** (grey): function not operational;
- **A** (green): no vehicle detected;
- **B** (green): the time interval is greater than or equal to around two seconds (distance between the two vehicles adapted to your speed);
- **C** (orange): the time interval falls between around 1 and 2 seconds (insufficient distance between the two vehicles);
- **D** (red): the time interval is less than or equal to around one second

(very insufficient distance between the two vehicles).

If the interval between the two vehicles is less than approximately 0.5 seconds, the indicator light **4** and display **D** will flash in red on the instrument panel along with "-.- s".

Under certain conditions, the time interval may not be displayed:

- while cornering;
- when changing lane;
- if the vehicle in front is sufficiently far or outside the range of the radar or camera.



The measurement is displayed for information: the system does not carry out any action on the

vehicle.

This function is not designed for use in urban conditions or for a dynamic driving style (sudden cornering, acceleration, braking, etc.), but rather for stable driving conditions.

The function does not interact with the braking system.

The radar and camera zones must be kept clean and free of any tampering in order to ensure the proper operation of the system.

Any work carried out in the area where the radar or camera is located (repairs, replacements, windscreen and/or bumper modifications, etc.) must be carried out by a qualified professional.

ADDITIONAL DRIVING AID FUNCTIONS

Warnings



This function is an additional driving aid. This function is not under any circumstances intended to replace the due care and attention of the driver, who should at all times be in control of the vehicle.

System servicing/repairs

- In the event of an impact, the radar and/or camera alignment may be changed and its operation may consequently be affected. Deactivate the function and consult an authorised dealer.
- Any work carried out in the area where the radar and/or camera is located (replacements, repairs, windscreen and/or bumper modifications, etc.) must be carried out by a qualified professional.

Only an authorised dealer is qualified to service the system.

In the event of system disturbance

- obstruction of the windscreen or the bumper (by dirt, ice, snow, condensation etc.);
- a complex environment (metal bridge, tunnel, etc.);
- poor weather conditions (snow, hail, black ice, etc.);
- poor visibility (night, fog, etc.);
- poor contrast between the vehicle preceding it and the surrounding area (e.g. white vehicle in a snowy area, etc.);
- being dazzled (glaring sun, lights of vehicles travelling in the opposite direction; etc.);
- the road is narrow, winding and undulating (tight bends etc.)

Risk of erroneous false alarms.

3

ADDITIONAL DRIVING AID FUNCTIONS

Active emergency braking



Using information from the camera **1** and the radar **2**, the system determines the distance between your vehicle:

- from the vehicle ahead in the same lane;

or

- from any oncoming vehicles in the context of a manoeuvre to change direction;

or

- and vehicles passing perpendicularly;

or

- and stationary vehicles;

or

- surrounding pedestrians and cyclists.

The system informs the driver if there is a risk of head-on collision to enable appropriate emergency manoeuvres (pressing the brake pedal and/or turning the steering wheel).

Depending on the reactivity of the driver, the system can assist with braking in order to limit damage or prevent a collision.

The system is otherwise inactive and does not trigger an alert.



This function is an additional driving aid.

This function is not under any circumstances intended to replace the due care and attention of the driver, who should at all times be in control of the vehicle.



This system can apply maximum braking to the vehicle until it is completely stationary if necessary.

For safety reasons, always wear your seat belt when travelling in your vehicle and make sure that it is loaded so that no items can be thrown forward and hit the occupants.

Location of the camera **1**

Make sure the windscreen is not obscured (by dirt, mud, snow, condensation etc.).

Location of the radar **2**

Make sure that the area around the radar is not obscured (by dirt, mud, snow or an incorrectly fitted number plate), impacted, altered (including paintwork) or hidden.

ADDITIONAL DRIVING AID FUNCTIONS

Operation

66504



When driving, when there is a risk of collision, the system:

– **alerts you of a collision risk:** the "Detected obstacle" message appears on the instrument panel accompanied by a beep.

Note: if the driver presses the brake pedal and the system still detects a risk of collision, the braking force may be increased if it is not sufficient to prevent the collision.

– **can trigger braking:** if the driver does not react to the alert and the collision becomes imminent, the red 

warning light or, depending on the vehicle, the symbol **3** and the "Brake"

message appear on the instrument panel accompanied by a beep.

Note:

- if the driver uses the vehicle controls (steering wheel, pedals, etc.) the system may delay its reaction or not activate;
- if active emergency braking has caused the vehicle to stop, the vehicle is kept stationary for a short time. Beyond this time limit, the driver must keep the vehicle stationary by holding their foot on the brake pedal;
- after the system activates braking, the "Advanced Safety triggered" message will be displayed



In the event of an emergency manoeuvre, you can stop the braking at any moment by:

- tapping the accelerator pedal;
- or
- turning the steering wheel as a collision avoidance manoeuvre.



Special features of warnings

Depending on the speed, the warning and braking may be activated simultaneously.

Vehicle detection

Detection of vehicles travelling in the same lane

A risk of a collision with the vehicle in front of you in the same lane is detectable by the system when the vehicle is travelling at a speed over approximately 5 mph (8 km/h).

Detection of oncoming vehicles in the context of a manoeuvre to change direction

ADDITIONAL DRIVING AID FUNCTIONS

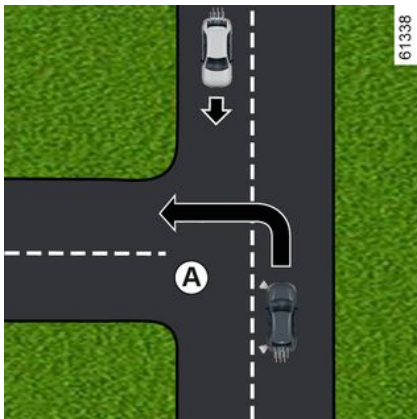

When you wish to change direction (e.g. **A**), oncoming vehicles are detected by the system when:

- your vehicle is travelling at a speed between approximately 5 mph (8 km/h) to 12 mph (20 km/h);
- you have activated the direction indicator light.

Detection of vehicles crossing the lane perpendicularly

Vehicles crossing the lane perpendicularly are detected by the system when:

- your vehicle is travelling at a speed between approximately 12 mph (20 km/h) and 37 mph (60 km/h).

Detection of vehicles stopped in the lane

Stationary vehicles are detected by the system when:

- your vehicle is travelling at a speed between approximately 5 mph (8 km/h) and 50 mph (80 km/h).

Detection of pedestrians and cyclists

Detection of pedestrians and cyclists in the same lane

The system detects pedestrians and cyclists when:

- your vehicle is travelling at a speed between approximately 5 mph (8 km/h) and 53 mph (85 km/h).

Detection of pedestrians and cyclists when changing direction

The system detects pedestrians and cyclists when:

- your vehicle is travelling at a speed between approximately 5 mph (8 km/h) and 12 mph (20 km/h).

Activation/deactivation



Depending on the vehicle, according to the length of time following the last time the engine was stopped, the function is reactivated:

- when the vehicle is unlocked;
- or
- when a door is opened;
- or
- when the engine is restarted.

Activating, deactivating the system from the multimedia screen 4

ADDITIONAL DRIVING AID FUNCTIONS

3



To activate or deactivate the function, refer to the multimedia instructions. Select "ON" or "OFF".

Settings



For safety reasons, carry out any adjustments while the vehicle is stationary.

Settings from the multimedia screen 4



With the vehicle stationary, to access the function settings from the multimedia screen 4, refer to the multimedia instructions:

"Warning anticipation": adjust the alert sensitivity level. To do this select:

- « Late » ;
- « Standard » ;
- « Early ».

Please refer to the multimedia instructions for more information.

Temporarily not available

If the system detects a temporary fault, the  warning light appears, or de-

pending on the vehicle, the 

warning light appears on the instrument panel.

The possible causes are:

- the system is temporarily blinded (glare from the sun, dipped beam headlights, bad weather conditions etc.). The system will be operational again when visibility conditions are better;
- the system is temporarily interrupted (e.g. the windscreen, front or rear bumper or logo is obscured by dirt, mud, snow, condensation, etc.) In this case, park the vehicle and switch off the engine. Clean the windscreen, the front bumper or the logo. The next time the engine is started, after around five or ten minutes of driving, the warning light and the message disappear. If this is not the case, this may arise from another cause; contact an Approved Dealer.

Operating faults

If the system detects a temporary fault the  warning light illuminates, or

depending on the vehicle, the  warning light illuminates on the instrument panel. Consult an approved dealer.

ADDITIONAL DRIVING AID FUNCTIONS

Warnings



This function is an additional driving aid. This function is not under any circumstances intended to replace the due care and attention of the driver, who should at all times be in control of the vehicle. The triggering of this function may be delayed or prevented when the system detects clear signs of control of the vehicle by the driver (action on the steering wheel, pedals etc.).

The system cannot be activated:

- the gear control is in Neutral position;
- when the Electronic Stability Program (ESC) has started.

System servicing/repairs

- In the event of an impact, the radar and/or camera alignment may be changed and its operation may consequently be affected. Deactivate the function and consult an authorised dealer.
 - Any work in the area where the radar and/or camera is located (repairs, replacements, windscreen modifications, etc.) must be carried out by a qualified professional.
- Only an authorised dealer is qualified to service the system.

ADDITIONAL DRIVING AID FUNCTIONS



System disturbance

Some conditions can disturb or damage the system's operation, such as:

- a complex environment (metal bridge, tunnel, etc.);
- poor weather conditions (snow, hail, black ice, etc.);
- poor visibility (night, fog, etc.);
- poor contrast between the object (vehicle, pedestrian etc.) and the surrounding area (e.g. pedestrian dressed in white located in a snowy area etc.);
- being dazzled (glaring sun, lights of vehicles travelling in the opposite direction; etc.);
- windscreen obscured (by dirt, ice, snow, condensation etc.);
- ...

In these conditions, the system may not react, may warn the driver or may brake inadvertently.

Limitation of the system operation

- Each time the vehicle is started, the system carries out a calibration according to the vehicle surroundings and may be inactive for approximately two to five minutes;
- The radar and camera areas must be kept clean and free of any modifications to ensure the proper functioning of the system if the conditions described in the "Special cases of oncoming vehicles when changing direction" are met;
- the system may not respond to small vehicles such as motorbikes as effectively as to other vehicles;
- the system may not operate properly when the road surface is slippery (rain, snow, black ice, etc.);
- to ensure correct operation, the system needs to distinguish the complete outline of the pedestrian. So the system cannot detect:
 - pedestrians in the darkness or in poor lighting conditions;
 - partially visible pedestrians;
 - pedestrians less than approximately 80 cm;
 - pedestrians carrying large objects;
 - ...

In these conditions, the system may not react, may warn the driver or may brake inadvertently.

ADDITIONAL DRIVING AID FUNCTIONS



Deactivating the function

You must deactivate the function if:

- the camera area has been damaged (e.g. on the inside or outside of the windscreen);
- the front of the vehicle was damaged (impact, scratch on the radar, etc.);
- the vehicle is being towed (breakdowns);
- the windscreen is cracked or distorted (do not carry out windscreen repairs in this area; have it changed by an approved dealer);
- you are not driving on a paved road.

In the event of the system behaving abnormally, deactivate it and consult an authorised dealer.

Halting the function

You can halt the active braking function at any time by tapping the accelerator pedal or by turning the steering wheel in a collision avoidance manoeuvre.

ADDITIONAL DRIVING AID FUNCTIONS

Driver vigilance warning

The driver vigilance warning is a function that analyses the behaviour of the driver (driving style, vehicle steering, etc.) and alerts them if there is a risk of falling asleep.

It takes into account indicators such as:

- steering wheel movements;
- driver actions on other systems (indicators, brake pedal, etc.).



This function is an additional driving aid in case of risk of fatigue. The function does not operate on the vehicle. The function cannot, under any circumstances, replace the driver's responsibility during driving.

The driver must always adapt their driving according to their alertness, regardless of the system's indications.

Operation



The function is set to notify the driver if:

- a few minutes have elapsed since the vehicle last stopped;
- the vehicle speed is greater than approximately 43 mph (70 km/h).

If there is a risk of fatigue or impaired attention, the "Vigilance alert Have a break" **1** message is displayed on the instrument panel, accompanied by a beep.

Press switch **2 OK** to delete the warning.

After deleting the message, the system continues vigilance monitoring and issues a new warning if necessary.



The driver vigilance warning constantly monitors the driver's attention and can provide several warnings per journey. The system resets every time the engine is started.

Activation/deactivation



For safety reasons, carry out any adjustments while the vehicle is stationary.

ADDITIONAL DRIVING AID FUNCTIONS

i Depending on the vehicle, depending on the length of time following the last time the engine was stopped, the alerts are reactivated:

- when the vehicle is unlocked;
- or
- when a door is opened;
- or
- when the engine is started.

i When the alerts are deactivated, the system continues to assess the driver's state of fatigue.

i Depending on the vehicle, alerts are automatically deactivated when the "Lane Centring" function is activated. To re-activate the warnings, the "Lane Centring" function must be deactivated. For more information → 209.

i Depending on the vehicle, it may not be possible to deactivate alerts.

Activating and deactivating alerts using the "My Safety" button 3



The alerts can be deactivated or activated using "Custom" mode in the "My Safety" function → 171.

If the alerts have previously been deactivated using Custom mode:

- **to deactivate the alerts**, press the button **3** twice. The indicator light on the button **3** goes out;

- **To reactivate the alerts**, press the button **3** once. The indicator light on the button **3** lights up.

Activating and deactivating the alerts from the multimedia screen 4



To activate or deactivate the alerts, please refer to the multimedia instructions.

Select "ON" or "OFF".

Limiting the operation of alerts

Some conditions can disrupt or damage the system operation, for example:

- certain driving styles (incorrect driving etc.);

ADDITIONAL DRIVING AID FUNCTIONS

- driving on a road in poor condition;
- strong side wind;
- The clock is wrongly configured (depending on vehicle);
- winding roads;
- trailer traction.

3

Operating faults

If the system detects a fault, the "Check Fatigue Warning System" mes-

sage and the  warning light are displayed on the instrument panel.

Have the system checked by an authorised dealer.

Detection of road signs



The system displays speed limits on the instrument panel according to road signs detected on the side of the road.

It mainly uses information taken from the camera **1** attached to the windscreen behind the rear view mirror.

Depending on the country, the system also uses information from a map subscription to interpret certain signs (town entrance, etc.).

The sign displayed on the instrument panel changes when a road sign is detected by the system.

Once the speed limiter or the cruise control is activated, you can adapt the limited speed setpoint to the speed limit displayed on the instrument panel by the system (➔ **226** and ➔ **230**).

If the detected speed limit is exceeded, the road sign displayed on the instrument panel is modified to inform the driver.

Location of the camera **1**

Make sure the windscreen is not obscured (by dirt, mud, snow, condensation etc.).

Special features

For vehicles with a map subscription:

- if the vehicle is being driven in a country where the speed units differ from those of the vehicle, the system displays the speed limit sign in the unit of the country, alongside the speed limit converted to the unit used by the vehicle's instrument panel;
- for countries where the speed limit is reduced during rainy weather on some types of roads, the system may alter the detected speed limit after a few seconds of the windscreen wipers being activated.

For vehicles without a map subscription: when driving in a country where speed units differ from those on your vehicle, you can manually select the speed unit shown on the instrument panel (e.g. change the unit from miles to kilometres) in order to display accurate information ➔ **107**.

Note: the system does not take into account exceptional speed limit measures, such as on peak pollution days.

ADDITIONAL DRIVING AID FUNCTIONS

Operation

Warning lights



The function displays the following warning lights:

2. Speed limit signs and additional speed limit signs (speed on exit ramp with arrow, speed with a caravan, speed limit with length of application, etc.)

3. Additional road signs (start of no overtaking zone).

If the detected speed limit is exceeded, the circle around the road sign flashes (warning light **2**) accompanied, depending on the vehicle, by a beep emitted for a few seconds to warn you.

It remains illuminated on the instrument panel as long as the vehicle is exceeding the detected speed limit.

Special features



Map subscription

Road sign detection is associated with a map subscription.

To manage the subscription, please refer to the multimedia instructions.

If there is no subscription, the system will be limited to taking into account the speed limit signs when they are detected by the camera.

The system will no longer take into account information related to the maps. The speed limit availability may be affected.

Activation/deactivation



For safety reasons, carry out any adjustments while the vehicle is stationary.

Depending on the vehicle, warnings can be deactivated or activated from the "Custom" mode of the "My Safety" function → 171.



Depending on the vehicle, depending on the length of time following the last time the engine was stopped, the sound alert is reactivated:

- when the vehicle is unlocked;
- or
- when a door is opened;
- or
- when the engine is restarted.

Activating, deactivating the over-speed sound alert using the "My Safety" button 4

ADDITIONAL DRIVING AID FUNCTIONS

3



The sound alert can be deactivated or activated using "Custom" mode in the "My Safety" function → 171.

If the sound alert has previously been deactivated using "Custom" mode:

- **to deactivate the sound alert**, press the button **4** twice. The indicator light on the button **4** goes out;
- **to reactivate the sound alert**, press the button **4** once. The indicator light on the button **4** lights up.

Activating, deactivating the over-speed sound alert from the multimedia screen 5



To activate or deactivate the sound alert, please refer to the multimedia instructions.

Select "ON" or "OFF".

Variation of the limited speed or cruising speed



To adapt the speed limiter, cruise control or adaptive cruise control setpoint to the detected speed limit, press the **6** switch.

Temporary unavailability

If the system is unavailable for reasons related to the camera or map data, the



symbol is displayed on the instrument panel. If there is still a problem, contact an approved dealer.

The system cannot detect the speed limit if:

- the windscreen is not clean;

ADDITIONAL DRIVING AID FUNCTIONS

- the camera is blinded by the sun;
- there is insufficient visibility (fog, etc.);
- the signs are not legible (snow, etc.) or are hidden (by another vehicle or by trees);
- the information taken from the map is not up to date.

Note: when the front camera is obscured, the "Front camera no visibility" message is displayed on the instrument panel. Clean the windscreen area in front of the camera.

Operating faults

The system cannot detect the speed limit if:

- the windscreen is not clean;
- the camera is blinded by the sun;
- there is insufficient visibility (night, fog etc.);
- the signs are not legible (snow, etc.) or are hidden (by another vehicle or by trees);
- map information is not up to date.

When the system detects an operating

fault, the  is displayed on the instrument panel.

ADDITIONAL DRIVING AID FUNCTIONS

Warnings



This function is an additional driving aid. This function is not under any circumstances intended to replace the due care and attention of the driver, who should at all times be in control of the vehicle.

The driver must always adapt their speed to the highway code and traffic conditions, regardless of system indications.

The system may not detect all speed limit signs or may interpret them incorrectly.

The driver must not ignore road signs undetected by the system and should give priority to complying with the actual road signs and the highway code.

In the event of poor visibility (fog, snow, frost, etc.), it is possible that the system may not indicate the correct speed to the driver

ADDITIONAL DRIVING AID FUNCTIONS

Active driver assist

The "Active driver assist" system is a driving aid for use outside urban areas, on wide roads with visible lines.

This system consists of the "**Adaptive cruise control**" **Stop and Go**" function → 234 and the "**Lane Centring**" function.

This system enables the driver to:

- maintain vehicle speed based on a previously stored speed;
- adjust the distance between their vehicle and the vehicle in front;
- direct the trajectory of the vehicle in the lane;
- adapt the vehicle speed to the speed shown on the road signs, automatically or after confirmation by the driver (depending on the vehicle).

The "Stop and Go adaptive cruise control" function.

Depending on the country and subscription, based on information from a radar, camera or map data sent via a GSM connection, the Stop and Go adaptive cruise control makes it possible to maintain a selected speed, known as the cruising speed, while keeping a safe distance from the vehicle in front in the same lane.

The cruising speed can adjust automatically to a speed limit change (depending on the country and subscription).

If the vehicle in front stops, the Stop and Go adaptive cruise control may brake your vehicle to a complete stop before setting off again.



Important: you should keep your feet near the pedals and your hands on the steering wheel at all times to prepare for any event.

The system controls acceleration and deceleration of your vehicle using the engine and braking system.

The Stop and Go adaptive cruise control function can be activated from 0 to 112 mph (180 km/h), depending on the vehicle and according to road conditions (traffic, weather, etc.).

It is represented by the  → 234 symbol.

Note:

- the driver must observe the maximum speed limit and safe distances according to the legislation in the country where they are driving;

- the adaptive cruise control can brake the vehicle up to a third of the braking capacity. Depending on the situation, the driver may need to brake harder.



The Stop and Go adaptive cruise control does not trigger an emergency stop and its braking capability is limited.

The "Lane Centring" function

Using information from a camera, the "Lane Centring" function manipulates the steering system to direct the vehicle in the lane.

If the conditions allow it, the function is available between:

- 0 mph and a speed between 99 mph (160 km/h) and 112 mph (180 km/h) (depending on the version) with a vehicle in front;

or

- 37 mph (60 km/h) and a speed between 99 mph (160 km/h) and 112 mph (180 km/h) (depending on the version) without a vehicle in front.

The "Lane Centring" function is a comfort feature.

ADDITIONAL DRIVING AID FUNCTIONS

It is represented by the  warning light.

Note: in the event of a sharp bend, the function's lateral retention capacities are limited and require the driver to take immediate action on the steering wheel.

Additional information

Depending on the vehicle, the "Active driver assist" function can be used with other driving aid functions.

Please note that:

- When the "Lane Centring" function is in adjustment mode, this will suspend the "Lane departure prevention" function if it has already been activated. When the "Lane Centring" function is not controlling the steering system, the "Lane departure prevention" function may be reactivated if conditions allow.

ADDITIONAL DRIVING AID FUNCTIONS

Location of components

3

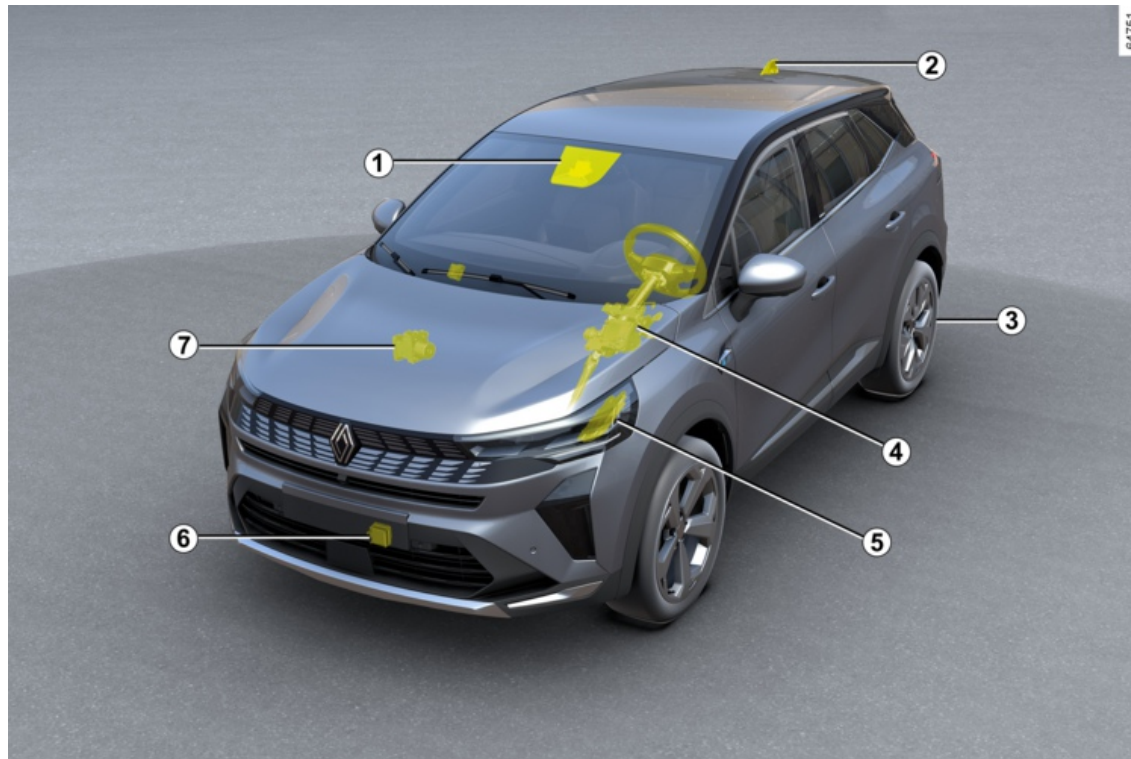

ADDITIONAL DRIVING AID FUNCTIONS

1 Camera

Detects markings on the ground and the position of vehicles on the various traffic lanes.

It receives information from the radar **6** and merges it with its own information to determine the trajectory and speed of the vehicle (acceleration/braking). Amongst other things, it controls the system activation/deactivation parameters (door opening status, etc.).

Depending on the vehicle, it processes information to detect the presence of the driver's hands on the steering wheel.

Make sure the windscreen is not obscured (by dirt, mud, snow, etc.).

2 Aerial and maps

(depending on the country and subscription)

Road maps and certain driving conditions (roundabouts and cornering) are downloaded according to the journey taken by the vehicle. The system can anticipate deceleration following a change of the speed limit indicated on road signs, depending on the parameters selected by the driver.

The system can also adjust the vehicle's speed when approaching a bend or roundabout.

3 Electronic parking brake

Keeps the vehicle stationary under certain conditions.

4 Power-assisted steering

It operates the front wheels to guide the vehicle trajectory according to the information transmitted by the camera **1**. It also enables detection of the driver's hands on the steering wheel.

5 Engine computer

It controls and directs the engine to carry out the required acceleration.

6 Radar

Calculates the distance between your vehicle and the vehicle in front. The system's maximum range is approximately 150 metres. This may vary according to the road conditions (ground relief, weather conditions, etc.).

Ensure that the radar area is not obstructed (dirt, mud, snow, a badly fitted front number plate), impacted, modified (including painting) or hidden by any accessory fitted on the front of the vehicle (on the grille or logo etc.).

7 Active vehicle control

This system supplies information on vehicle dynamics to the camera **1** (speed, lateral acceleration, etc.) and acts on the braking system to control deceleration and to keep the vehicle stationary.



The radar and camera zones must be kept clean and free of any tampering in order to ensure the proper operation of the system.

ADDITIONAL DRIVING AID FUNCTIONS

Controls

3



ADDITIONAL DRIVING AID FUNCTIONS

8 Steering wheel

The driver must always keep their hands on the steering wheel. If too much force is applied when turning the steering wheel, the "Lane Centring" function is put on standby so the driver can regain control of the vehicle.

Under certain conditions (sharp bends, etc.) a vibration may be triggered on the steering wheel to warn the driver that they must regain control of the vehicle.

If the driver does not handle the steering wheel (no hands are detected) the "Lane Centring" function is deactivated after several alerts.

9. Switch for selecting/deselecting the driving aids, depending on the vehicle:

- Active driver assist;
- Adaptive Cruise Control;
- speed limiter;
- OFF.

10. Puts the function on standby and stores the limited speed (0).

11. Safe distance settings

12. Recall the stored cruising speed (RES).

13. Switch to activate or decrease the cruising speed or to store the current speed (SET/-).

14. Switch to activate or increase the cruising speed or recall the stored cruising speed (SET/+).

15. Pop-up button (depending on the vehicle): adapts the speed setpoint to

detected speed limits  → 204

When the "OFF" mode is selected before the ignition is switched off, the "Speed limiter" function will be activated by default the next time the engine is started.

Displays on the instrument panel

16. "Stop and Go adaptive cruise control" function warning light .

17. Stored cruising speed.

18. Vehicle in front.

19. Stored safe distance

20. Left-hand and right-hand line indicators

21. "Lane Centring" function warning light .

ADDITIONAL DRIVING AID FUNCTIONS

Activation/deactivation controls for the "Active driver assist" function

Activating the function



To activate the function, press the switch **9** as many times as necessary to activate it.

The warning light **21**  is displayed in grey on the instrument panel. Then press switch **13** (SET/-) or switch **14** (SET/+).

The "Active driver assist", consisting of the Adaptive cruise control Stop and Go and the "Lane Centring" function, is then activated.

The green warning light **21**  and the left-hand and right-hand line indicators **20** are displayed on the instrument panel to confirm that the function

is in operation and directing your vehicle towards the centre of the lane.

You can interrupt the "Lane Centring" function at any time by forcefully turning the steering wheel. As soon as you stop turning the steering wheel, the "Lane Centring" function is reactivated.

Note: you must keep your hands on the steering wheel when using the "Lane Centring" function. Under no circumstances should you take your hands off the steering wheel.

Deactivating the function

Press the switch **9**. Deactivation of the function is confirmed by the disappear-

ance of the warning light **21**  and the right-hand and left-hand line indicators **20** from the instrument panel.

ADDITIONAL DRIVING AID FUNCTIONS



To exit the driving assistance, press switch **9** as many times as necessary until you reach OFF. The "Driving Assistance deactivated" message appears on the instrument panel. In this case, the next time the engine is started, the "Speed limiter" function will be activated and waiting for a speed limit to be stored.

Adjusting the position in the lane

(depending on the vehicle)



To activate the position in the lane, the "Lane Centring" function must be in

adjustment mode, the green **21**  warning light must be displayed on the instrument panel and the vehicle speed must be below 31 mph (50 km/h).

In these conditions, you can adjust your position in the lane by turning the steering wheel slightly to the right or left, so that the vehicle shifts to the selected side without the "Lane Centring" function being deactivated. As soon as your offset is at least about 15 cm from the middle of the lane, without the vehicle approaching less than about 30 cm from the edge of the lane, you have about 10 seconds to adjust the offset precisely. The vehicle then remains in the offset position when you stop exerting effort to turn the steering wheel. The lines **20** indicate the offset applied. To return to the centre of the lane, turn the steering wheel slightly in the opposite direction, then stop trying once the vehicle has reached the centre.

According to certain conditions (e.g. bend, speed), the vehicle may be re-centred automatically.

"Lane Centring" function on stand-by

The "Lane Centring" function is put on standby automatically in the following cases:

- the system no longer detects the lines or only one line is detected in your lane;
- the lane is too narrow or too wide;
- the system does not detect any hands on the steering wheel;
- in some driving conditions (roundabout, intersection, the bend is too sharp, etc.);
- the vehicle speed is greater than approximately 99 mph or 112 mph (160 km/h or 180 km/h), depending on the vehicle;
- the vehicle speed is below approximately 30 mph (48 km/h), without a vehicle in front;
- the vehicle crosses a line;
- the system is temporarily disrupted (for example: camera obscured by dirt, mud, snow, condensation, etc.).

Certain actions carried out by the driver also suspend the "Lane Centring" function:

- activating the indicators;
- too much force is used when handling the steering wheel.

The function is confirmed to be on standby by the appearance of the grey

ADDITIONAL DRIVING AID FUNCTIONS

warning light **21**  and the left-hand and right-hand line indicators **20** on the instrument panel.



Important: you should keep your feet near the pedals and your hands on the steering wheel at all times to prepare for any event.

Once the conditions are met, the function again directs the vehicle to the centre of the lane. The warning light

21  and the left-hand and right-hand line indicators **20** are displayed in green on the instrument panel.



You can affect **the vehicle trajectory** at any point by turning the steering wheel.

"Keep hands on steering wheel" warning



When the "Lane Centring" function no longer detects your hands on the steering wheel, several warning levels will be triggered:

- **after approximately 15 seconds**, the "Keep hands on steering wheel" message appears in yellow on the instrument panel **22**;
- **after approximately 30 seconds**, the "Keep hands on steering wheel" message appears on the instrument

panel **22** along with the  warning light in red, accompanied by a beep whose volume gradually increases;

- **after approximately 35 seconds**, if the driver does not put their hands on the steering wheel after the warning is displayed, an audible warning sounds continuously. The brakes are then briefly applied repeatedly to inform the driver that they must retake control of the vehicle by putting their hands on the steering wheel. If the driver does not respond, the "Active driver assist" function activates the hazard warning lights and slows down the vehicle until it comes to a complete stop.



The driver can interrupt this manoeuvre at any time by placing their hands on the steering wheel, braking or deactivating the "Active driver assist" function.

- After the vehicle has stopped, the electronic parking brake will automatically be applied, the hazard warning

lights will stay on, the  warning light will switch off and the "Lane centering deactivated" message will appear on the instrument panel to inform you.

ADDITIONAL DRIVING AID FUNCTIONS



In the first two alert levels, when the system again detects the presence of the driver's hands on the steering wheel, the system stops the alerts. The function continues to direct the vehicle to the centre of the lane.

Note: in some situations, the "Lane Centring" function may no longer detect your hands on the steering wheel and may emit an alert:

- the driver is holding the steering wheel very lightly;
- the driver is wearing gloves;
- ...

In the case of a sharp bend



In the case of a sharp bend, and depending on the vehicle speed, the function's side retaining capacities will be limited and require the driver to carry out immediate action on the steering wheel so that the function can continue to maintain the vehicle in the centre of the lane.

If the driver does not intervene, the function triggers the vibration of the steering wheel to signal that the vehicle is about to breach a line and that the driver needs to carry out immediate action.

The warning light **21**  and the left-hand or right-hand line indicator **20**

concerned appear in red on the instrument panel.

If the vehicle crosses a line completely and moves out of lane, the "Lane Centring" function is put on standby. The function is confirmed to be on standby by the appearance of

the grey warning light **21**  and the left-hand and right-hand line indicators **20** on the instrument panel.

Operating faults

If an operating fault is detected in relation to the "Lane Centring" function, the "Driving assist unavailable" or "Check Driving assist" message is displayed on the instrument panel and the function is deactivated.

Consult an approved dealer.

ADDITIONAL DRIVING AID FUNCTIONS

Warning



The "Active driver assist" is an additional driving aid. It can under no circumstances replace the driver's responsibility to respect speed limits and safe distances and to be vigilant.

The driver must always be in control of the vehicle.

The driver must always adapt their trajectory and speed according to the surroundings and driving conditions, regardless of system indications.

Except for lines delimiting lanes and the speed limit signs within the limits of the system's detection capacity, the road sign information (other traffic signs, traffic lights, pedestrian crossings, etc.) are not recognised by the system. These do not trigger any alert or reaction by the system.

The "Active driver assist" uses the "Stop and Go adaptive cruise control" and "Lane centring" functions. The system should under no circumstances be taken to be an obstacle detector or an anti-collision system.

Use the "Active driver assist" only outside built-up areas, on wide roads with visible lines.

It must not be used in heavy traffic, on winding or slippery roads (black ice, aquaplaning, gravel) or during bad weather (fog, rain, side winds etc.).

There is a risk of accidents.

System servicing/repairs

– In the event of an impact, the radar and/or camera alignment may be changed and its operation may consequently be affected. Deactivate the system and consult an authorised dealer.

– Any work in the proximity of the radar and/or camera (replacements, repairs, windscreen modifications, paintwork etc.) must be carried out by a qualified professional.

Only an authorised dealer is qualified to service the system.

ADDITIONAL DRIVING AID FUNCTIONS



Deactivating the system

You must deactivate the system if:

- the vehicle is travelling on a winding road;
- the vehicle is being towed (breakdowns);
- the vehicle is towing a trailer or a caravan;
- the vehicle is being driven in a tunnel or close to a metallic structure;
- the vehicle arrives at a toll point, a roadwork area or on a narrow lane;
- the vehicle is being driven up or down a very steep slope;
- the visibility is poor (glaring sun, fog, etc.);
- the weather conditions are poor (rain, snow, side winds, etc.);
- the vehicle is being driven on a slippery road surface (rain, snow, gravel, etc.);
- the camera area has been damaged (e.g. interior or exterior windscreen area); the windscreen is cracked or distorted;
- the radar area has been damaged (impacts, etc.);
- the surface of the steering wheel is damaged or damp.

In the event of the system behaving abnormally, deactivate it and contact an authorised dealer.

ADDITIONAL DRIVING AID FUNCTIONS



Some conditions can disrupt or damage the system operation, for example:

- obstruction of the windscreen or the radar area (by dirt, ice, snow, condensation etc.) Frequently check the cleanliness and condition of the windscreen, front wiper blades and front bumper;
- a complex environment (tunnel, etc.);
- poor weather conditions (snow, heavy rain, hail, black ice, etc.);
- poor visibility (night, fog, etc.);
- poor contrast between the vehicle preceding it and the surrounding area (e.g. white vehicle in a snowy area, etc.);
- being dazzled (glaring sun, lights of vehicles travelling in the opposite direction; etc.);
- narrow, winding or undulating road (tight bends, etc.);
- the tar lines detected as a line by the system;
- narrowing/widening lanes;
- road markings which are worn, lacking in contrast or very widely spaced from one another (lines partially erased; etc.);
- multiple markings on the road (roadworks area, slip roads connecting to adjacent motorways, hard shoulder, etc.);
- road signs that do not include an arrow, located on a motorway exit;
- an area with low connectivity that makes it impossible to geolocate the vehicle, or maps that are not up-to-date;
- a vehicle with a significant difference in speed;
- use of mats not adapted to the vehicle. On the driver's side, only use mats suitable for the vehicle, attached with the pre-fitted components, and check the fitting regularly. Do not lay one mat on top of another. **There is a risk of wedging the pedals.**

In these cases:

- **Risk of unwanted braking or acceleration.**
- **Risk of unwanted, incorrect correction or no correction of trajectory.**

Many unforeseen situations may affect the system operation. Certain objects or vehicles that can appear in the camera or radar detection zone may be interpreted by the system incorrectly, possibly leading to inappropriate acceleration or braking. **You should always be attentive to sudden events that might occur while you are driving. Always maintain your vehicle under control by keeping your feet near the pedals and your hands on the steering wheel, so that you are ready to act in any event.**

ADDITIONAL DRIVING AID FUNCTIONS

Active emergency braking in reverse gear

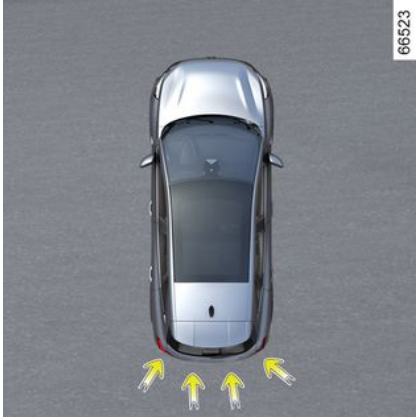

In addition to the "Park Assist" function → 252 and using information from the four central sensors located at the rear of the vehicle, the system detects fixed obstacles located behind your vehicle. If there is a significant risk of collision, the system automatically causes the vehicle to brake.

Note: make sure that the four central sensors located at the rear of the vehicle are not obscured (by dirt, mud, snow, etc.).

Operation

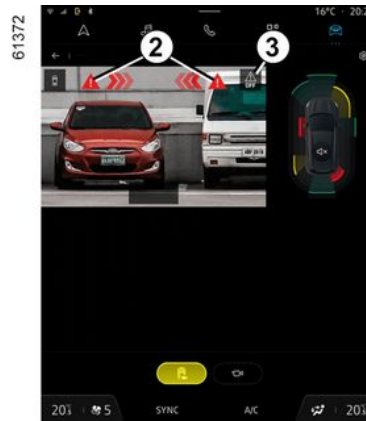

Fixed rear obstacle detection

When in reverse gear and moving at between approximately 2 mph and 6 mph (3 km/h and 10 km/h), if there is a risk of collision with a fixed obstacle, the system **automatically brakes the**

vehicle. A visual warning  **2** is displayed on the multimedia screen **1**, accompanied by a beep.

Once the vehicle has stopped, the vehicle must be held stationary by the driver keeping their foot on the brake pedal.



This function is an additional driving aid. This function is not under any circumstances intended to replace the due care and attention of the driver, who should at all times be in control of the vehicle.

ADDITIONAL DRIVING AID FUNCTIONS



An impact to the underside of the vehicle while manoeuvring (e.g. striking a post, raised kerb or other street furniture) may result in damage to the vehicle (e.g. deformation of an axle).

To avoid any risk of accident, have your vehicle checked by an approved dealer.

Activating or deactivating the system



To activate or deactivate the function, select the "Vehicle" world, then "Park-

ing aids". Select "Active emergency braking in reverse gear".

If the function is deactivated, the warn-

ing light  is displayed on the multimedia screen.

Operating faults

When the system detects an operating fault, active emergency braking in reverse gear is automatically deactivated.

The warning light  is displayed on the multimedia screen accompanied by, depending on the type of malfunction, the following message on the instrument panel:

- "Parking sensors unavailable";
- or
- "Check parking sensors";
- or
- "Driving aids unavailable";
- or
- "Check driving aids".

Depending on the vehicle, the message is accompanied by the display of

the  warning light on the instrument panel.

Clean the ultrasonic sensors. If there is still a problem, contact an approved dealer.

If the vehicle is fitted with a towbar recognised by the system and a trailer has been connected, active emergency braking in reverse gear is automatically deactivated and the "Trailer: parking sensors off" message is displayed on the instrument panel, accompanied by the warning light 

on the multimedia screen.

ADDITIONAL DRIVING AID FUNCTIONS

Warnings



Active emergency braking in reverse gear

This function is an additional driving aid. This function cannot, under any circumstances, replace the vigilance and responsibility of the driver.

Some climatic and environmental conditions can disrupt or damage the system. As a consequence, the driver should always be ready for sudden incidents while driving: always ensure that there are no small, narrow moving obstacles (such as a child, animal, pushchair, bicycle, stone, post, etc.) in the blind spot when manoeuvring.

The triggering of this function may be delayed or prevented when the system detects clear signs of control of the vehicle by the driver (action on the steering wheel, pedals etc.).

System servicing/repairs

- In the event of an impact, the rear sensors and their performances may be affected. Deactivate the function and consult an authorised dealer.
- Any work in the area where the sensors are located (repairs, replacements, bumper modifications etc.) must be carried out by a qualified professional.

Only an authorised dealer is qualified to service the system.

Deactivating the function

You must deactivate the function if the vehicle is being towed (breakdown recovery) or if the vehicle is fitted with a towbar that is not recognised by the system.

In the event of the system behaving abnormally, deactivate it and consult an authorised dealer.

SPEED LIMITER

The speed limiter function controls the engine and braking system to help you not to exceed a driving speed that you have chosen, known as the **limit speed**.

 Depending on the vehicle, you can link the speed limiter function to the "Road sign detection" function → **204**.

Controls



1. Switch for selecting/deselecting the driving aids, depending on the vehicle:

– Active driver assist;

- Adaptive Cruise Control;
- cruise control;
- speed limiter;
- OFF.

2. Puts the function on standby and stores the limited speed (0).

3. Recalling the stored limit speed (RES).

4. Switch to activate and decrease the limit speed or to store the current speed (SET/-).

5. Switch to activate and increase the limit speed or to recall the stored limit speed (SES/+).

6. Pop-up button (depending on the vehicle): adapts the speed setpoint to

detected speed limits  → **204**

When the "OFF" mode is selected before the ignition is switched off, the "Speed limiter" function will be activated by default the next time the engine is started.

Driving

When a limit speed has been set but not yet reached, driving is similar to driving a vehicle without the speed limiter function.

Once you have reached the stored speed, no effort on the accelerator pedal will allow you to exceed the pro-

grammed speed except in an emergency (refer to information on "Exceeding the limit speed").

Switching on



SPEED LIMITER



Press switch **1** as many times as necessary to select the speed limiter **A**. The **7** warning light appears in grey. The "Speed limiter ready: SET to activate" message appears on the instrument panel accompanied by dashes to indicate that the speed limiter function is activated and waiting for a limit speed to be stored.

Note: depending on the vehicle, when the vehicle is started, the speed limiter is automatically selected if the function **A** or OFF was selected the last time the vehicle was stopped.

To store the current speed, press the **4** switch (SET/-) or the **5** switch (SET/+): the limit speed replaces the dashes

and, depending on the vehicle, the **7** warning light appears in white.

The minimum stored speed is 19 mph (30 km/h).

Varying the limit speed



The limit speed may be changed by pressing repeatedly or holding down:

- switch **5** (SET/+) to increase the speed;
- switch **4** (SET/-) to reduce speed.

Automatic speed limiter with speed limit sign recognition

(depending on subscription: without a subscription this function cannot be ac-

tivated. To manage your subscription, see the multimedia instructions.)

Using the camera, the "Road sign detection" function → **204** and the map associated with the subscription, the system automatically limits the vehicle speed when a speed limit road sign is identified and passed.

Activation/deactivation

From the multimedia screen, in the "Vehicle" world, select "Driving aids". Then, from the "Speed adaptation" menu view the "Adaptive cruise control" field and select "To speed limits".

Note: you can also activate/deactivate by pressing and holding the contextual button **6**.

Exceeding the limit speed

It is possible to exceed the limit speed at any moment. To do this, press the accelerator pedal **firmly down** beyond the point of resistance.

While the speed is being exceeded, the speed limiter flashes red on the instrument panel. Then, release the accelerator pedal: the speed limiter function will return as soon as you reach a speed lower than the memorised speed.

SPEED LIMITER



You must keep your feet near the pedals to be ready to react in an emergency.



If the speed limiter is not available (after several attempts to activate), contact an approved

dealer.

Limited speed cannot be maintained

When driving down a steep slope, the system may not maintain the limit speed: in this case the limited speed flashes in red on the instrument panel and a beep sounds at regular intervals to inform you.

Putting the function on standby



The speed limiter function is suspended when you press switch **2** (0). The limit speed is stored and displayed in grey on the instrument panel.

Recalling the limit speed

If a speed has been stored, it can be recalled by pressing the switch **3** (RES).



When the speed limiter is set to standby, pressing switch **4** or **5** reactivates the function without taking into account the stored speed: it is the speed at which the vehicle is moving that is taken into account.

Switching off the function



The speed limiter function is interrupted when you press the switch **1** to deselect the speed limiter. In this case, the speed is no longer stored

SPEED LIMITER

The **7** warning light disappears from the instrument panel to confirm that the function has stopped.



To exit the driving assistance, press switch **1** as many times as necessary until OFF. The message "Driving Assistance deactivated" appears on the instrument panel. In this case, the next time the engine is started, the "Speed limiter" function will be activated and waiting for a speed limit to be stored.

CRUISE CONTROL

The cruise control function controls the engine and braking system to help you to maintain a driving speed that you have chosen, known as the **cruising speed**.

This cruising speed can be set at any speed above 19 mph (30 km/h).

 Depending on the vehicle, you can link the cruise control function to the "Road sign detection" function → 204.

Controls



1. Switch for selecting/deselecting the driving aids, depending on the vehicle:

- Active driver assist;
- Adaptive Cruise Control;
- cruise control;
- speed limiter;
- OFF.

2. Puts the function on standby and stores the limited speed (0).

3. Recall the stored cruising speed (RES).

4. Activates and decreases the cruising speed or stores the current speed (SET/-).

5. Switch to activate and increase cruising speed or to recall the memorised cruising speed (SET/+).

6. Pop-up button (depending on the vehicle): adapts the speed setpoint to

detected speed limits  → 204

When the "OFF" mode is selected before the ignition is switched off, the "Speed limiter" function will be activated by default the next time the engine is started.



This function is an additional driving aid.

It can under no circumstances replace the driver's responsibility to respect speed limits or to be vigilant. The driver must always be in control of the vehicle.

Cruise control must not be used in heavy traffic, on winding or slippery roads (black ice, aquaplaning, gravel) and during bad weather (fog, rain, side winds etc.).

There is a risk of accidents.

CRUISE CONTROL

Switching on



Press switch **1** as many times as necessary to select the cruise control **7**. The **8** warning light appears in grey. The "Cruise control ready: SET to activate" message appears on the instrument panel accompanied by dashes to indicate that the cruise control function is activated and waiting to store a cruising speed.

Activating cruise control

While the vehicle is moving a steady speed above approximately 19 mph (30 km/h), press switch **5** (SET/+) or switch **4** (SET/-): the function is activated and the current speed is taken into account. The cruising speed replaces the dashes.

The cruising speed replaces the dashes. Cruise control is confirmed when the memorised speed and warning light appear in green **8**.

If you try to activate the function below 19 mph (30 km/h), the "Speed invalid" message will be displayed and the function will remain deactivated.

Driving

Once a cruising speed is registered and the cruise control function is active, you may lift your foot off the accelerator pedal.



Please note that you must keep your feet close to the pedals in order to react in an emergency.

Adjusting the cruising speed

The cruising speed may be changed by repeatedly pressing the:

- switch **4** (SET/-) to reduce the speed;
- switch **5** (SET/+) to increase the speed.

Note: press and hold one of the switches to modify speed by successive increments.

Exceeding the cruising speed

The cruising speed may be exceeded at any time by depressing the accelerator pedal.

While it is being exceeded, the cruising speed flashes in red on the instrument panel. Then, release the accelerator pedal: after a few seconds, the vehicle will automatically return to its set cruising speed.

Cruising speed cannot be maintained

CRUISE CONTROL

In the case of a steep descent, the system may not maintain the cruising speed: the stored speed flashes in red on the instrument panel and a beep sounds at regular intervals to inform you.



If the cruise control is no longer available (after several attempts to activate it), contact an Approved Dealer.

Putting the function on standby



The function is set to standby if you:

- the switch **2** (0);

- the brake pedal;
- move to the neutral position.

The cruising speed is stored and displayed in grey on the instrument panel.

Returning to the cruising speed

If a speed is stored, it can be recalled, once you are sure that the road conditions are suitable (traffic, road surface, weather conditions, etc.). Press the switch **3** (RES) if the vehicle speed is above 19 mph (30 km/h).



When the speed is stored, cruise control activation is confirmed by the display in green of the cruising speed and, depending on the vehicle, the warning light **8** appears.

Note: if the speed previously stored is much higher than the current speed,

the vehicle will accelerate more rapidly to reach this threshold.

When the cruise control is on standby, press switch **4** or **5** to reactivate the cruise control function without taking into account the stored speed: it is the speed at which the vehicle is moving that is taken into account.

Switching off the function

The cruise control function is interrupted when you press the switch **1** to deselect the cruise control. In this case, the speed is no longer stored.



To exit the driving assistance, press switch **1** as many times as necessary until you reach OFF. The "Driving Assistance deactivated" message appears on the instrument panel. In this case, the next time the engine is started, the "Speed limiter" function will be activated and waiting for a speed limit to be stored.

CRUISE CONTROL



The **8** warning light disappears from the instrument panel to confirm that the function has stopped.



Putting the cruise control on standby or switching it off does not cause a rapid reduction in speed: you must brake by pressing the brake pedal.

ADAPTIVE CRUISE CONTROL

Based on information from a radar or camera, the adaptive cruise control function (or the Stop and Go adaptive cruise control function on vehicles equipped with an automatic gearbox) enables you to maintain the speed selected, known as the cruising speed, while keeping a following distance with the vehicle in front in the same lane.

Depending on the vehicle, when the "Road Sign Detection" function is activated ➔ 204, the system can adapt the speed of your vehicle according to the speed limit signs recognized by the camera.

Depending on the country and subscription, the system will use the camera and the map to adjust the vehicle speed in advance according to the context and road incidents (roundabouts, bends, upcoming road signs or speed limit zones).

If the vehicle in front stops, the Stop and Go adaptive cruise control may brake your vehicle to a complete stop before allowing the vehicle to move on again.

The system controls acceleration and deceleration of your vehicle using the engine and braking system.

The system's maximum range is approximately 130 metres. This may vary

according to the road conditions (ground relief, weather conditions, etc.)

The "Adaptive cruise control" function can be activated from 0 mph (0 km/h), depending on conditions on the road (traffic, weather, etc.).

The function is indicated by the  symbol.

Note:

- the driver must observe the maximum speed limit and safe distances according to the legislation in the country where they are driving;
- the adaptive cruise control can brake the vehicle up to a third of the braking capacity. Depending on the situation, the driver may need to brake harder.

Based on information from a radar or camera, the Stop and Go adaptive cruise control function gives you the option of maintaining a selected speed, known as the cruising speed, while keeping a safe distance from the vehicle in front in the same lane.

Depending on the vehicle, when the "Road Sign Detection" function is activated ➔ 204, the system can adapt the speed of your vehicle according to the speed limit signs recognized by the camera.

Depending on the country and subscription, the system will use the cam-

era and the map to adjust the vehicle speed in advance according to the context and road incidents (roundabouts, bends, upcoming road signs or speed limit zones).

If the vehicle in front stops, the Stop and Go adaptive cruise control may brake your vehicle to a complete stop before allowing the vehicle to move on again.

The system controls acceleration and deceleration of your vehicle using the engine and braking system.

The system's maximum range is approximately 130 metres. This may vary according to the road conditions (ground relief, weather conditions, etc.)

The Stop and Go adaptive cruise control function can be activated from 0 mph (0 km/h).

The function is indicated by the  symbol.

Note:

- the driver must observe the maximum speed limit and safe distances according to the legislation in the country where they are driving;
- the adaptive cruise control can brake the vehicle up to a third of the braking capacity. Depending on the situation, the driver may need to brake harder.

ADAPTIVE CRUISE CONTROL



The Stop and Go adaptive cruise control does not trigger an emergency stop and its braking capability is limited.



This function is an additional driving aid.

It can under no circumstances replace the driver's responsibility to respect speed limits and safe distances or to be vigilant.

The driver must always be in control of the vehicle.

The driver must always adapt their speed according to the surroundings and traffic conditions.

Use the adaptive cruise control outside built-up areas, on wide roads with visible lines.

The cruise control may have limited operation on very winding or slippery roads (black ice, aquaplaning, gravel) or during bad weather (fog, rain, side winds, etc.)

There is a risk of accidents.

Location of the camera and radar



Camera 1

Make sure the windscreen is not obscured (by dirt, mud, snow, condensation etc.).

Radar 2

Ensure that the radar area is not obstructed (dirt, mud, snow, a badly fitted/attached front number plate), impacted, modified (including paintwork) or hidden by any accessory fitted on the front of the vehicle (on the grille or logo etc.).



The radar and camera zones must be kept clean and free of any tampering in order to ensure the proper operation of the system.

Controls



3. Switch for selecting/deselecting the driving aids, depending on the vehicle:

- Active driver assist;
- Adaptive Cruise Control;
- cruise control;
- speed limiter;
- OFF.

ADAPTIVE CRUISE CONTROL

4. Safe distance settings
5. Recall the stored cruising speed (RES).
6. Activates, stores or reduces the cruising speed or stores the current speed (SET/-).
7. Switch to activate and increase cruising speed or to recall the memorised cruising speed (SET/+).
8. Puts the function on standby and stores the limited speed (0).
9. Pop-up button (depending on the vehicle): adapts the speed setpoint to detected speed limits  → 204



Depending on the vehicle, you can link the adaptive cruise control function to the "Road sign detection" function → 204 by pressing the switch 7.

When the "OFF" mode is selected before the ignition is switched off, the "Speed limiter" function will be activated by default the next time the engine is started.

Displays

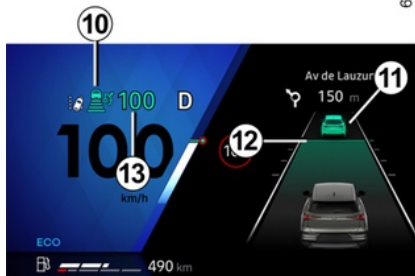

10. Adaptive cruise control warning light.
11. Vehicle in front.
12. Stored safe distance
13. Stored cruising speed.



Important: you should keep your feet near the pedals at all times to prepare for any event.

Switching on

Press switch **3** as many times as necessary to select adaptive cruise control.



The warning light appears in grey and the "Adaptive cruise control ready: SET to activate" message appears on the instrument panel accompanied by dashes to indicate that the function is activated and waiting to store a cruising speed.

This function cannot be activated when:

- the parking brake is applied;
- the driver's seat belt is not fastened;
- one or more doors are incorrectly closed;
- the "Hands-free parking" function is already activated.

The "Adaptive Cruise Ctl unavailable" message is displayed on the instrument panel.

Activating cruise control

When the vehicle is stationary or moving at a steady speed, press switch **7** (SET/+) or switch **6** (SET/-) to activate the function and store the current speed.

The minimum cruising speed is 19 mph (30 km/h).

ADAPTIVE CRUISE CONTROL

If your vehicle speed is lower than approximately 19 mph (30 km/h), the function uses a default cruising speed of 19 mph (30 km/h). The vehicle will accelerate until it reaches the stored cruising speed.

The cruising speed **13** replaces the

dashes and the  warning light and the cruising speed are displayed in green to confirm that the cruise control function is in operation.

If you try to activate the function when the vehicle is travelling over 112 mph (180 km/h), the "Speed invalid" message will be displayed and the function will remain deactivated.

Once a cruising speed is memorised and the cruise control function is active, you may lift your foot off the accelerator pedal.

Activating cruise control with speed limit sign recognition (display A)

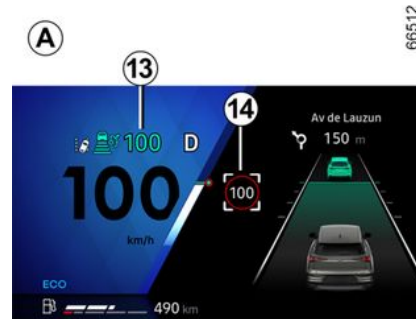
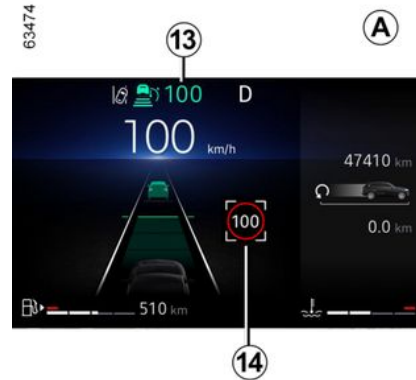

(depending on the vehicle)

If the vehicle is equipped with the "Road Sign Detection" → 204 function, press the contextual button **9** to adapt the vehicle's speed to the **14** speed limits detected by the camera.

When passing the sign, the cruising speed **13** adopts the value of the detected speed **14**.

Activating cruise control with advance speed limit sign recognition (display B)

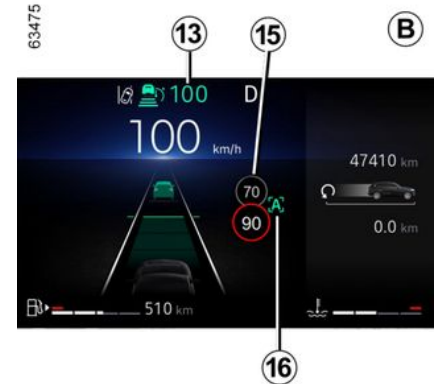

ADAPTIVE CRUISE CONTROL

3

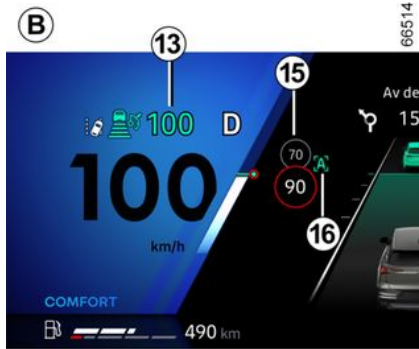

(depending on subscription)

Using the camera, the "Road sign detection" function → 204 and the map associated with the subscription, the system anticipates the automatic adjustment of the vehicle speed until the next sign is identified 15.

Activation/deactivation

From the multimedia screen, in the "Vehicle" World, select "Driving assistance". Then, from the "Comfort" menu, select "Speed limit adaptive cruise control".

The letter "A" 16 is displayed on the instrument panel to confirm the activation of the cruise control with advance speed limit sign recognition.

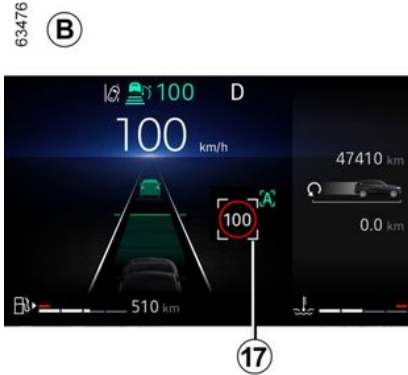

Note: activation/deactivation is also possible by pressing and holding the contextual button 9.

- you can also activate/deactivate the function by pressing and holding the pop-up button 9;
- in some cases (if there is a significant difference between the vehicle speed and limited speed), the system may request that you validate the speed manually by pressing the pop-up button 9: the white square 17 is displayed around the indicated speed to inform you.

i Cruise control with advance speed limit sign recognition is associated with a subscription. If there is no subscription, this function cannot be activated.

To manage the subscription, please refer to the multimedia instructions.

Operation

With the function activated, the following speeds are displayed on the instrument panel:

- cruising speed 13;
- the current speed limit 14 detected by the system on the section of road on which the vehicle is moving;

ADAPTIVE CRUISE CONTROL

– the speed **15** detected by the system on the next road section or speed limit zone.

The detected speed **15** is taken into account by the system. The vehicle speed adjusts gradually, until it becomes the cruising speed **13**, without any action from the driver. The speed indicated on **15** is displayed on **14** when passing the sign or zone identified.

The driver must always stay vigilant regarding the speed applied by the system and remains responsible for the vehicle speed.

When the function is not activated or the subscription is no longer active, the operation is identical to setting the cruising speed with speed limit sign recognition (display **A**).

Activating cruise control with advance recognition of the road layout (display **C**)



(depending on subscription)

Using the camera, the "Road sign detection" → **204** function, and the mapping purchased with the subscription, the system can anticipate and manage the automatic adaptation of the cruising speed **13**, when the vehicle approaches a roundabout or a bend.

If the vehicle is approaching a bend or roundabout, a **18** warning light appears on the instrument panel. The vehicle adjusts its speed to a speed appropriate to the feature detected.

The driver must always stay vigilant regarding the speed applied by the

system and remains responsible for the vehicle speed.

Activation/deactivation

From the multimedia screen, in the "Vehicle" World, select "Driving assistance". Then, from the "Comfort" menu, select "Road layout adaptive cruise control".

When the function is not activated or the subscription is no longer active, operation is the same as setting the cruising speed with speed limit sign recognition (display **A** or, depending on the subscription, setting the cruising speed with advanced speed limit sign recognition (display **B**).

The following symbols show the features taken into account by the system:

-  roundabout;
-  bend.

ADAPTIVE CRUISE CONTROL



Cruise control with advance recognition of the road layout is associated with a subscription.

If there is no subscription, this function cannot be activated.

To manage the subscription, please refer to the multimedia instructions.

Controlling cruising speed

You can resume control of the vehicle speed at any time by:

- putting the function on standby:
 - by pressing the brake pedal;
 - or by pressing the switch **8** (0);
- by pressing the driving aids selection/deselection switch **3**.

When automatically adapting the speed to the signs and/or road layout, it is possible to ignore these events.

Press and hold on:

- the switch **7** (SET/+) to return to the stored cruising speed;
- the switch **6** (SET/-) to store and maintain the current speed.

Safe distance control activation

As soon as cruise control is activated, the default safe distance **12** is displayed in green on the instrument panel. The default following distance corresponds to approximately 2 seconds.

If the system detects a vehicle in your lane, an outline of a vehicle **11** appears above the distance gauge **12** on the instrument panel.

Your vehicle adapts its speed to that of the vehicle in front and applies the brakes if necessary (the brake lights come on) in order to maintain the distance displayed on the instrument panel.

Note: the size of the **11** outline varies according to the distance separating you from the vehicle in front. The larger the outline, the closer the vehicle in front.

Setting the cruising speed



You can vary the speed by pressing repeatedly (for low variation) or pressing and holding (for high variation):

- the "SET/-" switch **6** to reduce the speed;
- the "SET/+" switch **7** to increase the speed.

ADAPTIVE CRUISE CONTROL

Adjusting the following distance



You can vary the safe distance from the vehicle in front at any time by pressing switch **4** repeatedly.

The horizontal distance gauge on the instrument panel indicates the various available safe distances:

- distance gauge **D**: long distance (corresponding to approximately 2.4 seconds);
- distance gauge **E**: intermediate distance 2 (corresponding to approximately two seconds);
- distance gauge **F**: intermediate distance 1 (corresponding to approximately 1.6 seconds);

– distance gauge **G**: short distance (corresponding to approximately 1.2 seconds).

The selected distance gauge appears in green on the instrument panel. The other gauges remain in grey.

Note: the distance must be set according to the traffic level, local regulation and weather conditions.



The safe distance is adjusted by default on the distance gauge **E**.

Exceeding the cruising speed

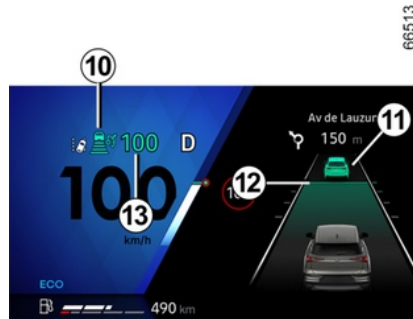

The cruising speed may be exceeded at any time by applying the accelerator pedal.

During overtaking, the cruising speed **13** is displayed in yellow: the "Distance Control" function is no longer ensured.

Then, release the accelerator pedal: the cruise control and safe distance control will automatically resume the speed and distance instructions that you had previously selected.

Overtaking manoeuvre

If you want to overtake the vehicle in front and your speed is over 43 mph (70 km/h) only, activating the direction indicators temporarily reduces the following distance and triggers acceleration to facilitate overtaking.

Stop and start

If the vehicle in front slows down, the system adapts its speed, if necessary to a complete stop (e.g. in heavy traffic). The vehicle stops a few metres from the vehicle in front.

When the vehicle in front sets off again:

- if the stop lasts for less than thirty seconds, the vehicle will start again without any action required from the driver.

ADAPTIVE CRUISE CONTROL

Note: the driver should always be ready for sudden incidents while driving and remains responsible for controlling the vehicle: if the system detects a pedestrian in the area around the vehicle, the automatic restart will be inhibited until the next stop;

– if the stopping time exceeds approximately thirty seconds, for the vehicle to set off again it is necessary to either:

- press the accelerator pedal;
- press the button **5** (RES) once.

The message "Press RES or accelerate to restart Cruise Control" appears on the instrument panel to confirm.

If the stop exceeds around three minutes, the electronic parking brake is automatically applied and the adaptive cruise control is deactivated. The



warning light **10** disappears to confirm that the function is deactivated.

Putting the function on standby

You can set the function to standby when:

- you press switch **8** (0);
- you apply the brake pedal while the vehicle is moving.

The function is deactivated by the system if:

- you set the automatic gearbox to **P** or **N**;
- you engage the reverse gear;
- you unbuckle the driver's seat belt;
- you open one of the opening elements;
- you press the engine start/stop button;
- the slope is too steep;
- the vehicle speed is above 112 mph (180 km/h);
- certain driving aids and correction devices are triggered (active emergency braking, ABS, ESC).

Note: Depending on the vehicle, if the reception of the connected data is not optimal, the system automatically switches on standby the advance speed limit sign recognition and/or advance recognition of the road layout functions.

The two functions are automatically reactivated as soon as reception of the connected data becomes optimal again.

In all circumstances, the standby status is confirmed when the warning lights appear in grey and the "Adaptive cruise control disconnected" message appears on the instrument panel.



Putting the adaptive cruise control on standby or switching it off does not cause a rapid reduction in speed: you must brake by pressing the brake pedal if necessary.

Exit from standby

Based on the stored cruising speed

If a speed is stored, it can be recalled, once you are sure that the road conditions are suitable (traffic, road surface, weather conditions, etc.).

Press switch **5** (RES) or switch **7** (SET/+) within the range of valid speeds.

When the stored speed is recalled, activation of the cruise control is confirmed by the illumination of the cruising speed in green.

Note: if the stored speed is higher than the current speed, the vehicle will accelerate to reach that speed.

Based on the current speed

When the cruise control is set to standby, pressing switch **6** (SET/-) reactivates the cruise control function without taking into account the stored speed: it is the speed at which the ve-

ADAPTIVE CRUISE CONTROL

hicle is moving that is taken into account.

"Take control of the vehicle" warnings

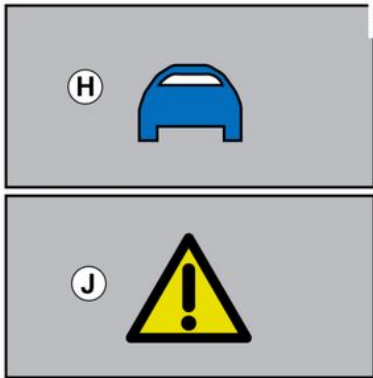

In some situations (e.g. coming up on a much slower vehicle, vehicle in front changing lanes quickly, etc.) the system may not have time to react.

Depending on the situation, the system sounds a beep associated with:

- the orange alert **H** if the situation requires the driver's attention;
- or

– the red alert **J** accompanied by the "Brake" message if the situation requires immediate action by the driver.

In all situations, react accordingly and perform the appropriate manoeuvres.

Switching off the function



The "Adaptive cruise control" function is interrupted when you press switch **3**.

The warning light  disappears from the instrument panel to confirm that the function is no longer active.

 To exit the driving assistance, press switch **3** as many times as necessary until OFF. The message "Driving Assistance deactivated" appears on the instrument panel. In this case, the next time the engine is started, the "Speed limiter" function will be activated and waiting for a speed limit to be stored.

Temporary unavailability

Radar

The radar is able to detect vehicles in front of your vehicle. The system cannot operate correctly if the radar detection area is obscured or if its signal is disrupted.

If the radar detection area is obstructed or the radar signal is disrupted, the "Front radar no visibility" message is displayed on the instrument panel and the adaptive cruise control function is interrupted.

The green warning light **10** disappears to confirm that the function has been automatically deactivated.

ADAPTIVE CRUISE CONTROL

Ensure that the radar area remains clean and is not obstructed by snow, mud, a badly fitted number plate or by any accessory fitted on the front of the vehicle (on the grille), or hidden by any accessory fitted on the front of the vehicle (on the grille or logo, etc.).

Conditions in certain geographical areas may hinder the function, for example:

- arid zones, tunnels, long bridges or lightly used roads without road lines, without signs or trees nearby;
- a military or airport zone.

You must leave such areas in order for the function to work.

In all cases, if the message is not erased after the engine is restarted, please contact an authorised dealer.

Camera

The system cannot operate if the camera is obscured (by dirt, mud, snow, condensation, etc.).

In the event of decreased visibility of the camera, the performance of the adaptive cruise control will be reduced. Remain vigilant.

Operating faults

If an adaptive cruise control function operating fault is detected, the "Check

adaptive cruise control" message appears on the instrument panel and the adaptive cruise control function is suspended.

If an operating fault is detected on one or more components of the system, the adaptive cruise control function is interrupted.

Depending on the type of malfunction, the message is displayed on the instrument panel:

- "Check Front camera" accompanied, depending on the vehicle, by the



warning light;

- "Front radar to check" accompanied, depending on the vehicle, by the



warning light;

- "Check Camera/Radar" accompanied, depending on the vehicle, by the



warning light;

- "Check vehicle" accompanied by the



warning light.

Consult an approved dealer.

Limitations of system operation

Vehicle detection

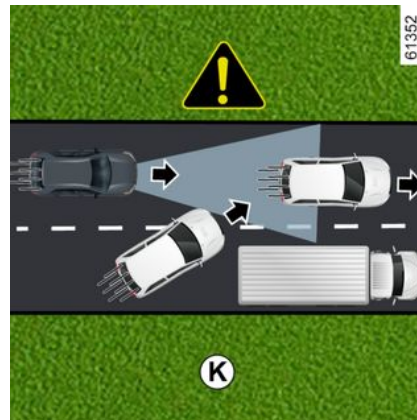

The system detects only vehicles (cars, trucks, motorbikes) that are moving in the same direction as your vehicle.

A vehicle turning into the same lane (e.g. **K**) will be taken into account by the system only once it enters the camera and radar detection areas.

The system may trigger abrupt or delayed braking.

ADAPTIVE CRUISE CONTROL



The system cannot detect:

- vehicles arriving at intersections: slip road (example **L**);
- vehicles driving on the wrong side of the road or reversing towards you.



The adaptive cruise control must be used outside built-up areas, on wide roads with visible lines.

Detection during cornering



When entering a corner or bend, the radar and/or camera may be temporarily unable to detect the vehicle in front (e.g. **M**).

The system may trigger an acceleration.

When exiting a bend, the system's detection of the vehicle in front may be disrupted or delayed.

The system may trigger abrupt or delayed braking.

Detection of vehicles in adjacent lanes

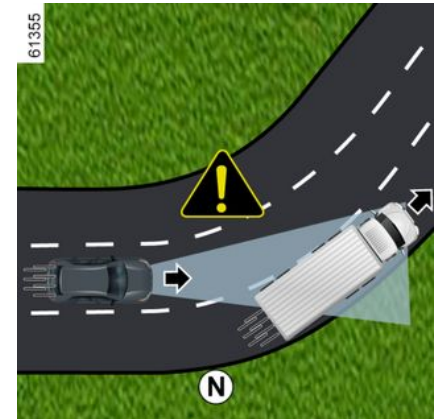

The system may detect vehicles driving on an adjacent lane when:

- you drive into a bend (example **N**);
- you are driving on a road with narrow lanes;
- the speed of the vehicle on the adjacent lane is slower and if one of these vehicles is located too close to the lane of the other.

The system may incorrectly trigger vehicle slowing or braking.

ADAPTIVE CRUISE CONTROL

Vehicles hidden due to variations in ground relief

The system will not detect vehicles hidden due to variations in ground relief or those located outside of the camera and radar detection areas when driving uphill or downhill.

Vehicles outside the camera and radar detection areas.

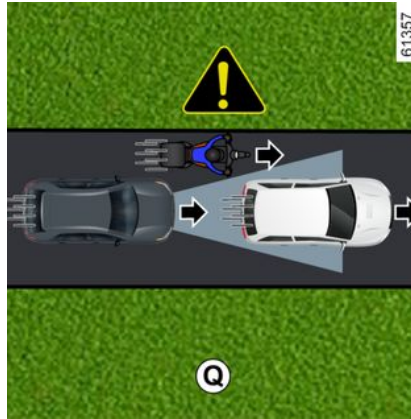
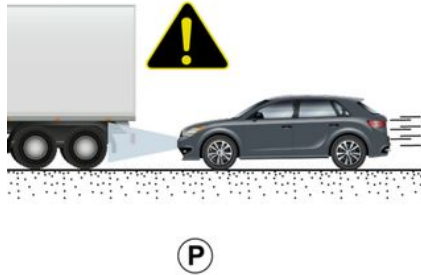

The system will react late or not at all if the detected vehicles are outside the camera and radar detection areas, particularly in the following cases:

- vehicles transporting long objects which exceed the line;
- the actual length of tall vehicles (e.g. **P**) is outside the radar detection area (construction machine, agricultural equipment towing vehicle, etc.);
- vehicles insufficiently centred in the lane;
- narrow vehicles which are very close (e.g. **Q**).

Stationary and slow moving vehicles

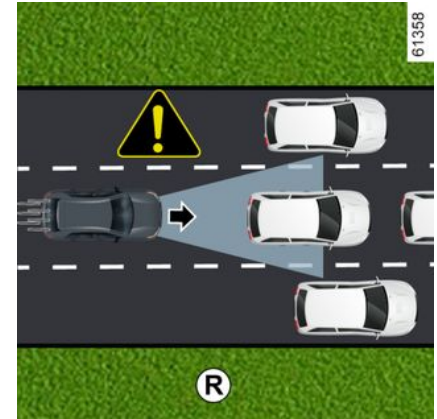

When your speed is over approximately 31 mph (50 km/h), **the system does not detect**:

- stationary vehicles (e.g. **R**);
- very slow moving vehicles.

When your speed is less than approximately 31 mph (50 km/h), **the system may not react or may react very late** to:

- stationary vehicles (e.g. **R**);
- very slow moving vehicles;

ADAPTIVE CRUISE CONTROL



Always be ready to take control of your vehicle when you come upon stationary or very slow-moving vehicles (example *R*).

The adaptive cruise control does not trigger an emergency stop and its braking capability is limited.

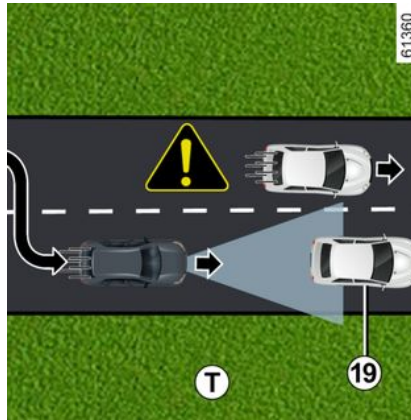
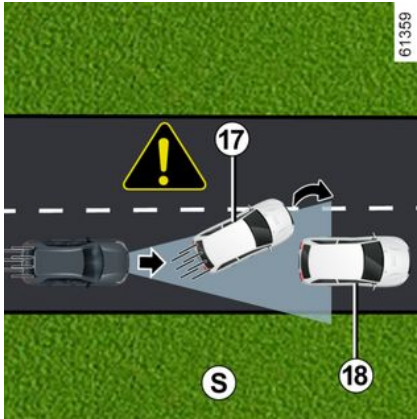

- vehicles in front **17** that change lane, discovering a stationary vehicle **18** (e.g. **S**);
- stationary vehicles **19**, when you change lane (e.g. **T**).

Non-detection of fixed obstacles and objects of a small size

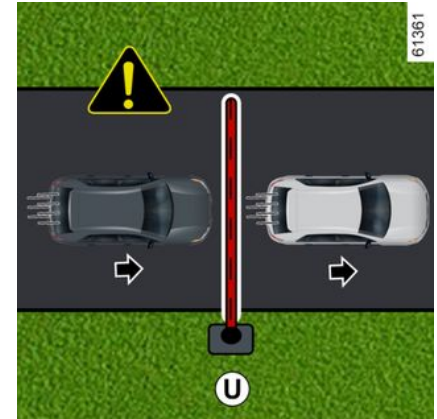

The system cannot detect:

- pedestrians, bikes, scooters, etc.;
- animals;
- fixed obstacles (toll barriers, walls, etc.) (e.g. **U**).

These are not taken into account by the system. They do not trigger any alert or reaction by the system.

ADAPTIVE CRUISE CONTROL

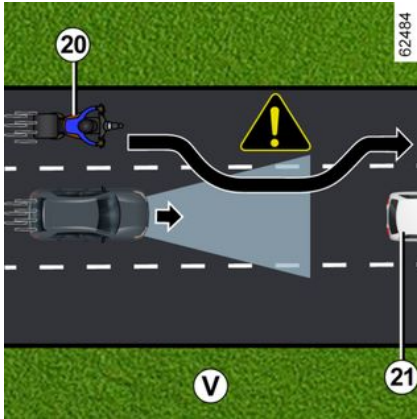

Detection of vehicles moving into lane at high speed

When your vehicle is overtaken by another vehicle driving at high speed **20** (motorcycle, car, etc.) (example **V**) and that vehicle temporarily moves in between you and the vehicle in front **21**, the system may trigger undue acceleration, slowing or braking.

ADAPTIVE CRUISE CONTROL

Warning



This function is an additional driving aid. It can under no circumstances replace the driver's responsibility to respect speed limits and safe distances or to be vigilant.

The driver must always be in control of the vehicle.

The driver must always adapt their speed to the surroundings and driving conditions, regardless of system indications. Except for lines delimiting lanes, traffic indicators (traffic lights, signs, pedestrian crossings etc.) are not recognised by the system. These do not trigger any alert or reaction by the system.

The system should under no circumstances be taken to be an obstacle detector or an anti-collision system.

The adaptive cruise control must only be used on a motorway (or multi-lane road separated by a barrier).

System servicing/repairs

- In the event of an impact, the radar and/or camera alignment may be changed and its operation may consequently be affected. Deactivate the system and consult an authorised dealer.
- Any work in the proximity of the radar and/or camera (replacements, repairs, windscreen modifications, paintwork etc.) must be carried out by a qualified professional.

Only an authorised dealer is qualified to service the system.

ADAPTIVE CRUISE CONTROL



Deactivating the function

You must deactivate the function if:

- the vehicle is travelling on a winding road;
- the vehicle is being towed (breakdowns);
- the vehicle is towing a trailer or a caravan;
- the vehicle is being driven in a tunnel or close to a metallic structure;
- the vehicle arrives at a toll point, a roadwork area or on a narrow lane;
- the vehicle is being driven up or down a very steep slope;
- the visibility is poor (glaring sun, fog, etc.);
- the vehicle is being driven on a slippery road surface (rain, snow, gravel, etc.);
- the weather conditions are poor (rain, snow, side winds, etc.);
- the radar area has been damaged (impacts, etc.);
- the camera area has been damaged (e.g. on the inside or outside of the windscreen);
- the windscreen is cracked or distorted.

In the event of the system behaving abnormally, deactivate it and consult an authorised dealer.

ADAPTIVE CRUISE CONTROL



In the event of system disturbance

Some conditions can disturb or damage the system's operation, such as:

- the windscreen or the radar area is obscured (by dirt, ice, snow, condensation, number plate, etc.);
- a complex environment (tunnel, etc.);
- poor weather conditions (snow, heavy rain, hail, black ice, etc.);
- poor visibility (night, fog, etc.);
- poor contrast between the vehicle preceding it and the surrounding area (e.g. white vehicle in a snowy area, etc.);
- being dazzled (glaring sun, lights of vehicles travelling in the opposite direction; etc.);
- narrow, winding or undulating road (tight bends, etc.);
- a slower vehicle with a significant difference in speed;
- use of mats not adapted to the vehicle. On the driver's side, only use mats suitable for the vehicle, attached with the pre-fitted components, and check the fitting regularly. Do not lay one mat on top of another. **There is a risk of wedging the pedals.**

In these cases, the system may wrongly intervene.

Risk of unwanted braking or acceleration.

Many unforeseen situations may affect the system operation. Certain objects or vehicles that can appear in the camera or radar detection zone may be interpreted by the system incorrectly, possibly leading to inappropriate acceleration or braking.

You should always be attentive to sudden events that might occur while you are driving. Always keep your vehicle under control by keeping your feet near the pedals, so that you are ready to act in any event.

PARKING AIDS

Parking distance control

Operating principle

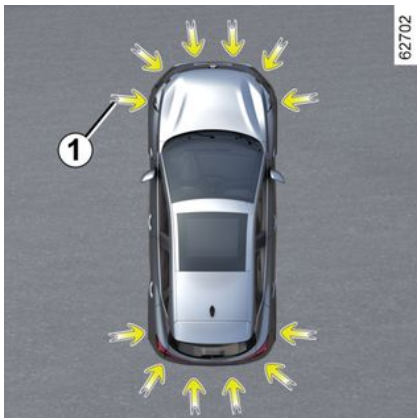

Ultrasonic sensors, indicated by arrows **1**, are fitted in the bumpers to detect obstacles near the vehicle.

The function alerts the driver via audible signals and a display representing the area where the obstacle was detected.

Depending on the equipment, the system detects obstacles behind, in front and to the sides of the vehicle.

The Park Assist system is only activated when the vehicle is driven at a speed below approximately 6 mph (10 km/h).

The function does not take into account towing or carrying systems that are not recognised by the system.



This function is an additional driving aid. Under no circumstances should it replace the driver's care or responsibility whilst reversing.

The driver should always be ready for sudden incidents while driving: always ensure that there are no small, narrow moving obstacles (such as a child, animal, pushchair, bicycle, stone, post, etc.) in the blind spot when manoeuvring.



An impact to the underside of the vehicle while manoeuvring (e.g. striking a post, raised kerb or other street furniture) may result in damage to the vehicle (e.g. deformation of an axle). To avoid any risk of accident, have your vehicle checked by an approved dealer.

Location of the ultrasonic sensors **1**

Ensure that the area around the ultrasonic sensors indicated by the arrows **1** is not obscured (by dirt, mud, snow, a badly fitted/attached number plate), impacted, modified (including paintwork) or obstructed by any accessory fitted to the rear and, depending on the vehicle, to the front or sides of your vehicle.

PARKING AIDS

Operation

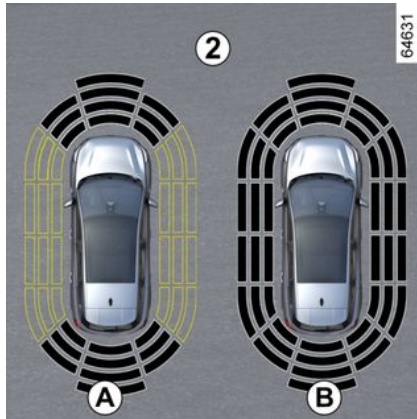

The display **2** shows the vehicle surroundings and emits beeps. Depending on the equipment, it may be necessary to travel a few metres before the side detection is activated. If all areas have a grey background, the whole area around the vehicle is being monitored:

- Display **A**: analysis of vehicle surroundings in progress;
- Display **B**: analysis of vehicle surroundings complete.

Obstacle detection

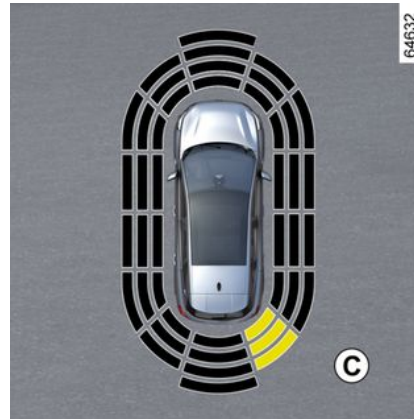

The system is able to detect most obstacles located near the rear and, depending on the equipment, near the front and sides of the vehicle. The audible signal frequency will increase as the vehicle approaches an obstacle, until it becomes a solid beep at approximately 20 cm for an obstacle detected on the sides and approximately 30 cm for an obstacle detected to the front or rear. The area where the obstacle has been detected is displayed (display **C**). Depending on the vehicle, the area is displayed in green, orange (or yellow depending on the vehicle) or red, de-

pending on the proximity of the detected obstacle.

Special case of obstacles on the side

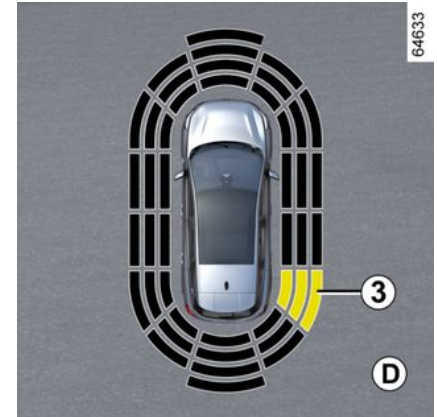

Depending on the direction of the wheels, the system determines the trajectory of the vehicle and notifies the driver if there is a risk or not of a collision with an obstacle **3** to the side of the vehicle. If a side obstacle is detected:

- the beeps become faster and then sound continuously as the obstacle gets nearer. The area where the obstacle **3** has been detected is displayed (display **D**);

PARKING AIDS

– if there is no risk of collision, no beep will sound when approaching the obstacle. Depending on the vehicle, the area where the obstacle **3** has been detected is shown interspersed.

3



In the event of a change in trajectory during a manoeuvre, the risk of collision with an obstacle may be signalled late.

Activation/deactivation

Activating/deactivating the system from the multimedia screen **4**



From the "Vehicle" world on your multimedia screen **4**, press the "Parking assistance" menu.

Activate or deactivate areas covered by the ultrasonic detectors.

Please refer to the multimedia instructions for more information.

Note: depending on the vehicle, the rear detection zone cannot be deactivated.

Automatic deactivation of parking distance control

The system is deactivated:

- when the vehicle speed is above approximately 6 mph (10 km/h);
- depending on the vehicle, when the vehicle is stationary for more than approximately three seconds and an obstacle is detected (such as when in a traffic jam, etc.);
- when you are in **N** or **P** position;
- when an operating fault is detected.

Note: depending on the vehicle, if the vehicle is fitted with a towbar recognised by the system, only the rear Park Assist function is deactivated.

Adjustment



For safety reasons, carry out any adjustments while the vehicle is stationary.



Each time the vehicle is started, the function resumes the activation status saved the last time the engine was stopped.

With the vehicle stationary, from the "Vehicle" world on your multimedia screen **4**, press the "Parking assistance" menu.

Please refer to the multimedia instructions for further information.

Deactivating the system sound

(depending on the vehicle)

Activate or deactivate the parking distance control sound.

Note: if you mute the sound, when approaching an obstacle you will be alerted only by the display.

PARKING AIDS

Park Assist sound volume

Adjust the Park Assist volume using the volume bar



Each time the vehicle is started, the function resumes the activation status saved the last time the engine was stopped.

system does not produce a sound or display when the reverse gear is engaged.

Check that the ultrasonic sensors are clean. If the fault persists, consult an approved Dealer.

Special cases

You can manually deactivate sound alerts or, depending on the vehicle, the detection zone concerned in the event that:

- any towing, carrying or trailer equipment that is unrecognised by the system is present in front of the ultrasonic sensors;
- the ultrasonic sensors are damaged.

Note: even if the sound is muted, the displays will continue to warn you.

Operating faults

When the system detects a malfunction: either a sound signal warns you for about three seconds when the reverse gear is engaged, accompanied by the "Check Parking sensors" message on the instrument panel, or the

PARKING AIDS

Advice



When the vehicle is travelling at a speed below approximately 6 mph (10 km/h), some noises (motorcycle, lorry, pneumatic drill, etc.) may trigger the Park Assist system audible warnings.



System servicing/repairs

- In the event of an impact, the alignment of the ultrasonic sensors may be altered and its operation may consequently be affected. Deactivate the function and consult an authorised dealer.
- Any work in the area where the ultrasonic sensors are located (repairs, replacements etc.) must be carried out by a qualified professional.

Only an authorised dealer is qualified to service the system.

System disturbance

Some conditions can disrupt or damage the system operation, for example:

- poor weather conditions (rain, snow, hail, black ice, etc.);
- some types of noise (motorcycle, lorry, pneumatic drill, etc.);
- fitting an non-compatible towing ball or hook.

Risk of false alarms or absence of warnings

If the system behaves abnormally contact an authorised dealer.

PARKING AIDS



Limitation of the system operation

- The ultrasonic detection zones should be kept clean and free of any modifications in order to ensure the proper operation of the system.
- Small objects moving close to the vehicle (motorcycles, bicycles, pedestrians, etc.) may not be recognised by the system.
- The system may not detect obstacles that are too close to the vehicle.
- The system may not provide a warning when the other vehicles or obstacles are travelling at a significantly different speed.
- During a change in trajectory during a manoeuvre, the system may report obstacles with a delay.

PARKING AIDS

Reversing camera

Operation



When reverse gear is engaged, the camera **1** located at the rear of the vehicle transmits a view of the area behind the vehicle to the multimedia display **2** accompanied by three guide lines **3**, **4** or **5** (fixed, moving and trailer guide lines).

This system uses several guidelines for its operation (mobile for trajectory and fixed for distance). When the red zone is reached, use the bumper image to stop accurately.



Fixed guide lines **3**

The fixed gauge includes coloured markers **A**, **B** and **C** indicating the distance behind the vehicle:

- **A** (red) at approximately 30 centimetres from the vehicle;
- **B** (yellow) at approximately 70 centimetres from the vehicle;
- **C** (green) at approximately 150 centimetres from the vehicle.

This gauge remains fixed and indicates the vehicle trajectory if the wheels are in line with the vehicle.

Moving guide lines **4**

This is shown in blue on the multimedia screen **2**. It indicates the vehicle trajectory according to the position of the steering wheel.

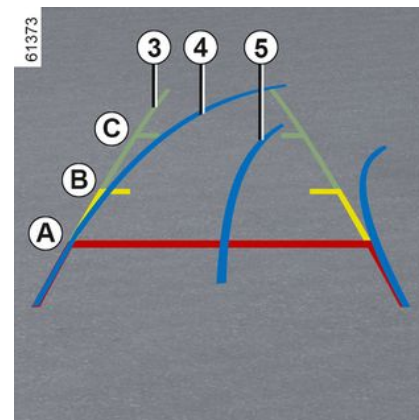

Trailer guide lines **5**

This is shown in blue on the multimedia screen **2**. This indicates the trajectory of the trailer towbar according to the steering wheel position. It allows the driver to position the towbar as close as possible to the trailer's towing head.

« Trailer view »

If a trailer is connected, while in a forward gear press the "Camera" menu in the "Vehicle" world on your multimedia screen **2** to enable the camera **1** to transmit a view of the rear environment during approximately 30 seconds.

PARKING AIDS

Settings



When the reverse gear is engaged, from the multimedia screen press the "Settings" button to add or remove the guide lines and adjust the camera image settings (brightness, contrast, etc.).

Please refer to the multimedia instructions for further information.

"Zoom auto" function

If an obstacle is detected behind the vehicle, the function "Zoom auto" switches the current display to a top rear view.

To activate/deactivate the "Zoom auto" function, refer to the multimedia instructions.

 Make sure that the camera is not obscured (by dirt, mud, snow, condensation etc.).

 The screen shows a reverse mirror image. The frames are a representation projected on a flat surface. This information is to not be taken into account when superimposed on a vertical object or an object on the ground. Objects which appear on the edge of the screen may be deformed. In very bright light (snow, vehicle in sunshine, etc.), the camera vision may be adversely affected. If the luggage compartment is open or incorrectly closed, the "Luggage compartment open" message appears.

Operating faults

When reverse gear is engaged, if the system detects an operating fault, a black screen is displayed temporarily on the multimedia screen **2**.

This may be caused by a fault affecting the camera or screen (clearness, fixed image, delayed communication etc.).

If the temporary display of the black screen persists, please consult an approved dealer.



This function is an additional aid. It cannot, therefore, under any circumstances replace the vigilance or the responsibility of the driver.

The driver should always be ready for sudden incidents while driving: always ensure that there are no small, narrow moving obstacles (such as a child, animal, pushchair, bicycle, stone, post, etc.) in the blind spot when manoeuvring.

PARKING AIDS

Difference between the estimated distance and actual distance

Driving or reversing towards a steep uphill slope

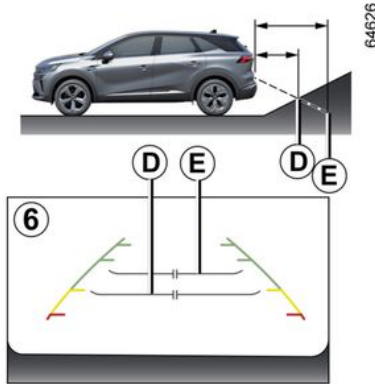

The fixed guidelines **6** show the distances as closer than they actually are. The objects shown on the screen are actually further away on the slope. For example, if the screen displays an object at **D**, the actual distance of the object is at **E**.

Driving or reversing towards a steep downhill slope

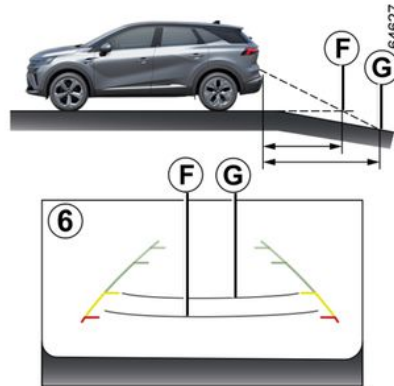

The fixed guidelines **6** show the distances as further than they actually are.

Therefore, the objects shown on the screen are actually closer on the slope.

For example, if the screen displays an object at **G**, the actual distance of the object is at **F**.

Driving or reversing towards a protruding object

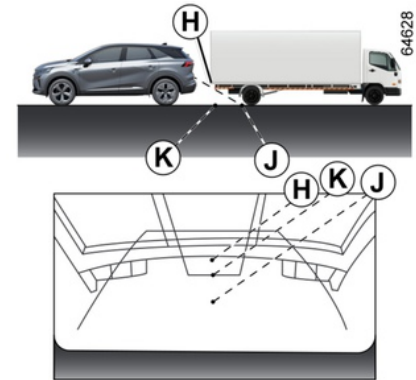

Position **H** seems further than position **J** on the screen. However, position **H** is at the same distance as position **K**.

The trajectory indicated by the fixed and mobile guidelines do not take into account the height of the object. So there is a risk that the vehicle may collide with the object when reversing towards position **K**.

PARKING AIDS

Hands-free parking

Introduction

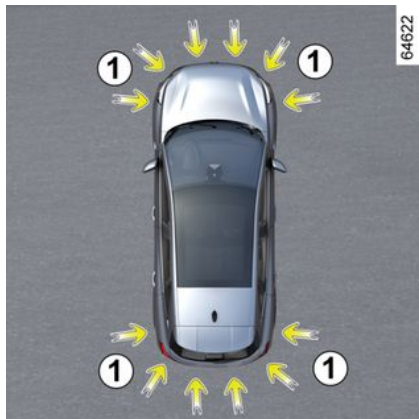

As indicated by the arrows **1**, the ultrasonic detectors installed in the vehicle bumpers help to find accessible parking spaces and assist the parking manoeuvre.

Remove your hands from the steering wheel, you only control:

- the accelerator pedal;
- the brake pedal;
- the gear lever.

At any time, you can regain control by using the steering wheel.



This function is an additional driving aid.

Under no circumstances should it replace the driver's care or responsibility whilst reversing.

The driver should always be ready for sudden incidents while driving: always ensure that there are no small, narrow moving obstacles (such as a child, animal, pushchair, bicycle, stone, post, etc.) in the blind spot when manoeuvring.



An impact to the underside of the vehicle while manoeuvring (e.g. striking a post, raised kerb or other street furniture) may result in damage to the vehicle (e.g. deformation of an axle).

To avoid any risk of accident, have your vehicle checked by an approved Dealer.

Location of the ultrasonic sensors **1**

Ensure that the area around the ultrasonic sensors indicated by the arrows **1** is not obscured (by dirt, mud, snow, a badly fitted/attached number plate, etc.), impacted, modified (including paintwork) or obstructed by any accessory fitted to the rear and, depending on the vehicle, to the front or sides of your vehicle.

Switching on

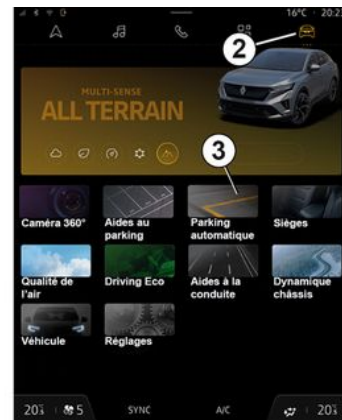

PARKING AIDS



With the vehicle stationary or driving at less than approximately 19 mph (30 km/h), there are several ways to access the function:

- from the multimedia screen **4**, "Vehicle" world **2**, press the "Driving assistance" menu **3** then the "Parking" tab to access the parking aids menu;
- via the "Hands-free parking" widget (if previously configured);
- via the "Favourites" button on the steering wheel (if previously configured).

Please refer to the multimedia instructions for more information.

Choice of manoeuvre

The system can perform three types of manoeuvre:

- parking the vehicle in a parallel or perpendicular parking space;
- moving out of a parallel parking space.

From the multimedia screen **4**, select the manoeuvre to carry out using the display.

Note: when starting the vehicle, or after having successfully completed parallel parking using the system, the default manoeuvre proposed by the system is assistance in exiting a parallel parking space.

In other cases, the default manoeuvre can be set from the multimedia screen **4**.

Please refer to the multimedia instructions for further information.

 The system start up is accompanied by activation of the parking distance control and, on those vehicles equipped, the reversing camera or 360° camera to help the driver visualise the manoeuvre → **252**, → **258**, → **266**.

Operation



This function is an additional driving aid.

Therefore, it can under no circumstances replace the driver's vigilance and responsibility during manoeuvres (the driver must always be ready to brake).



When manoeuvring, the steering wheel may turn quickly: do not put your hands inside and make sure that nothing is caught inside.

Parking the vehicle in a parallel or perpendicular parking space

As long as the vehicle speed is less than 19 mph (30 km/h), the system looks for available parking spaces on both sides of the vehicle.

Once a space has been found, it is displayed on the multimedia screen **4**, indicated by the letter "P". Drive slowly until the "STOP" message appears, accompanied by a beep. If several spaces are detected on either side of

PARKING AIDS

the vehicle, you must select the desired space by activating the direction indicator. If the spaces are on the same side of the vehicle, only the last space detected by the system will be taken into account.

The space turns to grey on the multimedia screen **4** and is marked by the letter "P".

- Stop the vehicle;
- select reverse gear.

The  warning light is displayed on the instrument panel and a beep sounds.

- Let go of the steering wheel;
- follow the system instructions on the multimedia screen **4**.

Your speed should not exceed around 4 mph (7 km/h).

Once the warning light  on the instrument panel goes off and a beep sounds, the manoeuvre has been completed.

Exiting a parallel parking space

- Activate the "Hands-free parking" function;
- select the "Exit parallel parking space" mode;

- activate the direction indicator lights on the side on which you wish to exit the vehicle;

If all conditions are met, a message will appear on the multimedia screen **4** to start the manoeuvre.

- press "OK" to start.

The indicator light  lights up on the instrument panel and a beep sounds.

- Let go of the steering wheel;
- carry out forward and backward manoeuvres following the instructions shown on the multimedia screen **4** and using the alerts provided by the Park Assist system.

Your speed should not exceed around 4 mph (7 km/h).

Once the vehicle is in a position to exit the parking space, the warning light

 disappears from the instrument panel accompanied by a beep and a message appears on the multimedia screen **4** to confirm that the manoeuvre is complete.

Suspending/Resuming the manoeuvre

The manoeuvre is suspended in the following cases:

- the vehicle is stationary for too long;
- an obstacle in the direction of movement prevents the manoeuvre from being completed;
- the engine stops;
- a door or the luggage compartment is opened.

The  warning light disappears from the instrument panel accompanied by a beep to inform you that the manoeuvre has been suspended. The "Park manoeuvre suspended" message and the reason for interrupting the manoeuvre will be displayed on the multimedia screen **4**.

Make sure:

- you have let go of the steering wheel;
- and
- that all doors and the luggage compartment are closed;
- and
- that no obstacles are in the way of the direction of movement;
- and
- that the engine is started.

If the  warning light flashes, this indicates that the system is once again available to resume the manoeuvre.

PARKING AIDS

To resume the manoeuvre, press the "Parking aids" menu. Warning light



comes on the instrument panel.

Follow the instructions shown on the multifunction screen 4.

3

Cancelling the manoeuvre

The manoeuvre is cancelled in the following cases:

- you take control of the wheel;
- the vehicle is stationary for too long;
- the parking brake is applied;
- the vehicle speed has exceeded 4 mph (7 km/h);
- the vehicle wheels have skidded;
- the engine start/stop button is pressed;
- via the multimedia screen;
- the instructions given on the multimedia screen are not followed;
- the driver's seat belt is unfastened;
- the driver's door is opened;
- you have performed more than ten forwards/backwards movements in one manoeuvre;
- the parking distance control sensors are dirty or obscured.

The  warning light disappears from the instrument panel accompanied by a beep to warn you that the manoeuvre has been aborted. The

reason for cancelling the manoeuvre will be displayed on the multimedia screen 4.

Function unavailable

When you select one of the system activation methods, if the operating conditions are not met, the "Hands-free parking unavailable" message is displayed on the instrument panel to warn you that the function is unavailable.

Operating faults

When the function detects an operating fault, the following messages are displayed on the instrument panel:

- "Check Park Assist", accompanied

by the warning light .

or

- "Check parking sensors";

or

- "Check Parking Aids".

Clean the ultrasonic sensors. If there is still a problem, contact an approved dealer.

Note: if there is a fault with the function, the vehicle is not immobilised.

Take control of the vehicle again immediately.

PARKING AIDS

Warnings



This function is an additional driving aid. This function is not under any circumstances intended to replace the due care and attention of the driver, who should at all times be in control of the vehicle. Make sure that the manoeuvre complies with the applicable traffic regulations in your location.

The driver should always be ready for sudden incidents while driving: always ensure that there are no small, narrow moving obstacles (such as a child, animal, pushchair, bicycle, stone, post, towing equipment, etc.) in the blind spot when manoeuvring.

System servicing/repairs

- In the event of an impact, the operation of the sensors may be affected. Deactivate the function and consult an authorised dealer.
- Any work in the area where the sensors are located (repairs, replacements, exterior trim modifications, etc.) must be carried out by a qualified professional.

Only an authorised dealer is qualified to service the system.

In the event of system disturbance

Certain conditions may disrupt or impair operation of the system, such as poor weather conditions (snow, hail, ice, etc.).

In the event of the system behaving abnormally, deactivate it and consult an authorised dealer.

Risk of erroneous false alarms.

Limitations of the system operation

- The system cannot detect objects located in the sensor blind spots.
- Always look to check that the parking space suggested by the system is actually still available and free from obstacles before and during the entire manoeuvre.
- The system must not be used when towing a trailer or when there is a towing or load carrying system on the vehicle or on surrounding vehicles.

PARKING AIDS

360° camera

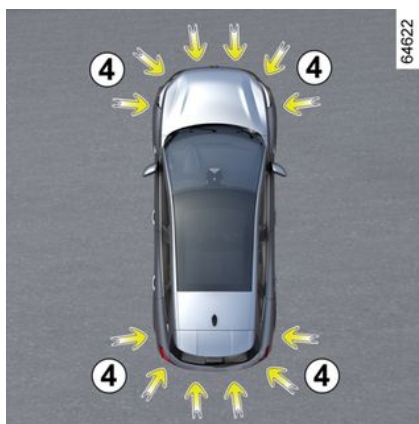
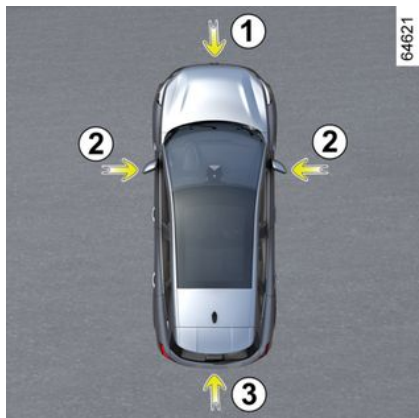

Using information from cameras **1**, **2** and **3** located in the front bumper, door mirrors and on the tailgate, as well as ultrasonic detectors **4** located in the vehicle bumpers, the feature assists with difficult manoeuvres (e.g. parking) by displaying the vehicle surroundings.

Note: make sure that the cameras are not obscured (by dirt, mud, snow, condensation, etc.).

Operation



The cameras transmit several separate views to the multimedia screen **5**. They enable you to view the vehicle surroundings:

- front view (using camera **1**) + bird's-eye view (using cameras **1**, **2** and **3**): standard front view and panoramic front view + standard bird's-eye view;
- rear view (using camera **3**) + bird's-eye view (using cameras **1**, **2** and **3**): standard rear view and panoramic front view + standard bird's-eye view;
- front or rear view (using camera **1** or **3**) + side view (using camera **2**): front/rear view + passenger side view.

The ultrasonic detectors detect obstacles at the front, rear and (depending on the vehicle) side of the vehicle.

Front camera 1



The front camera view is displayed on the multimedia screen **5**.

PARKING AIDS



This function is an additional aid. It cannot, therefore, under any circumstances replace the vigilance or the responsibility of the driver.

The driver should always be ready for sudden incidents while driving: always ensure that there are no small, narrow moving obstacles (such as a child, animal, pushchair, bicycle, stone, post, etc.) in the blind spot when manoeuvring.

Rear camera 3



The rear camera view is displayed on the multimedia screen **5**.



For the rear views, the multimedia screen **5** shows a reverse image of the rear view as in a rear view mirror.



In front view or rear view: when manoeuvring on a slope, objects shown on the multimedia screen may be closer or further away than they seem.

Take this into account in order to correctly assess the distance before any manoeuvre.

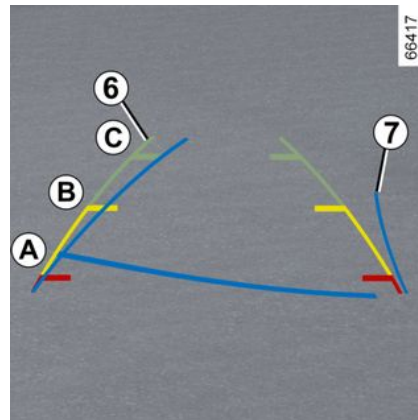

The "front" or "rear" view re-transmitted to the multimedia screen **5** is displayed with one, two or three guide lines **6** and **7**.

PARKING AIDS

This system is initially used with the aid of several gauges (mobile and trailer for trajectory and fixed for distance).

Fixed guide lines 6

The fixed gauge includes coloured markers **A**, **B** and **C** indicating the distance behind the vehicle:

- **A** (red) at approximately 30 centimetres from the vehicle;
- **B** (yellow) at approximately 70 centimetres from the vehicle;
- **C** (green) at approximately 150 centimetres from the vehicle.

Moving guide line 7

This is shown in blue on the multimedia screen **5**. It indicates the vehicle trajectory according to the position of the steering wheel in the front and the rear view.



The front, rear and side view guidelines are a representation projected onto flat ground; this information must not be taken into account when superimposed on a vertical object or an object on the ground. Objects displayed on the edge of the multimedia screen may appear distorted.

In very bright light (snow, vehicle in sunshine, etc.), the camera vision may be adversely affected.



In the combined representation from the cameras:

- raised objects (pavement, vehicle, etc.) may appear distorted in the bird's eye view;
- any objects on top of the vehicle are not displayed.

Front side view 2

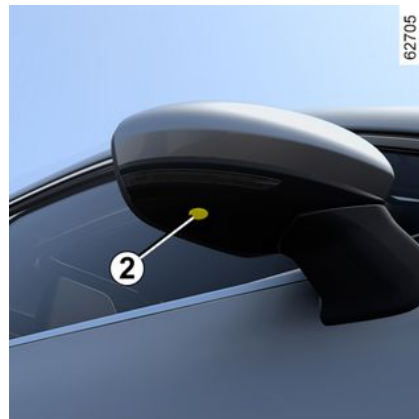

Camera **2**, fitted in the door mirror, transmits a side view to the multimedia screen **5**.

Depending on the vehicle, you can use the multimedia screen to change the bird's eye view to the front side view. Please refer to the multimedia instructions for further information.

PARKING AIDS

Bird's eye view



61447

The bird's eye view is a combined representation from cameras **1**, **2** and **3**. It displays a view of the top of the vehicle and its surroundings.

This can be used to confirm a view of the vehicle position in relation to its immediate surroundings (front, rear and side).



In "bird's eye view" mode, the objects displayed on the multimedia screen are actually further away than they seem.

Take this into account in order to correctly assess the distance before any manoeuvre.

Obstacle detection

While the system is activated, if the "Park Assist" function detects one or more obstacles around the vehicle, the indicator **12** is displayed on the various views.

In addition to the audible warning, these indicators show the proximity of obstacles via different colours:

- green: obstacle between approximately 50 and 70 cm;
- yellow: obstacle between approximately 30 and 50 cm;
- red: obstacle within approximately 30 cm.

These indicators also show the locations where obstacles are detected, as indicated by their positions in relation to the "Vehicle" symbol.

For more information → **252**.

Activation/deactivation



62623

3

Automatic mode

With the vehicle stationary and the engine running, automatic mode is activated when the reverse gear is engaged. The rear view and the bird's eye view appear on the multimedia screen **5**.

When the reverse gear is quickly shifted to forward gear, the rear view and bird's eye view are replaced by the front view and bird's eye view on the multimedia screen **5**.

Automatic mode is deactivated:

- when the gear lever is in neutral position (manual gearbox) or in N or P

PARKING AIDS

position (automatic gearbox) for approximately three seconds;

- when the vehicle speed moving forward exceeds 6 mph (10 km/h).

Manual mode

To activate manual mode, with the vehicle stationary and the engine on, from the "Vehicle" world on your multimedia screen **5**, press the "360° camera" menu and the front view and bird's eye view will appear on the multimedia screen.

Manual mode is deactivated:

- when the vehicle speed moving forward reaches 6 mph (10 km/h);
- when the gear lever has not been used for approximately three minutes.



- Do not use this function while the door mirrors are in folded position.
- Ensure that the luggage compartment door is properly closed before using the function.
- Do not place any objects on or in front of the cameras.

Difference between the estimated distance and actual distance

Driving or reversing towards a steep uphill slope

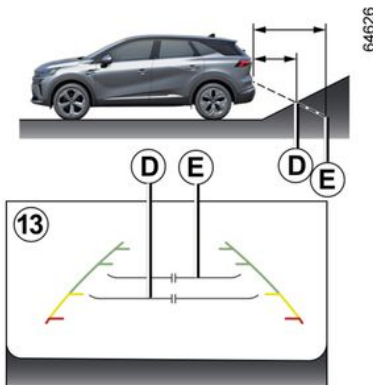

The fixed guidelines **13** show the distances as closer than they actually are. The objects shown on the screen are actually further away on the slope. For example, if the screen displays an object at **D**, the actual distance of the object is at **E**.

Driving or reversing towards a steep downhill slope

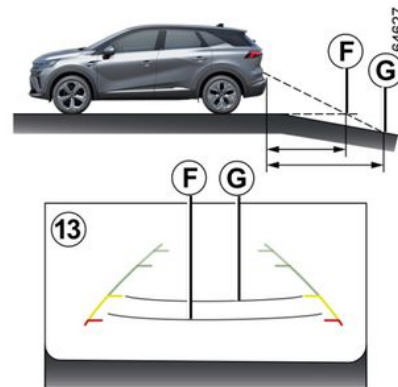

The fixed guidelines **13** show the distances as further than they actually are.

Therefore, the objects shown on the screen are actually closer on the slope.

For example, if the screen displays an object at **G**, the actual distance of the object is at **F**.

PARKING AIDS

Driving or reversing towards a protruding object

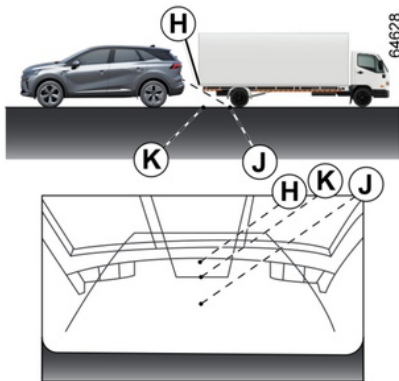

Position **H** seems further than position **J** on the screen. However, position **H** is at the same distance as position **K**. The trajectory indicated by the fixed and mobile guidelines do not take into account the height of the object. So there is a risk that the vehicle may collide with the object when reversing towards position **K**.

Limitation of the system operation

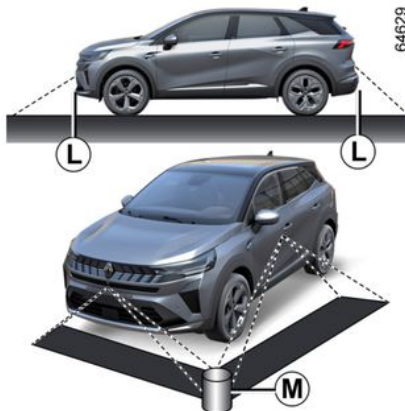

The system is unable to display objects located in certain areas. In the front or rear view mode, the system cannot be used to view an object in area **L**. In bird's eye view mode, the system cannot be used to view a large object in area **M** (near the edge of the displayed area).

Adjusting the display



From the multimedia screen, when the "360° camera" system is displayed, you can change the views (e.g. replace the bird's eye view by the rear side view).



For safety reasons, carry out any adjustments while the vehicle is stationary.

If the gear lever is in **R** position (on an automatic gearbox) or in reverse gear (on a manual gearbox), the following views are available:

PARKING AIDS

– screen split between the rear view/
bird's eye view;

or

– screen split between the rear view/
front side view (depending on the vehicle).

When shifting from reverse gear to **P**
position (on an automatic gearbox) or
to neutral position (on a manual gearbox),
the following views are available:

– screen split between the rear view
and the bird's eye view;

or

– screen split between the rear view/
front side view (depending on the vehicle).

When shifting from reverse gear to **D**
position (on an automatic gearbox) or
to any gear (on a manual gearbox), the
following views are available:

– screen split between the front view
and the bird's eye view;

or

– screen split between the front view/
front side view (depending on the vehicle).

Parking exit warning

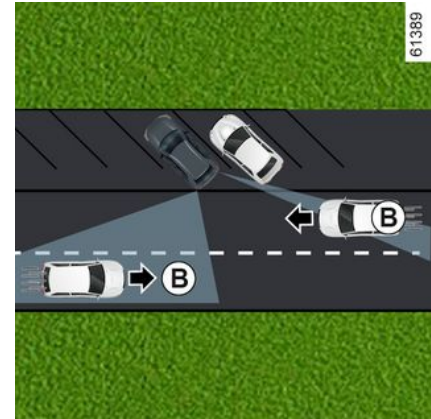
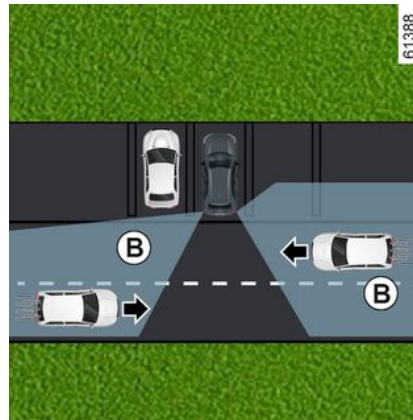



Using information from the radars installed on each side of the rear bumper (zone **A**), the system notifies the driver when another vehicle appears in the detection zone **B**.

The function is activated if:

- the reverse gear is engaged;
- and
- the vehicle is stationary or driving at a low speed.

PARKING AIDS

 The system's detection capability depends on the vehicle's surroundings (static objects etc.) and the condition of the bumper etc.

 This function is an additional driving aid. This function is not under any circumstances intended to replace the due care and attention of the driver, who should at all times be in control of the vehicle.

Special feature

Make sure that the radar area **A** is not obscured (by stickers, mud, snow, etc.).

If one of the radars is obscured, the "Side radars without visibility" message is displayed on the instrument panel. Clean the area where the sensors are located.

Activation/deactivation from multimedia screen 1



To activate or deactivate the function, refer to the multimedia instructions.

Select "ON" or "OFF".

Operation



The function warns you if a vehicle is in area **B** and is approaching your vehicle.

When a vehicle is detected, the warning lights **2** light up on both door mirrors **3**.

Note: clean the door mirrors regularly **3** so that the warning lights **2** can be seen.

PARKING AIDS

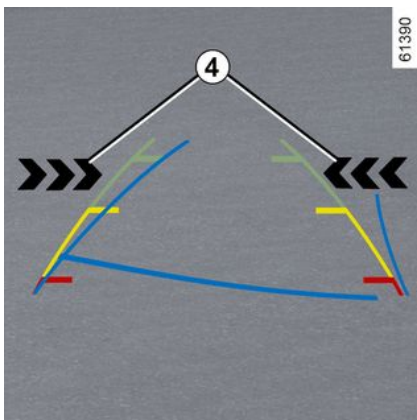

The warning lights **4** on the multimedia screen indicate the side on which the approaching vehicle has been detected.

Note: clean the camera regularly so that it is not obscured.

Warning lights **2** and **4** are accompanied by an audible warning when reverse gear is engaged and your vehicle is moving.

If the vehicle is fitted with a towbar recognised by the system and a trailer has been connected, the parking exit warning is automatically deactivated. The "Driving assist unavailable" message is displayed on the instrument panel to warn you.

Operating faults

When the system detects a fault, the "Check side radars" message is displayed on the instrument panel. Consult an approved dealer.

i Due to the presence of sensors behind the bumper, it is advisable to entrust any operation on the bumper (repair, replacement, paintwork, etc.) to a qualified professional.

PARKING AIDS

Limitations to system operation



Limitation of the system operation

- The radar area should be kept clean and free of any modifications in order to ensure the proper operation of the system.
- Small objects (motorcycles, bicycles, pedestrians etc.) moving towards to the vehicle may not be recognised by the system.

Deactivating the function

You must deactivate the function if:

- the radar area **A** has been damaged (rear bumper);
- the vehicle is fitted with a towbar that is not recognised by the system.

PARKING AIDS

Warnings



This function is an additional driving aid. This function is not under any circumstances intended to replace the due care and attention of the driver, who should at all times be in control of the vehicle.

The system should under no circumstances be taken to be an obstacle detector or an anti-collision system.

System servicing/repairs

- In the event of an impact, the position of the radars may be changed, affecting the function. Deactivate the function and consult an authorised dealer.
- Any work in the area where the radars are located (repair, replacement, bodywork etc.) must be carried out by a qualified professional.

Only an authorised dealer is qualified to service the system.

System disturbance

Some conditions can disrupt or damage the system operation, for example:

- a complex environment (underground car park, metallic structures, etc.);
- poor weather conditions (snow, heavy rain, hail, black ice etc.).

Risk of false alarms or absence of warnings

In the event of the system behaving abnormally, deactivate it and consult an authorised dealer.

PARKING AIDS

Safe passenger exit

Description

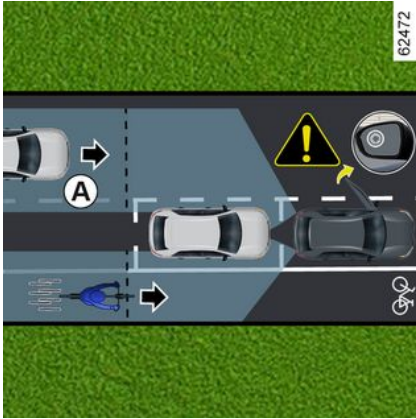

This function is an additional driving aid for the safety of the occupants of the vehicle.

The purpose of the "Safe passenger exit" function is to warn the driver and/or passengers of the potential danger if they open their doors when the vehicle is stationary.

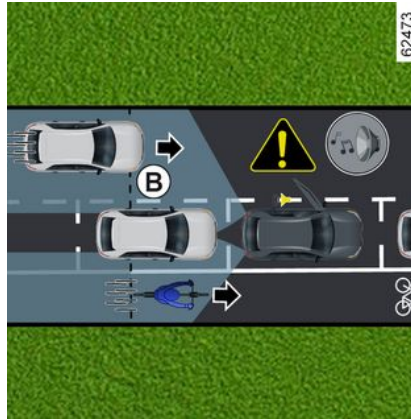

Using information from the sensors installed on each side of the rear bumper (area **C**), the function warns the driver:

- when another vehicle (or motorcycle, bicycle, pedestrian, etc.) is within the detection zone **A**;
- and
- when there is a risk of collision with a vehicle (or motorcycle, bicycle, pedestrian, etc.) in the zone **B**.

Special feature



Ensure that zone **C** around the radars on each side of the rear bumper are not obstructed (by dirt, mud, snow, etc.).

If one of the radars is obscured, the "Side radars without visibility" message is displayed on the instrument panel. Clean the area where the sensors are located.

You must deactivate the function if:

- the radar zone **C** has been damaged (rear bumper);
- the vehicle is fitted with a towbar that is not recognised by the system.

PARKING AIDS

Operation



When a door is opened, when a moving object is detected, the warning light **1** is displayed on the door mirror **2** and, depending on the vehicle, the ambient lights in the front door are illuminated.

Note: clean the door mirrors **2** regularly so that the warning light **1** can be seen.



When the detected object is very close, a beep sounds and is accompanied by the **3** "Side obstacle detected" warning message on the instrument panel.

Note: the system remains active for some time after the ignition has been switched off.

Activating/deactivating the function from the multimedia screen **4**



To activate or deactivate the function, refer to the multimedia instructions.

 When the vehicle is unlocked, the function returns to the last saved status on the multimedia screen.

Conditions for non-function

- the vehicle is moving and is not completely stationary;
- the vehicle is locked from the outside;

PARKING AIDS

- there are moving objects (motor-bikes, bicycles, pedestrians, vehicles, etc.) moving towards or near your vehicle at a low speed that is not considered a risk by the system;
- the range of the sensors located inside the rear bumper is hidden by objects, such as other particularly wide parked vehicles those parked very close to your vehicle.

If the vehicle is equipped with a towbar recognised by the system, the "Driving aids unavailable" message is displayed on the instrument panel to inform you that the function is not operational.

For information on the range of equipment adapted to your vehicle, we advise you to consult an approved Dealer.

Operating faults

When the system detects a fault, the "Check side radars" message is displayed on the instrument panel. Consult an approved dealer.



This function is an additional driving aid and may not detect certain vehicles or objects in

movement in the vicinity of your vehicle. This function is not in any way a substitute for the vigilance and responsibility of the driver and the occupants of the vehicle, who are always responsible for paying particular attention to the traffic situation and checking the area before leaving the vehicle.

In the event of system disturbance

Certain conditions (complex environment, poor weather conditions, etc.) may disrupt or damage the operation of the system, with the risk of false alarms.

EMERGENCY CALL

If the vehicle is equipped, the emergency call function can be used to call the emergency services (without charge) automatically or manually in the event of an accident or illness, reducing the time it takes for the emergency services to arrive.

Note: the emergency call function is operational:

- in countries covered by the associated telephone emergency services and infrastructure compatible with the system;
- depending on the network coverage in the geographical region where the vehicle is being driven.

If you use the emergency call function to report an accident which you have witnessed, this implies stopping where traffic conditions allow in order for the emergency services to locate your vehicle and therefore the location of the reported accident.

In all cases, comply with local legislation.



Use the emergency call only in the event of an emergency you are involved in, if you witness an accident or if you feel ill.

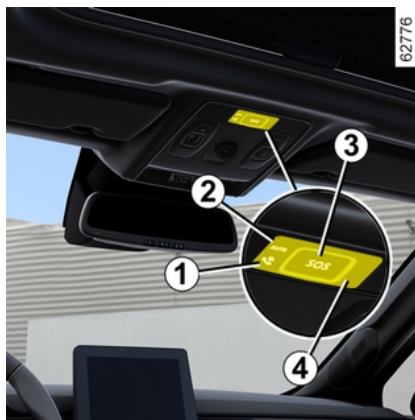

1. System operation warning light:

- green: operational (network available);
- off: non-operational (network unavailable);
- red: operating fault;
- flashing green: call in progress.

2. Automatic mode warning light.

3. SOS button.

4. Microphone.

5. Speaker.



A call always takes place as follows:

- the call is initiated with the emergency services;
- data related to the incident (manufacturer's plate, time of the call, last locations, vehicle direction, etc.) is sent;
- voice communication takes place with the emergency services;
- if necessary, emergency assistance is called.

There are two emergency call modes:

- automatic mode;
- Manual mode.

EMERGENCY CALL



To guarantee your safety and the proper operation of the system, any operation carried out on the battery (removal, disconnection, etc.) must be carried out by a qualified specialist.

Risk of serious burns or electric shocks.

You must respect the replacement intervals (without exceeding them) as stated in the maintenance document.

The battery is a specific type.

Please ensure it is replaced with the same type.

Call an approved dealer.

Automatic mode

If the automatic mode warning light **2** appears in green, this confirms that the automatic system is activated.

The emergency call starts automatically in the event of an accident that has triggered activation of the protective equipment (seat belt pretensioners, airbag, etc.).



In the event of an accident, if the location and traffic conditions permit, stay close to the vehicle in order to be able answer the call centre quickly if necessary.

Manual mode

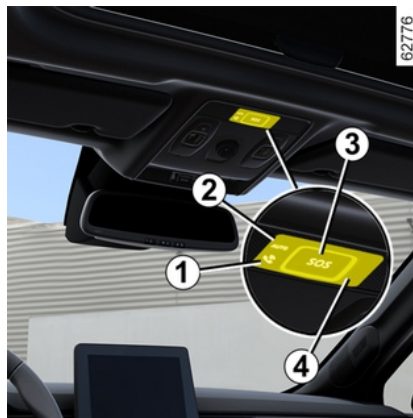

The emergency call can be initiated by:

- pressing and holding the button **3** for at least three seconds;
- or
- pressing the button **3** five times within ten seconds.

If the button was pressed by mistake, it is possible to cancel the call by pressing and holding the button **3** for around two seconds, before the call is connected to the call centre.

Once a call is established, only the call centre can end it.

Operating faults

In some cases, the emergency call may not work (e.g. low battery, etc.).

When the system detects an operating fault, the warning light **1** appears in red for over 30 minutes. Consult an approved dealer as soon as possible.



The system operates with a dedicated battery. The battery service life is approximately four years (the warning light **1** appears in red to warn you).

Consult an approved dealer.

EMERGENCY CALL



Without the emergency call feature, the system is not trackable and will not be under constant surveillance. Data is automatically and constantly erased, and the system stores only the last three positions of the vehicle.

According to local legislation, data is only sent in the event of an emergency call. Data sent to the call centre is treated according to the personal data protection laws applicable in the country where you are located. The system stores activity history data for 13 hours only.

The vehicle owner has the right of access to their data. They can request that the data be corrected, deleted or locked.

MULTI-SENSE

Depending on the vehicle, the MULTI-SENSE system enables you to choose from several driving modes that affect the driving, ambient lighting, comfort and driving position:

- all the modes are preconfigured and can be customised (ambient lighting, etc.);
- the "Perso" mode is customisable.

The driving modes influence:

- steering force;
- the Electronic Stability Program;
- engine responsiveness.

They also influence:

- the lighting in the passenger compartment and on the instrument panel;
- the presentation of the instrument panel and the multimedia screen;
- depending on the vehicle, the driving position.

 Engine settings are specific to each of the driving modes and cannot be customised except for the "Perso" mode.

Accessing the menu



You can access MULTI-SENSE, depending on the vehicle:

- from the multimedia screen **1**;
- using switch **2**.

Please refer to the multimedia instructions for further information.

The selected mode is displayed on the instrument panel **3**.

 After the engine stops, the vehicle will always restart in Comfort mode.

"Custom" mode

This mode allows the complete configuration of the driving elements, including engine responsiveness.

 You can reset the settings for the "Custom" mode. Please refer to the multimedia instructions for more information.

"Eco" mode

The Eco mode focuses on energy saving. The steering is smooth and the engine and gearbox management enable

MULTI-SENSE

the reduction of fuel consumption

➔ 157.

"Sport" mode

This mode enables an increased responsiveness from the engine and the gearbox. The steering is firmer.

"Comfort" mode

Using standard vehicle settings, this mode gives you the best compromise between comfort and dynamism.

"All-Terrain" mode

(depending on the vehicle)

This mode enables optimal usage on soft ground (mud, sand, dead leaves, etc.).

"SNOW" mode

(depending on the vehicle)

This mode allows you to optimise your vehicle's electronic stability control on slippery roads (snow, ice, etc.).

Use this mode on paved and slippery roads.

Note: the use of "SNOW" mode is not suitable in certain driving situations (on soft ground, deep snow, mud, sand, etc.).



In "All-Terrain" and "SNOW" mode, certain driving assistance functions (adaptive cruise control, Stop and Go, Active driver assist, etc.) are not available or are automatically deactivated when switching to one of these two modes.

AIR VENTS, HEATING AND AIR CONDITIONING

Air vents, air outlets

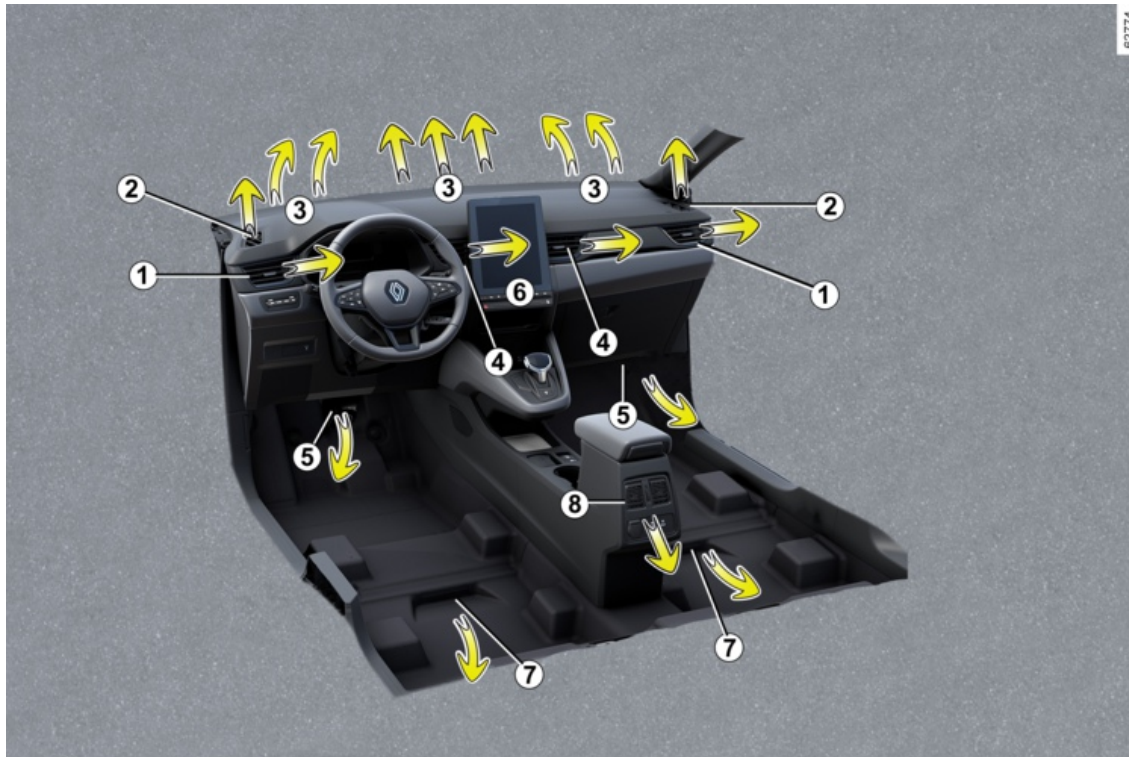

AIR VENTS, HEATING AND AIR CONDITIONING

1. Side air vents
2. Side window demister outlet
3. Windscreen demister outlet
4. Centre air vents
5. Footwell heater outlets for front passengers
6. Control panel
7. Footwell heater outlets for rear passengers
8. Rear passenger central air vents.

Central 4, side 1 and rear 8 air vents

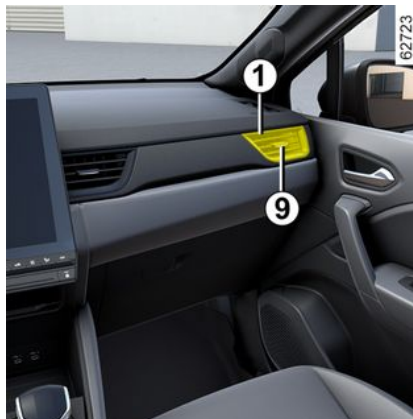
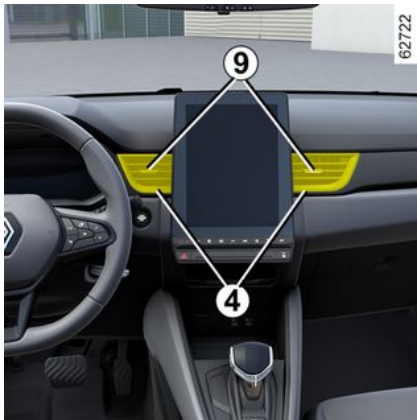

Air flow

To close: move the tab **9** towards the outside of the vehicle, beyond the point of resistance.

To open: move the tab **9** towards the inside of the vehicle.

Direction

Move the cursor **9** to the desired position.



Do not attach any objects to the air vents (e.g. telephone mounting).

Risk of damage.

Rear seats



(depending on the vehicle)

Passenger footwell heater outlets **7**.



Do not add anything to the vehicle's ventilation circuit (for example, to remove bad odours).

There is a risk of damage or of fire.

AIR VENTS, HEATING AND AIR CONDITIONING

Automatic climate control

The controls

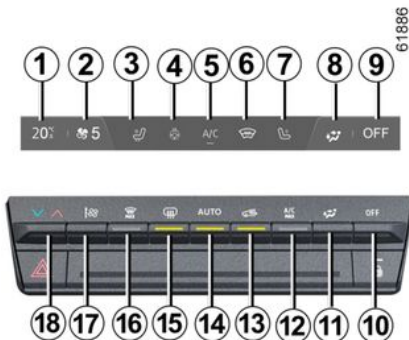

1. Heating temperature indicator.
2. Ventilation speed indicator.
3. Driver's heated seat activation control.
4. Heated steering wheel activation control.
5. Air-conditioning activation control.
6. Heated windscreen activation control.
7. Passenger's heated seat activation control.
8. Passenger compartment air distribution indicator.

9. System OFF stop indicator light.
10. System OFF stop control.
11. Passenger compartment air distribution adjustment.
12. Activation control for the "A/C MAX" function.
13. Air recirculation.
14. Air-conditioning activation control in AUTO mode.
15. De-icing/demisting of the rear screen and, depending on the vehicle, the rear view mirrors.
16. "Clear View" function.
17. Adjusting the ventilation speed and stopping the system.
18. Adjusting the air temperature.

Operation

Activating the system

When the vehicle is started, the system returns to the last programme used.

The system is also functional when parked.

Press the control **14** to activate the system or set the control **17** to the desired ventilation speed.

Stopping the system

Press control **17** "OFF".

Switching the air conditioning on or off

In automatic mode, the system manages activation of the air conditioning. You will still be able to activate or deactivate the system by pressing the control **5**.

Automatic mode

The automatic climate control system guarantees comfort in the passenger compartment and good visibility (except in the event of extreme conditions), while optimising fuel consumption.

The system controls the ventilation speed, air distribution, air recirculation, and starting and stopping the air conditioning and air temperature.

This mode consists of a choice of three programmes:

AUTO: optimises the selected comfort level according to exterior conditions. Press the button **14**.

SOFT: enables the desired temperature level to be obtained more smoothly and silently. Press button **14** then press downwards again to activate SOFT mode.

AIR VENTS, HEATING AND AIR CONDITIONING

FAST: increases the air flow in the passenger compartment. This mode is recommended in particular to optimise comfort in the rear seats. Press button **14** then press upwards again to activate FAST mode.

When the air conditioning starts in automatic mode, the system returns to the last programme used.



Any action on a button other than the AUTO button deactivates automatic mode.

Adjusting the distribution of air in the passenger compartment

Press **11** one or more times to select the air distribution. The air distribution selected **8** is displayed on the multimedia screen. The positions are in the following order:



All the air is then directed to the windscreen and front side window demisting vents.



The air flow is distributed between front side window demisting vents, the windscreen demisting vents and the footwells.



The air flow is distributed between the front side window demisting vents, the windscreen demisting vents, the dashboard air vents and the footwells.



The air flow is mainly directed to the dashboard air vents.



The air flow is directed towards the dashboard vents and towards the footwells.



The air flow is directed mainly towards the footwells.

Adjusting the air temperature

Press or raise control **18** to adjust the temperature displayed on the indicator light **1**.

Adjusting the ventilation fan speed

In automatic mode, the system uses the most suitable amount of air to reach and maintain the desired comfort level.

You will still be able to adjust the ventilation speed by pressing the control **17** to increase or reduce the ventilation speed.

"Clear View" function

Press the button **16** and the built-in warning light comes on.

This function quickly de-mists the windscreen, rear screen, front side windows and door mirrors (depending on the vehicle). It automatically activates the air conditioning and rear screen de-icing functions.

To exit this function, press button **14** or **16**.

Rear screen de-icing and demisting

Press the button **15** and the built-in warning light comes on. This function enables rapid demisting or de-icing of the rear screen and de-icing of the rear view mirrors (on equipped vehicles).

To exit this function, press button **15** again. Demisting automatically stops.

"A/C MAX" function

The "A/C MAX" function enables the user to feel the maximum power of their air conditioning system without any constraint or compromise related to the acoustics and the feeling of the air being too cold on the hands and face.

This function involves automatic modifications:

AIR VENTS, HEATING AND AIR CONDITIONING

- temperature programmed to fully cold;
- distribution of air to the occupants;
- air flow at its maximum power;
- activation of the air conditioning;
- air recirculation.

Press the button **12** to activate the function. Deactivate ECO mode for best performance.

Air recirculation (isolation of the passenger compartment)

This function is managed automatically, but you can also activate it manually. In this case the operation is confirmed by a warning light built into the button **13**.



Demisting/de-icing will still take priority over the air recirculation.

Manual use

Press the button **13** and the built-in warning light comes on.

Prolonged use of this position may lead to odours, caused by non-renewal of air, and the formation of condensation on the windows.

We therefore advise you to return to automatic mode as soon as air recircu-

lation is no longer needed, by pressing button **13**.

ECO mode



From the MULTI-SENSE menu, accessible from the multimedia screen **20** or by pressing the switch **19**, you can activate ECO mode, which affects the heating level and reduces the vehicle's fuel consumption.

An ECO warning light located under the temperature display on the multimedia screen **20** informs you that ECO mode is activated.

AIR VENTS, HEATING AND AIR CONDITIONING

"Favourites" function



Depending on the vehicle, by pressing the steering wheel control **21** you can activate the following functions according to the stored user settings that you have previously defined:

- heated steering wheel;
- heated seats;
- heated rear screen;
- heated rear view mirrors.

For more information on programming this function, please refer to the multimedia instructions.

Air conditioning: information and advice on use

Information and advice on use

Advice on use

In some situations (air conditioning off, air recirculation activated, ventilation speed at zero or low etc.), you may notice that condensation starts to form on the windows and windscreen.

If there is condensation, use the **"Clear View"** function to remove it, then use the air conditioning in automatic mode to stop it forming again.



Do not add anything to the vehicle's ventilation circuit (for example, to remove bad odours).

There is a risk of damage or of fire.

Fuel consumption

You will normally notice an increase in fuel consumption (especially when driving in town) when the air conditioning is operating.

For vehicles fitted with air conditioning with no automatic mode, switch off the system when it is not required.

Advice for reducing consumption and helping to preserve the environment

Drive with the air vents open and the windows closed. If the vehicle has been parked in the sun, open the doors for a few moments to let the hot air escape before starting the engine.

Maintenance

Refer to the maintenance document for your vehicle for the inspection frequency.



Use the air conditioning system regularly, even in cold weather, running it at least once a month for approximately 5 minutes.

Operating faults

As a general rule, contact your approved dealer in the event of an operating fault.

– **Reduction in de-icing, demisting or air conditioning performance.**

This may be caused by the cabin filter cartridge becoming clogged.

– **No cold air is being produced.**

AIR VENTS, HEATING AND AIR CONDITIONING

Check that the controls are set correctly and that the fuses are sound. Otherwise, switch off the system.

Special cases of hybrid versions

The vehicle's air conditioning system is used to cool the traction battery.

A prolonged drop in air conditioning efficiency may lead to premature deterioration of the traction battery.

Presence of water under the vehicle

After prolonged use of the air conditioning system, it is normal for water to be present under the vehicle. This is caused by condensation.



Do not open the refrigerant circuit. The fluid may damage eyes or skin.

Refrigerant fluid



The refrigerant fluid circuit (of which some components are hermetically sealed) may contain fluorinated greenhouse gases.

Depending on the vehicle, you will find the following information on label **A** affixed inside the engine compartment.

The presence and location of the information on label **A** depends on the vehicle.



Type of refrigerant fluid



Type of oil in the air conditioning circuit

59952



Inflammable product



Consult the vehicle user manual



Maintenance

x.xxx kg	(1) Quantity of refrigerant fluid present in the vehicle.
GWP xxxxx	(2) Global Warming Potential (CO2 equivalent).
CO2 eq x.xx t	(3) Quantity in weight and in CO2 equivalent.

Additional information

Depending on label and depending on the type of refrigerant:

Refrigerant fluid R-134yf

- (1) 0.420 kg (0.93 lbs) or, on E-Tech Full Hybrid versions, 0.520 kg (1.1 lbs)
- (2) GPWP 4
- (3) 0.002t

AIR VENTS, HEATING AND AIR CONDITIONING



Do not open the refrigerant circuit. The fluid may damage eyes or skin.



Before carrying out any action in the engine compartment, you must switch off the ignition

→ 140.

4

MULTIMEDIA EQUIPMENT

Multimedia settings



The location and operation of equipment may vary according to the vehicle.

1. Multimedia screen;
2. Multimedia sockets;
3. Steering column controls;
4. Steering column controls;
5. USB-C multimedia ports for the rear passengers.



Please refer to the multimedia instructions for further information.

"USB-C" multimedia socket 2 and 5

The USB-C multimedia sockets 2 and 5 can be used to charge accessories with a maximum power of 15 Watts (5 Volts) per socket.

Note: the USB-C 2 multimedia ports also allow for data transfer.



Connect accessories with a maximum power of 12 watts only.
Fire hazard.

Steering wheel controls 4



On those vehicles equipped, you can use the hands-free telephone control 6 and voice recognition control 7.

4

MULTIMEDIA EQUIPMENT

Microphone 8



Wireless charger 9

(depending on the vehicle)

→ 301



Using the telephone

We remind you of the need to conform to the legislation in force concerning the use of such equipment.

PASSENGER COMPARTMENT EQUIPMENT

Electric windows

These systems operate with the ignition on or off, until one of the front doors is opened (limited to about 3 minutes).



Driver's responsibility

Never leave your vehicle with the card inside, with a child, a dependent

adult or a pet, even for a short while.

They may pose a risk to themselves or to others by starting the engine or activating equipment (such as the gear lever or electric windows).

If any part of the body becomes trapped, reverse the direction of the window immediately by pressing the relevant switch.

Risk of serious injury.

One-touch electric windows



Briefly press or pull a window switch as far as it will go: the window will be fully raised or lowered. Pressing the switch again stops the window moving.

Note: the rear windows do not open fully.

From the driver's seat, use switch:

1. for the driver's side;
2. for the front passenger's side;
- 3 and 5 for the rear passengers.

From the passenger seats, press the switch 6.



Note: if the window detects resistance when almost fully closed (e.g. a tree branch), it stops and then lowers again by a few centimetres.



Avoid resting any objects against a half-open window: there is a risk that the electric window could be damaged.

PASSENGER COMPARTMENT EQUIPMENT



Passenger safety

The driver can prevent the front and rear passenger electric windows from operating (and the driver's window) by pressing switch **4**. A confirmation message is displayed on the instrument panel.

Impossible to operate the one-touch electric window

The one-touch electric window is equipped with heat protection: if you press the switch for the window more than 16 consecutive times it goes into protection mode (locking the window). You can:

- use the electric window switch briefly and with intervals of approximately 30 seconds;
- with the engine running, the window will be unlocked after approximately 20 minutes of inaction on the electric window switch.

Remote control window closing

When the doors are locked from the outside, if you **press for more than two seconds on the locking button for the driver's door in hands-free**

mode, on the card, all of the windows equipped with a one-touch electric window close automatically.

It is recommended that the user only operates the system when the vehicle can be seen clearly and no one is inside.



When closing the windows, ensure that no part of the body (arm, hand, etc.) is protruding from the vehicle.

Risk of serious injury.

Operating faults

In case of a fault when closing a window, the system reverts to normal mode: pull the switch concerned up as often as necessary to fully close the window (the window will close gradually), hold the switch (still on the closure side) for one second then lower and raise the window fully to reinitialise the system.

If necessary, contact an approved Dealer.

Opaque panoramic roof

The panoramic roof made of opaque glass is divided into two sections (front and rear).

It can become totally opaque or completely transparent. You can also make only one area opaque (front or rear).

Each transition or transition request is accompanied by an animation representing the roof.

Operation



To make **the entire roof** opaque or transparent, press and hold switch **1**.

To change **one of the sections (front or rear)** to opaque or transparent

PASSENGER COMPARTMENT EQUIPMENT

mode, press briefly on switch **1** as many as times as required.

Note: before pressing switch **1** again, you must wait for the previously selected action to be completed.

Depending on the vehicle, it is also possible to operate the vehicle by voice command. Please refer to the multimedia instructions for more information.



The roof becomes completely opaque several minutes after the engine has stopped, or when the doors are locked.



When the driver's door is opened, the roof resumes the status that was selected the last time the engine was stopped or the doors were locked.

Limits of operation

In very cold weather conditions, the panoramic roof may have limited operation (reduced movement) or may not work at all.

Interior lighting

Courtesy and reading lights

Reading lights *A*, *B* or *C*

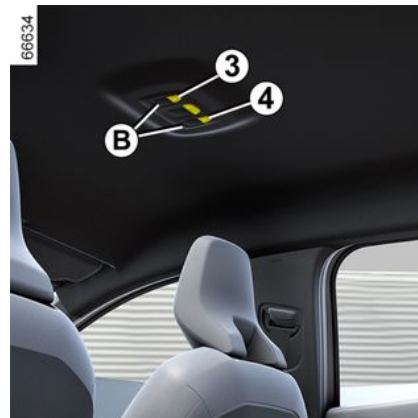
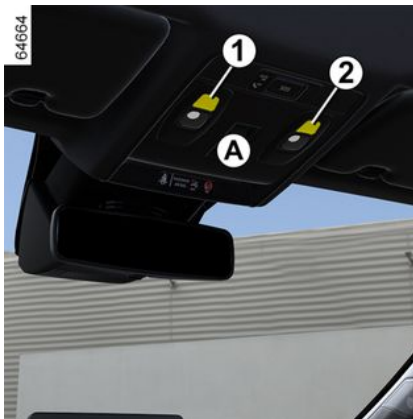

To enable permanent lighting, press:

- switch **1** for the driver;
- switch **2** for the front passenger;

PASSENGER COMPARTMENT EQUIPMENT

– switch **3**, **4** or, depending on the vehicle, switch **5** for the rear passengers.
To activate permanent lighting, press switch **2** for the driver or switch **3** for the front passenger.

Note: on vehicles fitted with a multimedia screen, you can use the multimedia screen to deactivate/activate the reading lights which switch on when the doors or luggage compartment are opened → 112.

Courtesy light *D*



Press the switch **6** to enable:

- permanent lighting;
- lighting controlled by the unlocking of the vehicle or by opening one of the doors. This switches off after a time

delay, once the relevant doors have been closed correctly;
– lighting switches off immediately.

Glove box light



The light **4** comes on when the cover is opened.

Luggage compartment light



The light **5** comes on when the luggage compartment is opened.



Unlocking and opening the doors or tailgate switches on the timed courtesy lights and lights.

PASSENGER COMPARTMENT EQUIPMENT

Sun visor, mirror

Front sun visor



Lower the sun visor **1**.

Courtesy mirrors

(depending on the vehicle)



Lift the cover **2**. The lighting **3** is automatic.



When driving, ensure the courtesy mirror cover is closed.

Risk of injury.

Accessories socket

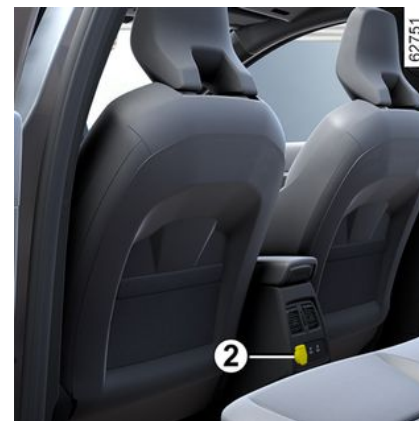

You can use sockets **1** and **2**.

PASSENGER COMPARTMENT EQUIPMENT



Connect accessories with a maximum power of 120 watts (12 V) only.

When several accessory sockets are used at the same time, the total power of the connected accessories must not exceed 180 watts.

Fire hazard.

4

PASSENGER COMPARTMENT STORAGE, FITTINGS

Storage compartments of the front doors 1

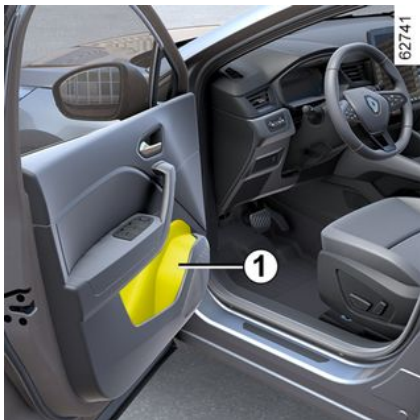

They can hold a 1.5-litre bottle.



Nothing should be placed on the floor (area in front of the driver) as these objects may slide under the pedals during sudden braking manoeuvres, thus obstructing their use.

Sun blind storage compartment 2



This can be used for storing motorway tickets, cards, etc.

Centre console storage compartment 3/induction charging zone 4



For more information on the induction charging zone, please refer to the multimedia instructions.



Ensure that no hard, heavy or pointed objects are placed in the "open" storage compartments in such a way that they may be projected onto passengers during sudden turning, braking or in the event of an accident.

PASSENGER COMPARTMENT STORAGE, FITTINGS

Centre console storage compartments 5 and 6



Ensure that no hard, heavy or pointed objects are placed in the "open" storage compartments in such a way that they may be projected onto passengers during sudden turning, braking or in the event of an accident.

Passenger storage compartment



Pull handle 7 to open it.

The storage compartment can hold A4-sized documents, a bottle etc.

Centre armrest storage compartment 10

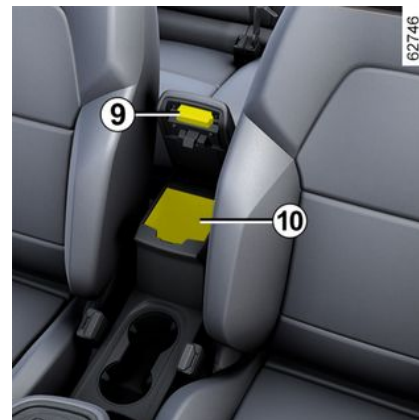
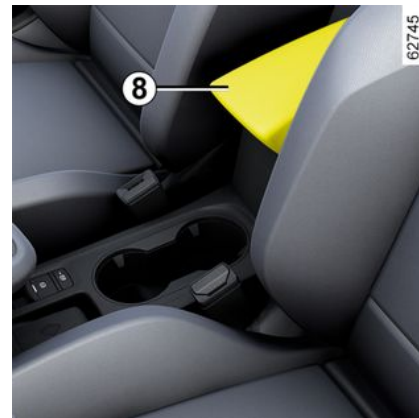

PASSENGER COMPARTMENT STORAGE, FITTINGS

Lift the cover **8** of the sliding armrest by pressing button **9**.

Cup holders **11**

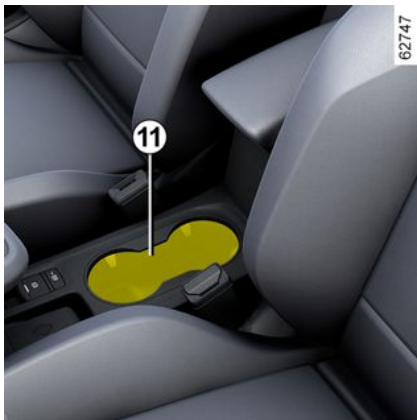

Depending on the vehicle, the cup holder may be equipped with retaining hooks to keep the cup in place.

This can be used to store a mobile ashtray, drink cans, etc.



When turning corners, accelerating or braking, ensure that the receptacle being held by the cup holder is not dislodged. **There is a risk of injury if hot liquid escapes.**

Storage compartments of the rear doors **12**



They can hold a 0.5-litre bottle.

Rear seat storage pockets **13**



Ensure that no hard, heavy or pointed objects are placed in the "open" storage compartments in such a way that they may be projected onto passengers during sudden turning, braking or in the event of an accident.

TRANSPORTING OBJECTS

Luggage compartment storage

Rear parcel shelf

Removal



- Unhook the two cords **1** from the luggage compartment;
- lift the shelf **2** to unclip it (movement **A**);
- pull the shelf towards you.

To refit, proceed in the reverse order to removal.



Do not place any heavy or hard object on the parcel shelf. These may pose a risk to the vehicle occupants if the driver has to brake suddenly or if the vehicle is involved in an accident.

Mobile floor

Flat position



Enables you to flatten the floor by folding down the back of the rear bench seat and to compartmentalise the boot into two distinct spaces.

The mobile floor **1** is positioned on the runner **2**.



Maximum weight for the mobile floor: 100 kg evenly distributed.

TRANSPORTING OBJECTS

Intermediate position



In the blocked position, it allows you to access the tools stored under the boot carpet.

- Remove the mobile floor **1**;
- place it in the luggage compartment using the runners provided **2**.

Storage position

(depending on the vehicle)

This allows for more space to store things in the boot.

- Remove the mobile floor **1**;
- move the rear bench seat forwards using the lever located at the rear seats → **52**;

- place the mobile floor **1** in the luggage compartment, underneath the runner **2**.

Transporting objects in the luggage compartment

Always position the objects transported so that the largest surface is against:



- the back of the rear bench seat, for normal loading (example **A**);

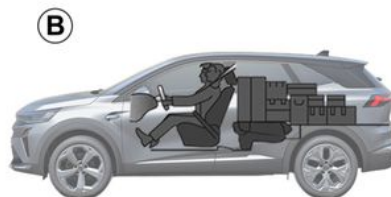

- the front seatbacks with the rear seatbacks folded down, as is the case for maximum loads (example **B**).

Ensure that the objects being transported are evenly distributed throughout the loading area.

If you have to place objects on the folded seat back, it is vital that you remove the headrests before folding the seat back so that it can be folded as flat as possible against the seat.

Note: in the absence of an emergency spare wheel or tyre inflation kit, do not load the bottom of the luggage compartment.

TRANSPORTING OBJECTS



Always position the heaviest items directly on the floor.

If the vehicle is equipped, use the lashing points **1** located on the luggage compartment floor.

The luggage should be loaded in such a way that no items will be thrown forward and strike the occupants if the driver has to brake suddenly.

Fasten the rear seat belts, even if the seats are not occupied.

Towbar



Permissible nose weight, maximum permissible towing weight while braked and unbraked: → 360. Choice and fitting of towing equipment

Towbar (cross member and hitch) not originally fitted to the vehicle: the entire towbar and mountings must not exceed 28 kg.

Any towing device must not obstruct any lighting component or the number plate when not in use. In all cases, you must comply with the regulations of the particular country you are in.

For fitting and conditions of use, refer to the equipment's fitting instructions.

Please keep these instructions with the rest of the vehicle documentation.

63561

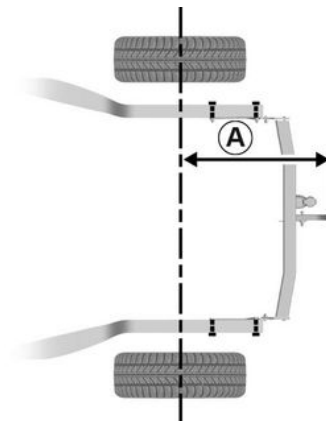

Maximum dimension **A**: 1,016 mm.

63562

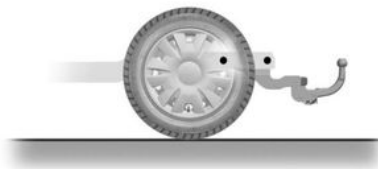

TRANSPORTING OBJECTS

Roof bars

Accessing the mounting points



Open the doors to access the mounting points **1**.



For information on the range of equipment adapted to your vehicle, we advise you to consult an approved dealer.

Refer to the fitting instructions for information on how to fit roof bars and conditions of use.

Please keep these instructions with the rest of the vehicle documentation.

Maximum permissible load on roof rack → 360.



If original roof bars, approved by our Technical Department, are supplied with screws, only use these screws for attaching the roof bars to the vehicle.

User precautions

Handling the tailgate

Before operating the luggage compartment door, check the objects and/or accessories (bicycle rack, roof box, etc.) fitted on the roof bars: these must be correctly positioned and secured,

and must not prevent the luggage compartment door from operating correctly.

Spoiler A



It is prohibited to attach any carrying equipment (bike rack, luggage box etc.) resting against the spoiler or tailgate. To install a carrying device on your vehicle, contact an approved dealer.

ACCESSING THE ENGINE, LEVELS

Bonnet



To open, pull the handle **1** located on the left-hand side of the dashboard.



Before carrying out any action in the engine compartment, you must switch off the ignition

➔ 140.



Avoid placing any pressure on the engine bonnet: risk of the bonnet closing by accident.



Any intervention or modification on the vehicle's "230 V" electrical system (components, cables, connectors, traction battery) is strictly prohibited.

The risk of serious burns or electric shocks can lead to death.

The engine cooling fan may also

start at any moment. The  label in the engine compartment reminds you of this.

Risk of injury.

Unlocking the bonnet catch



To unlock, push the tab **2** while opening the bonnet.



Please note when working close to the engine that it may be hot. The engine cooling fan may also start at any moment. The



label in the engine compartment reminds you of this.
Risk of injury.

ACCESSING THE ENGINE, LEVELS

Opening the bonnet

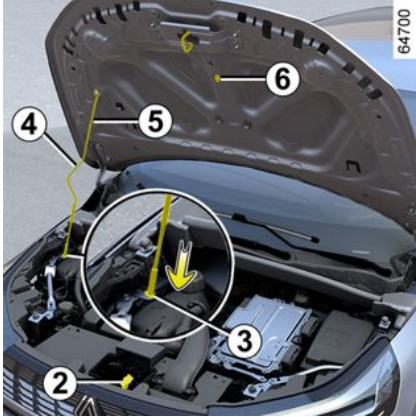

Lift the bonnet, disengage the stay **5** from its mounting **6** using the handle **4** and, for your own safety, you **must** fix the stay into its retainer **3**.



When working in the engine compartment, ensure that the windscreen wiper stalk is in the park

position.

Risk of injury.

Closing the bonnet

Before closing the bonnet, make sure that nothing has been left in the engine compartment.

To close the bonnet, refit the stay **5** into its holder **6**. Hold the middle of the bonnet and guide it down to one foot (30 cm) above the closed position, then release. It will latch automatically under its own weight.



Ensure that the bonnet is properly locked.

Check that nothing is preventing the catch from locking (gravel, cloth, etc.).



After any procedure in the engine compartment, make sure that you do not forget anything

(cloth, tools, etc.).

Otherwise, this may lead to engine damage or cause a fire.



In the event of even a slight impact involving the radiator grille or bonnet, have the bonnet lock checked by an approved dealer as soon as possible.

Engine oil

General information

It is normal for an engine to use oil for lubrication and cooling of moving parts and it is normal to top up the level between oil changes.

However, contact your approved Dealer if more than 0.11 gal (0.5 litre) is being consumed every 600 miles (1,000 km) after the running in period.

Oil change frequency: check the oil level from time to time and certainly before any long journey to avoid the risk of damaging your engine.

Reading the oil level

The oil level should be read with the vehicle on level ground, after the engine has been switched off for some time.

The dipstick must be used to read the exact oil level and make sure

ACCESSING THE ENGINE, LEVELS

that the maximum level has not been exceeded (risk of engine damage).

Depending on the vehicle, the instrument panel display only alerts the driver when the oil level is at its minimum.

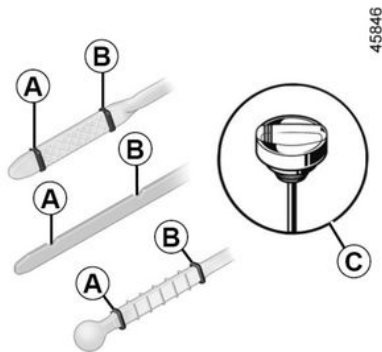

- Remove the dipstick and wipe with a clean, lint-free cloth;
- push the dipstick in as far as it will go (for vehicles equipped with a "cap-dipstick" **C**, screw the cap in as far as it will go);
- remove the dipstick again;
- read the level: it should never fall below the "mini" level **A** nor rise above the "maxi" level **B**.

Once the operation has been completed, ensure that the dipstick is pushed in as far as it will go or that the "cap-type dipstick" is completely screwed in.



Adding engine oil

Use a funnel or protect the filling neck area to avoid engine oil escaping onto a hot part of the engine compartment or a sensitive part (e.g. electrical components).

Fire hazard.



Exceeding the maximum engine oil level

Under no circumstances should the maximum filling level **B** be exceeded: this could damage the engine and the emission control system. If the level exceeds the maximum level, **do not start your vehicle** and contact an authorised dealer.



Before carrying out any action in the engine compartment, you must switch off the ignition

→ 140.

Topping up, filling, draining

Topping up/filling

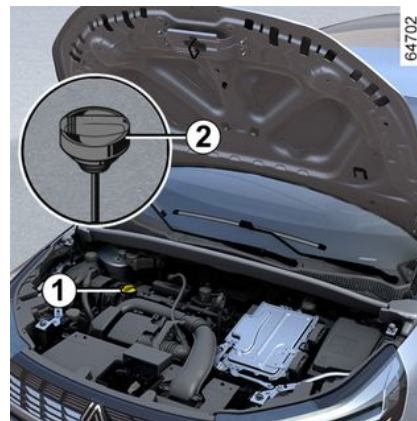

The vehicle must be parked on level ground and the engine should be stopped and cold (for instance, before the engine is started up for the first time in the day).

ACCESSING THE ENGINE, LEVELS



Before carrying out any action in the engine compartment, you must switch off the ignition

→ 140.



Do not exceed the "maxi" level and remember to refit the cap **1** and the dipstick

2.

- Loosen the cap **1**;
- top up the level (as a guide, the capacity between the "mini" and "maxi" level of the dipstick **2** is between 0.20 gal (0.9 l) and 0.44 gal (2 l), depending on the engine);
- wait for approximately 20 minutes to allow the oil to flow;
- check the level using the dipstick **2** (as described previously).

Once the operation has been completed, ensure that the dipstick is pushed in as far as it will go or that the cap-type dipstick is completely screwed in.



Adding engine oil

Use a funnel or protect the filling neck area to avoid engine oil escaping on to a hot part of the engine compartment or a sensitive part (e.g. electrical components).

Fire hazard.

Oil change

Service interval: refer to the maintenance document for your vehicle.

Oil change capacity

Please refer to the maintenance document for your vehicle, or contact an authorised dealer. Always check the engine oil level using the dipstick, as explained previously (it should never fall below the minimum level, or be over the maximum level on the dipstick).

Engine oil grade

Refer to the maintenance document for your vehicle.



Exceeding the maximum engine oil level

Under no circumstances should the maximum filling level be exceeded: this could damage the engine and the emission control system.

If the oil level exceeds the maximum level, **do not start your vehicle** and contact an approved dealer.



Engine oil change: if you are changing the oil when the engine is hot, be careful not to scald yourself as the oil drains.



If there is an abnormal or repeated drop in the fluid level, consult an approved dealer.

ACCESSING THE ENGINE, LEVELS



When working in the engine compartment, ensure that the windscreen wiper stalk is in the park position.
Risk of injury.



Filling and/or checking the oil level: when topping up or checking the oil level, ensure that no oil leaks onto the engine components.
Do not forget to properly close the cap and refit the dipstick to prevent any oil spatter on hot engine components.
Fire hazard.



Please note when working close to the engine that it may be hot. The engine cooling fan may also start at any moment. The  label in the engine compartment reminds you of this.
Risk of injury.



Never run the engine in an enclosed space as exhaust gases are poisonous.

Coolant level

Combustion engine coolant



With the ignition off and the vehicle on level ground, the level **when cold** must be between the "MINI" and "MAXI" markers indicated on the coolant reservoir **1**.

Top this level up **when cold** before it reaches the "MINI" marker.

Frequency of checking coolant level

Check the coolant level regularly (very severe damage is likely to be caused to the combustion engine if it runs out of coolant).

ACCESSING THE ENGINE, LEVELS

If the level needs to be topped up, only use products approved by our Technical Department which ensure:

- antifreeze protection;
- anti-corrosion protection of the cooling system.



Before carrying out any action in the engine compartment, you must switch off the ignition

→ 140.

Replacement intervals

Refer to the maintenance document for your vehicle.



If there is an abnormal or repeated drop in the fluid level, consult an approved dealer.



When working in the engine compartment, ensure that the windscreen wiper stalk is in the park position.

Risk of injury.



No operations should be carried out on the cooling circuit when the combustion engine is hot.

Risk of burns.

Electric traction system coolant



This system is different to that of the combustion engine. It is used for cooling the electric motor.

Reading the level

With the ignition off and the vehicle parked on level ground, unscrew the coolant reservoir cap **2**.

When **cold**, the level should be located between the "MIN" **3** and "MAX" **4** marks shown on the inside of the funnel.

Frequency of checking coolant level

Check the coolant level regularly (very severe damage is likely to be caused to the electrical circuit if it runs out of coolant).

If a top-up is required, you must contact an approved dealer to perform the top-up.



Before carrying out any action in the engine compartment, you must switch off the ignition

→ 140.

Replacement intervals

Refer to the maintenance document for your vehicle.

ACCESSING THE ENGINE, LEVELS



If there is an abnormal or repeated drop in the fluid level, consult an approved dealer.



When working in the engine compartment, ensure that the windscreen wiper stalk is in the park position.

Risk of injury.



No operations should be carried out on the cooling circuit when the combustion engine is hot.

Risk of burns.

Levels, filters

Brake fluid level



This should be checked frequently, and immediately if you notice even the slightest loss in braking efficiency.

The level should be read with the engine switched off and on level ground.

Level 5

It is normal for the level to fall as the trims become worn, but it must never fall below the "MINI" warning line.

If you wish to check the disc and drum wear yourself, you should obtain the document explaining the checking procedure from the manufacturer's network or website.

Topping up

After any operation on the hydraulic circuit, a specialist must replace the fluid.

Only use fluids approved by our Technical Department (and taken from a sealed container).

Replacement intervals

Refer to the maintenance document for your vehicle.



If there is an abnormal or repeated drop in the fluid level, consult an approved dealer.



Please note when working close to the engine that it may be hot. The engine cooling fan may also start at any moment. The



label in the engine compartment reminds you of this.

Risk of injury.

ACCESSING THE ENGINE, LEVELS

Windscreen washer reservoir



Topping up

With the engine off, open the cap **6**. Fill until you can see the fluid, then replace the cap.

Note: check the reservoir level regularly and top up the fluid before going on a trip.

Fluid

Windscreen washer fluid. In winter, use anti-freeze product. Use products recommended by an authorised dealer.

Note: do not use hard water (risk of damage to the priming pump, limescale building up on the pump and the jets).

Jets

To adjust the height of the windscreen washer jets, please consult an authorised dealer.



Before carrying out any action in the engine compartment, you must switch off the ignition

→ 140.

Filters

The filter elements (air filter, cabin filter etc.) should be replaced during the maintenance operations carried out on your vehicle.

Replacement intervals for filter components: refer to the maintenance document for your vehicle.



When working in the engine compartment, ensure that the windscreen wiper stalk is in the park

position.

Risk of injury.



Please note when working close to the engine that it may be hot. The engine cooling fan may also start at any moment. The



label in the engine compartment reminds you of this.

Risk of injury.

BATTERY

Secondary 12 V battery

In the luggage compartment



The secondary "12 V" battery is located in the luggage compartment: it supplies the power required to unlock/lock the vehicle and to operate the equipment.

You should not open it or add any fluid.

The secondary "12 V" battery **1** charge level may diminish, especially if you use your vehicle:

- when the outside temperature drops;
- after extended use of power-consuming functions while the ignition is switched off;

– after a prolonged period of parking.



For your safety and to ensure the proper operation of the vehicle's electrical equipment (lights, windscreen wipers, braking assistance, etc.), any work on the secondary "12 V" battery (removal, disconnection, etc.) **must** be carried out by a specialist professional.

Risk of serious burns or electric shocks.

You **must** respect the replacement intervals (without exceeding them) as stated in the maintenance document.

The battery is a specific type.

Please ensure it is replaced with the same type.

Call an approved dealer.



Observe the indications on the battery:

2. naked flames and smoking are forbidden;

3. eye protection must be used;

4. keep away from children;

5. explosive materials;

6. refer to the manual;

7. corrosive substances.



Do not disconnect the "12 V" secondary battery; this is prohibited.

Risk of serious burns or electric shocks.

CLEANING

Bodywork maintenance

A well-maintained vehicle will last longer.

It is therefore recommended to maintain the exterior of the vehicle regularly.

Your vehicle has been treated with very effective anti-corrosion products. It is nevertheless subject to various outside influences.

Corrosive agents in the atmosphere

- Atmospheric pollution (in built-up and industrial areas);
- saline atmospheres (near the sea, particularly in hot weather);
- seasonal and damp climatic conditions, (e.g.: road salt in winter, water from road cleaners, etc.).

Minor impacts

Abrasive action

Dust and sand in the air, mud, road grit thrown up by other vehicles, etc.

You should take a number of minor precautions in order to safeguard your vehicle against such risks.

You should do the following

Wash your car frequently, **with the engine off**, with cleaning products recommended by our Technical Department (never use abrasive products).

Rinse thoroughly beforehand using a jet washer:

- spots of tree resin and industrial pollution;
- mud in the wheel arches and underneath the body which forms damp patches;
- **bird droppings, which cause a chemical reaction with the paint that rapidly discolours paintwork and may even cause the paint to peel off.**

Wash the vehicle **immediately** to remove these marks as it is impossible to remove them by polishing;

- salt, particularly in the wheel arches and underneath the body after driving in areas where the roads have been gritted.

Withdraw the vegetable falls (resin, film etc.) from the vehicle regularly.

Observe the vehicle stopping distances when driving on gravelled surfaces to prevent paint damage.

Repair, or have repaired quickly, areas where the paint has been damaged, to prevent corrosion spreading.

Remember to visit the body shop periodically in order to maintain your anti-corrosion warranty. Refer to the maintenance document.

Observe local regulations about washing vehicles (e.g. do not wash your vehicle on a public highway).

When washing the vehicle with a high-pressure cleaning device, please take the following precautions:

- make sure that your vehicle's paintwork, the area or the component that you want to clean is compatible with this type of washing;
- the pressure delivered by the device must be less than 100 bar;
- when washing, position the spray nozzle at least 15 cm from the vehicle and check that the water flow rate is less than 3.30 gal (15 l)/min);
- do not persist in washing the same area, impacted points or the seals (risk of damage to the paint, seals becoming detached, etc.).

If mechanical components, hinges, etc. have been cleaned, they must be protected again by spraying with products approved by our Technical Department.



We have selected special products to care for your vehicle and you can obtain these from the manufacturer's accessory outlets.

CLEANING

Do not do the following

Wash the vehicle in bright sunlight or freezing temperatures.

Do not scrape off mud or dirt without pre-wetting.

Allow dirt to accumulate on the exterior.

Allow rust to form following minor impacts.

Using solvents not approved by our Technical Department to remove stains may damage the paintwork.

Do not drive in snow or muddy conditions without washing the vehicle, particularly under the wheel arches and body.



Degrease or clean using high-pressure cleaning equipment or by spraying products not approved by our Technical Department:

- mechanical components (e.g. engine compartment);
- wheels (e.g. braking system components such as brake callipers);
- the underbody;
- the parts with hinges (e.g. inside the doors);
- the painted plastic external fittings (e.g. bumpers).

Doing this could give rise to corrosion or operational faults.

Vehicles with a matte paint finish

This type of paint requires certain precautions.

You should do the following

Wash the vehicle by hand using plenty of water, using a soft cloth or a gentle sponge.

Do not do the following

Use wax-based products (polishing).

Rub too hard.

Wash the vehicle in a roller-type car wash.

Attach stickers to the paintwork (risk of leaving marks).



Wash the vehicle using a high-pressure cleaning device.

Using a roller type car wash

Return the wiper stalk to the Park position ➔ 131 .

Check the mounting of external accessories, additional lights and rear view mirrors, and ensure that the wiper

blades are secured with adhesive tape.

Remove the radio aerial mast if your vehicle is fitted with this equipment.

Check that the fuel filler flap is closed then lock the vehicle.

Remember to remove the tape and re-fit the antenna after washing.

Cleaning the headlights, sensors and cameras

Use a soft cloth or cotton wool.

If this does not clean them properly, moisten the cloth with soapy water, then wipe clean with a soft damp cloth or cotton wool.

Finally, carefully dry off with a soft dry cloth.

Do not use cleaning products containing alcohol or utensils (e.g. a scraper).

Cleaning stickers, decorative films, etc.

You should do the following

Use a soft cloth or cotton wool.

Moisten it slightly with soapy water then always wipe clean with a soft cloth or cotton wool.

Finally, carefully dry off with a soft dry cloth.

CLEANING

Do not do the following

Use alcohol-based cleaning products.

Use utensils (e.g. a scraper).

Rub too hard.



Wash the vehicle using a high-pressure cleaning device.

Interior trim maintenance

A well-maintained vehicle will last longer. It is therefore recommended to maintain the interior of the vehicle regularly.

A stain should always be dealt with swiftly.

Whatever the type of the stain, use **cold (or tepid) soapy water with natural soap**.

Detergents (washing-up liquid, powdered products, alcohol-based products) should not be used.

Use a soft cloth.

Rinse and wipe up excess water.

Multimedia screen

Maintenance of the screen may depend on the type of multimedia equipment. Please refer to the multimedia instructions for further information.

Glass instrument panel

(e.g. instrument panel, clock, exterior temperature display)

Use a soft cloth or cotton wool.

If this does not clean them properly, use a soft cloth (or cotton wool) slightly moistened with soapy water and then wipe clean with another soft damp cloth or cotton wool.

Finally, **carefully** dry off with a soft dry cloth.

Do not use products containing alcohol and/or spray fluids on the area.

Seat belts

These must be kept clean.

Use products selected by our Technical Department (Approved outlets) or warm, soapy water and a sponge and wipe with a dry cloth.

Detergents or dyes must not be used under any circumstances.

Textiles (seats, door trim, etc)

Vacuum-clean the textiles **regularly**.

Liquid stain

Use soapy water.

Dab lightly (never rub) with a soft cloth, rinse and remove the excess.

Solid or pasty stain

Carefully remove the excess solid or pasty material **immediately** using a spatula (working from the edges to the centre to avoid spreading the stain).

In the case of a liquid stain, clean as indicated.

Special instructions for sweets or chewing gum

Place an ice cube on the stain to solidify it then proceed as for a solid stain.



For further recommendations for maintaining the interior, and/or for any unsatisfactory results, please see an authorised dealer.

Removal/replacing removable equipment originally fitted in the vehicle

If you need to remove equipment in order to clean the passenger compartment (for example, mats), always ensure that they are correctly refitted and are the right way around (the driver's mat should be fitted on the driver's side, etc.) and fit them with the components supplied with the equipment (for example, the driver mat should always be fixed using the pre-fitted mounting components).

CLEANING

With the vehicle stationary, always ensure that nothing will impede driving (anything obstructing the pedals, heel wedged by the mat etc.).

Do not do the following

Position objects such as deodorants, scents etc. near air vents as this could damage your dashboard trim.



5

Use high-pressure cleaning equipment or sprays inside the passenger compartment:

without careful use, this equipment could impair the correct functioning of the electrical or electronic components in the vehicle, or have other detrimental effects.

TYRES

Tyres

Tyre and wheel safety

The tyres are the only contact between the vehicle and the road, so it is essential to keep them in good condition.

You must make sure that your tyres conform to local road traffic regulations.

Maintaining the tyres



The tyres must be in good condition and the treads must have sufficient depth: tyres approved by our Technical Department have wear warning strips **1** which are **indicators moulded into the tread at several points**.



Incidents which occur when driving, such as striking the kerb, may damage the tyres and wheel rims, and could also lead to misalignment of the front or rear axle geometry. In this case, have the condition of these checked by an approved dealer.

When the tyre tread has been worn to the level of the wear indicators **these become visible 2** : **it will then be necessary to replace your tyres as the tread depth will be 1.6 mm at most, resulting in poor road-holding on wet roads.**

An overloaded vehicle, long journeys by motorway, particularly in very hot weather, or continual driving on poorly surfaced minor roads will lead to more rapid tyre wear and affect safety.

Tyre pressures

Adhere to the tyre pressures (including the emergency spare wheel). The tyre pressures should be checked at least once a month and additionally before any long journey (refer to the label affixed to the edge of the driver's door).



Incorrect tyre pressures lead to abnormal tyre wear and unusually hot running. These are factors which may seriously affect safety and lead to:

- poor road holding;
- the risk of blow-outs or of throwing a tread.

The pressure depends on the load and the speed of use. Adjust the pressure according to the conditions of use (refer to the label affixed to the edge of the driver's door).

Pressures should be checked when the tyres are cold. Ignore higher pressures which may be reached in hot weather or after driving at high speed.

If tyre pressures cannot be checked when the tyres are **cold, assume an increase of 0.2 to 0.3 bar** (or 3 PSI).

Never deflate a hot tyre.

TYRES



Please be aware that a poorly tightened or missing valve cap can make the tyres less airtight and may lead to pressure loss. Always use valve caps identical to the originals and screw them down fully.

Vehicle fitted with a tyre pressure loss warning system

In the event of under-inflation (punctures, under-inflation etc.), the  warning light appears on the instrument panel → 163.

Emergency spare wheel

→ 328, → 330.

Changing wheels around

This practice is not recommended.

Fitting new tyres



For your safety and to comply with the law. When they need to be replaced, only tyres of the same make, size, type and profile should be used on a single axle.

They must either have a load capacity and speed rating at least equal to those of the original tyres or conform to those recommended by an authorised dealer.

Failure to heed these instructions could endanger your safety and affect your vehicle's roadworthiness.

Risk of loss of control of the vehicle.

Use in winter

Chains

For safety reasons, fitting snow chains to the rear axle is strictly forbidden.

Chains cannot be fitted to tyres which are larger than those originally fitted to the vehicle.

One-way tyres

An one-way tyre must only be fitted in one direction. You must observe this direction.

If an one-way tyre must be fitted in the opposite to its direction of rotation following a puncture, drive with caution, particularly on a wet road, because the tyre specifications will not be adapted.



Chains may only be fitted to tyres of the same size as those originally fitted to **your vehicle**.

"Snow" or "Winter" tyres

We would recommend that these be fitted to all **four wheels** to ensure that your vehicle retains maximum adhesion.

Caution: these tyres sometimes have a specific direction of rotation and a maximum speed index which may be lower than the maximum speed for your vehicle.

Studded tyres

This type of equipment may only be used for a limited period and as laid down by local legislation. It is necessary to observe the speed specified by current legislation.

TYRES

These tyres must, at a minimum, be fitted to the two front wheels.



18" wheels cannot be fitted with chains.

If you wish to fit snow chains, you must use

special equipment.

Consult an approved dealer.



In all cases, we would recommend that you contact an approved Dealer who will be able to advise you on the choice of equipment which is most suitable for your vehicle.

Tyre pressure

Label A

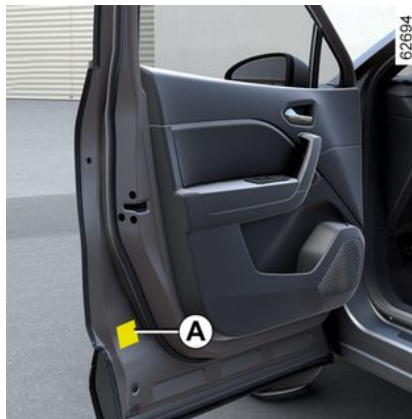

Open the door to read it.

Tyre pressures should be checked when the tyres are cold.

If tyre pressures cannot be checked when the tyres are **cold**, the **pressure values indicated must be increased by 0.2 to 0.3 bar (or 3 PSI). Never deflate a hot tyre.**

Tyre pressures must correspond to the current usage of the vehicle (empty, carrying a load, motorway driving, etc.). Respect the tyre pressures (including the emergency spare wheel). These must be checked at least once a month and before any long journey.

Depending on the vehicle, after each reinflation or readjustment of the tyre pressure, you should reset the tyre pressure reference value → 163.

Vehicle fitted with a tyre pressure loss warning system

In the event of under-inflation (punctures, under-inflation etc.), the  warning light appears on the instrument panel → 163.

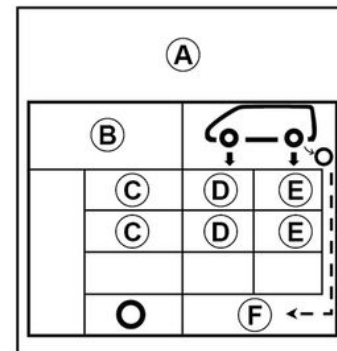

B. : dimension of the tyres fitted to the vehicle.

C. : intended driving speed.

D. : front tyre pressure.

E. : rear tyre pressure.

TYRES

F : tyre pressure for the emergency spare wheel.



Vehicles used fully laden (Maximum Permissible All-up Weight) and towing a trailer

The maximum speed must be limited to **62 mph (100 km/h)** and the tyre pressure increased by **0.2 bar → 360**.

Risk of tyre blowouts.

Tyre safety and chain fitting: for information on maintenance conditions and, depending on the vehicle version, the use of chains → **321**.



For your safety and to comply with the law. When they need to be replaced, only tyres of the same make, size, type and profile should be used on a single axle.

They must either have a load capacity and speed rating at least equal to those of the original tyres, or conform to those recommended by an approved dealer.

Failure to heed these instructions could endanger your safety and affect your vehicle's roadworthiness.

Risk of loss of control of the vehicle.

Tyre inflation kit



The kit repairs tyres when the tread **A** has been damaged by objects smaller than 4 mm.

It cannot repair all types of puncture, such as cuts larger than 4 mm, cuts in the tyre sidewall **B**, etc.

Ensure also that the wheel rim is in good condition.

Do not pull out the foreign body causing the puncture if it is still in the tyre.

TYRES



Do not attempt to use the inflation kit if the tyre has been damaged as a result of driving with a puncture.

You should therefore carefully check the condition of the tyre sidewalls before any operation. Driving with underinflated, flat or punctured tyres can be dangerous and may make the tyre impossible to repair.

This repair is temporary.

A tyre which has been punctured should always be inspected (and repaired, where possible) by a specialist as soon as possible. When taking a tyre which has been repaired using this kit to be replaced, you must inform the specialist.

When driving, vibration may be felt due to the presence of the repair product injected into the tyre.



The kit is only approved for inflating the tyres of the vehicle originally equipped with the kit.

It must never be used to inflate the tyres of another vehicle, or any other inflatable object (rubber ring, rubber boat, etc.).

Avoid spillage on skin when handling the repair product bottle. If droplets do leak out, rinse them off with plenty of water. Keep the repair kit away from children.

Do not dispose of the empty bottle in the countryside. Return it to your approved dealer or to a recycling organisation.

The bottle has a limited service life which is indicated on its label. Check the expiry date.

Contact an approved dealer to replace the inflation tube and repair product bottle.

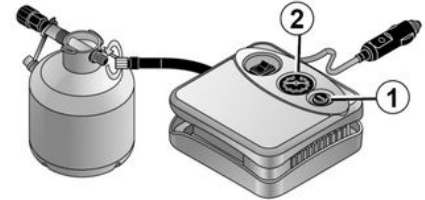

47426

6

Depending on the equipment, in the event of a puncture, use the kit located underneath the luggage compartment carpet.

Vehicle fitted with a tyre pressure loss warning system

In the event of under-inflation (punctures, under-inflation etc.), the  warning light appears on the instrument panel ➔ 163.

With the engine running and the parking brake applied:

- Disconnect any accessories from the vehicle's accessories sockets;
- **see the information on the inflation kit compressor** located in the ve-

TYRES

hicle luggage compartment and follow the instructions for use;

- inflate the tyre to the recommended pressure → **323**;
- after a maximum of **15** minutes, stop inflating and read the pressure (on the pressure gauge **2**).

Note: while the bottle is emptying (during approximately 30 seconds), the pressure gauge **2** will briefly indicate a pressure of up to 6 bar before the pressure drops;

- adjust the pressure: to increase it, continue inflation with the kit. To reduce it, press the button **1**.

If the recommended pressure of 1.8 bar cannot be achieved after 15 minutes, repair is impossible. Do not drive the vehicle. Consult an approved dealer.



Before using the kit, park the vehicle at a sufficient distance from traffic, switch on the hazard warning lights, apply the parking brake, ask all passengers to leave the vehicle and keep them away from traffic.



If the vehicle is parked on the hard shoulder, you must warn other road users of your vehicle's presence with a warning triangle or with other devices as per the legislation applying to the country you are in.

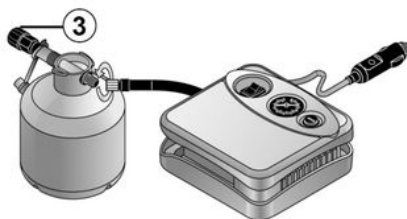

Once the tyre is correctly inflated, remove the kit: slowly unscrew the inflation adapter from the container **3** to prevent any product spatter, then store the container in plastic packaging to prevent the product from leaking.

- Affix the driving recommendation label (located under the container) to the dashboard where the driver can see it.
- Put the kit away.
- At the end of this initial inflation operation, air will still escape from the tyre. You must drive a short distance in order to seal the hole.
- Start immediately and drive at a speed between 12 and 37 mph (20 to 60 km/h) in order to distribute the product evenly in the tyre. After driving a distance of 2 miles (3 km), stop and check the pressure.
- If the pressure is higher than 1.3 bar but lower than the recommended pressure (refer to the label affixed to the edge of the driver's door), adjust it. Otherwise, contact an approved dealer: the tyre cannot be repaired.

Precautions when using the kit

The kit should not be operated for more than 15 consecutive minutes.

The container must be replaced after the first use even if liquid remains inside.

TYRES



Nothing should be placed around the driver's feet as during sudden braking such objects may slide under the pedals and obstruct their use.



Please be aware that a poorly tightened or missing valve cap can make the tyres less airtight and may lead to pressure loss. Always use valve caps identical to the originals and screw them down fully.



Following repair with the kit, do not travel further than 124 miles (200 km). In addition, reduce your speed and under no circumstances exceed 50 mph (80 km/h). The sticker, which you must affix in a prominent position on the dashboard, reminds you of this. Depending on the country or local legislation, a tyre repaired with the inflation kit will need to be replaced.

Tools



The tools included in the tool kit **A** may vary depending on the vehicle. After use, ensure the tools are correctly stored.



Lever 1

This can be used to tighten or loosen the towing eye 5.

Jack 2

Fold it correctly before refitting it in its housing (ensure that the wheelbrace is correctly positioned).

Hubcap tool 3

This tool is used to remove the wheel trims.

TYRES

Wheel bolt guide 4

To finish loosening or starting to tighten the wheel bolts.

Towing eye 5

→ 332

Wheelbrace 6

This can be used to lock or unlock the wheel bolts and the towing eye 5.



Do not leave the tools unsecured inside the vehicle as they may be projected during braking.

After use, check that all the tools are correctly clipped into the tool kit, then position it correctly in its housing to reduce any risk of injury.

If bolts are supplied with the emergency spare wheel, you must use these bolts only for the emergency spare wheel.



For safety reasons, the use of a jack not recommended by the manufacturer is strictly forbidden.

The jack is specific to the vehicle and used to change the wheels. Under no circumstances should it be used:

- on another vehicle;
- to carry out a repair;
- to access the underside of the vehicle.

Risk of injury.

Risk of damage to the vehicle.

Puncture, emergency spare wheel

In case of puncture



Depending on the vehicle, the following may be available:

- a tyre inflation kit **A** located in the tray under the luggage compartment carpet or in the rear left-hand door storage compartment → 324 (depending on the vehicle);
- an emergency spare wheel **B** or self-repairing tyres.

TYRES

Vehicle fitted with a tyre pressure loss warning system

In the event of under-inflation (punctures, under-inflation etc.), the  warning light appears on the instrument panel → 163.



If the spare wheel has been stored for several years, have it checked by your Dealer to ensure that it is safe to use.

Vehicle equipped with an emergency spare wheel that differs from the other four wheels:

- Never fit more than one emergency spare wheel to the same vehicle.
- Replace the emergency spare wheel as soon as possible with a wheel identical to the original one.
- When this is fitted to the vehicle, which must only be a temporary measure, the driving speed must not exceed the speed indicated on the label on the wheel.
- Fitting an emergency spare wheel may alter the way the vehicle usually runs. Avoid sudden acceleration or deceleration and reduce your speed when cornering.
- If you need to use snow chains, fit the emergency spare wheel to the rear axle and check the tyre pressure.



If the vehicle is parked on the hard shoulder, you must warn other road users of your vehicle's presence with a warning triangle or with other devices as per the legislation applying to the country you are in.

Emergency spare wheel

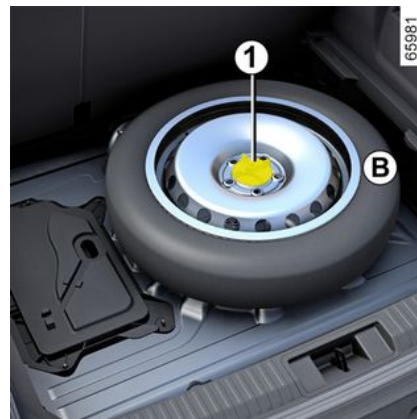

To get to it:

- open the luggage compartment door;
- raise the mobile floor → 304;

TYRES

With the wheel on the ground, tighten the bolts fully and have the tightness of the bolts checked and the emergency spare wheel pressure checked as soon as possible.



If you have a puncture, replace the wheel as soon as possible.

A tyre which has been punctured should always be inspected (and repaired, where possible) by a specialist.

Vehicle fitted with a tyre pressure loss warning system

In the event of under-inflation (punc-

ture, flat tyre, etc.), the  warning light appears on the instrument panel → 163.



Do not leave the tools unsecured inside the vehicle as they may be projected during braking.

After use, check that all the tools are correctly clipped into the tool kit, then position it correctly in its housing to reduce any risk of injury.

If bolts are supplied with the emergency spare wheel, you must use these bolts only for the emergency spare wheel.



For safety reasons, the use of a jack not recommended by the manufacturer is strictly forbidden.

The jack is specific to the vehicle and used to change the wheels. Under no circumstances should it be used:

- on another vehicle;
- to carry out a repair;
- to access the underside of the vehicle.

Risk of injury.

Risk of damage to the vehicle.

BREAKDOWN RECOVERY

Towing: breakdown

Before towing, set the gearbox to **N** position then wait for around a minute. Unlock the steering column then release the parking brake.

Steering column unlocking

With the card in the passenger compartment, press the engine start button for approximately **two seconds**.

Reposition the lever in **N** position, then wait for around a minute.

Before towing, set the gear lever to **N** position, then wait for around a minute. Unlock the steering column then release the parking brake.

Steering column unlocking

With the card in the passenger compartment, press the engine start button for approximately **two seconds**.

Set the lever to **N** position, then wait for around a minute.

The steering column unlocks and the accessory functions are powered: you can use the vehicle's lights (direction indicators, brake lights, etc.). At night the vehicle must have its lights on.

Depending on the vehicle, once you have finished towing, press the engine start button twice (risk of running down the battery).

The speed specified by current legislation for towing must always be observed. If you are driving the towing vehicle, do not exceed the maximum towing weight for your vehicle → **360**.

Towing or recovering your vehicle on a flatbed

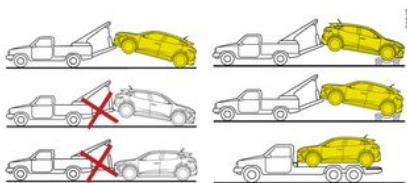

Transport the vehicle on a trailer or tow it with the front wheels off the ground.

Before towing or recovering your vehicle on a flatbed, respect the following instructions:

- with the card in the detection zone, press the engine start button for approximately **two seconds**;
- set the gear lever to **N** position;
- the accessories functions are supplied: you can use the vehicle lighting functions (direction indicators, brake lights, etc.).
- once you have finished towing, press the engine start button twice.



When the engine is stopped, steering and braking assistance are no longer provided.



Leave the card in the vehicle during towing.
Risk of the steering column locking.

Access to towing points

Use only the front 4 and rear 6 towing points (never use the driveshafts or any other part of the vehicle). These towing points may only be used for pulling. They must never be used for lifting the vehicle directly or indirectly.

BREAKDOWN RECOVERY

Front towing point

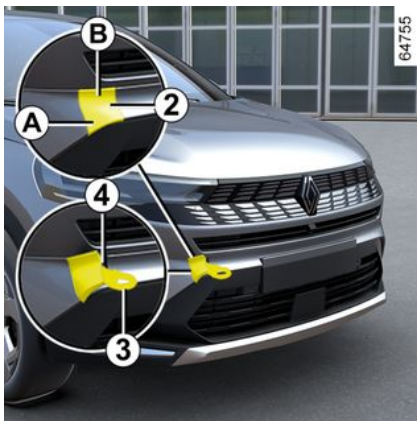

Press zone **A** and maintain the pressure while pulling on zone **B** to open the flap **2**.

Rear towing point

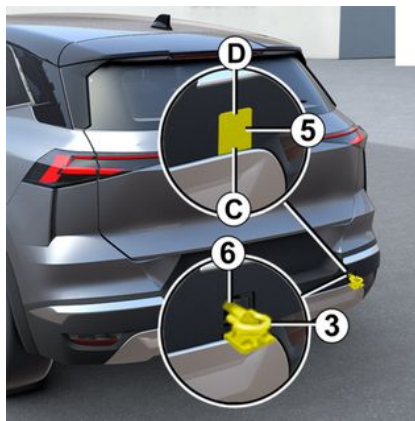

Press zone **C** and maintain the pressure while pulling on zone **D** to open the flap **5**.

Tighten the towing hitch 3 to the maximum: first tighten by hand as far as possible, then finish by locking it using the wheel brace or, depending on the vehicle, using the lever.

You must only use the towing ring **3** and the wheel brace or the lever stored with the tools → **327**.



Ensure that the towing ring is bolted correctly.
Risk of losing the towed object.



- Use a rigid tow bar. If a rope or cable is used (where the law allows this), the vehicle being towed must be able to brake.
- a vehicle must not be towed if it is not fit to be driven.
- avoid accelerating or braking suddenly when towing, as this may result in damage being caused to the vehicle.
- In any case, it is advisable not to exceed **16 mph (25 km/h)**.



Do not leave the tools unsecured inside the vehicle as they may be projected during braking.

BREAKDOWN RECOVERY

Battery: breakdown recovery

To avoid all risk of sparks:

- Ensure that the "energy consumers" (ceiling lights, etc.) are switched off before disconnecting or reconnecting a battery;
- when charging, switch off the charger before connecting or disconnecting the battery;
- do not place any metal objects on the battery as this may create a short circuit across the terminals;
- wait for at least five minutes after switching off the engine before disconnecting the battery;
- make sure that you reconnect the battery terminals after refitting.



Depending on the vehicle, in the event of a battery fault (disconnected, discharged battery, etc.), the steering wheel angle must be reset ➔ 120.



Before carrying out any action in the engine compartment, you must switch off the ignition

➔ 140.

Connecting a battery charger

The battery charger must be compatible with a battery with nominal voltage of 12 volts.

Do not disconnect the battery while the engine is running. **Follow the instructions given by the manufacturer of the battery charger you are using.**



Special procedures may be required to charge some batteries. Contact your approved dealer.

Avoid all risk of sparks which may cause an immediate explosion, and charge the battery in a well ventilated area.

Risk of serious injury.



Handle the battery with care as it contains sulphuric acid which must not come into contact with the eyes or skin. If it does, wash the affected area with plenty of cold water. If necessary, consult a doctor.

Keep any flames, red hot objects or sparks away from the battery components (**risk of explosion**). Please note when working close to the engine that it may be hot. The engine cooling fan may also

start at any moment. The  label in the engine compartment reminds you of this.

Risk of injury.

Secondary "12 V" battery: breakdown recovery

Starting the vehicle using the battery from another vehicle

If the secondary "12 V" battery charge level is too low, it is possible to use the battery of another vehicle to re-activate and operate the hybrid system ➔ 140.

BREAKDOWN RECOVERY

As the battery cannot be directly accessed, it is necessary to use the remote terminals located in the engine compartment.

Obtain suitable leads (large cross-section) from an approved dealer. If you already have jump leads, ensure that they are in good condition.

The two batteries must have an identical nominal voltage: 12 V. The battery supplying the current should have a capacity (amp-hours, Ah) which is at least the same as that of the discharged battery.

Ensure that there is no risk of contact between the two vehicles (risk of short circuiting when the positive terminals are connected) and that the discharged battery is properly connected. Switch off your vehicle ignition.

Start the engine of the vehicle supplying the current and run it at an intermediate engine speed.

 Do not use your hybrid vehicle to restart a "12 V" battery in another vehicle. The electrical power in the secondary "12 V" battery of a hybrid vehicle is not sufficient for this operation.
Risk of damage to the vehicle.



Please note when working close to the engine that it may be hot. The engine cooling fan may also start at any moment. The



label in the engine compartment reminds you of this.
Risk of injury.



Do not carry out any work under the bonnet while the vehicle is charging or while the ignition is switched on → 140.

Remote terminals

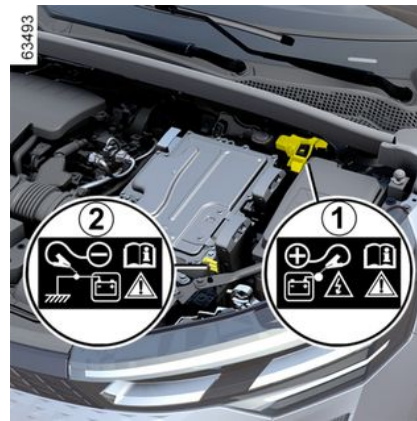
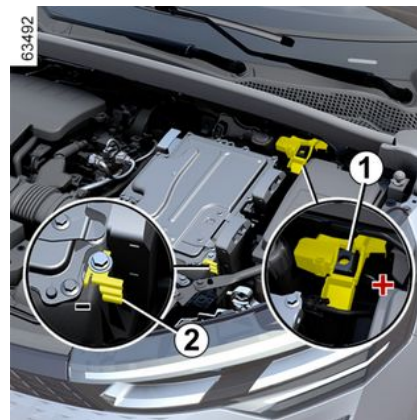

Use **terminal 1 (+)** and **terminal 2 (-)** in the engine compartment.

BREAKDOWN RECOVERY



It is forbidden to disconnect the positive cable in the engine compartment.

Risk of the engine starting inadvertently.
Risk of burns by projection of sparks.

63488



Note: open the cover **3** of terminal **1** (+) by pressing the button **4** in the direction indicated by the arrow.

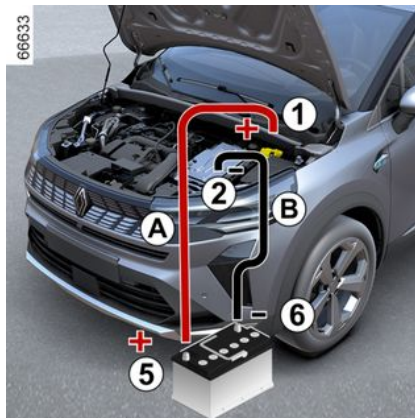

Attach the positive cable **A** to terminal **1** (+), then to terminal **5** (+) of the battery supplying the current.

Attach the negative cable **B** to terminal **6** (-) of the battery supplying the current and then to terminal **2** (-).

Press the start button and, as soon as the ignition is switched on, disconnect cables **A** and **B** in the reverse order (**1 - 5 - 6 - 2**).



Ensure that there is no contact between cables **A** and **B** and that positive cable **A** is not in contact with any metallic component in the vehicle supplying the current.

Risk of injury and/or damage to the vehicle.

63489

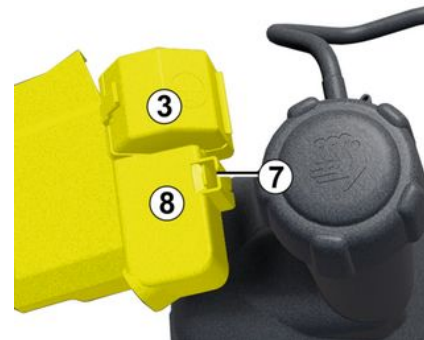

Each time you have used the cover **3**, check that the cover of terminal **8** is attached correctly to its tab **7**.

BREAKDOWN RECOVERY

Special features of E-Tech Full Hybrid vehicles

If the secondary "12 V" battery charge level is too low, it is possible to use the battery of another vehicle to re-activate and operate the hybrid system ➔ 140.

As the battery cannot be directly accessed, it is necessary to use the remote terminals located in the engine compartment.

Obtain suitable leads (large cross-section) from an approved dealer. If you already have jump leads, ensure that they are in good condition.

The two batteries must have an identical nominal voltage: 12 V. The battery supplying the current should have a capacity (amp-hours, Ah) which is at least the same as that of the discharged battery.

Ensure that there is no risk of contact between the two vehicles (risk of short circuiting when the positive terminals are connected) and that the discharged battery is properly connected. Switch off your vehicle ignition.

Start the engine of the vehicle supplying the current and run it at an intermediate engine speed.



Do not use your hybrid vehicle to restart a "12 V" battery in another vehicle. The electrical power in the secondary "12 V" battery of a hybrid vehicle is not sufficient for this operation.

Risk of damage to the vehicle.



Please note when working close to the engine that it may be hot. The engine cooling fan may also start at any moment. The



label in the engine compartment reminds you of this.

Risk of injury.



Do not carry out any work under the bonnet while the vehicle is charging or while the ignition is switched on ➔ 140.

HEADLIGHTS, LIGHTS: REPLACING BULBS

Exterior lighting: replacing bulbs



To replace LED bulbs, consult an approved dealer.

Front headlights

Changing bulbs

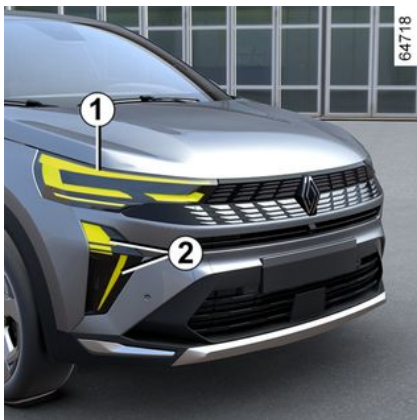

Daytime running lights/side lights 1

Consult an approved dealer.

LED main beam headlights/dipped beam headlights/direction indicator lights 2

Consult an approved dealer.

Rear and indicator lights



LED side lights, direction indicator lights, brake lights 3

Consult an approved dealer.

LED reversing lights and fog lights 4

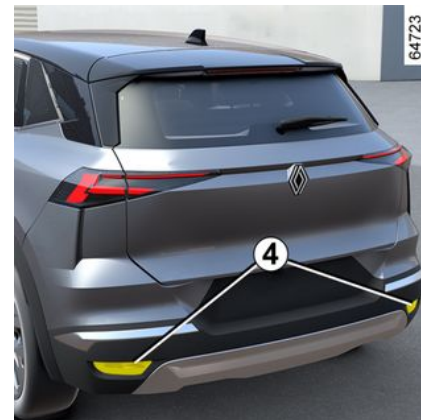

Consult an approved dealer.

HEADLIGHTS, LIGHTS: REPLACING BULBS

LED high-level brake light 5



Consult an approved dealer.

Number plate lights 6

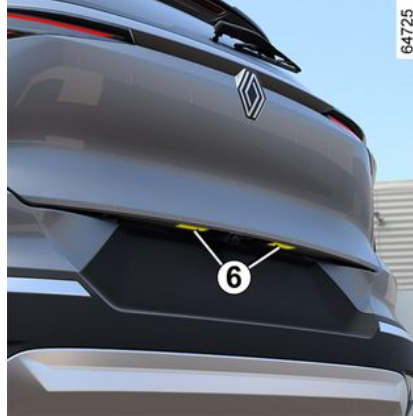

Consult an approved dealer.

LED side repeaters 7

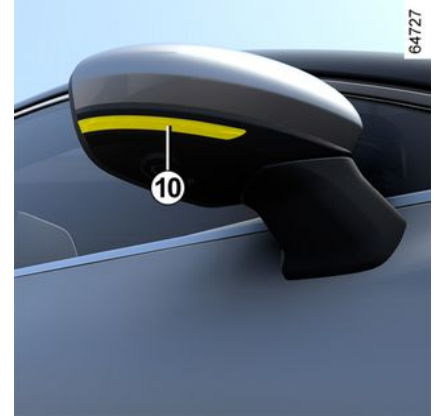

Consult an approved dealer.

HEADLIGHTS, LIGHTS: REPLACING BULBS

Interior lighting: changing bulbs

Courtesy light/Reading spot lights bulbs *A*, *B* and *C*



Consult an approved dealer.

Luggage compartment light



- Unclip the light **1** by pressing the tab to its left (using a flat-bladed screwdriver or similar);
- remove the bulb concerned.

Bulb type: W5W .

HEADLIGHTS, LIGHTS: REPLACING BULBS

Glove box light



- Unclip the light **2** by pressing the tab to its left (using a flat-bladed screwdriver or similar);
- remove the bulb concerned.

Bulb type: W5W .

LED courtesy mirror lights 3



Consult an approved dealer.

Ambient lighting

Consult an approved dealer.

WIPER BLADES: REPLACEMENT

Replacing the windscreen wiper blades 2



To replace the wipers, first put them in the service position **B**.

Engine running or ignition on:

- move the stalk **1** twice in succession to position **A** (single sweep): the wiper blades will stop in the service position **B** away from the bonnet;
- lift the wiper arm **3**;
- lower the tab **4** and remove the blade **2**.

Refitting

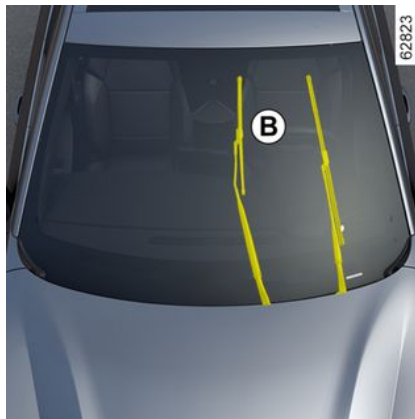

To refit the wiper blade **2**, insert it into its housing in the arm **3**, then clip it until you hear a click. Make sure that the blade is correctly locked in position.

To return the blades to the lowered position, make sure that the blades are folded down onto the windscreen then set the stalk **1** to position **A** (single sweep): the windscreen wiper blades will fold into the bonnet when the ignition is switched on.

41898

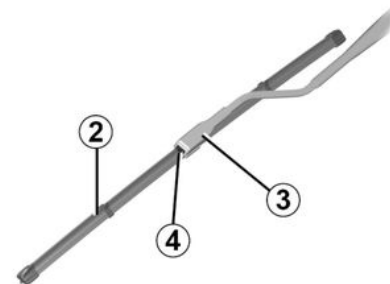

i Check the condition of the wiper blades. You are responsible for their service life:

- clean the blades, windscreen and rear screen regularly with soapy water;
- do not use them when the windscreen or rear screen is dry;
- free them from the windscreen or rear screen when they have not been used for a long time.

WIPER BLADES: REPLACEMENT

Rear screen wiper blade 5

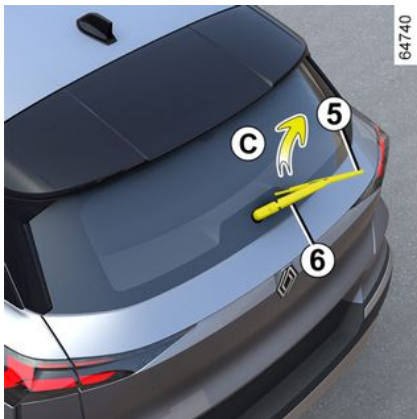

The stalk in the off position (deactivated):

- lift the wiper arm **6**;
- pivot the blade **5** (movement **C**) until it unclips;
- remove the blade by pulling it.

Refitting

To refit the wiper blade, proceed in the reverse order to removal. Make sure that the blade is correctly locked in position.



Check the condition of the wiper blades.

- clean the blades, windscreen and rear screen regularly with soapy water;
- do not use them when the windscreen or rear screen is dry;
- free them from the windscreen or rear screen when they have not been used for a long time.



- In frosty weather, make sure that the wiper blades are not stuck by ice (to avoid the risk of the motor overheating).
- Check the condition of the wiper blades. Replace the wiper blades as soon as they begin to lose efficiency (approximately once a year).

Whilst changing the blade, take care not to drop the arm onto the window after it has been removed as this may break the window.



Before changing the rear wiper blade, make sure the stalk is in the stop position (deactivated).

Risk of injury.

FUSES

Fuse box

If any electrical component does not work, check the condition of the fuses.

Fuses in the passenger compartment **A**

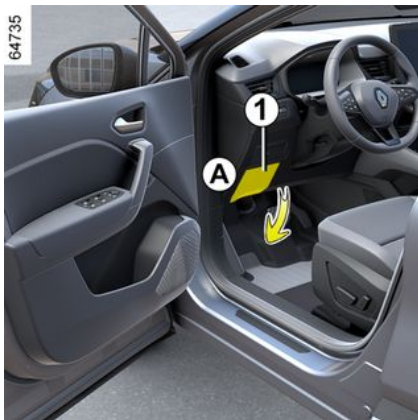

Unclip the flap **1**.



To comply with current legislation, or as a precaution, you can obtain an emergency kit from your approved dealer containing a set of spare bulbs and fuses.

Fuses located in the passenger compartment behind a flap in the glovebox **B**

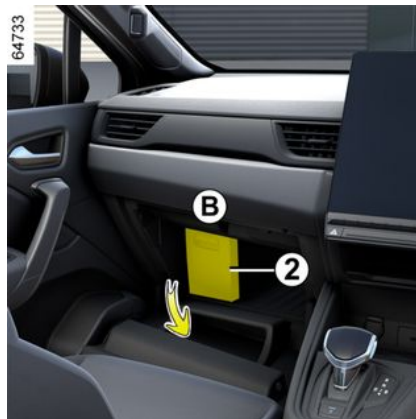

Unclip the flap **2**.

Tweezers **3**

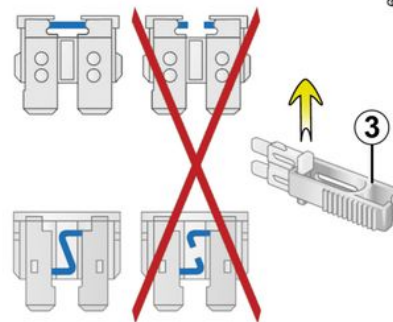

Remove the fuse using the tweezers **3** located on the back of the flap.

To remove the fuse from the tweezers, slide the fuse to the side.

It is not advisable to use the free fuse locations.

FUSES



Check the fuse in question and, **if necessary, replace it (replacement fuse must have the same rating as the original).**

If a fuse is fitted with too high a rating, it may cause the electrical circuit to overheat (risk of fire) in the event of an item of equipment using an excessive amount of current.

Allocation of fuses

(the presence of certain fuse depends on the vehicle equipment level)

FUSES

Number	Allocation
1	Heated rear view mirrors
2	Driver's and passenger's heated seat
3	Trailer traction
4	Rear wiper and rear fog lights
5	Hazard warning lights without MCB
6	Brake lights without MCB
7	Radio
8	Rear screen de-icing
9	Manual air conditioning, Radio, Gateway ECU, Interior rear view mirror, Seat belt, Heated windscreen
10	Front USB
11	Luggage compartment accessories socket, towing device
12	Depending on the vehicle, heated seats
13	Hazard warning lights with MCB

Number	Allocation
14	Brake lights with MCB
15	One-touch windows for the front passenger seat
16	Rear USB
17	Rear view mirror control
18	One-touch windows for the rear right-hand seat
19	One-touch windows
20	One-touch windows for the rear left-hand seat
21	External and internal welcome sound
22	Courtesy light
23	Assisted parking button
24	Pre-equipment for accessories
25	Pre-equipment for accessories
26	12 V socket, Cigarette lighter
27	Heated steering wheel
28	Windscreen washer liquid pump switch



Fuses in the engine compartment C

Some functions are protected by fuses located in the engine compartment (unit **C**).

However, because of their reduced accessibility, **we advise you to have your fuses replaced by an approved Dealer.**

FUSES



Please note when working close to the engine that it may be hot. The engine cooling fan may also start at any moment. The



label in the engine compartment reminds you of this.

Risk of injury.



Before carrying out any action in the engine compartment, you must switch off the ignition

→ 140.

6



Electrical and electronic accessories

Before installing this type of accessory (particularly for transmitters/receivers: frequency bandwidth, power level, position of the aerial, etc.), make sure it is compatible with your vehicle. Contact an approved dealer.

Before connecting an accessory to a socket, ensure that it does not exceed the maximum power authorised for

the socket → 293, → 299.

Fire hazard.

No work may be carried out on the vehicle's electrical and/or electronic circuits, except by a qualified professional. In fact, an incorrect connection and/or the installation of electrical/electronic accessories not approved by the manufacturer could lead to:

- damage to the electrical and/or electronic equipment;
- damage to the components connected to it;
- the collection and use of vehicle data;
- an invasion of privacy (modification, deletion or unwarranted access to personal data);
- cancellation of the authorisation for entry into service.

Risk of serious accidents.

Risk of invasion of privacy.

If you have electrical equipment fitted in future, make sure that you obtain information on the rating and position of this fuse.

Using the diagnostic socket

The use of electronic accessories on the diagnostic socket may cause serious disturbance to the vehicle's electronic systems. For your safety, we recommend that you only use electronic accessories approved by the manufacturer: consult an approved dealer.

Risk of serious accidents

Fitting aftermarket accessories

If you wish to install accessories on the vehicle: consult an approved dealer. Also, to ensure the correct operation of your vehicle, and to avoid any risk to your safety, we recommend that you use only accessories specifically designed for your vehicle, which are the only accessories for which the manufacturer will provide a warranty.

If you are using an anti-theft device, only attach it to the brake pedal.

Driver obstruction

INSTALLATION AND USE OF ACCESSORIES

On the driver's side, only use mats suitable for the vehicle, attached with the pre-fitted components, and check the fitting regularly. Do not lay one mat on top of another.

There is a risk of wedging the pedals.

OPERATING FAULTS

The following advice will enable you to carry out quick, temporary repairs. For safety reasons you should always contact an approved dealer as soon as possible.

Using the card	POSSIBLE CAUSES	ACTION REQUIRED
The card does not lock or unlock the doors.	Card battery is flat.	Replace the battery. You will still be able to lock/unlock and start your ➔ 39 and ➔ 140 vehicle.
	Use of appliances operating on the same frequency as the card (mobile phone, etc.).	Stop using the devices or use the built-in key ➔ 39.
	Vehicle located in an area with strong electromagnetic radiation. Vehicle battery discharged.	Use the key that is built into the card ➔ 39.
	The "Place card in zone + START" message appears on the instrument panel.	Place you card on the placement area ➔ 140 then press the START button.
	The vehicle is started.	While the engine is on, it is not possible to lock/unlock using the card. Turn off the ignition.
	Desynchronisation of the card	Unlock the driver's door by inserting the card's built-in key into the door lock ➔ 39, then place the card on the placement area ➔ 140 and press the START button to synchronise the card.

The starter is activated	POSSIBLE CAUSES	ACTION REQUIRED
The instrument panel indicator lights are weak or fail to light up and the starter does not turn.	Battery terminals not tight, battery terminals disconnected or oxidised.	Retighten, reconnect or clean them if they are oxidised.
	Discharged battery or not operational.	Connect another battery to the faulty battery ➔ 334 or replace the battery if necessary. Do not push the vehicle if the steering column is locked.
	Faulty circuit.	Consult an approved dealer.

OPERATING FAULTS

The starter is activated	POSSIBLE CAUSES	ACTION REQUIRED
The engine will not start.	Starting conditions are not fulfilled. The "hands-free" card does not work.	➔ 140 . Place the card in the recess provided for this purpose on the centre console ➔ 140.
With the vehicle stationary, engine cold, the engine's idle speed is high.	Petrol version, this is not necessarily a fault. This may be caused by the increase in the engine temperature.	The engine's idle speed should decrease after about one minute. Otherwise, this may be caused by another fault. Call an approved dealer.
The engine cannot be switched off.	Card not detected. Electronic fault.	Place the card in the recess provided for this purpose on the centre console. Press and hold the start button. Press the start button 3 times quickly or press and hold.
The steering column remains locked.	Steering wheel locked. Faulty electrical circuit.	Move the steering wheel while pressing the engine start button ➔ 140. Consult an approved dealer.
On the road	POSSIBLE CAUSES	ACTION REQUIRED
Vibrations.	Tyres not inflated to the correct pressure, incorrectly balanced or damaged.	Check the tyre pressures: if this is not the cause, have their condition checked by an approved dealer.
White smoke from the exhaust.	This is not necessarily a fault. Depending on the climate conditions (cold, humidity etc.), smoke may be produced under hard vehicle acceleration.	Reduce the engine speed and avoid sudden acceleration to gradually make the smoke disappear. Otherwise, this may be caused by another fault. Consult an approved dealer.
Smoke under the bonnet.	Short-circuit or cooling system leak.	Stop, switch off the ignition, stand away from the vehicle and contact an approved dealer.

OPERATING FAULTS

On the road	POSSIBLE CAUSES	ACTION REQUIRED
<p>The oil pressure warning light comes on:</p> <p>while cornering or braking.</p> <p>is slow to go out or remains lit up under acceleration.</p>	<p>The level is too low.</p> <p>Loss of oil pressure.</p>	<p>Add engine oil → 309 .</p> <p>Stop the vehicle and contact an approved dealer.</p>
On the road	POSSIBLE CAUSES	ACTION REQUIRED
Steering becomes heavy.	<p>Assistance overheating.</p> <p>Fault with the electric assistance motor.</p> <p>Fault in the assistance system</p>	<p>Drive carefully at reduced speed, be aware of the level of force in the steering wheel needed to turn the wheels.</p> <p>Consult an approved dealer.</p>
The engine is overheating. The coolant temperature indicator is in the warning zone and warning light STOP comes on.	<p>Engine cooling fan not working.</p> <p>Coolant leaks.</p>	<p>Stop the vehicle, switch off the engine and contact an approved dealer.</p> <p>Check the coolant reservoir: it should contain fluid. If there is no coolant, consult an approved dealer as soon as possible.</p>
Coolant boiling in the coolant reservoir.	Mechanical fault: damaged cylinder head gasket.	<p>Stop the engine.</p> <p>Call an approved dealer.</p>

OPERATING FAULTS



Radiator: in the event of a significant lack of coolant, remember that you must never top up using cold coolant while the engine is very hot. After any procedure on the vehicle which has involved even partial draining of the cooling system, it must be refilled with a new mixture prepared in the correct proportions. Reminder: only products approved by our Technical Department may be used for this purpose.

Electrical equipment	POSSIBLE CAUSES	ACTION REQUIRED
The wipers do not work.	Wiper blades stuck.	Free the blades before using the wipers.
	Faulty electrical circuit.	Consult an approved dealer.
	Fuse damaged.	Replace the fuse or have it replaced → 344.
The wiper does not stop.	Faulty electrical controls.	Consult an approved dealer.
Direction indicators flashing more quickly.	Blown rear bulb.	→ 338 .
The indicators are not working.	Faulty electrical circuit or control.	Consult an approved dealer.
	Fuse damaged.	Replace the fuse or have it replaced → 344.
The headlights do not switch on or off.	Faulty electrical circuit or control.	Consult an approved dealer.
	Fuse damaged.	Replace the fuse or have it replaced → 344.

Electrical equipment	POSSIBLE CAUSES	ACTION REQUIRED
Traces of condensation in the headlights or rear lights.	Traces of condensation may be a natural phenomenon caused by variations in temperature and humidity. In this case, the traces will disappear slowly once the lights are switched on.	
The front seat belt reminder warning light comes on when the seat belts are fastened.	An object is stuck between the floor and the seat and is disrupting the operation of the sensor.	Remove all objects from underneath the front seats.

INFORMATION ABOUT THE VEHICLE

Vehicle identification plates

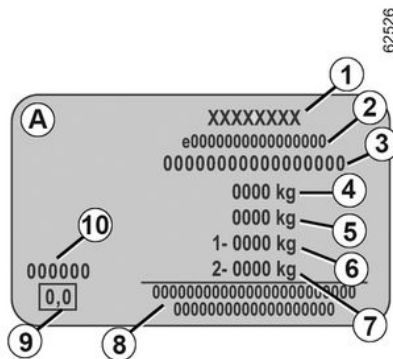
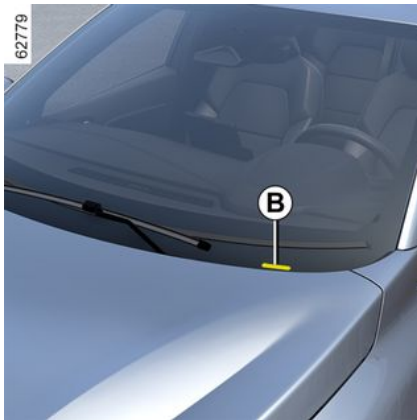

The information shown on the vehicle identification plate should be quoted on all correspondence or orders.

The presence and location of the information depends on the vehicle.

Identification plate A

1. Manufacturer name.
2. EC design number or approval number.
3. Identification number.

B. Depending on the vehicle, this information is also provided on the marking .

4. MMAC (Maximum Permissible All-up Weight).

5. MTR (Gross Train Weight: vehicle fully loaded, with trailer).

6. MMTA (Maximum Permissible Weight) on front axle.

7. MMTA on rear axle.

8. Reserved for related or additional entries.

9. Not used.

10. Paint reference (colour code).

Technical Information for the emergency services

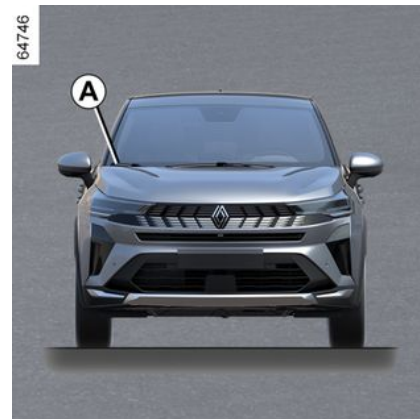

The QR Code on label A allows emergency workers using a tablet or smart-phone to immediately access the tech-

INFORMATION ABOUT THE VEHICLE

nical information useful for working on the vehicle in the event of an accident.

Ensure that the label **A** is always visible and present on the windscreen as well as the rear screen.

Any modification or damage would prevent access to the information.

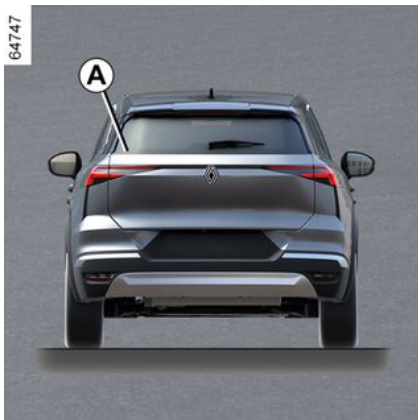

Engine identification, engine specifications

Engine identification

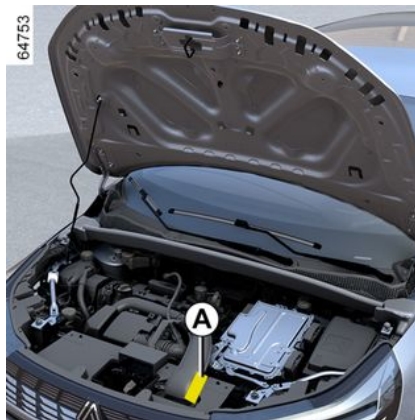

33293

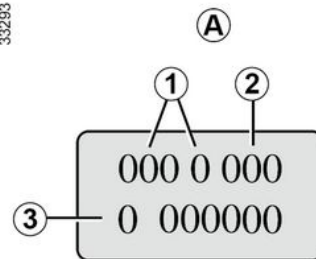



Please quote the engine identification information in area A in all correspondence or orders.

(Location varies depending on engine)

1. Engine type.
2. Engine suffix.
3. Engine serial number.

INFORMATION ABOUT THE VEHICLE

Engine specifications

Versions	E-Tech Full Hybrid	
Engine type (see engine plate)	H4M	5DH
Cubic capacity (cc)	1598	-
Type of fuel Octane rating	Petrol It is essential to use unleaded petrol with an octane rating matching that indicated on the label affixed on the fuel filler flap ➔ 137.	-
Fuel types that meet European standards and are compatible with the engines of vehicles sold in Europe (in any other case, contact an Approved Dealer).	 E5	Unleaded petrol compliant with standard EN 228 containing up to 5% ethanol in volume.
	 E10	Unleaded petrol compliant with standard EN 228 containing up to 10% ethanol in volume.
Spark plugs	Only use the spark plugs specified for your vehicle's engine. The type should be marked on a label affixed inside the engine compartment. If it is not then contact an approved Dealer. Fitting spark plugs which are not to specification may damage the engine.	-

INFORMATION ABOUT THE VEHICLE

Dimensions (in metres)

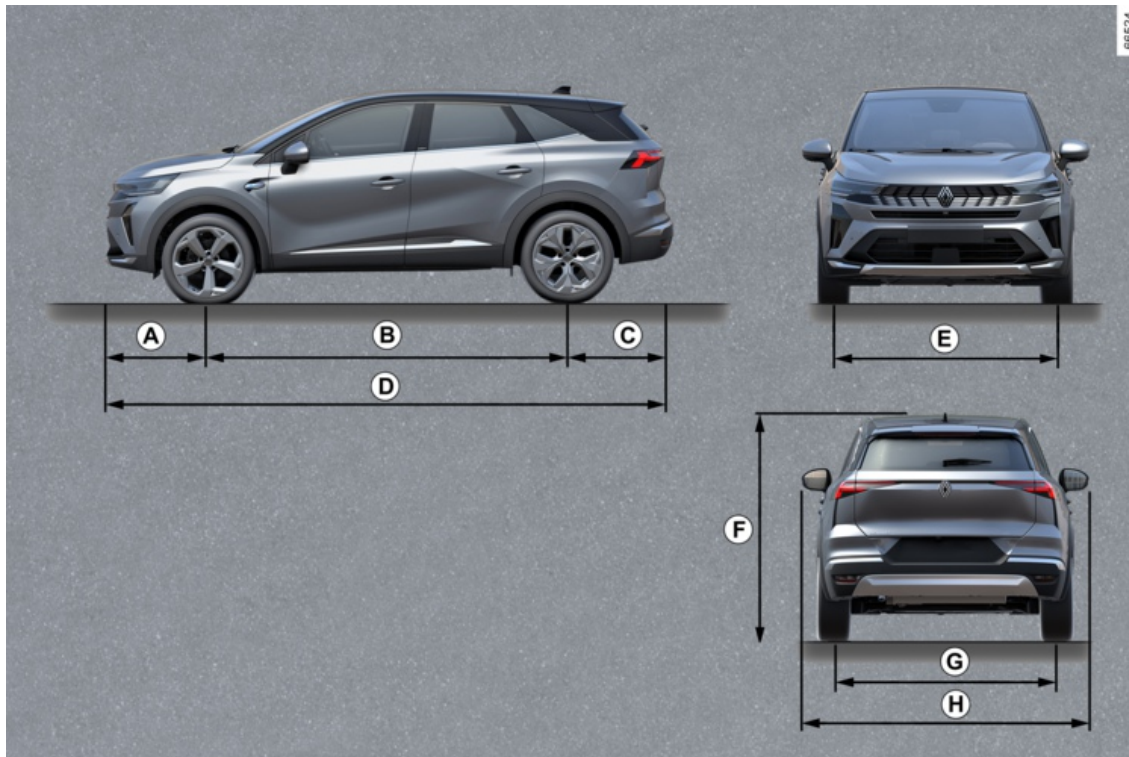

7

INFORMATION ABOUT THE VEHICLE

	Length
A	0,882
B	2,639
C	0,891
D	4,412
E	1,560
F	1,575 unladen
G	1,555
H	1,797 2.023 with door mirrors folded out 1.816 with door mirrors folded in

INFORMATION ABOUT THE VEHICLE

Weights (in kg)

The weights indicated are for a basic vehicle without optional fittings: they vary according to your vehicle's equipment. Consult your approved Dealer.	
Maximum Permissible All-up Weight (MMAC) Maximum Permissible Weight (MMTA) Gross Train Weight (MTR)	Weights indicated on the manufacturer's plate → 355
Braked Towing Weight *	found by calculating: MTR - MMAC
Unbraked Towing Weight *	745 kg
Permissible nose weight *	75 kg
Maximum permissible load on roof	80 kg (including carrying device)
<p>* Towing weight (towing a caravan, boat, etc.)</p> <p>Towing is prohibited when the MTR - MMAC calculation is equal to zero, or when the MTR is equal to zero (or is not indicated) on the manufacturer's plate.</p> <ul style="list-style-type: none">– It is important to respect local towing regulations in force, specifically those set out in the Highway Code. Contact an approved Dealer for any modifications to towing equipment.– For vehicles fitted with a trailer, the total train weight (vehicle + trailer) must never be exceeded. However the following is tolerated:<ul style="list-style-type: none">– rear MMTA exceeded by up to 15%,– MMAC exceeded by up to 10% or 100 kg (whichever limit is reached first). <p>In either case, the maximum speed of the vehicle and trailer must not exceed 62 mph (100 km/h) and the tyre pressures must be increased by 0.2 bar (3 psi).</p> <ul style="list-style-type: none">– The engine output and climbing capability are reduced with altitude. We recommend that the maximum load be reduced by 10% at an altitude of 1,000 metres and by an additional 10% for each 1,000 metres thereafter.	

REPLACEMENT PARTS AND REPAIRS

Original parts are based on very stringent specifications and are subjected to specific tests. Therefore, they are of at least the same level of quality as the parts fitted originally.

If you always fit genuine replacement parts to your vehicle, you will ensure that it performs well. Furthermore, repairs carried out in the approved dealer network with original parts are guaranteed according to the conditions stated on the back of the repair order.

SERVICE SHEETS

VIN:

Date:	Miles (km):	Invoice number:	Comments/miscellaneous
Type of operation: Service <input type="checkbox"/> <input type="checkbox"/>		Stamp	
Anticorrosion check: OK <input type="checkbox"/> Not OK* <input type="checkbox"/>			
Date:	Miles (km):	Invoice number:	Comments/miscellaneous
Type of operation: Service <input type="checkbox"/> <input type="checkbox"/>		Stamp	
Anticorrosion check: OK <input type="checkbox"/> Not OK* <input type="checkbox"/>			
Date:	Miles (km):	Invoice number:	Comments/miscellaneous
Type of operation: Service <input type="checkbox"/> <input type="checkbox"/>		Stamp	
Anticorrosion check: OK <input type="checkbox"/> Not OK* <input type="checkbox"/>			

7

* See specific page

SERVICE SHEETS

VIN:

Date:	Miles (km):	Invoice number:	Comments/miscellaneous
Type of operation: Service <input type="checkbox"/> <input type="checkbox"/>		Stamp	
Anticorrosion check: OK <input type="checkbox"/> Not OK* <input type="checkbox"/>			
Date:	Miles (km):	Invoice number:	Comments/miscellaneous
Type of operation: Service <input type="checkbox"/> <input type="checkbox"/>		Stamp	
Anticorrosion check: OK <input type="checkbox"/> Not OK* <input type="checkbox"/>			
Date:	Miles (km):	Invoice number:	Comments/miscellaneous
Type of operation: Service <input type="checkbox"/> <input type="checkbox"/>		Stamp	
Anticorrosion check: OK <input type="checkbox"/> Not OK* <input type="checkbox"/>			

* See specific page

SERVICE SHEETS

VIN:

Date:	Miles (km):	Invoice number:	Comments/miscellaneous
Type of operation: Service <input type="checkbox"/> <input type="checkbox"/>		Stamp	
Anticorrosion check: OK <input type="checkbox"/> Not OK* <input type="checkbox"/>			
Date:	Miles (km):	Invoice number:	Comments/miscellaneous
Type of operation: Service <input type="checkbox"/> <input type="checkbox"/>		Stamp	
Anticorrosion check: OK <input type="checkbox"/> Not OK* <input type="checkbox"/>			
Date:	Miles (km):	Invoice number:	Comments/miscellaneous
Type of operation: Service <input type="checkbox"/> <input type="checkbox"/>		Stamp	
Anticorrosion check: OK <input type="checkbox"/> Not OK* <input type="checkbox"/>			

7

* See specific page

SERVICE SHEETS

VIN:

Date:	Miles (km):	Invoice number:	Comments/miscellaneous
Type of operation: Service <input type="checkbox"/> <input type="checkbox"/>		Stamp	
Anticorrosion check: OK <input type="checkbox"/> Not OK* <input type="checkbox"/>			
Date:	Miles (km):	Invoice number:	Comments/miscellaneous
Type of operation: Service <input type="checkbox"/> <input type="checkbox"/>		Stamp	
Anticorrosion check: OK <input type="checkbox"/> Not OK* <input type="checkbox"/>			
Date:	Miles (km):	Invoice number:	Comments/miscellaneous
Type of operation: Service <input type="checkbox"/> <input type="checkbox"/>		Stamp	
Anticorrosion check: OK <input type="checkbox"/> Not OK* <input type="checkbox"/>			

* See specific page

SERVICE SHEETS

VIN:

Date:	Miles (km):	Invoice number:	Comments/miscellaneous
Type of operation: Service <input type="checkbox"/> <input type="checkbox"/>		Stamp	
Anticorrosion check: OK <input type="checkbox"/> Not OK* <input type="checkbox"/>			
Date:	Miles (km):	Invoice number:	Comments/miscellaneous
Type of operation: Service <input type="checkbox"/> <input type="checkbox"/>		Stamp	
Anticorrosion check: OK <input type="checkbox"/> Not OK* <input type="checkbox"/>			
Date:	Miles (km):	Invoice number:	Comments/miscellaneous
Type of operation: Service <input type="checkbox"/> <input type="checkbox"/>		Stamp	
Anticorrosion check: OK <input type="checkbox"/> Not OK* <input type="checkbox"/>			

7

* See specific page

SERVICE SHEETS

VIN:

Date:	Miles (km):	Invoice number:	Comments/miscellaneous
Type of operation: Service <input type="checkbox"/> <input type="checkbox"/>		Stamp	
Anticorrosion check: OK <input type="checkbox"/> Not OK* <input type="checkbox"/>			
Date:	Miles (km):	Invoice number:	Comments/miscellaneous
Type of operation: Service <input type="checkbox"/> <input type="checkbox"/>		Stamp	
Anticorrosion check: OK <input type="checkbox"/> Not OK* <input type="checkbox"/>			
Date:	Miles (km):	Invoice number:	Comments/miscellaneous
Type of operation: Service <input type="checkbox"/> <input type="checkbox"/>		Stamp	
Anticorrosion check: OK <input type="checkbox"/> Not OK* <input type="checkbox"/>			

* See specific page

ANTICORROSION CHECK

If the continuation of the warranty is subject to repair, it is indicated below.

VIN:

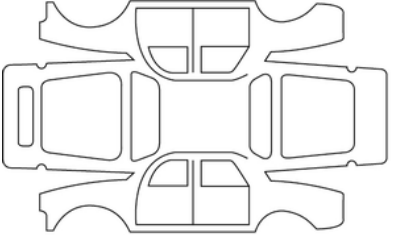
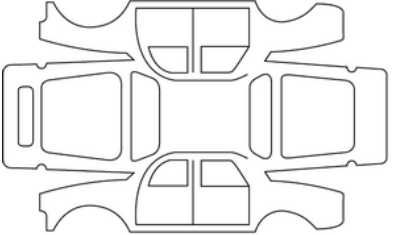
Date of repair:		Stamp
Corrosion repair operation to be carried out:		
Date of repair:		Stamp
Repair to be carried out:		

7

ANTICORROSION CHECK

If the continuation of the warranty is subject to repair, it is indicated below.

VIN:

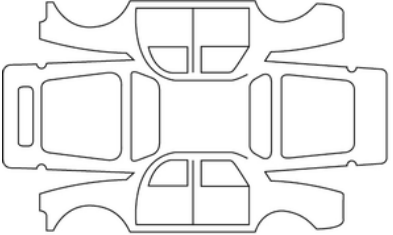
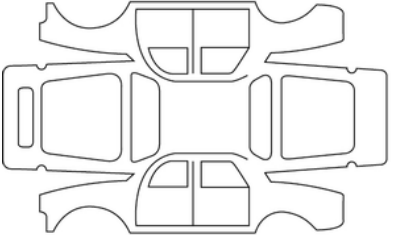
Date of repair:		Stamp
Corrosion repair operation to be carried out:		
Date of repair:		Stamp
Repair to be carried out:		

ANTICORROSION CHECK

If the continuation of the warranty is subject to repair, it is indicated below.

VIN:

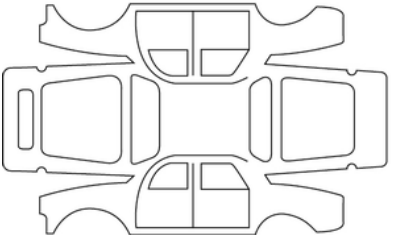
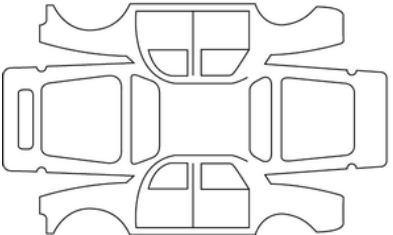
Date of repair:		Stamp
Corrosion repair operation to be carried out:		
Date of repair:		Stamp
Repair to be carried out:		

7

ANTICORROSION CHECK

If the continuation of the warranty is subject to repair, it is indicated below.

VIN:

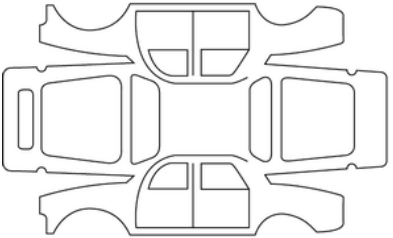
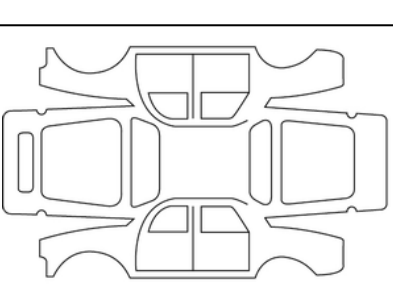
Date of repair:		Stamp
Corrosion repair operation to be carried out:		
Date of repair:		Stamp
Repair to be carried out:		

ANTICORROSION CHECK

If the continuation of the warranty is subject to repair, it is indicated below.

VIN:

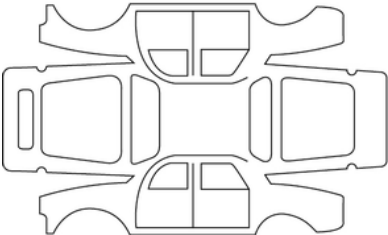
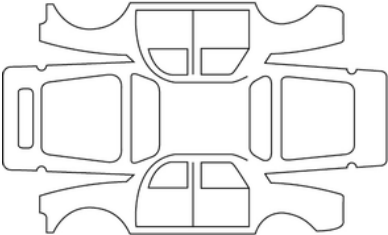
Date of repair:		Stamp
Corrosion repair operation to be carried out:		
Date of repair:		Stamp
Repair to be carried out:		

7

ANTICORROSION CHECK

If the continuation of the warranty is subject to repair, it is indicated below.

VIN:

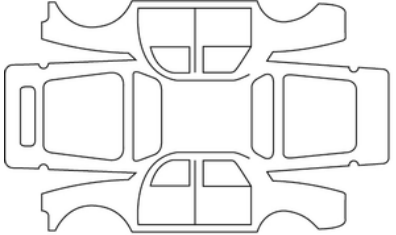
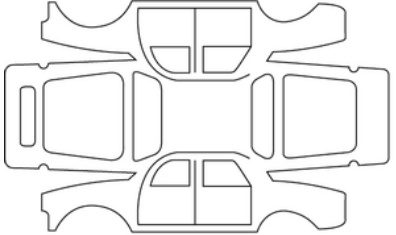
Date of repair:		Stamp
Corrosion repair operation to be carried out:		
Date of repair:		Stamp
Repair to be carried out:		

ANTICORROSION CHECK

If the continuation of the warranty is subject to repair, it is indicated below.

VIN:

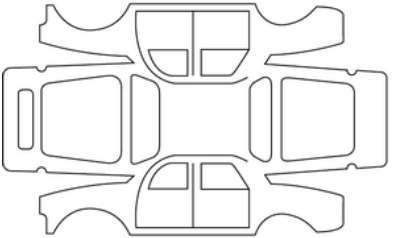
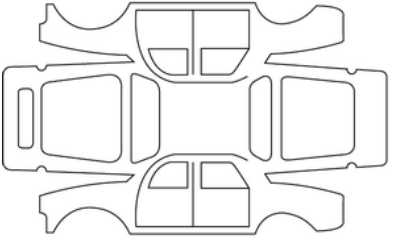
Date of repair:		Stamp
Corrosion repair operation to be carried out:		
Date of repair:		Stamp
Repair to be carried out:		

7

ALPHABETICAL INDEX

Symbols

"Hands-free" card: battery, [35](#), [35](#)

A

ABS, [167](#)

Accessing the vehicle, [32](#)

Accessories: accessory sockets, [299](#)

Accessories socket, [299](#)

Access to the engine compartment, [308](#)

Active driver assist, [209](#)

Active emergency braking, [195](#)

Adaptive cruise control, [234](#)

Additional tank capacity, [100](#)

Adjusting the front seats, [49](#), [49](#)

Adjusting your driving position, [49](#), [49](#), [55](#), [124](#)

Airbag, [60](#), [65](#), [65](#), [76](#), [80](#), [88](#), [92](#)

Airbag : activating the front passenger airbag, [92](#)

Airbag : deactivating the front passenger airbag, [92](#)

Airbag activating the front passenger airbags, [80](#), [88](#), [92](#)

Airbag deactivating the front passenger airbag, [80](#), [88](#), [92](#)

Airbag inflatable cushion, [60](#), [65](#)

Airbags : child safety, [92](#)

Air conditioning, [287](#), [287](#)

Air conditioning: air outlets: vents, [285](#)

Air conditioning: information and advice for use, [290](#)

Air Vents, [285](#), [285](#)

Anti-lock braking system: ABS, [167](#)

Assistance: driving aid, [234](#)

Assisted parking, [261](#)

Audible and visual signals, [130](#), [130](#)

Autohold, [153](#), [153](#)

Automatic gearbox (use), [143](#)

Automatic gearbox selector lever, [143](#)

Automatic tailgate, [43](#), [43](#)

AUTO mode, [124](#)

B

Batteries, [35](#)

Battery, [316](#)

Battery: troubleshooting, [334](#)

Blinds, sun visor, [299](#)

Blind spot: warning, [186](#)

Blind spot warning, [186](#)

Bonnet, [308](#), [308](#)

Brake, [153](#), [153](#)

Breakdown recovery towing, [332](#)

C

Card, [32](#)

Card: battery, [35](#)

Card: emergency key, [30](#)

Card: engine not starting in hands-free mode, [30](#)

Card: hands-free, [30](#)

Card: locking/unlocking the opening elements, [30](#)

Card: use, [32](#)

Catalytic converter, [148](#)

ALPHABETICAL INDEX

Central door locking, [32](#), [39](#), [42](#)
Changing a wheel, [330](#)
Changing bulbs, [338](#)
Changing gears, [143](#), [157](#)
Children, [68](#), [76](#), [80](#), [88](#), [92](#)
Children (safety), [295](#)
Child restraint, [68](#), [76](#), [80](#), [88](#)
Child restraint devices, [68](#), [76](#), [80](#), [88](#)
Child restraint system, [68](#), [76](#), [80](#), [88](#)
Child safety, [32](#), [68](#), [68](#), [76](#), [80](#), [88](#), [92](#), [295](#)
Child seats, [68](#), [74](#), [76](#), [80](#), [88](#)
Cleaning: vehicle interior, [319](#)
Clock, [114](#), [114](#)
Closing the doors, [32](#), [38](#), [38](#), [39](#)
Configuration menu, [112](#)
Configuration menu settings, [112](#)
Control instruments, [100](#), [111](#), [114](#)
Control warning lights, [100](#), [111](#)
Coolant level, [312](#)
Cruise control, [226](#), [230](#), [234](#)
Cruise control - Speed limiter, [226](#), [230](#)
Customising the vehicle settings, [112](#)

D

Daytime running lights, [124](#)
De-icing/demisting the windscreen, [287](#)
Demisting the rear window, [287](#)
Detection of pedestrians, [195](#)

Detection of road signs, [204](#)
Detection of vehicles, [195](#)
Display, [107](#), [111](#)
Doors, [38](#), [38](#), [42](#)
Doors/luggage compartment door, [32](#), [39](#), [42](#)
Driver assistance, [167](#), [172](#), [186](#), [192](#), [195](#), [204](#), [261](#), [266](#)
Driver vigilance warning, [202](#)
Driving, [143](#), [148](#), [153](#), [157](#), [164](#), [167](#), [172](#), [186](#), [192](#), [195](#),
[226](#), [230](#), [234](#), [261](#), [266](#)
Driving advice, [157](#), [157](#)
Driving aids, [112](#), [172](#), [186](#), [192](#), [195](#), [204](#), [209](#), [234](#), [261](#), [266](#),
[273](#), [277](#)
Driving position, [95](#)
Driving position settings, [55](#), [120](#)

E

ECO driving, [157](#), [157](#)
ECO mode, [157](#)
Electric windows, [295](#)
Electronic parking brake, [150](#), [153](#)
Electronic stability program: ESC, [167](#)
Emergency brake assist, [167](#)
Emergency braking, [167](#), [195](#)
Emergency lane departure prevention, [179](#)
Emergency spare wheel, [328](#)
Emission control advice, [156](#), [156](#)
Engine coolant, [111](#)
Engine identification, [356](#)

ALPHABETICAL INDEX

Engine oil, [309](#), [309](#), [310](#)
Engine oil capacities, [310](#)
Engine oil dipstick, [309](#)
Engine oil level, [111](#), [309](#), [309](#), [310](#)
Engine specifications, [356](#)
Environment, [154](#)
ESC: Electronic stability program, [167](#)
Excessive speed warning, [204](#)
Exterior lighting and signals, [124](#)
Exterior temperature, [114](#)

F

Filling with fuel, [137](#)
Filter: oil, [310](#)
Fitting a child seat, [74](#)
Fittings, [301](#)
Front headlights, [338](#)
Front headrests, [49](#)
Front seat adjustment, [49](#)
Front seat belt pretensioners, [60](#)
Front seats, [49](#)
Fuel consumption, [100](#), [157](#), [157](#)
Fuel economy, [157](#)
Fuel grade, [137](#)
Fuel level, [111](#), [137](#)
Fuel range, [111](#)
Fuel tank cap, [137](#)
Fuel tank capacity, [137](#)

Fuel tips for reducing consumption, [157](#)
Fuses, [344](#), [344](#)

G

Gear control, [143](#)

H

Hands-free card, [32](#)
Hazard signal, [130](#)
Headlights changing bulbs, [338](#)
Headrests, [49](#)
Heated steering wheel, [120](#)
Heated windscreen, [287](#)
Heating: air outlets: vents, [285](#)
Heating and air conditioning system, [285](#), [287](#)
Heating system, [285](#), [287](#)
Hill start assistance, [167](#)
Horn, [130](#)

I

Incidents: operating faults, [172](#), [186](#), [195](#)
Indicators, [130](#), [338](#)
Indicators: direction indicators, [130](#)
Instrument panel, [100](#), [111](#), [112](#), [157](#), [164](#)
Instrument panel warning lights, [100](#), [111](#), [157](#), [164](#)
Interior lighting, [297](#)
Interior trim maintenance, [319](#)
Isofix, [80](#), [88](#)

ALPHABETICAL INDEX

J

Jack, [330](#)

L

Labels: tyre pressure, [323](#)

Lane Centring, [209](#)

Lane departure prevention, [172](#)

Lane departure warning, [172](#)

Lane keeping: assistance, [172](#)

Lane Keeping Assist, [172](#)

Levels, [308](#), [314](#)

Levels: coolant, [312](#)

Lifting the vehicle Changing a wheel, [330](#)

Light call, [130](#)

Lighting: instrument panel, [124](#)

Lighting: see-me-home lighting, [124](#)

Lighting signals, [124](#), [130](#)

Lights: dipped beam headlights, [124](#), [338](#)

Lights: direction indicator lights, [130](#), [338](#)

Lights: exterior, [124](#), [130](#)

Lights: fog lights, [124](#)

Lights: hazard warning lights, [130](#)

Lights: main beam headlights, [124](#)

Lights: side lights, [124](#), [338](#)

Lights-on reminder audible alarm, [124](#)

Locking, [55](#)

Locking/unlocking the doors, [39](#)

Locking the doors, [32](#), [38](#), [39](#), [42](#)

LPG, [68](#)

Luggage compartment, [43](#), [43](#)

M

Maintenance, [156](#)

Maintenance: bodywork, [317](#)

Maintenance: filters, [314](#)

Maintenance: interior trims, [319](#)

Maintenance: mechanical, [308](#), [309](#)

Maintenance: mileage before oil change, [100](#)

Messages on the instrument panel, [100](#), [164](#)

Methods of restraint in addition to the front seat belts, [60](#)

Mileage before oil change, [100](#)

Multifunction screen, [186](#)

Multimedia equipment, [111](#), [124](#), [293](#)

Multimedia screen, [172](#), [192](#), [195](#)

Multimedia screen screens, [157](#), [261](#), [266](#), [273](#), [287](#)

MULTI-SENSE, [283](#)

Multi-view camera, [266](#)

O

Oil change, [310](#)

Opening elements, [32](#), [38](#), [42](#)

Opening the doors, [38](#), [38](#), [39](#)

Operating faults, [60](#), [92](#), [100](#), [124](#), [148](#), [148](#), [167](#), [167](#), [172](#), [186](#), [195](#), [234](#), [273](#), [344](#), [344](#)

Operating faults: card batteries, [30](#)

Operating faults card batteries, [35](#)

ALPHABETICAL INDEX

P

Paintwork: maintenance, [317](#)
Park Assist: assisted parking, [261](#)
Parking: park assist, [273](#)
Parking brake, [150](#), [153](#)
Parking distance control, [112](#), [252](#), [258](#)
Passenger safety: front passenger airbag, [92](#)
Power-assisted steering, [120](#), [120](#)
Power consumption, [107](#)
Pretensioners, [60](#)
Puncture, [326](#), [328](#), [330](#)
Puncture: emergency spare wheel, [328](#)

R

Rear bench seat, [53](#)
Rear headrests, [52](#)
Rear parcel shelf, [304](#)
Rear seats, [52](#)
Rear seats Functions, [53](#)
Rear shelf, [304](#)
Rear view mirrors, [120](#), [122](#), [122](#)
Remote control, [32](#)
Replacement and repair parts, [361](#)
Replacement bulbs, [338](#)
Replacing windscreen wiper blades, [342](#)
Restraint devices in addition to the rear seat belts, [65](#)
Restraint in addition to the seatbelts, [60](#), [65](#), [65](#)
Reversing camera, [258](#), [258](#)

Roof bars, [307](#)

S

Safe distance, [234](#)
Safe distance alert, [192](#)
Safe distances, [192](#)
Safe passenger exit, [277](#)
Safe vehicle exit, [277](#)
Seat belts, [55](#), [55](#), [55](#), [60](#), [76](#), [80](#), [88](#), [319](#)
Seat belts: adjusting the seat belt height, [55](#)
Seat belts: adjustment of driving position, [55](#)
Seat belts: seat belt adjustment, [55](#)
Seat belts: seat belt reminder warning light, [55](#)
Settings, [112](#)
Side protection devices, [65](#), [65](#)
Special features of petrol vehicles, [148](#)
Speed limiter, [226](#)
Starting the engine, [140](#)
Steering wheel adjustment, [120](#)
Stop and Start, [120](#), [137](#)
Stopping the engine, [140](#)
Storage compartment, [301](#)
Storage compartment/ fittings: passenger compartment, [301](#)
Storage compartments, [301](#)

T

Temperature regulation, [287](#)
Time setting, [100](#)

ALPHABETICAL INDEX

Towing rings, [332](#)
Traction control, [167](#)
Traction control: ASR, [167](#)
Transporting children, [68](#), [76](#), [80](#), [88](#)
Transporting objects in the luggage compartment, [305](#)
Trip computer, [100](#), [100](#), [111](#)
Troubleshooting: battery, [334](#)
Tyre inflation, [164](#), [326](#), [330](#)
Tyre inflation kit, [164](#), [326](#)
Tyre pressure, [100](#), [157](#), [164](#), [330](#)
Tyre pressure loss warning, [163](#), [164](#), [330](#)
Tyres, [157](#), [164](#), [321](#), [321](#)
Tyres: inflation pressure, [323](#)

U

Unlocking the doors, [32](#), [39](#)
User precautions, [131](#), [131](#)

V

Variable power assisted steering, [120](#)
Vehicle customisation settings, [112](#)
Vehicle settings personalisation menu, [100](#), [112](#)
Ventilation, [287](#)

W

Warning, [130](#)
Warning: parking exit, [272](#)
Warning lights, [186](#)

Washing, [317](#)
Wheelbrace, [330](#)
Wheels (safety), [321](#)
Windscreen demisting, [287](#)
Windscreen washer, [131](#), [131](#), [134](#)
Wiper, [131](#), [131](#), [131](#), [134](#)
Wiper blades: replacement, [342](#)



RENAULT S.A.S. SOCIÉTÉ PAR ACTIONS SIMPLIFIÉE / 122-122 BIS, AVENUE DU GENERAL LECLERC 92100 BOULOGNE-BILLANCOURT R.C.S. NANTERRE 780 129 987 — SIRET 780 129 987 03591 / renaultgroup.com

NU 1539-2 - 77 11 417 091 - 09/2024 - Edition anglaise



7711417091

