

ARKANA MEGANE CONQUEST

vehicle user manual





Welcome aboard your vehicle

This user manual contains the information required:

- for you to familiarise yourself with your vehicle, to use it to its best advantage and to fully benefit from all the functions and the technical developments it incorporates.
- to ensure that it always gives the best performance by following the simple, but comprehensive advice concerning regular maintenance.
- to enable you to deal quickly with minor faults not requiring specialist attention.

It is well worth taking a few minutes to read this manual to familiarise yourself with the information and guidelines it contains about the vehicle and its functions and new features. If certain points are still unclear, our Network technicians will be only too pleased to provide you with any additional information.

For guidance, please see the following symbols:

 and  Visible on the vehicle, they show that you should consult the manual to find detailed information and/or limits on operations in respect of equipment on your vehicle.

→ anywhere in the manual indicates a transfer to a page.



anywhere in the manual indicates a hazard, danger or a safety recommendation.

The description of the models given in this manual is based on the technical specifications at the time of writing. **The manual covers all items of equipment (both standard and optional) available for these models, but whether or not these are fitted to the vehicle depends on the version, the options selected and the country where the vehicle is sold.**

This manual may also contain information about items of equipment to be introduced later in the model year.

The diagrams in the user manual are provided as examples only.

Enjoy driving your new vehicle.

Translated from French. Copying or translation, in part or in full, is forbidden unless prior written permission has been obtained from the car manufacturer.

CONTENTS

Welcome to your new vehicle	4	Driving	127
Exterior.....	4	Running in.....	127
Passenger compartment.....	6	Starting, stopping the engine.....	128
Driver's position.....	8	Gear control.....	135
Driving aids.....	10	Special features of petrol versions	144
Safety on board.....	12	Parking brake	146
Identifying a vehicle - labels.....	14	Driving advice, eco driving.....	151
The engine compartment (routine maintenance).....	16	Environment.....	157
Breakdown recovery.....	18	Maintenance and antipollution advice	158
The E-Tech full hybrid vehicle.....	20	Tyre pressure loss warning	159
Getting to know your vehicle	22	Driving correction devices and aids.....	162
E-tech full hybrid vehicle (HEV).....	22	Additional driving aid functions.....	165
Card.....	29	Speed limiter	202
Doors and opening elements.....	38	Cruise control	205
Front seats.....	44	Stop and Go adaptive cruise control.....	208
Rear seats.....	48	Parking aids	221
Seat belts	50	Emergency call.....	246
Additional safety devices	54	Your comfort	249
Child safety.....	62	Multi-sense.....	249
Child seats.....	68	Air vents, heating and air conditioning.....	251
Child safety: deactivating, activating the front passenger airbag	78	Multimedia equipment.....	261
Driving position.....	81	Passenger compartment equipment.....	264
Warning lights	85	Passenger compartment storage, fittings	272
Trip computer	91	Transporting objects	276
Steering.....	109	Maintenance	280
Rear view	111	Accessing the engine, levels	280
Lighting and signals.....	113	Battery	289
Audible and visual signals.....	119	Cleaning.....	293
Wiper	120	Practical advice.....	297
Fuel tank.....	124	Tyres.....	297

CONTENTS

Breakdown recovery	309
Headlights, lights: replacing bulbs	316
Wiper blades: replacement.....	322
Fuses	324
Installation and use of accessories	326
Operating faults.....	328
Technical specifications.....	333
Information about the vehicle.....	333
Replacement parts and repairs	339
Service sheets	340
Anticorrosion check	346

EXTERIOR

1

56496

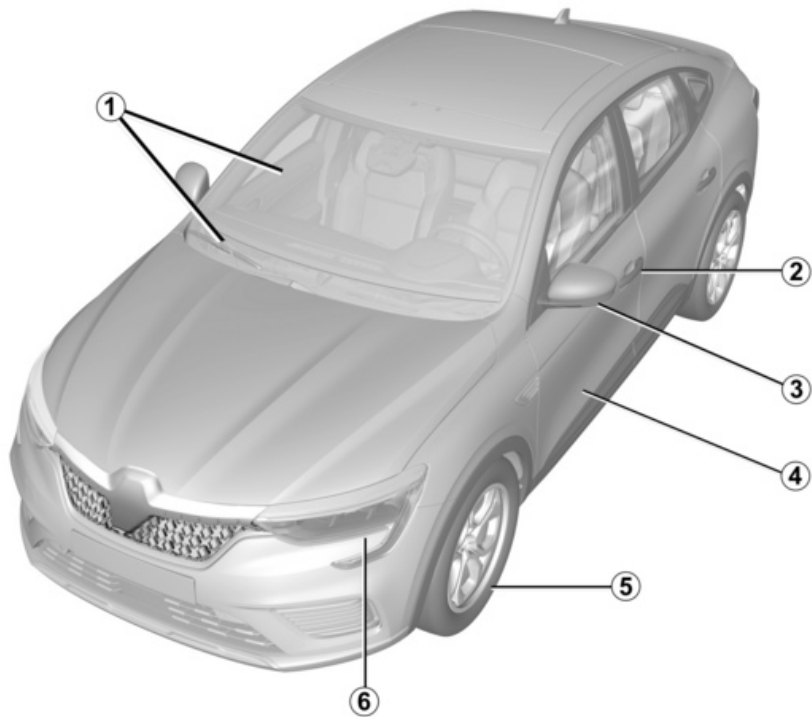

EXTERIOR

1 Electric windows → **264**

Windscreen wipers → **120**

Demisting → **253** or → **255**

2 Card → **29**

Locking/unlocking the doors → **39**

3 Rear view mirrors → **111**

4 Bodywork maintenance → **293**

5 Tires → **297**

6 Lights: operation → **113**

Lights: replacement → **316**

PASSENGER COMPARTMENT

1

526319

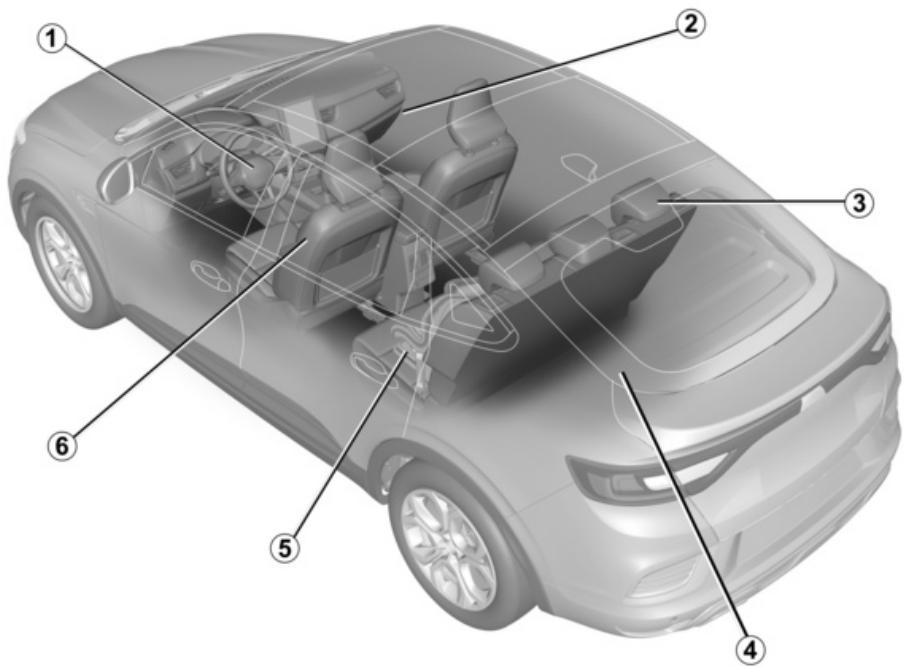

PASSENGER COMPARTMENT

1 Adjusting your driving position →
50

2 Passenger compartment storage/
fittings → **272**

3 Rear bench seat → **49**

Rear headrests → **48**

4 Luggage compartment storage/
fittings → **43**

5 Child safety → **62**

6 Front seats → **44**

Front headrests → **44**

DRIVER'S POSITION

1

52635

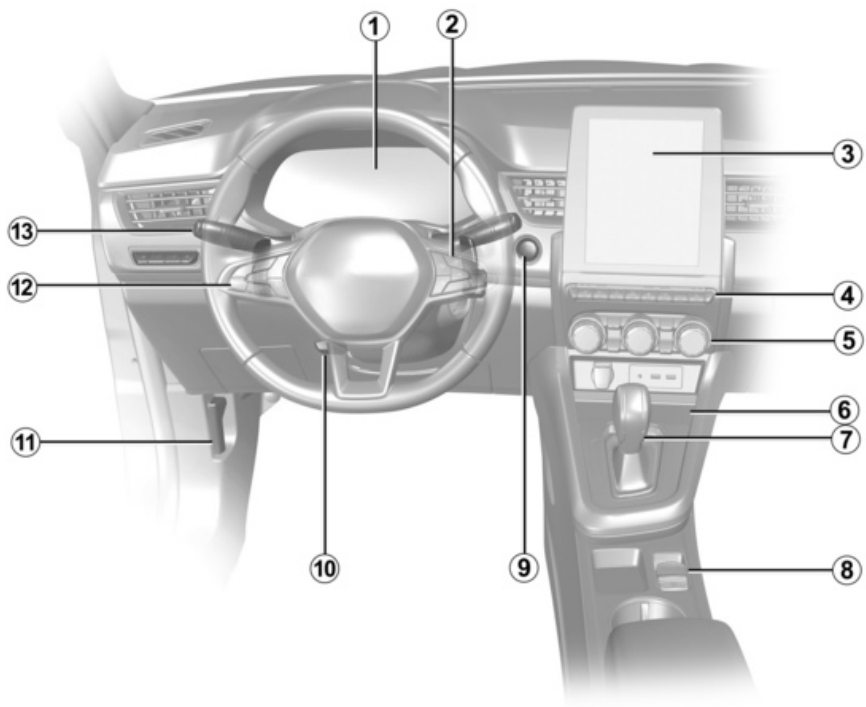

DRIVER'S POSITION

- 1** Instrument panel → **85**
- 2** Trip computer controls → **91**
- 3** Multimedia screen → **261**
- 4** Heated seats → **44**
- 5** Heating/Air conditioning system
→ **253** or → **255**
- 6** Telephone charging zone → **272**
- 7** Gearstick → **135**
- 8** Parking brake → **146**
- 9** Engine start/stop button → **128**
- 10** Steering wheel adjustment → **109**
- 11** Bonnet release → **280**
- 12** Speed limiter → **202**
- Cruise control → **205**
- Stop and Go adaptive cruise control
→ **208**
- 13** Exterior lighting → **113**

DRIVING AIDS

1

46690

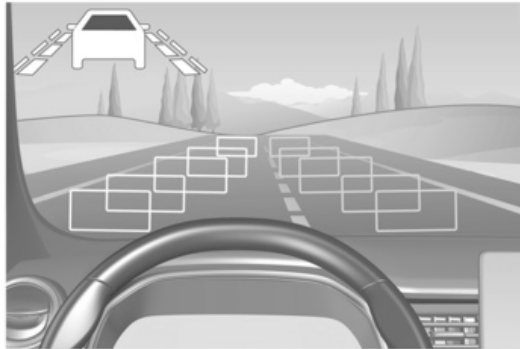

DRIVING AIDS

- ABS (anti-lock braking system)
→ **162**
- ESC (electronic stability control)
→ **163**
- Hill start assistance → **164**
- AUTOHOLD → **149**
- Lane departure prevention → **166**
- Active emergency braking → **178**
- Blind spot warning → **171**
- Stop and Start → **131**
- Safe distance alert → **175**
- Speed limiter → **202**
- Detection of road signs → **186**
- Cruise control → **205**
- Stop and Go adaptive cruise control → **208**
- Active Driver Assist → **190**
- Parking distance control → **221**
- Reversing camera → **226**
- 360° camera → **234**
- Parking exit warning → **242**
- Assisted parking → **229**
- Tyre pressure loss warning → **159**

SAFETY ON BOARD

1

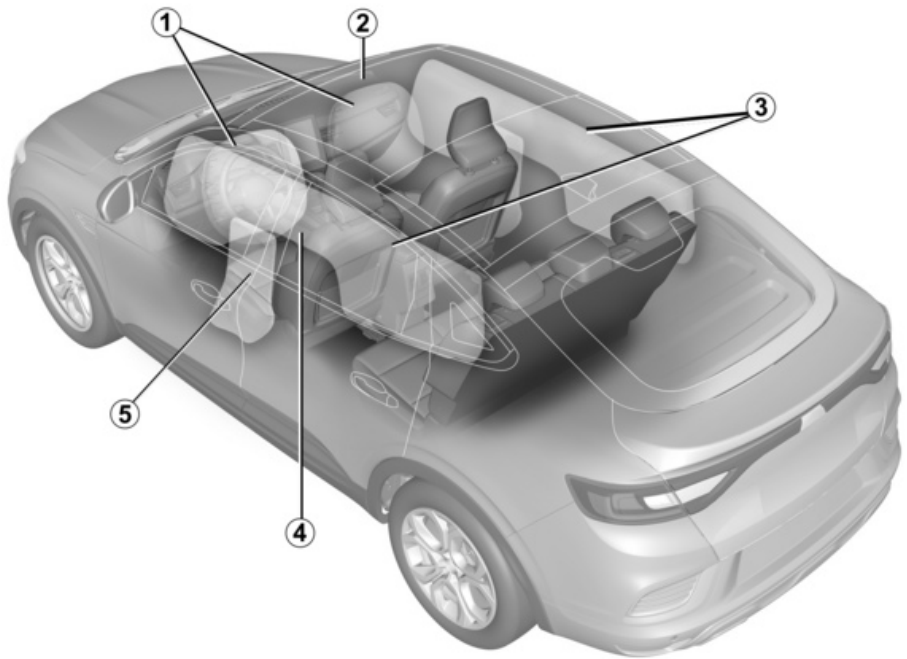

526140

SAFETY ON BOARD

1 Front Airbags → **54**

2 Inhibiting the front passenger
airbag → **78**

3 Curtain Airbags → **59**

4 Seat belts → **50**

5 Side Airbags → **59**

IDENTIFYING A VEHICLE - LABELS

1

56487

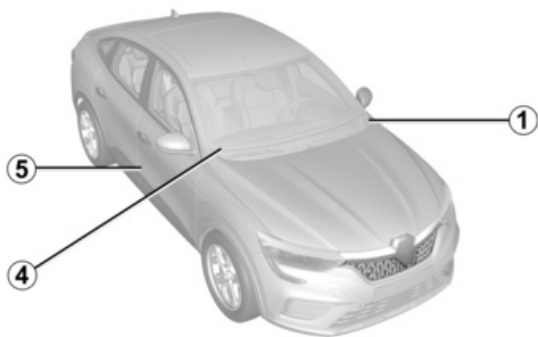

IDENTIFYING A VEHICLE - LABELS

1 Review of a vehicle identification number → **333**

2 Tyre pressure labels → **159** and → **299**

3 Engine identification plate → **334**

4 Technical information for the emergency services → **333**

5 Vehicle identification plate → **333**

THE ENGINE COMPARTMENT (ROUTINE MAINTENANCE)

1

596530

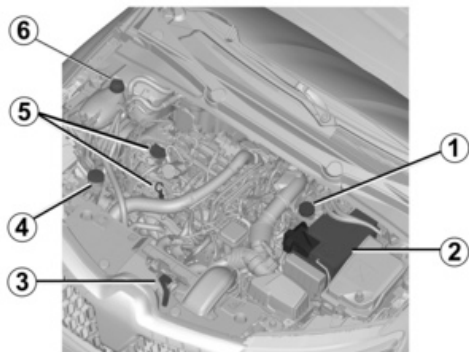

THE ENGINE COMPARTMENT (ROUTINE MAINTENANCE)

1 Brake fluid → **286**

2 12V battery → **289**

3 Opening the bonnet → **280**

4 Windscreen washer fluid → **287**

5 Engine oil filler cap → **282**

Engine oil dipstick → **281**

6 Coolant level → **285**

BREAKDOWN RECOVERY

1

56734

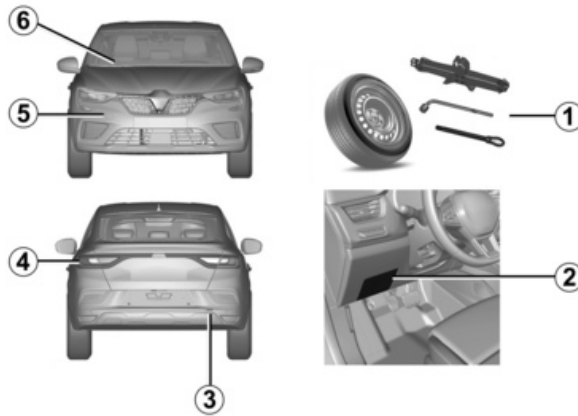

BREAKDOWN RECOVERY

1 Puncture:

Tools → **303**

Emergency spare wheel → **304**

Changing a wheel → **306**

2 Fuses → **324**

3 Rear towing point → **309**

4 Replacement of the direction indicator lights → **316**

5 Front towing point → **309**

6 Replacing windscreen wiper blade(s) → **322**

THE E-TECH FULL HYBRID VEHICLE

1

56732

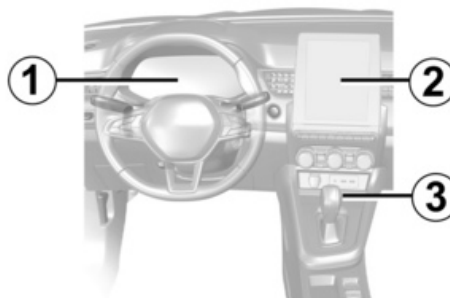
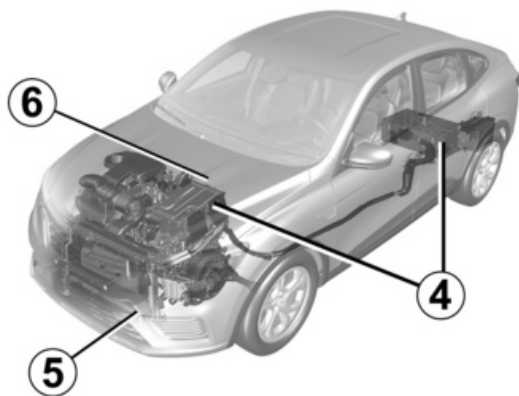

THE E-TECH FULL HYBRID VEHICLE

E-Tech full hybrid vehicle system: introduction → **22**

E-Tech full hybrid vehicle system: important recommendations → **28**

1 Warning lights → **85**

Displays and indicators → **100**

Charge meter → **154**

2 Multimedia screen

3 Driving in mode **B** → **136** or → **141**

4 Batteries → **23**

5 Towing, breakdown recovery
→ **309**

6 Electric traction system coolant
→ **285**

E-TECH FULL HYBRID VEHICLE (HEV)

Introduction

2

54280

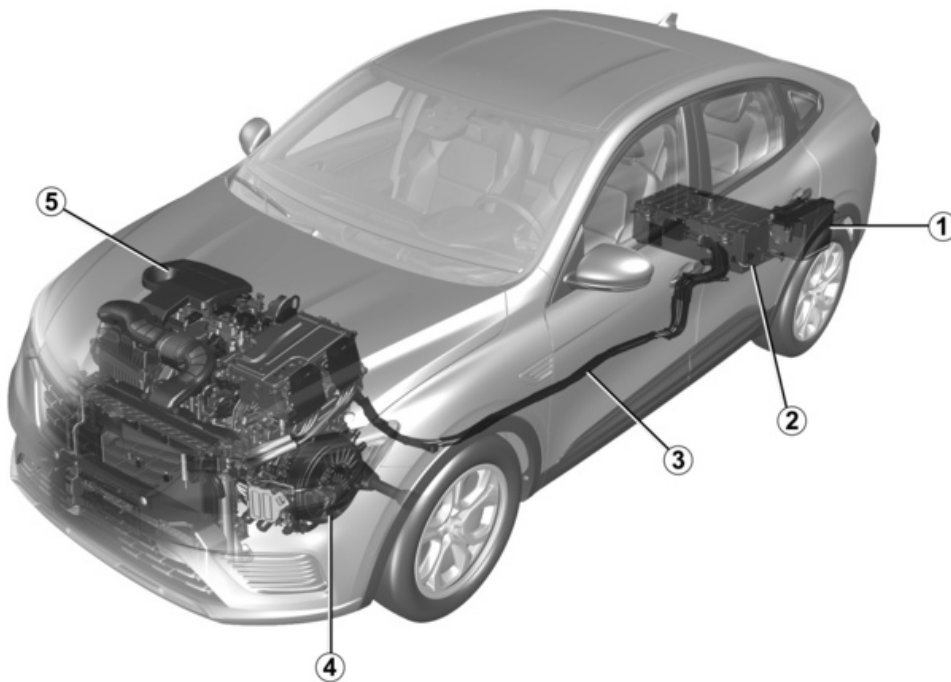

E-TECH FULL HYBRID VEHICLE (HEV)

1 Secondary '12V' battery

2 '230 volt' traction battery

3 Orange electrical power cables

4 Electric motor

5 Combustion engine

The hybrid vehicle system uses an electric motor to improve the performance of the combustion engine (acceleration, starting etc.).

The vehicle has more acceleration torque available while consuming less fuel.

The vehicle may also move in all-electric operating mode without any assistance from the combustion engine. The vehicle uses energy stored in the "230 V" traction battery.

Batteries

The hybrid vehicle is equipped with two types of battery :

- a 230 V traction battery ;
- a secondary "12 V" battery.

"230 volt" traction battery

This battery, located underneath the rear floor, stores the energy required for the electric motor to operate correctly.

As with any battery, it discharges when it is used. The traction battery is charged :

- during the vehicle deceleration phases ;
- when the combustion engine starts automatically in order to act as a generator.

Your vehicle range in electric operating mode depends on the charge level of the traction battery, and also on your driving style and the components consuming energy (air conditioning, heating system etc.).

In the event of traction battery discharge, the combustion engine alone moves the vehicle until the traction battery is sufficiently recharged.

If your vehicle is parked for a long time, start the engine at regular intervals (about once a month) and

check that the warning light  is displayed in blue on the instrument panel.

If this happens, the battery needs to be recharged: leave the engine on until the warning light is displayed in blue. ➔100

Failure to do so may result in damage to the traction battery and make it impossible to start the vehicle.

The vehicle's air conditioning system is used to cool the traction battery.

To preserve the lifetime of your traction battery, have your air conditioning system checked by a qualified professional. Especially if you notice a reduction in air conditioning performance.

Secondary "12 V" battery

The secondary "12 V" battery, located in the luggage compartment, supplies the energy required to open/close the vehicle and to operate the equipment.

Note : the secondary battery "12 Volts" does not participate when the engine is started. This is ensured by the hybrid system.

E-TECH FULL HYBRID VEHICLE (HEV)

2



The electrical system of the hybrid vehicle uses direct voltage of approximately 230 V.

This system can get hot during and after switching off the ignition. Respect warning messages given on the labels in the vehicle.

All operations on or modifications to the "230 V" electrical system (components, cables, connectors, traction battery) are strictly prohibited due to the risks they present to your safety. Call an approved Dealer.

The risk of serious burns or electric shocks can lead to death.

A

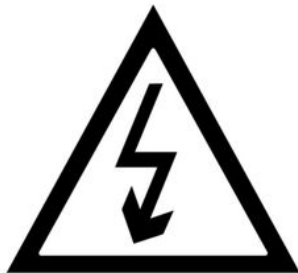

The **A** symbol denotes the electrical elements of your vehicle which may present health risks.

33436

"230 volt" electrical circuit

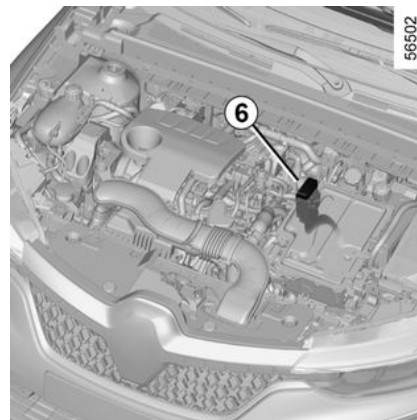

56502

The 230 V electrical circuit is denoted by orange cables **6** and parts

bearing the  symbol.

Noise

The hybrid vehicles are particularly quiet in electric operating mode.

You will not yet necessarily be used to it, and neither will other road users. It is difficult for them to hear your vehicle when it is moving.

To warn people of your vehicle presence, your vehicle is fitted with a pedestrian horn. In electric operating mode, the system is activated automatically. The sound is trig-

E-TECH FULL HYBRID VEHICLE (HEV)

gered when the vehicle speed is between about 1 and 19 mph (1 and 30 km/h).

As the electric motor is silent, you will hear noises that may seem unusual (aerodynamic noises, tyres etc.) as well as noises due to the operation of the hybrid system (e.g. cooling of the traction battery).



Your hybrid vehicle is very quiet. When getting out of the vehicle, always check that the gear selector is in P position, apply the parking brake and switch off the ignition.

RISK OF SERIOUS INJURY.

Operation

The hybrid system selects the combustion engine and/or the electric motor according to the driving style (smooth, sporty etc.), the traffic conditions and driving mode selected.

→ 249

Bad weather, flooded roads :



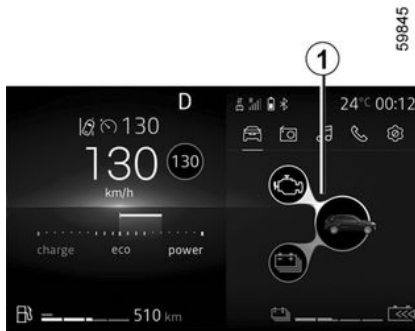

Do not drive through floods if the depth of water is above the lower edge of the wheel rims.

Energy flow indicator 1



59845

Depending on the driving mode selected, the **1** indicator represents the energy flows between :

-  the electrical assembly (traction battery and electric motor) ;
-  the combustion engine.

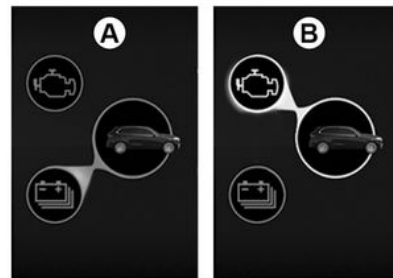

59844

2

The colour of the flows varies :

- blue : electrical energy ;
- white : energy produced by the combustion engine.

Flow A "Electric traction"

The electrical assembly is used to power movement of the vehicle.

Flow B "Combustion engine traction"

The combustion engine is used to power movement of the vehicle.

E-TECH FULL HYBRID VEHICLE (HEV)

2

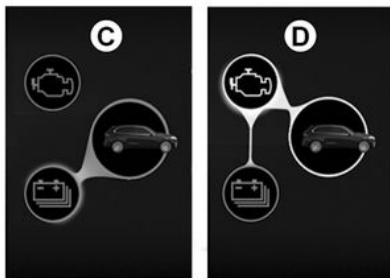

Flow C "Energy recovery"

When you lift your foot off the accelerator pedal or press the brake pedal, the electric motor and/or regenerative braking system converts the energy produced through deceleration of the vehicle into electrical energy.

This is used to slow down the vehicle and recharge the traction battery.

Flow D "Energy production"

The combustion engine recharges the traction battery.

Note : a combination of different flows is possible (e.g. associating the **A** flow with the **B** flow means that both the combustion engine and

electric motor are powering movement of the vehicle).



Special case

When the traction battery reaches a maximum charge level, the engine brake is temporarily reduced. Please adapt your driving style appropriately.



The engine brake should under no circumstances be used as a substitute for the brake pedal.

All-electric driving mode



The **2 EV** warning light is displayed on the instrument panel to inform you that the hybrid system is using only the electrical assembly to power the vehicle movement.

Note : EV mode can be activated only in My Sense or ECO mode.

E-TECH FULL HYBRID VEHICLE (HEV)



When the hybrid system is using the combustion engine with or without the electric motor to power the vehicle movement, it is possible to manually switch to all electric mode.

This mode can be accessed if :

- the traction battery is sufficiently charged ;
- the vehicle speed is below approximately 30 mph (50 km/h).

Press the switch **3**.

The warning light on switch **3** is on

and the **2 EV** warning light is displayed on the instrument panel.

Otherwise, the message "EV unavailable" is displayed on the instrument panel.

Press again on the **3** switch to deactivate all-electric mode. The **3** switch warning light goes out. The **2**

EV warning light is no longer displayed on the instrument panel when the vehicle switches to hybrid mode and the combustion engine starts.

Note : when the traction battery level is low, the vehicle automatically switches to hybrid mode and the combustion engine starts : the **2**

EV warning light disappears from the instrument panel and the warning light on switch **3** goes out to confirm this.

E-TECH FULL HYBRID VEHICLE (HEV)

Important recommendations

2



Please read these instructions carefully. Failure to follow these instructions may lead to a **risk of fire, serious injury or electric shock which may present a risk to life.**

In the event of an accident or impact

In the event of an accident or an impact to the underside of the vehicle (e.g. striking a post, raised kerb or other street furniture) the electric circuit or the traction battery may be damaged.

Have the vehicle checked by an authorised dealer.

Never touch the "230 volt" components or orange cables which are exposed and visible inside or outside the vehicle.

In the event of serious damage to the traction battery, leaks may occur :

- never touch the liquids (fluids, etc.) coming from the traction battery ;
- in the event of contact with the body, wash the affected area with plenty of water and consult a doctor as soon as possible.

In the event of fire

In the event of a fire, leave the vehicle immediately and evacuate it, then contact the emergency services, informing them that this is a hybrid vehicle.

Only use extinguishing agents ABC or BC that are permitted for use with electrical fires. Do not use water or other extinguishing agents.

In the event of damage to the electrical circuit, please call an authorised dealer.

All towing operations

Refer to the paragraph entitled "Towing, breakdown". → 309

Washing the vehicle

Never wash the engine compartment and "230 V" traction battery using a high-pressure jet.

This risks damaging the electric circuit.

Risk of electric shock and a risk to life.

CARD

General information

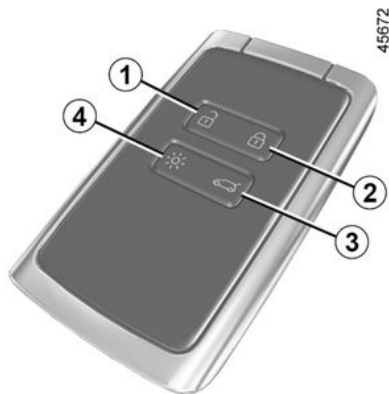

- 1 Unlocking the doors and tailgate.
- 2 Locking all doors and tailgate.
- 3 Unlocking/locking the boot.
- 4 Switching-on the lighting remotely.

The card is used for:

- locking/unlocking the doors and tailgate (doors, tailgate) and the fuel filler flap;
- switching on the vehicle lighting remotely;
- automatic remote closing of the electric windows → 264.

Battery life

Make sure that the correct battery type is being used, and that the battery is in good condition and inserted correctly. Its service life is approximately two years: it should be replaced when the message "Key-card Battery Low" appears on the instrument panel → 35.



When the battery is flat, you can still lock/unlock and start your vehicle

→ 39 and → 128.

Card operating range

This varies according to the environment: take care not to accidentally lock or unlock the vehicle by inadvertently pressing the buttons on the card.

Note: if a door or the boot is open or not properly shut, locking is not carried out. A beep sounds and the hazard warning lights and side repeaters do not flash.

Distance lighting function



Pressing button 4 switches on the dipped beam headlights and the exterior lighting for approximately 20 seconds. This can be used, for example, to identify the vehicle from a distance when parked in a car park.

Pressing and holding the 4 button for approximately two seconds activates the exterior lighting and a sound is emitted.

Note: pressing button 4 again switches off the lighting.

CARD



Advice

Avoid leaving the card in hot, cold or humid areas.

Do not keep the card in a place where it could be bent or damaged accidentally, such as in a back pocket of a garment.



Replacement : need for an additional card

If you lose your card or require another, you can obtain one from an authorised dealer. If a card is replaced, it will be necessary to take the vehicle **and all its cards** to an approved Dealer to initialise the system. You may use up to four cards per vehicle.

Interference

Interference by factors in the immediate vicinity (external installations or the use of equipment operating on the same frequency as the card) may disrupt its operation.



Driver's responsibility when parking or stopping the vehicle

Never leave an animal, child or adult who is not self-sufficient alone in your vehicle, even for a short time.

They may pose a risk to themselves or to others by starting the engine, activating equipment such as the electric windows or locking the doors, for example.

Also, in hot and/or sunny weather, please remember that the temperature inside the passenger compartment increases very quickly.

RISK OF DEATH OR SERIOUS INJURY.

Fitting a strap 7



Slide the rear casing **5** downwards while pressing on zone **A**.

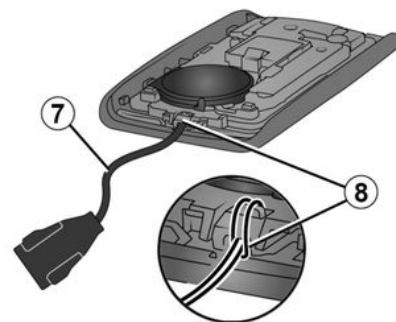

CARD

Insert the hand strap into the **8** component and pass the end of the strap through the buckle.

Position the strap at the **6** opening and close the cartridge.

Note : check that the diameter of the strap cord **7** will fit the opening **6**.

Use

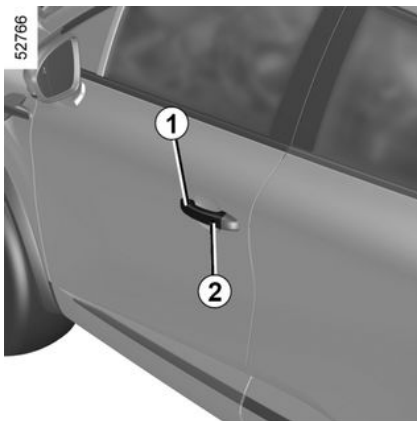

There are three ways to unlock/lock the vehicle :

- "hands-free", when approaching and moving away from the vehicle ;
- depending on the vehicle, "hands-free", using the **2** button on the **7** handle of one of the front doors ;
- using the card in remote control mode.

Deactivating/activating the « hands-free » mode

Depending on the vehicle, you can deactivate/activate :

- unlocking when approaching and locking when moving away from the vehicle ;
- locking and unlocking by pressing on the buttons on the door handle.

You can also disable/activate the sound signal that is emitted upon locking when moving away from the vehicle. → **105**



Do not store the card anywhere it may come into contact with other electronic equipment (computer, phone etc.) as this could hinder its operation.



Never leave your vehicle with the card inside.



Driver's responsibility when parking or stopping the vehicle

Never leave an animal, child or adult who is not self-sufficient alone in your vehicle, even for a short time.

They may pose a risk to themselves or to others by starting the engine, activating equipment such as the electric windows or locking the doors, for example.

Also, in hot and/or sunny weather, please remember that the temperature inside the passenger compartment increases very quickly.

RISK OF DEATH OR SERIOUS INJURY.

CARD

Hands-free unlocking, when approaching the vehicle ;

2



52343

With the card in access zone **3**, the vehicle will unlock. Unlocking is indicated by **one flash** of the hazard warning lights and the indicator lights.



Depending on the vehicle, the door mirrors fold in/out automatically when the vehicle is locked/unlocked.

➔ 111

Hands-free locking when moving away from the vehicle



52344

With the card on you, doors and luggage compartment door closed, move away from the vehicle : it will lock automatically once you have left the access zone **3**.

Note : the distance at which the vehicle locks depends on the surroundings.

To indicate that the vehicle has been locked, the hazard warning lights **flash twice and then light up** for approximately four seconds, and a beep sounds in confirmation.



45672

If the card has been within the detection area **3** for approximately 15 minutes, remote locking is disabled. To lock the vehicle, press the **2** button on the **1** handle depending on the vehicle or the **5** button on the card.

The vehicle cannot be locked with hands-free locking if the card is within the area **4**.

CARD

“Hands-free” unlocking/locking using button 2

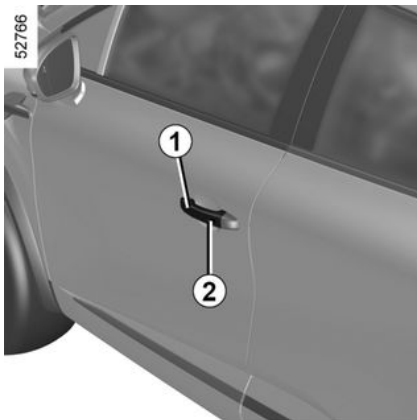

With the card in zone **3** and the vehicle locked, press the button **2** on the handle **1** of one of the two front doors depending on the vehicle : the vehicle unlocks. Press the button **2** also unlocks all the doors and the tailgate.

The hazard lights and side repeaters **flash once** to indicate that the doors have unlocked and, on some vehicles, the door mirrors fold out automatically.

Pressing the **2** button again locks the vehicle.

The hazard warning lights **flash twice** to indicate that the vehicle is

locked and, depending on the vehicle, the door mirrors automatically fold in.

Special features of the unlocking system

In certain circumstances, approach unlocking is disabled :

- after eight days of non-use of the vehicle ;
- if the card remains near zone 3 of the vehicle for approximately five minutes after locking the vehicle ;
- after several passages near zone 3 of the vehicle and without the doors having been unlocked.

Press button **2** (front door handle) or use the remote control card you to unlock the vehicle and reactivate hands-free mode.

Special features relating to hands-free locking



After locking in “hands-free” mode, you have to wait approximately three seconds before being able to unlock the vehicle again. During these three seconds, the door handles can be tried to make sure that the vehicle is locked properly.

Note : if a door or the boot is open or not properly shut, locking is not carried out. A beep sounds and the hazard warning lights and side repeaters do not flash.

CARD

Using the card as a remote control

2

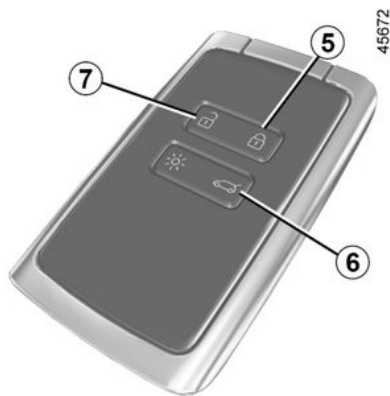

Unlocking with the card

Press button **7**.

The hazard lights and side repeaters **flash once** to indicate that the doors have unlocked and, on some vehicles, the door mirrors fold out automatically.



The card buttons are deactivated when the engine is running.

Locking using the card

With the doors and boot closed, press button **5** : the vehicle locks.

The hazard warning lights **flash twice** to indicate that the vehicle is locked and, depending on the vehicle, the door mirrors automatically fold in.

Pressing the **5** button twice locks the vehicle and enables the closure of the front and rear windows (depending on the vehicle).

Note :

- the maximum distance at which the vehicle locks depends on the surroundings ;
- if a door or the boot is open or not properly shut, locking is not carried out. A beep sounds and the hazard warning lights and side repeaters do not flash.



If, **while the engine is running**, a door is opened and closed, and the card is no longer in the zone **4**, the message "Keycard Not Detected" indicates that the card is not inside the vehicle. This will, for example, prevent you from driving away after dropping off a passenger who has kept the card on them.

The warning disappears when the card is detected again.

Locking/unlocking only the boot

Press the button **6** to lock/unlock the boot only.

CARD

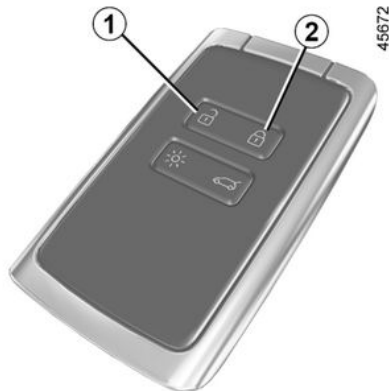

Never use deadlocking if someone is still inside the vehicle.

If the vehicle is equipped with a deadlocking function, this allows you to lock the opening elements and to prevent the doors from being unlocked using the interior handles (for example, by breaking the window and then trying to open the door from the inside).

To activate deadlocking

To do this, press button **2** twice in quick succession.

Locking is confirmed by **two slow flashes and three quick flashes** of the hazard warning lights and indicator lights.

Special note: deadlocking is not possible if the hazard warning lights or the side lights are lit.



Depending on the vehicle, the door mirrors fold in automatically when the vehicle is locked. → III

To deactivate deadlocking

Unlock the vehicle using button **1** on the card.

Unlocking is indicated by **one flash** of the hazard warning lights and indicator lights.

Hands-free card: battery

Replacing the battery



When the message "Keycard Battery Low" appears on the instrument panel, replace the battery in the card:

- slide the rear casing **1** downwards while pressing on zone **A** ;
- remove the battery cover **2** ;
- remove the battery by pressing on one side and lifting the other ;
- replace it according to the direction and template shown inside the cover.

CARD

43532

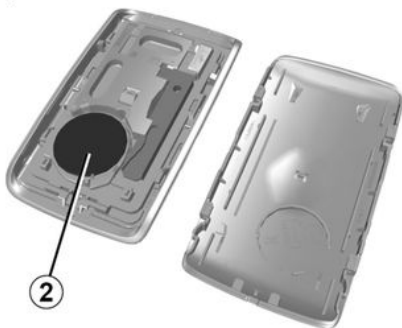



When refitting, proceed in the reverse order, then press one of the buttons on the card four times, close to the vehicle : the next time the vehicle is started, the message will disappear.

Check that the cover is clipped shut.

Note : do not touch the electronic circuit or contacts on the card when replacing the battery.

 The batteries are available from approved Dealers, and their service life approximately two years. Check that there is no dye on the battery : risk of an incorrect electrical contact.

 If they need to be replaced, be sure to use the same or equivalent type of battery (consult an Approved Dealer).

 When replacing :

- make sure that the batteries are correctly inserted.

Risk of explosion.

- if the flap does not close correctly, do not use and keep out of reach of children.

Operating faults

If the battery is too weak to ensure correct operation, you will still be able to start and lock/unlock the vehicle ➔ 39.

26913



 Do not throw away your used batteries as rubbish. Take them to an approved dealer or consult your local authority for information on appropriate recycling facilities.

CARD



Precautions relating to batteries:

- keep (new or used) batteries out of reach of children;

- do not swallow batteries;

Risk of chemical burns which may lead to death.

- if ingested or inserted into any part of the body, consult a doctor as soon as possible.

DOORS AND OPENING ELEMENTS

Opening and closing the doors

Opening the doors from the outside



Front doors

With the doors unlocked or the card on you, hold the **1** handle and pull towards you.

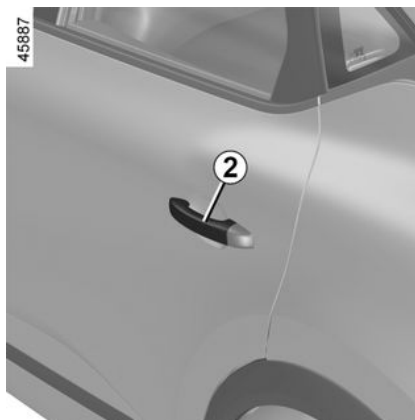

Rear doors

With the doors unlocked or the card on you, hold the **2** handle and pull towards you.

Opening from the inside

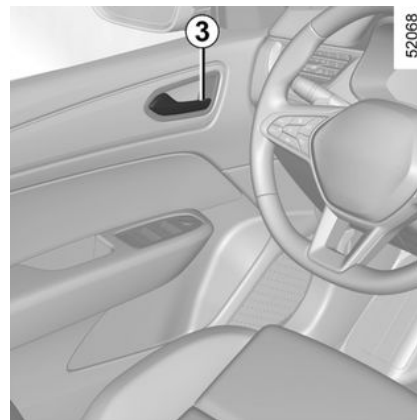

Pull handle **3** once.

Depending on the vehicle, it may be necessary to pull handle **3** twice: the first time to unlock the door, the second time to open it.



As a safety precaution, the doors should only be opened or closed when the vehicle is stationary.

DOORS AND OPENING ELEMENTS

Lights-on reminder buzzer

If you have switched off the ignition and left the lights switched on, a reminder buzzer will sound when a door is opened.

Door/tailgate open buzzer

When the vehicle is stationary, the

 warning light appears on the instrument panel accompanied by a warning light indicating which of the opening elements (door(s), luggage compartment) are open or incorrectly closed.

Once the vehicle reaches a speed of approximately 6 mph (10 km/h), a warning light indicates if the door(s) or luggage compartment are open or not properly closed, along with the message "Boot open" or "WARNING: Door Open" and a beep will sound for around 40 seconds or until the door/luggage compartment is closed.

Child safety

45661



Move lever **4** and check from the inside that the doors are securely locked, to prevent the rear doors being opened from the inside.



Driver's responsibility when parking or stopping the vehicle

Never leave an animal, child or adult who is not self-sufficient alone on your vehicle, even for a short time.

They may pose a risk to themselves or to others by starting the engine, activating equipment such as the electric windows or locking the doors. Also, in hot and/or sunny weather, please remember that the temperature inside the passenger compartment increases very quickly.

RISK OF DEATH OR SERIOUS INJURY.

Locking, unlocking the opening elements and doors

If the card does not work

In some cases, the card may not work:

- card battery worn or run flat, vehicle battery flat etc.

DOORS AND OPENING ELEMENTS

- use of appliances operating on the same frequency as the card (mobile phone, etc.);
- vehicle located in a high electro-magnetic radiation zone.

It is then possible :

- to use the emergency key integrated in the card to unlock the driver's door ;
- to use the interior door locking/unlocking control.

The card's built-in key



The **2** integrated key can be used to lock or unlock the driver's door when the card is not working.

Access with key **2**

Slide the rear casing **1** downwards while pressing on zone **A**.



Using the key integrated in the card

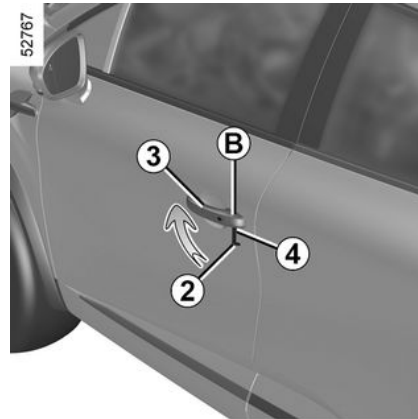

- Pull handle **3** ;
- press the cover **B** on the driver's door down ;
- insert the end of the key **2** in the notch **4** at the bottom of the cover **B** ;
- rotate it upwards to remove the cover **B** ;
- insert the key **2** into the lock of the driver's door, lock or unlock.

Once you are inside the vehicle, put the key back in its casing in the card.

DOORS AND OPENING ELEMENTS

Locking the doors manually

45718



Turn screw **5** with the door open (using the end of the key) and close the door.

This means that the doors are then locked from the outside.

The doors may then only be opened from the inside or by using the key in the driver's door.

Interior locking/unlocking door control

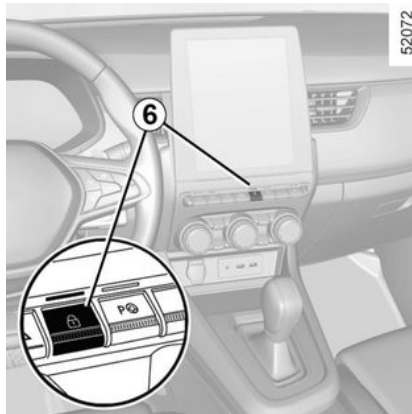

52072

Switch **6** controls the doors, the boot and the fuel filler flap simultaneously.

If a door or the tailgate is open or not closed properly, the doors and tailgate lock/unlock quickly.

If transporting an object with the tailgate open, you can still lock the doors : with the engine stopped, press and hold switch **6** to lock the other doors.

Door and tailgate status indicator

When the ignition is on, the **6** switch warning light indicates the locking status of the opening elements :

- indicator light on, the doors and tailgate are locked ;
- indicator light off, the doors and tailgate are unlocked.

When you lock the doors, the indicator light remains lit and then goes out.



Driver's responsibility

If you decide to keep the doors locked when you are driving, remember that it may be more difficult for those assisting you to gain access to the passenger compartment in the event of an emergency.

Locking the opening elements without the card

For example, in the event of a discharged battery or the card temporarily not working etc.

With the engine switched off and a door or tailgate open, press and

2

DOORS AND OPENING ELEMENTS

hold the **6** switch for more than five seconds.

When the door is closed, all the doors and the tailgate will be locked.

Note : unlocking the vehicle from the outside is only possible with the card in the vehicle's access zone.



Never leave your vehicle with the card inside.

Automatic locking when driving

Operating principle



After the vehicle is started, the system automatically locks the doors when you are driving at approximately 6 mph (10 km/h) and over.

The door can be unlocked :

- by pressing the central door unlocking switch **7** ;
- at a standstill, by opening a front door from inside the vehicle.

NB : if a door is opened or closed, it will automatically lock again when the vehicle reaches a speed of 6 mph (10 km/h).

Activating/deactivating the function

To activate : with the vehicle stationary and the engine running, press the **7** switch until a beep sounds.

To deactivate : with the vehicle stationary and the engine running, press the switch **7** until you hear two beeps.

The function can also be activated and deactivated via the multimedia screen (depending on the vehicle)

➔ 105.

Operating faults

If you experience an operating fault (no central locking, the indicator light **7** does not light up when trying

to lock the doors and luggage compartment etc.), make sure that central locking has not been deactivated by mistake and check that the doors and luggage compartment are properly closed. If they are properly closed, contact an approved dealer.



Driver's responsibility

If you decide to keep the doors locked when you are driving, remember that it may be more difficult for those assisting you to gain access to the passenger compartment in the event of an emergency.

DOORS AND OPENING ELEMENTS

Luggage compartment

To open

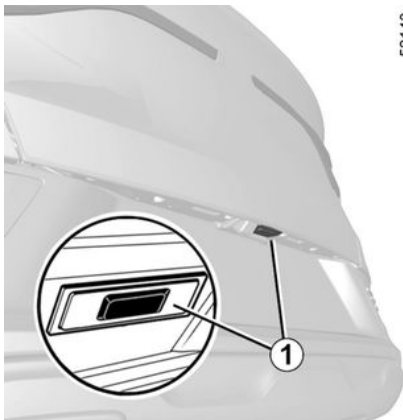

Press the **1** button to open the luggage compartment lid a few centimetres.

Lift the luggage compartment lid.

To close

Lower the tailgate using the handles **2** inside the tailgate to help you.



Never use the struts to close the luggage compartment door.

Opening the doors manually from the inside



If it is impossible to unlock the tailgate, it can be done manually from inside :

- access the luggage compartment by tilting the rear bench seatback(s),
- insert a pencil or similar object in recess **3** and slide the unit as shown in the illustration ;
- push the tailgate to open it.



The attaching of any carrying device (bike rack, luggage box etc.) resting on the luggage compartment lid is prohibited. To install a carrying device on your vehicle, contact an Approved Dealer.

FRONT SEATS

Front headrests

2 To raise the headrest

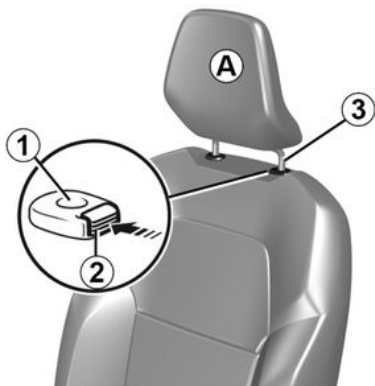

Pull the headrest upwards to the desired height. Check that it is correctly locked.

To lower the headrest

Press button **2** and guide the headrest down to the desired height. Check that the bonnet is correctly locked.

To raise the headrest

Raise it to its highest position (tilt the seatback backwards if necessary).

Press button **2** and lift the headrest to release it.

To refit the headrest

Check that the headrest rods are clean **3**.

Insert the headrest rods into the holes **1** (tilt the seatback backwards if necessary). Lower the headrest until it locks and press button **2** to adjust to the desired height. Check that each rod **3** on the seatback is securely locked.

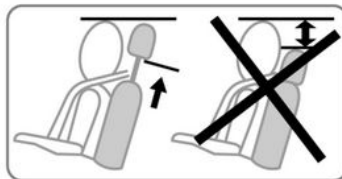

The headrest is important for safety. Ensure that it is in place and in the correct position: the top of the headrest should be as close as possible to the top of the head and there must be a minimal distance between the head and the headrest **A**.

Front seats

Adjusting the seat position

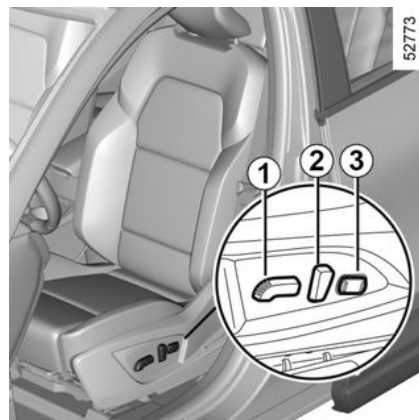

To move the seat forwards or back

FRONT SEATS

Move the **1** switch forwards or backwards or, depending on the vehicle, lift and hold the **4** handle to unlock the seat. Release the handle once the seat is in the correct position and ensure that the seat is locked.

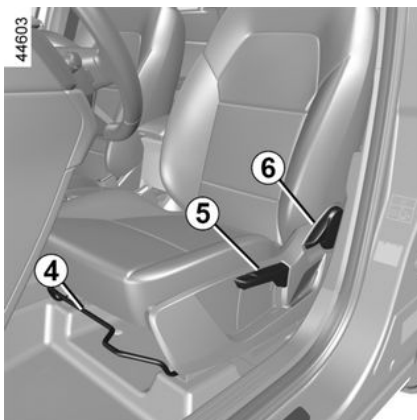

To raise or lower the seat base

Move the **1** switch up or down or, depending on the vehicle, move the **5** lever as many times as necessary upwards or downwards to the desired position.

Adjusting the seatback

To tilt the seatback

Activate the **2** switch forwards or backwards, or depending on the ve-

hicle, lift the **6** handle and tilt the seatback to the desired position. Release the handle at the desired position and make sure that it is locked.

To adjust the seat's lumbar position

Push left or right of the button **3** to increase or decrease the support.



For safety reasons, carry out any adjustments when the vehicle is not being driven.

We would advise you not to recline the seatbacks too far to ensure that the effectiveness of the seat belts is not reduced. Nothing should be placed on the floor (area in front of driver) as such objects may slide under the pedal during braking manoeuvres, thus obstructing its use.

Central armrest 7

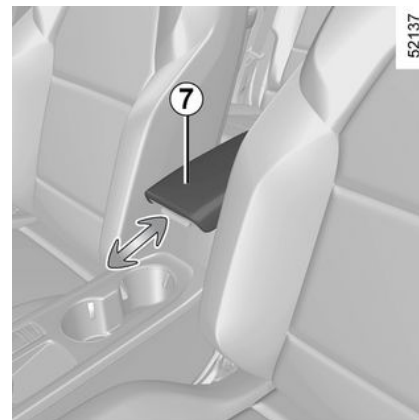

(depending on the vehicle)

To adjust the position of the central armrest **7**, slide it forwards or backwards.

Heated seats

(depending on the vehicle)

Vehicles fitted only with heated seats

With the ignition on:

- Pressing the switch **8** on the required seat for the first time activates the heating system on high. Both integrated switch warning lights come on;

FRONT SEATS

2



- pressing the switch for the second time changes the heating to low. One integrated warning light comes on;
- pressing for the third time turns the heating off.

Vehicles fitted with heated and ventilated seats

While the engine is running, pressing **8** displays setting on multimedia screen. Pressing **9** activates drivers or passengers heated seat.

Pressing **10** once or twice activates the heated seat at low or high level. Warning lights come on.



Pressing **8** again turns the heated seat off. Its warning lights go off.

Operating faults

When an operating fault is detected, the warning light of the **8** switch for the seat concerned switches-off after approximately five seconds. Consult an approved dealer.

Ventilated seats

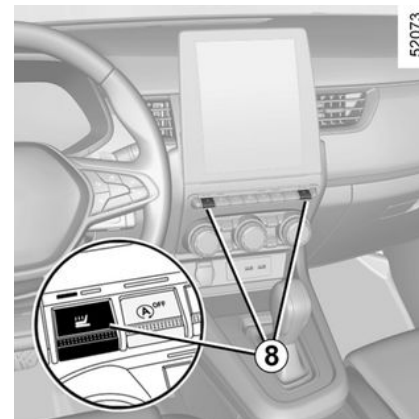

(depending on the vehicle)

Ventilation seats work on the principle of absorbing and exporting the air in the passenger compartment without using the vehicle's air conditioning and heating functions. For the best performance, you are advised to use this function with air conditioning switched on.

Note : this function is deactivated when the engine is off and on.

FRONT SEATS



While the engine is running :

- pressing **8** displays setting on multimedia screen. Pressing **9** activates drivers or passengers ventilated seat.
- pressing **11** once or twice activates the ventilated seat at low or high level. Warning lights come on.
- pressing **8** again turns the heated seat off. Its warning lights go off.

Operating faults

When an operating fault is detected, the warning light of the **8** switch for the seat concerned switches-off after approximately five seconds. Consult an approved dealer.

REAR SEATS

Rear headrests

2

Position for use

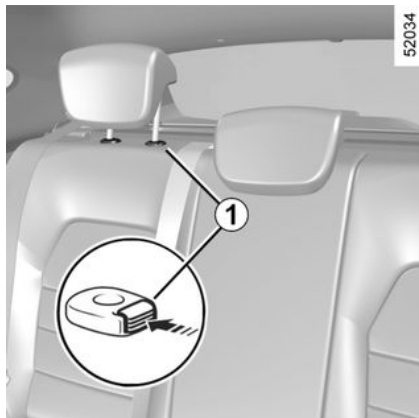

Raise the headrest as far as possible until it locks. Check that it is correctly locked.

To remove the headrest

Raise the headrest as far as it will go, then press button **1** and remove the headrest.

Note : The headrest **2** is fixed and can't be raised.

To refit the headrest

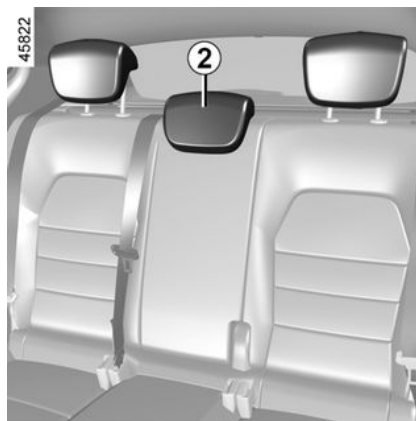

Fit the rods into their housing and push down the headrest until it locks to set it to raised position. Check that the bonnet is correctly locked.

Folding positions

Press the button **1** and lower the headrest completely.

Fixed headrest 2 for the rear center seat

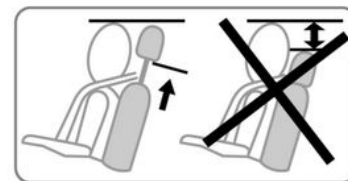

When the headrest is set at the lowest position, this is for storage only. It should not be in this position when a seat is occupied.



The headrest is a safety component; check that it is fitted and in the correct position.

REAR SEATS

Rear bench seat: functions

Functions

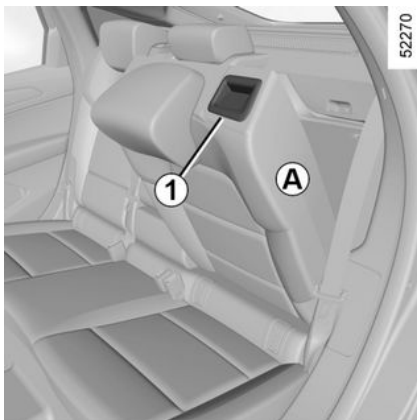

To fold down the seatback

Ensure that the front seats are far enough forward.

Lower the headrests fully.

Pull the vane **1** and lower the seatback **A**.

Before folding down any rear seat, fasten the seat belt of the seat concerned into the appropriate catch. This will prevent the seat belt becoming trapped when the seat is returned to its position to use.

In all cases, check that the seat belts are operating correctly.

To replace the seatback, proceed in the reverse order to removal.

Raise the seatback again until it reaches the locking joint of the seatback. Be careful not to jam the safety strap between the backrest and the parcel shelf.



When moving the rear seats, ensure that nothing obstructs the anchorage points (passenger's arm or leg, a pet, gravel, cloth, toys, etc.).



For safety reasons, carry out any adjustments when the vehicle is not being driven.



When refitting the seatback, make sure it is correctly locked in place.

If seat covers are fitted, make sure these do not prevent the seatback latch from locking in. Make sure that the seat belts are positioned correctly. Reposition the headrests.

SEAT BELTS

Seat belts

Always wear your seat belt when travelling in your vehicle. You must also comply with the legislation of the particular country you are in.

Before starting, first adjust your driving position, then ask all occupants to adjust their seat belts to ensure optimum protection.

Adjusting your driving position

- **Sit well back in your seat** (having first removed your coat or jacket). This is essential to ensure your back is positioned correctly ;
- **adjust the distance between the seat and the pedals.** Your seat should be as far back as possible while still allowing you to depress the pedals fully. The seatback should be adjusted so that your arms are slightly bent when you hold the steering wheel ;
- **adjust the position of your headrest.** For maximum safety, your head must be as close as possible to the headrest ;
- **adjust the height of the seat.** This adjustment allows you to select the seat position which offers you the best possible view ;
- **adjust the position of the steering wheel.**

 Make sure that the rear bench seat is locked in position correctly so that the rear seat belts will operate correctly. → 49



Incorrectly adjusted or twisted seat belts may cause injuries in the event of an accident.

Use one seat belt per person, whether child or adult. Even pregnant women should wear a seat belt. In this case, ensure that the lap belt is not exerting too much pressure on the abdomen, but do not allow any slack.

Adjusting the seat belts



For correct adjustment and positioning of the seat belts at all seats :

- adjust the seats (seat position and seatback angle, if available) ;
- sit with your back firmly against the seatback ;
- move the chest strap **1** as close as possible to the base of the neck without it actually resting against it (if necessary, adjust the height of the seat belt if available) and make sure that the chest strap **1** is in contact with the shoulder ;
- position the lap belt **2** so that it lies flat on the thighs and against the pelvis.

SEAT BELTS

The belt should be worn so that it is as close as possible to your body, i.e. : avoid wearing heavy clothing or keeping bulky objects under the belts, etc.

Locking

Unwind the belt **slowly and smoothly** and ensure that buckle **3** locks into catch **5** (check that it is locked by pulling on buckle **3**).

If the belt jams, allow it to return slightly before attempting to unwind it again.

If your seat belt is completely jammed, pull slowly, but firmly, so that just over 3 cm unwinds. Allow it to return slightly before attempting to unwind it again.

If there is still a problem, contact an approved dealer.

Unlocking

Press button **4** and the seat belt will be rewound by the inertia reel. Guide the belt.



Driver's seat belt reminder and, depending on the vehicle, front passenger seat belt reminder

This appears on the central display when the ignition is switched on and if the driver's or front passenger's

seat belt (as long as the passenger seat is occupied) is not fastened.

Depending on the vehicle, if the seat is occupied and one of these seat belts is not fastened or becomes unfastened while the vehicle is moving at a speed over approximately 12

mph (20 km/h), the  warning light flashes and a beep sounds for approximately 120 seconds.

Note : an object placed on the passenger seat may activate the warning light in some cases, depending on the vehicle.

Rear seat belt reminder (depending on vehicle)

The **6** graphic is displayed on the instrument panel when the ignition is switched on. This informs the driver of the fastening status of each of the rear seat belts every time :

- the ignition is switched on ;
- a door is opened ;
- fastening or unfastening of a rear seat belt.

Understanding the graphic **6** :

- indicator green : seatbelt fastened ;
- indicator red : the seat is occupied and the seat belt is not fastened ;
- indicator grey : seat not occupied.



The  warning light on the central display also appears when the ignition is switched on, if a rear seat is occupied and the seat belt is not fastened.

When the vehicle speed is less than approximately 12 mph (20 km/h), the

 warning light on the central display appears if a rear seat is occupied and the seat belt is not fastened.

It is accompanied by the **6** symbol which appears for approximately 60 seconds each time one of the rear seat belts is fastened or unfastened.

SEAT BELTS

When the vehicle speed exceeds approximately 12 mph (20 km/h), if one of the rear seat belts is or becomes unfastened during the journey :

2

- the  warning light flashes on the central display ;
- and
- a beep sounds for around 120 seconds ;
- and
- the **6** symbol is displayed for approximately 180 seconds and the symbol for the seat concerned changes to red.

Always make sure that the rear passengers are properly fastened and that the number of fastened seat belts indicated corresponds to the number of rear seat occupied.

Note : in some cases that alerts may be activated if an object is placed on one of the rear seats, depending on the vehicle.

Adjusting the height of the front seat belts



Use button **7** to adjust the seat belt height so that the shoulder strap is worn as shown previously. Press the button **7** and raise or lower the seat belt. Make sure that the seat belt is locked in position correctly after you have adjusted it.

Rear seat belts

Rear side seat belts 8

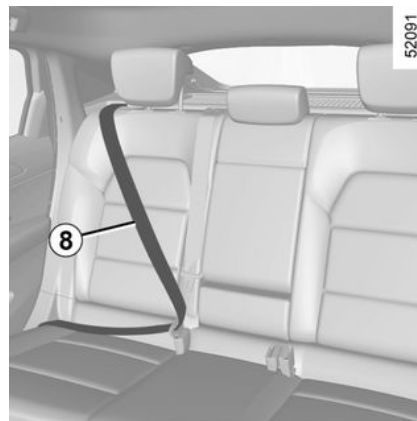

The belts are locked, unlocked and adjusted in the same way as the front belts.



Check that the rear seat belts are positioned and operating correctly each time the rear bench seat is moved.

SEAT BELTS

Rear centre seat belt

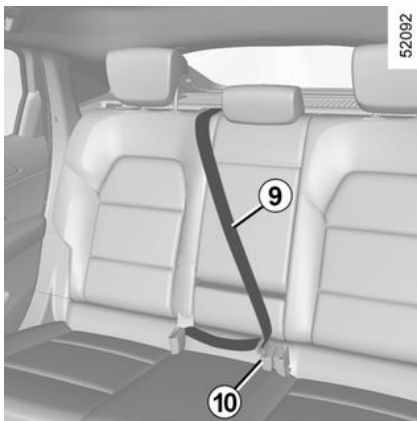

Slowly unwind belt **9**.

Click buckle into black catch **10**.

The following information applies to the vehicle's front and rear seat belts.



- No modification may be made to the component parts of the originally fitted restraint system : seat belts, seats and their mountings. For special operations (e.g. fitting child seats), contact an authorised dealer.
- Do not use devices which allow any slack in the belts (e.g. clothes pegs, clips, etc.) : a seat belt which is worn too loosely may cause injury in the event of an accident.
- Never wear the shoulder strap under your arm or behind your back.
- Never use the same belt for more than one person and never hold a baby or child on your lap with your seat belt around them.
- The belt should never be twisted.
- Following an accident, have the seat belts checked and replaced if necessary. Always replace your seat belts as soon as they show any signs of wear.

- When the rear bench seat is being put back, make sure that the seat belts and buckles are correctly positioned so that they can be used properly.
- Make sure that the buckle is inserted into the appropriate catch.
- Ensure that no objects are placed in the area around the seat belt catch as they could prevent it from being properly secured.
- Make sure the seat belt catch is properly positioned (it should not be hidden away, crushed or flattened by people or objects).

ADDITIONAL SAFETY DEVICES

Methods of restraint in addition to the front seat belts

Depending on the vehicle, they will consist of :

- **seat belt inertia reel pretensioners ;**
- **central seat belt pretensioners ;**
- **chest-level load limiters ;**
- airbags **driver and passenger front.**

These systems are designed to act independently or together when the vehicle is subjected to a frontal impact.

Depending on the severity of the impact, the system can trigger :

- seat belt locking ;
- the seat belt inertia reel pretensioner (which engages to correct seat belt slack) ;
- lap seat belt pretensioners to hold the occupant in their seat ;
- the front airbag.

Pretensioners

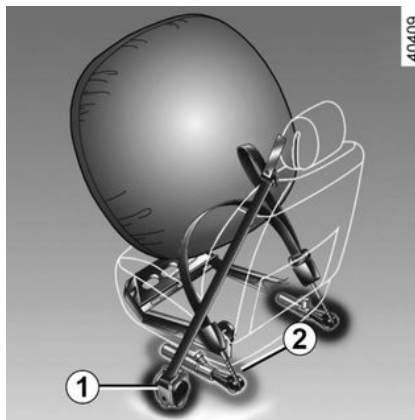

The pretensioners hold the seat belt against the body, holding the occupant more securely against the seat, thus increasing the seat belt's efficiency.

In the event of a severe frontal impact and if the ignition is switched on, the system may engage the following depending on the force of the impact :

- the seat belt inertia reel pretensioner **1** which instantly retracts the seat belt ;
- the lap seat belt inertia reel pretensioner **2** on the front seats.



- Have the entire restraint system checked following an accident.
- No operation whatsoever is permitted on any part of the system (pretensioners, airbags, computers, wiring) and the system components must not be reused on any other vehicle, even if identical.
- Only qualified personnel from our Network may work on the airbags ; otherwise the system may trigger accidentally and cause injury.
- The electric trigger system may only be tested by a specially trained technician using special equipment.
- When the vehicle is scrapped, contact an approved dealer for disposal of the pretensioner and airbags gas generators.

Load limiter

Above a certain severity of impact, this mechanism is used to limit the force of the belt against the body so that it is at an acceptable level.

ADDITIONAL SAFETY DEVICES

Driver and passenger front Airbags

Fitted to the driver and passenger sides.

A symbol on the lower section of the windscreen indicates if this equipment is present (depending on the vehicle).

Each airbag system consists of :

- an airbag and gas generator fitted on the steering wheel for the driver and in the dashboard for the passenger ;
- an electronic unit for system monitoring which controls the gas generator electrical trigger system ;
- remote sensors ;
- a single warning light  on the instrument panel.

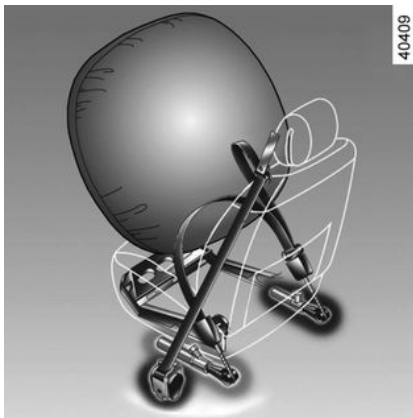

Operation

This system is only operational when the ignition is switched on.

In a severe frontal impact, the airbags inflate rapidly, cushioning the impact of the driver's head and chest against the steering wheel and of the front passenger against the dashboard. The air bags then deflate immediately so that the passengers are not in any way hindered from leaving the vehicle.

Operating faults



This warning light comes on when the engine is started and then

goes out after approximately three seconds.

If it does not come on when the ignition is switched on or if it stays on, there is a fault in the system.

Contact your approved Dealer as soon as possible.

Your protection will be reduced until this fault is rectified.



The airbag system uses pyrotechnic principles. This explains why, when the airbag inflates, it will generate heat, produce smoke (this does not mean that a fire is about to start) and make a banging noise. In a situation where an airbag is required, it will inflate immediately and this may cause some minor, superficial grazing to the skin or other problems.

ADDITIONAL SAFETY DEVICES

2

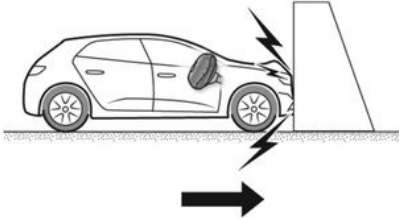

The following conditions will trigger the pretensioners or airbags.
In a frontal impact against a rigid (non-deformable) surface at an impact speed equal to or greater than 16 mph (25 km/h).

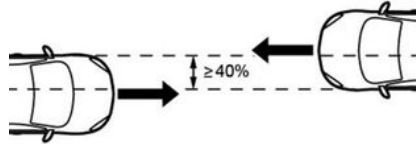

In a frontal impact with another vehicle of an equivalent or higher category, with an impact area equal to or greater than 40 %, where the speed of both vehicles is equal to or greater than 25 mph (40 km/h).

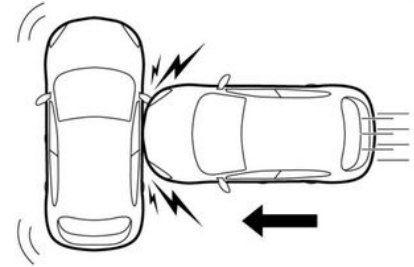

In a side impact with another vehicle of an equivalent or higher category, at an impact speed equal to or greater than 31 mph (50 km/h).

ADDITIONAL SAFETY DEVICES



In the following examples, the pretensioners or the airbags could operate :

- impact under vehicle such as pavement ;
- potholes ;
- drop or hard landing ;
- stones ;
- ...

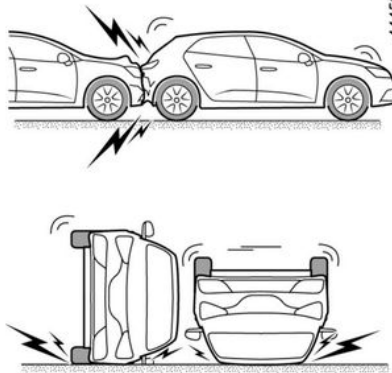

In the following examples, there is a risk that pretensioners or airbags may not be triggered :

- rear impact, however severe ;
- the vehicle overturning ;

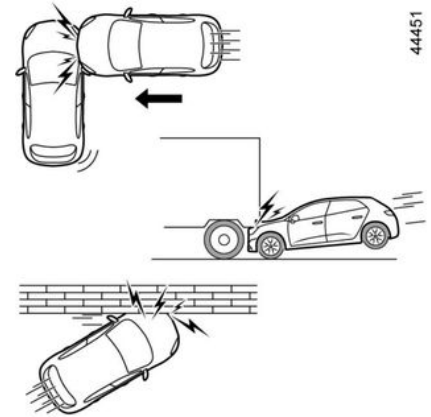

- side impact, affecting the front of the vehicle ;
- frontal impact, under the tail of a lorry ;
- frontal impact against an obstacle with a sharp angle ;
- ...

All of the warnings below are given so that the airbag is not obstructed in any way when it is inflated and also to prevent the risk of serious injuries caused by items which may be dislodged when it inflates.

ADDITIONAL SAFETY DEVICES

2



Warnings concerning the driver's airbag

- Do not modify the steering wheel or the steering wheel boss.
- Do not cover the steering wheel boss under any circumstances.
- Do not attach any objects (badge, logo, clock, telephone holder, etc.) to the steering wheel boss.
- The steering wheel must not be removed (except by qualified personnel from our Network).
- Do not sit too close to the steering wheel when driving : sit with your arms slightly bent (see "Adjusting your driving position" → 50). This will allow sufficient space for the airbag to deploy correctly and be fully effective.

Warnings concerning the passenger airbag

- Do not attach or glue any objects (badge, logo, clock, telephone holder, etc.) to the dashboard on or near the airbag.
- Do not place anything between the dashboard and the passenger (pet, umbrella, walking stick, parcels, etc.).
- The passenger must not put his or her feet on the dashboard or seat as there is a risk that serious injuries may occur. In general, parts of the body should be kept away from the dashboard (knees, hands, head, etc.).
- The devices in addition to the front passenger seat belt should be reactivated as soon as a child seat is removed, to ensure the protection of the passenger in the event of an impact.

A REAR-FACING CHILD SEAT MUST NOT BE FITTED TO THE FRONT PASSENGER SEAT UNLESS THE RESTRAINT SYSTEMS IN ADDITION TO THE FRONT PASSENGER SEATBELT ARE DEACTIVATED. → 78

Methods of restraint in addition to the rear seat belts

Depending on the vehicle, they will consist of :

- **side seat belt inertia reel pretensioners ;**
- **chest force limiters.**

These systems are designed to act independently or together when the vehicle is subjected to a frontal impact.

Depending on the severity of the impact, the system can trigger :

- seat belt locking ;
- the seat belt inertia reel pretensioner (which engages to correct seat belt slack).

Force limiter

Above a certain severity of impact, this mechanism is used to limit the force of the belt against the body so that it is at an acceptable level.

ADDITIONAL SAFETY DEVICES

Side seat belt pretensioners

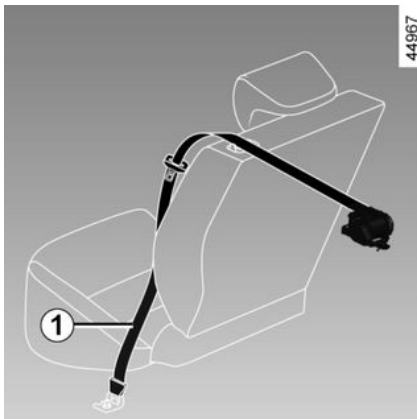

The pretensioners hold the seat belt against the body, holding the occupant more securely against the seat, thus increasing the seat belt's efficiency.

With the ignition on, following a significant frontal impact and depending on the severity of the impact, the system may trigger the seat belt inertia reel pretensioner **1**, which instantly retracts the seat belt.



- Have the entire restraint system checked following an accident.
- No operation whatsoever is permitted on any part of the system (pretensioners, airbags, computers, wiring) and the system components must not be reused on any other vehicle, even if identical.
- Only qualified personnel from our Network may work on the airbags; otherwise the system may trigger accidentally and cause injury.
- The electric trigger system may only be tested by a specially trained technician using special equipment.
- When the vehicle is scrapped, contact an approved dealer for disposal of the pretensioner and airbags gas generators.

Side protection devices

Side Airbag

This airbag may be fitted to each of the front seats and is activated at

the sides of the seats (door side) to protect the occupants in the event of a severe side impact.

Curtain Airbag

This is an airbag fitted along the upper sides of the vehicle – they inflate along the front and rear door side windows to protect the passengers in the event of a severe side impact.

ADDITIONAL SAFETY DEVICES

2



Warning relating to the side airbag

– Fitting seat covers :

seats equipped with an airbag require covers specifically designed for your vehicle. Contact an approved dealer to find out if these covers are available. The use of any covers other than those designed for your vehicle (including those designed for another vehicle) may affect the operation of the airbag and reduce your protection.

– Do not place any accessories, objects or even pets between the seatback, the door and the internal fittings. Do not cover the seatback with any items such as clothes or accessories. This may prevent the air bag from operating correctly or cause injury when the airbag is deployed.

– No work or modification whatsoever may be carried out on the seat or internal fittings, except by qualified personnel from an approved Dealer.

– This airbag operates through slits in the front seatbacks (door side) : never insert any objects in these slits.

Additional methods of restraint

All of the warnings below are given so that the airbag is not obstructed in any way when it is inflated and also to prevent the risk of serious injuries caused by items which may be dislodged when it inflates.



The airbag is designed to complement the action of the seat belt.

Both the airbag and the seat belt are integral parts of the same protection system. It is therefore essential to wear seat belts at all times. If seat belts are not worn, the occupants are exposed to the risk of serious injury in the event of an accident. It may also increase the risk of minor superficial injuries occurring when the airbag is deployed, although such minor injuries are always possible with airbags. If the vehicle should overturn or in the event of a rear impact, however severe, the pretensioners and airbags are not always triggered. Impacts to the underside of the vehicle, e.g. from pavements, potholes or stones, can all trigger these systems.

ADDITIONAL SAFETY DEVICES

- No work or modification **whatsoever** may be carried out on any part of the airbag system (airbags, pretensioners, computer, wiring harness, etc.), except by qualified Network personnel.
- To ensure that the system is in good working order and to avoid accidental triggering of the system which may cause injury, only qualified Network personnel may work on the airbag system.
- As a safety precaution, have the airbag system checked if your vehicle has been involved in an accident, or is stolen or broken into.
- When selling or lending the vehicle, inform the user of these points and hand over this manual with the vehicle.
- When scrapping your vehicle, contact your approved Dealer for disposal of the gas generator(s).

CHILD SAFETY

General information

2

Carrying children

Please ensure that you comply with the legislation of your country.

Children, and adults, must be correctly seated and strapped in for all journeys. The children being carried in your vehicle are your responsibility.

A child is not a miniature adult. Children are at risk of specific injuries as their muscles and bones have not yet finished growing. The seat belt alone would not provide suitable protection. Use an approved child seat and ensure you use it correctly.



To prevent the doors being opened, use the "Child lock" feature.

→ 38



A collision at 30 mph (50 km/h) is the same as falling a distance of 10 metres. Transporting a child without a restraint is the equivalent of allowing him or her to play on a fourth-floor balcony without railings. Never travel with a child held in your arms. In the event of an accident, you will not be able to keep hold of the child, even if you yourself are wearing a seat belt. If your vehicle has been involved in a road accident, replace the child seat and have the seat belts and ISOFIX anchorage points checked.



Driver's responsibility when parking or stopping the vehicle

Never leave an animal, child or adult who is not self-sufficient alone on your vehicle, even for a short time. They may pose a risk to themselves or to others by starting the engine, activating equipment such as the electric windows or by locking the doors. Also, in hot and/or sunny weather, please remember that the temperature inside the passenger compartment increases very quickly.

RISK OF DEATH OR SERIOUS INJURY.

Using a child seat

The level of protection offered by the child seat depends on its ability to restrain your child and on its installation. Incorrect installation compromises the protection it offers the child in the event of harsh braking or an impact.

Before purchasing a child seat, check that it complies with the regu-

CHILD SAFETY

lations for the country you are in and that it can be fitted in your vehicle. Consult an approved dealer to find out which seats are recommended for your vehicle.

The regulations on transporting children are specific to each country. The use of a child seat depends on the age and/or the size and/or weight of the child.

For children who do not need to be transported in a child seat, make sure that the seat belt is correctly adjusted and fastened.

In all cases, you must comply with the regulations of the particular country you are in.

Before fitting a child seat, read the manual and respect its instructions. If you experience any difficulties during installation, contact the manufacturer of the equipment. Keep the instructions with the seat.



Set a good example by always fastening your seat belt and teaching your child :

- to strap themselves in correctly ;
- to always get in and out of the car at the kerb, away from busy traffic.

Do not use a second-hand child seat or one without an instruction manual.

Check that there are no objects in the vicinity of the child seat which could impede its operation.



Never leave a child unattended in the vehicle. Check that your child is always strapped in and

that the belt or safety harness used is correctly set and adjusted. Avoid wearing bulky clothing which could cause the belts to slacken. → 50

Never let your child put their head or arms out of the window. Check that the child is in the correct position for the entire journey, especially if asleep.

CHILD SAFETY

Choosing a child seat

2



31235

Rear-facing child seats

A baby's head is, proportionally, heavier than that of an adult and its neck is very fragile. Transport the child in this position for as long as possible (until the age of 2 at the very least). It supports both the head and the neck.

Choose a bucket type seat for best side protection and change it as soon as the child's head is higher than the shell.



38824

Forward-facing child seats

The child's head and abdomen need to be protected as a priority. A forward-facing child seat which is firmly attached to the vehicle will reduce the risk of impact to the head. Ensure your child travels in a forward-facing seat with a harness for as long as their size permits.

Choose a bucket type seat for optimum side protection.



31234

Booster cushions

From 15 kg or 4 years, the child can travel using a booster seat, which will enable the seat belt to be adapted to suit his/her size and shape. The booster seat cushion must be fitted with guides to position the seat belt on the child's thighs rather than the stomach. It is recommended that you use a seatback fitted with a belt strap guide which can be adjusted in terms of height to position the seat belt in the centre of the shoulder. It must never rest on the neck or on the arm.

Choose a bucket type seat for optimum side protection.

CHILD SAFETY

Choosing a child seat mounting

There are two ways of attaching child seats : via the seat belt or using the ISOFIX system.

Attachment via the seat belt

The seat belt must be adjusted to ensure that it is effective in the event of harsh braking or an impact.

Ensure that the strap paths indicated by the child seat manufacturer are respected.

Always check that the seat belt is correctly fastened by pulling it up, then pulling it out fully whilst pressing on the child seat.

Check that the seat is correctly held by moving it from side to side and back to front : the seat should remain firmly fixed.

Check that the child seat has not been installed at an angle and that it is not resting against a window.

Attachment using the ISOFIX system

Approved child seats ISOFIX are standardised in accordance with current regulations if any of the four cases below applies :

- ISOFIX universal 3-point forward-facing seat ;

- ISOFIX semi-universal 2-point seat ;
- specific ;
- i-Size which has either :
 - a strap which attaches to the third ring of the seat concerned ;
 - or a strut that rests on the vehicle floor, compatible with the approved seat i-Size, the role of which is to prevent the child seat from moving in the event of a collision.

In the latter three cases check that your child seat can be installed by consulting the list of compatible vehicles.



Do not use the child seat if it may unfasten the seat belt restraining it : the base of the seat must not rest on the buckle and/or catch of the seat belt.



The seat belt must never be twisted or the tension relieved. Never pass the shoulder strap under the arm or behind the back.

Check that the seat belt has not been damaged by sharp edges. If the seat belt does not operate normally, it will not protect the child. Consult an approved dealer. Do not use this seat until the seat belt has been repaired.



No modifications may be made to the component parts of the restraint system (seat belts, ISOFIX and seats and their mountings) originally fitted.

CHILD SAFETY

2



The ISOFIX anchorage points have been exclusively designed for child seats with the

ISOFIX system. Never fit a different type of child seat, seat belt or other objects to these anchorage points.

Check that nothing is obstructing the anchorage points.

If your vehicle has been involved in a road accident, have the ISOFIX anchorage points checked and replace your child seat.

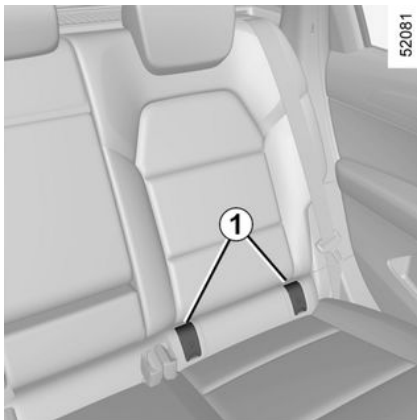

Attach the child seat with the ISOFIX locks, if these are provided. The ISOFIX system allows quick, easy, safe fitting.

The ISOFIX system consists of 2 rings and, in some cases, a third ring.

The two rings are located behind the zip fasteners **1** between the seat back and seat base and are identified by a  marking.



Before using an ISOFIX child seat that you purchased for another vehicle, check that its installation is authorised. Consult the list of vehicles which can be fitted with the seat from the equipment manufacturer.

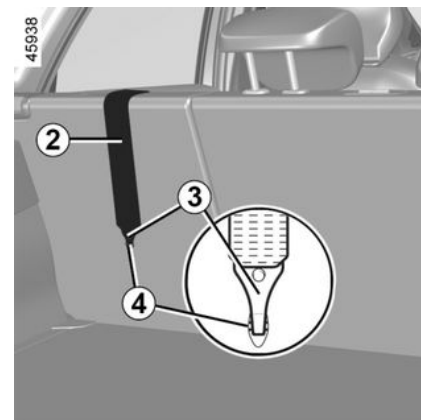

Attachment using the ISOFIX system (continued)

The third ring **4** is used to attach the upper strap **2** on some child seats.

Rear side seats

The upper strap **2** should be positioned between the seatback and the rear parcel shelf. To do so, remove the rear parcel shelf. → **277**

Attach the **3** hook on one of the **4**

rings marked with the  symbol.

CHILD SAFETY



The ISOFIX anchorage points have been exclusively designed for child seats with the ISOFIX system. Never fit a different type of child seat, seat belt or other objects to these anchorage points. Check that nothing is obstructing the anchorage points. If your vehicle has been involved in a road accident, have the ISOFIX anchorage points checked and replace your child seat.



Check that the seat-back of the forward-facing child seat is in contact with the back of the vehicle seat. In this case, the child seat may not always rest on the base of the vehicle seat.

CHILD SEATS

2

Fitting a child seat, general information

Some seats are not suitable for fitting child seats. The diagram shows you how to attach a child seat.



Fit the child seat in a rear seat wherever possible.

Make sure the child seat or the child's feet do not prevent the front seat from locking correctly. → 44

Check that when installing the child seat in the vehicle it is not at risk of coming loose from its base.

If you have to remove the headrest, check that it is correctly stored so that it does not come loose under harsh braking or impact.

Always attach the child seat to the vehicle even if it is not in use so that it does not come loose under harsh braking or impact.

The types of child seat indicated may not be available. Before using a

different child seat, check with the manufacturer that it can be fitted.

In the front seat

The laws concerning children travelling in the front passenger seat differ in every country. Consult the legislation in force and follow the indications on the diagram.

Before fitting a child seat in this seat (if authorised):

- lower the seat belt as far as possible;
- move the seat as far back as possible;
- gently tilt the seatback away from vertical (approximately 25°);
- on equipped vehicles, raise the seat base as far as possible.

Always fully raise the seat headrest so that it does not interfere with the child seat. → 44

After installing the child seat, when this is possible, you can move the vehicle seat forward if necessary (so as to leave enough space in the rear seats for passengers or other child seats). For a rear-facing child seat, do not let it touch the dashboard or move it to the furthest forward position.

Do not change other settings after installing the child seat.



RISK OF DEATH OR SERIOUS INJURY : before

fitting a rear-facing child seat in this seat, make sure that the front passenger airbag has been deactivated. → 78

In the rear side seat

A carrycot can be installed across the vehicle and will take up at least two seats. Position the child with his or her feet nearest the door.

Move the front seat as far forward as possible to install a rear-facing child seat, then move back the seat in front as far as it will go, although without allowing it to come into contact with the child seat.

For the safety of the child in the forward-facing position :

- move the relevant seat backwards as far as possible;
- move the seat in front of the child forwards, and set the position of the seatback to avoid contact between the seat and the child's legs.

CHILD SEATS



Ensure that the child seat or the child's feet do not prevent the front seat from locking correctly. → 49

Always remove the headrest from the rear seat on which the child seat is positioned. → 48 If necessary, position the rear seat as far back as possible. This must be done before fitting the child seat. Check that the child seat is resting against the back of the rear seat.



Installing a booster seat (group 2 or 3)
Check the operation (rolling up) of the seat

belt. → 50

Adjust the seat belt by positioning:

- the shoulder strap on the child's shoulder without touching the neck;
- the lap belt so that it lies flat on the thighs and against the pelvis.

If necessary, adjust the position of the vehicle seat.



A child seat with floor supports must never be installed on the rear centre seat.

RISK OF DEATH OR SERIOUS INJURY.



Fit the child seat in a rear seat wherever possible.

To install an ISOFIX seat in this seat, unbuckle the seat belt by hand before engaging the bolts.



Fitting a seat ISOFIX in the rear-left seat means the middle seat cannot be used. The central seat belt will no longer be either accessible or useable.

CHILD SEATS

Fitting diagram

2



54217

CHILD SEATS



RISK OF DEATH OR SERIOUS INJURY : before fitting a rear-facing child seat in this seat, make sure that the front passenger airbag has been deactivated. → 78

2



For the rear central seat, the use of a child seat without a floor support leg is recommended.



Using a child safety system which is not approved for this vehicle will not correctly protect the baby or child.
Risk of injury.



Check the status of the airbag before fitting a child seat or allowing a passenger to use the seat.



Seat not suitable for fitting child seats.

Child seat attached using the belt



Seat which allows a child seat with "Universal" approval to be attached by a seat belt.

B2 : Seat allowing a "B2" approved child seat to be installed.

B3 : Seat allowing a "B3" approved child seat to be installed.



Check that your child is always strapped in and that the belt or safety harness used is correctly set and adjusted. → 50
If necessary, adjust the seat position accordingly.

CHILD SEATS

Installation table

The table below summarises the information already shown on the diagram, to ensure the regulations in force are respected.

Five-seater version					
Type of child seat	Weight of the child	Front passenger seat		Rear side seats	Rear centre seat
		With airbag disabled	With airbag activated		
Carrycot fitted across the vehicle Group 0	< 10 kg	X	X	U (2)	X
Rear-facing shell seat Groups 0 or 0 +	< 10 kg and < 13 kg	X	X	U (3)	U (3) (6)
Shell seat/rear-facing seat Groups 0+ and 1	< 13 kg and 9 to 18 kg	X	X	U (3)	U (3) (6)
Forward-facing seat Group 1	9 to 18 kg	U (5)	U (5)	U (3) (4)	U (4) (6)
Booster seat Groups 2 and 3	15 to 25 kg and 22 to 36 kg	U (5)	U (5)	U (3) (4)	U (4)



(1) RISK OF DEATH OR SERIOUS INJURY : before fitting a rear-facing child seat in this seat, make sure that the front passenger airbag has been deactivated. → 78

X= Seat not suitable for fitting child seats of this type.

CHILD SEATS

U= Seat allowing a child seat with "Universal" approval to be attached using the seat belt; check that it can be fitted.

B2= Seat allowing a child seat with "B2" approval to be attached by the seat belt; check that it can be fitted.

B3= Seat allowing a child seat with "B3" approval to be attached by the seat belt; check that it can be fitted.

(2) A carrycot can be installed across the vehicle and will take up at least two seats. Position the child with his or her feet nearest the door.

(3) If necessary, position the vehicle seat as far back as possible. In order to install a rear-facing child seat, move the front seat as far forward as possible, then move the front seat back as far as it will go, without allowing it to come into contact with the child seat.

(4) In all situations, remove the rear headrest of the seat on which the child seat is positioned. This must be done before fitting the child seat. → **48** Move the seat in front of the child forwards, move the seatback forward to avoid contact between the seat and the child's legs.

(5) Raise the seat to the maximum and position it as far back as possible, tilting the seatback slightly (approximately 25°).



(6) RISK OF DEATH OR SERIOUS INJURY : a child seat with a support leg must never be fitted.

CHILD SEATS

Fitted using the ISOFIX

The table below summarises the information already shown in the diagram, to ensure the applicable regulations are respected.

Type of child seat	Weight of the child	Seat size ISOFIX	Front passenger seat		Rear side seats	Rear centre seat
			With airbag disabled	With airbag activated		
Carrycot fitted across the vehicle Group 0	< 10 kg	L1 [F], L2 [G]	X	X	X	X
Rear-facing shell seat Groups 0 or 0 +	< 10 kg and < 13 kg	R1 [E]	X	X	IL (3)	X
Shell seat/rear-facing seat Groups 0+ and 1	< 13 kg and 9 to 18 kg	R3 [C], R2 [D]	X	X	IL (3)	X
Forward-facing seat Group 1	9 to 18 kg	F3 [A], F2 [B], F2X [B1]	X	X	IUF - IL (3) (4)	X
Booster seat Groups 2 and 3	15 to 25 kg and 22 to 36 kg	B2, B3	X	X	IUF - IL (3) (4)	X
Seat i-Size			X	X	i-U (3) (4)	X

X= Seat not suitable for fitting child seats of this type.

IUF/IL = On equipped vehicles, seat which allows an approved "Universal/semi-universal" or "vehicle specific" child seat to be attached using the ISOFIX system ; check that it can be fitted.

i-U = Suitable for "universal" front-facing and rear-facing i-Size restraint devices.

CHILD SEATS

i-UF = Suitable only for “universal” front-facing and rear-facing i-Size restraint devices.

- (1)** A carrycot can be installed across the vehicle and will take up at least two seats. Position the child with his or her feet nearest the door.
- (2)** Raise the seat to the maximum and position it as far back as possible, tilting the seatback slightly (approximately 25°).
- (3)** If necessary, position the vehicle seat as far back as possible and raise the seatback (approximately 25°). In order to install a rear-facing child seat, move the front seat as far forward as possible, then move the front seat back as far as it will go, without allowing it to come into contact with the child seat.
- (4)** In all situations, remove the rear headrest of the seat on which the child seat is positioned. This must be done before fitting the child seat. → **48** Move the seat in front of the child forwards, move the seatback forward to avoid contact between the seat and the child’s legs.

The size of the ISOFIX child seat is indicated by a letter :

- A, B, B1 [F3, F2, F2X] : for forward-facing seats in group 1 (9 to 18 kg) ;
- C and D [R3, R2] : shell seat or rear-facing seats in group 0+ (less than 13 kg) or group 1 (9 to 18 kg) ;
- E [R1] : rear-facing shell seats in group 0 (less than 10 kg) or 0+ (less than 13 kg) ;
- F and G [L1, L2] : cots in group 0 (less than 10 kg) ;
- [B2, B3] : boosters in group 2 and 3 (15 to 25 kg and 22 to 36 kg).



(5) RISK OF DEATH OR SERIOUS INJURY : before fitting a rear-facing child seat in this seat, make sure that the front passenger airbag has been deactivated. → **78**



Check that your child is always strapped in and that the belt or safety harness used is correctly set and adjusted. → **50**
If necessary, adjust the seat position accordingly.

CHILD SEATS

Fitting diagram

2



52669

CHILD SEATS



For the front passenger seat, the use of a child seat with a floor support is recommended to avoid triggering the seat belt warning signal.



Using a child safety system which is not approved for this vehicle will not correctly protect the baby or child. Risk of injury.



Seat which does not allow a child seat to be fitted.



RISK OF DEATH OR SERIOUS INJURY :

before fitting a rear facing child seat on the front passenger seat, check that the airbag has been deactivated. → 78

Child seat fitted using the ISOFIX mounting



Seat which allows an ISOFIX child seat to be fitted.



The rear seats are fitted with an anchorage point which allows a forward-facing ISOFIX child seat with universal approval to be attached. The anchoring points are located on the passenger seatback for the front seat and on the bench seatback for the rear seats.



Fit the child seat in a rear seat wherever possible.
To install an ISOFIX seat in this seat, unbuckle the seat belt by hand before engaging the bolts.



Fitting a seat ISOFIX in the rear-left seat means the middle seat cannot be used. The central seat belt will no longer be either accessible or useable.

CHILD SAFETY: DEACTIVATING, ACTIVATING THE FRONT PASSENGER AIRBAG

Deactivating the front passenger airbag

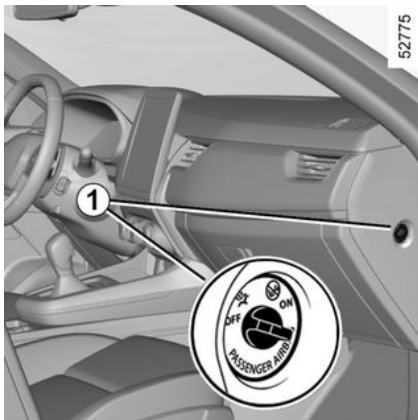

(depending on the vehicle)

Before installing a child seat on the front passenger seat:

- check that the child seat can be installed on this seat;
- it is essential **to deactivate** the airbag for a rear-facing child seat.

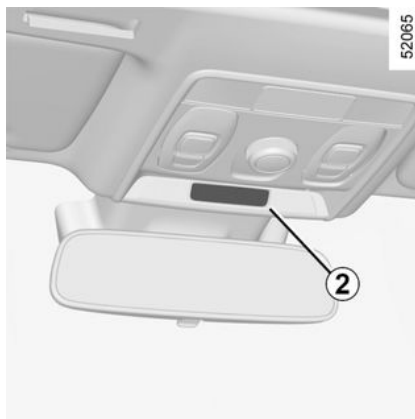

To deactivate the airbag: with the vehicle stationary and the ignition switched off, push and turn lock 1 to the OFF position.

When the ignition is switched on, it is **essential** to check that the warning

light  is illuminated on the display 2.

This light remains permanently lit to let you know that you can fit a child seat.



The passenger airbag may only be activated or deactivated when the **vehicle is stationary with the ignition off.**

If it is interfered with when the vehicle is being driven, indicator

lights  and  will come on.

Switch the ignition off then on again to reset the airbag in accordance with the lock position.



DANGER

Since operation of the front passenger airbag is not compatible with the position of a rear-facing child seat, **NEVER fit a rear-facing child restraint system in a seat protected by an ACTIVATED front AIRBAG. This can lead to the DEATH of the CHILD or SERIOUS INJURY.**

CHILD SAFETY: DEACTIVATING, ACTIVATING THE FRONT PASSENGER AIRBAG

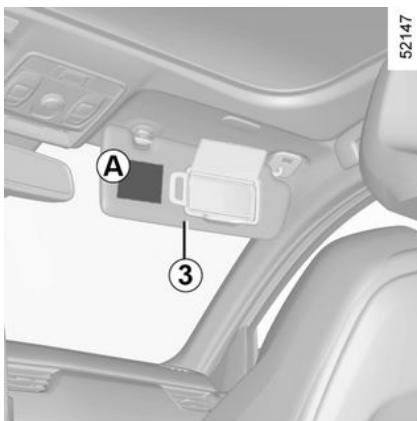

58034



The markings on the dashboard and labels **A** on each side of the passenger sun visor **3** (example : label shown above) remind you of these instructions.

Activating the front passenger airbag

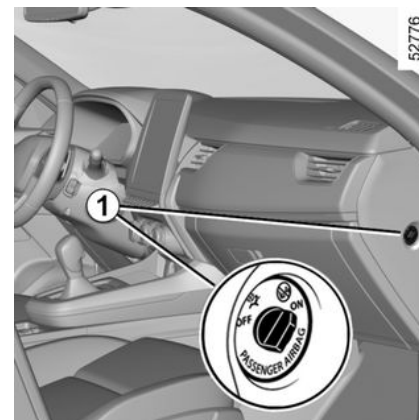

(depending on the vehicle)

You should reactivate the airbag as soon as you remove the child seat from the front passenger seat to ensure the protection of the front passenger in the event of an impact.



DANGER

Since operation of the front passenger airbag is not compatible with the position of a rear-facing child seat, **NEVER fit a rear-facing child restraint system in a seat protected by an ACTIVATED front AIRBAG. This can lead to the DEATH of the CHILD or SERIOUS INJURY.**

CHILD SAFETY: DEACTIVATING, ACTIVATING THE FRONT PASSENGER AIRBAG

2



To restart the airbag : vehicle stopped, ignition switched off, press and turn the lock to **1** position ON.

When the ignition is switched on, you **must** check that the warning light



is off and that the warning

light  comes on the display **2** after each start-up for around 60 seconds.

The front passenger airbag is activated.

Operating faults

It is forbidden to fit a rear-facing child seat to the front passenger

seat if the airbag activation/deactivation system is faulty.

Allowing any other passenger to sit in that seat is not recommended.

Contact your approved dealer as soon as possible.



The passenger airbag may only be activated or deactivated when the **vehicle is stationary with the ignition off.**

If it is interfered with when the vehicle is being driven, indicator

lights  and  will come on.

Switch the ignition off then on again to reset the airbag in accordance with the lock position.

DRIVING POSITION

Driving position: left-hand drive

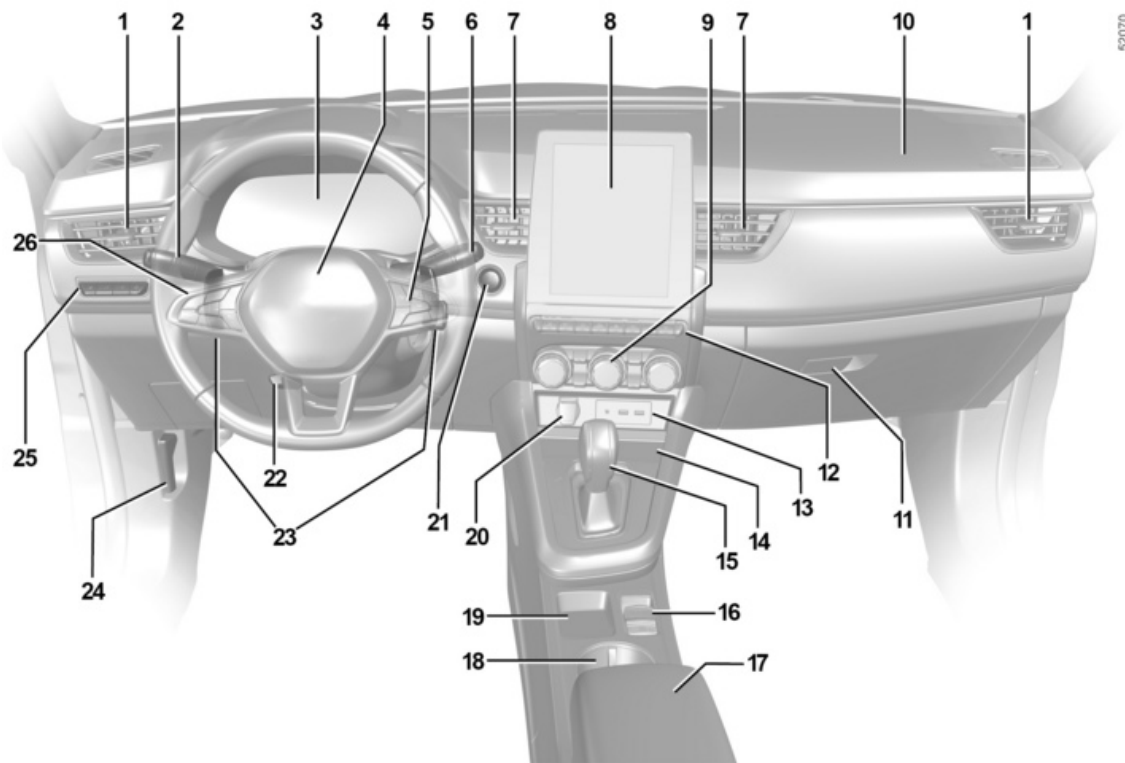

520770

DRIVING POSITION

The equipment fitted, described below, DEPENDS ON THE VERSION AND COUNTRY.

1. Side air vent.

2. Stalk for :

- direction indicator lights ;
- exterior lights ;
- rear fog lights.

3. Instrument panel.

4. Driver airbag and horn location.

5. Controls for :

- on-board computer information read-out and vehicle settings customisation menu ;
- remote radio and navigation system.

6. Steering column stalk for wind-screen wash/wiper.

7. Centre air vents.

8. Multimedia screen.

9. Heating or air conditioning controls.

10. Passenger airbag location.

11. Glove compartment.

12. Controls for :

- front seat heating/ventilating ;
- activation/deactivation of the Stop and Start function ;

- activation/deactivation, depending on the vehicle, of the ECO or MULTI-SENSE mode ;
- hazard warning lights ;
- electric door locking ;
- activation/deactivation of the parking distance control ;
- ...

13. USB sockets.

14. Charging zone/telephone storage.

15. Gearstick.

16. Controls for :

- activating/deactivating the electronic parking brake ;
- activation/deactivation of the function autohold.

17. Center armrest.

18. Cup holder.

19. "Hands-free" card storage.

20. Accessories socket.

21. Engine start/stop button.

22. Control for adjusting steering wheel height and reach.

23. Automatic gearbox paddles.

24. Bonnet release control.

25. Controls for :

- lighting rheostat for control instruments ;

- headlight beam height remote adjustment ;
- activation/deactivation of the steering wheel heating ;
- 'My Safety' function.

26. General cruise control switch/speed limiter/Stop and Go adaptive cruise control controls.

DRIVING POSITION

Driving position: right-hand drive

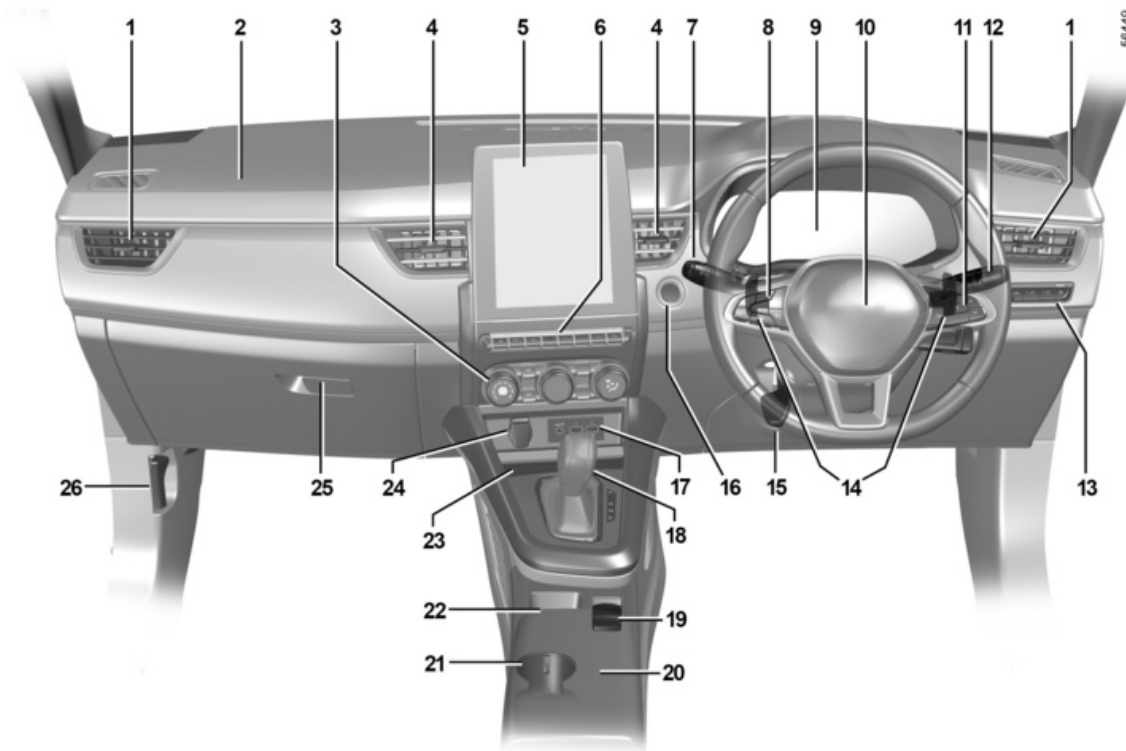

DRIVING POSITION

The equipment fitted, described below, DEPENDS ON THE VERSION AND COUNTRY.

- 1.** Side air vent.
- 2.** Passenger airbag location.
- 3.** Heating or air conditioning controls.
- 4.** Centre air vents.
- 5.** Multimedia screen.
- 6.** Controls for :
 - front seat heating/ventilating ;
 - activation/deactivation of the Stop and Start function ;
 - activation/deactivation, depending on the vehicle, of the ECO or MULTI-SENSE mode ;
 - hazard warning lights ;
 - electric door locking ;
 - activation/deactivation of the parking distance control ;
 - ...
- 7.** Stalk for :
 - direction indicator lights ;
 - exterior lights ;
 - rear fog lights.
- 8.** General cruise control switch/speed limiter/Stop and Go adaptive cruise control controls.
- 9.** Instrument panel.
- 10.** Driver airbag and horn location.

- 11.** Controls for :
 - on-board computer information read-out and vehicle settings customisation menu ;
 - remote radio and navigation system.
- 12.** Steering column stalk for windscreen and wash/wiper.
- 13.** Controls for :
 - lighting rheostat for control instruments ;
 - headlight beam height remote adjustment ;
 - activation/deactivation of the steering wheel heating ;
 - 'My Safety' function.
- 14.** Automatic gearbox paddles.
- 15.** Control for adjusting steering wheel height and reach.
- 16.** Engine start/stop button.
- 17.** USB sockets.
- 18.** Gearstick.
- 19.** Controls for :
 - activating/deactivating the electronic parking brake ;
 - activation/deactivation of the function autohold.
- 20.** Center armrest.
- 21.** Cup holder.
- 22.** "Hands-free" card storage.

- 23.** Charging zone/telephone storage.
- 24.** Accessories socket.
- 25.** Glove compartment.
- 26.** Bonnet release control.

WARNING LIGHTS

The display of information shown below **DEPENDS ON THE VEHICLE EQUIPMENT AND COUNTRY.**

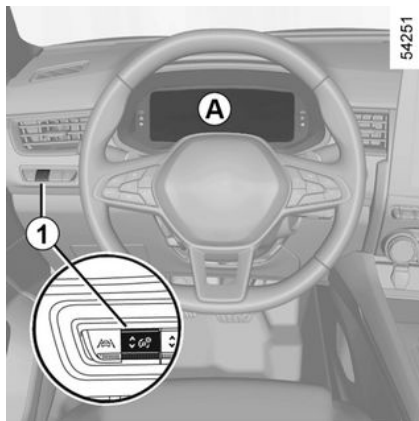

Instrument panel A or **B** : it illuminates when the ignition is switched on. Press or lift the **1** switch as many times as required to adjust the intensity.

 Warning light  means you should **drive very carefully to an approved dealer as soon as possible**. If you fail to follow this recommendation, you risk damaging your vehicle.

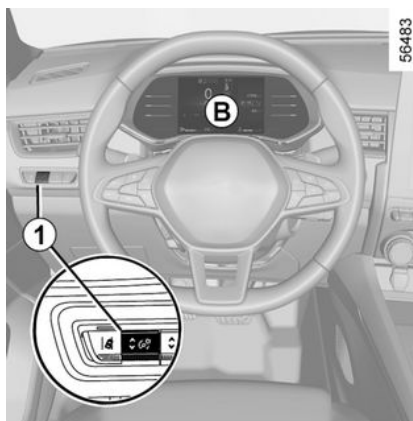

In some cases, the appearance of a warning light is accompanied by a message on the instrument panel.

 For your safety, warning light **STOP** requires you to stop immediately as soon as traffic conditions allow. Switch off the engine and do not restart it. Call an approved Dealer.

 If no lights or sounds are apparent, this indicates a fault in the instrument panel. This indicates that it is essential to stop immediately (as soon as traffic conditions allow). Ensure that the vehicle is correctly immobilised and contact an approved Dealer.

 **Side light tell-tale**

 **Main beam headlight tell-tale**

 **Dipped beam headlight tell-tale**

 **Rear fog lights tell-tale**

WARNING LIGHTS

2

 **Automatic main beam headlight indicator light** → 113

 **Left-hand direction indicator tell-tale**

 **Right-hand direction indicator tell-tale**

 **Indicator light airbag**

It lights up when the ignition or the engine is switched on and goes off after a few seconds.

If it does not come on when the ignition is switched on, or comes on when the engine is running, there is a fault in the system.

Contact your approved Dealer as soon as possible.

 **STOP warning light**

This lights up when the ignition or engine is switched on and goes out as soon as the engine is running. It comes on with other warning lights and/or messages, and is accompanied by a beep.

It requires you to stop immediately, for your own safety, as soon as traffic conditions allow. Switch off the engine and do not restart it.

Contact an approved Dealer.

 **Brake circuit fault warning light**

It lights up when the ignition or the engine is switched on and goes off after a few seconds.

If it comes on during braking and is accompanied by the  warning light and a beep, it indicates that the fluid level in the circuit is low or that there is a braking system fault.

Stop as soon as traffic conditions allow and consult an approved dealer.

 **Battery charge warning light**

It lights up when the ignition or the engine is switched on and goes off after a few seconds.

If it comes on on the road, accompanied by the  warning light and a beep, this indicates an overload or discharge in the electrical circuit.

Stop as soon as traffic conditions allow and contact an approved Dealer.

 **Oil pressure warning light**

It lights up when the ignition or the engine is switched on and goes off after a few seconds.

If it comes on on the road, accompanied by the  warning light and a beep, stop immediately and cut the ignition.

Check the oil level. If the level is normal, the warning light is related to something else.

Call an approved Dealer.

 **Power steering system warning light**

It lights up when the ignition or the engine is switched on and goes off after a few seconds.

If it comes on while driving, alongside the warning light , this means there is a system fault.

Contact an authorised dealer.

 **"AUTOHOLD" system tell-tale**
→ 149

 **Warning light**

This lights up when the ignition or engine is switched on and goes out as soon as the engine is running. It can light up in conjunction with oth-

WARNING LIGHTS

er warning lights and/or messages on the instrument panel.

It means you should **drive very carefully** to an approved dealer as soon as possible. If you fail to follow this recommendation, you risk damaging your vehicle.

Warning light

If it appears in red during driving and is accompanied by the **STOP** indicator light, you must, for your safety, stop as soon as traffic conditions allow. Switch off the engine and do not restart it. Call an approved Dealer. If it appears in yellow during driving and is accompanied by the

 warning light, visit an approved dealer as soon as possible. **Meanwhile, drive with care.** If you fail to follow this recommendation, you risk damaging your vehicle.

Electronic parking brake warning light → 146

Gear change indicator

This lights up to advise you to change to a higher gear (up arrow) or lower gear (down arrow). → 151

Warning light for the electronic stability program (ESC) and traction control system

It lights up when the ignition or the engine is switched on and goes off after a few seconds.

There are several reasons for the warning light to appear. → 163

Warning light for non-availability of the electronic stability program (ESC) and traction control system

Door status warning light

Anti-lock braking warning light

It lights up when the ignition or the engine is switched on and goes off after a few seconds.

If it lights up when you are driving, it indicates a fault in the anti-lock braking system.

Braking will then be as normal, without the ABS. Contact an approved Dealer as soon as possible.

Particle filter system warning light → 144

Tyre under-inflation warning light

It lights up when the ignition is switched on or the engine starts, then disappears after a few seconds. → 159

Toxic Fume Filter System Warning Light

On vehicles that are equipped, this light comes on when the engine is started and, depending on the vehicle, when the ignition is switched off while the engine is in the standby phase → 131 then it goes out.

- If it lights up continuously, consult your approved dealer as soon as possible ;
- If it flashes, reduce the engine speed until the light stops flashing. Contact your approved Dealer as soon as possible. → 158

Low fuel level warning light

It lights up orange when the ignition or the engine is switched on and goes off after a few seconds.

If the light becomes orange while driving and a beep sounds, fill up with fuel as soon as possible. There is only approximately 31 miles (50 km) worth of fuel left.

WARNING LIGHTS

Mode warning light ECO

It comes on when ECO mode is active. → 151

Freewheel indicator light

It is illuminated in ECO mode (or My Sense mode depending on the vehicle) when the “Freewheel in ECO mode” parameter is activated (ON) in the user settings. → 105

This warning light is displayed when the function is activated :

- in grey when the vehicle is not in freewheel mode ;
- in green or, depending on the vehicle, when the vehicle is in freewheel mode (automatic neutral).

Note : depending on the vehicle, for vehicles fitted with Multi-Sense, activation/deactivation is carried out by configuring the various My Sense mode or Eco mode. → 249

The display of information shown below DEPENDS ON THE VEHICLE EQUIPMENT AND COUNTRY.

Coolant temperature warning light

This lights up blue when you switch on the ignition or start the engine depending on the vehicle.

If it turns red, stop and let the engine idle for a minute or two.

The temperature should lower and the warning light should return to a blue colour. If not, stop the engine. Let the engine cool down before checking the coolant.

Contact an approved Dealer.

Speed limiter warning lights → 202

Cruise control warning lights → 205

Stop and Go adaptive cruise control indicator lights → 208

Engine standby warning light → 131

Unavailability of engine standby warning light → 131

Brake pedal warning light

This lights up when the brake pedal should be depressed. → 135

Assisted parking indicator → 229

Overspeed warning light → 100

Lane departure prevention warning light → 166

Lane centering system warning light → 190

(Depending on the vehicle) Indicator of failure or unavailability of active emergency braking → 178

Warning light of no presence hands on the steering wheel → 166

The presence and operation of the warning lights **DEPEND ON THE EQUIPMENT AND COUNTRY.**

Electrotechnical system warning light

It appears when the temperature of the electrical assembly is too high. Stop the vehicle without switching off the ignition. The temperature should lower and the warning light should disappear. If this is not the case, please consult an Authorised Dealer.

The warning light can be accompanied by a drop in vehicle performance.

WARNING LIGHTS



Secondary 12 V battery charge warning light

If it comes on, accompanied by the



warning light and a beep, this means that the electrical circuit is overcharged or discharged.



Traction battery fault warning light

If it appears, accompanied by the



warning light, this indicates a fault related to the operation of the traction battery. Contact your approved Dealer straight away.



Traction battery gauge indicator light

This appears in yellow when the traction battery charge level has reached the reserve threshold. → 100



The **STOP** warning light requires you to stop immediately, for your own safety, as soon as traffic conditions allow. Switch off the engine and do not restart it. Call an approved Dealer.

The presence and operation of the warning lights **DEPEND ON THE EQUIPMENT AND COUNTRY.**



Electric operating mode warning light

It is displayed when only the electric motor and traction battery are powering the movement of the vehicle.

→ 100



Electric motor fault warning light

When it comes on, this indicates an electrotechnical fault related to the electrical assembly (traction battery and electric motor). Contact your approved Dealer straight away.



Electric motor fault warning light

When it comes on, this indicates a fault with the electrotechnical system linked to the electric motor. Contact your approved Dealer straight away.



If no lights or sounds are apparent, this indicates a fault in the instrument panel. This indicates that it is essential to stop immediately (as soon as traffic conditions allow). Ensure that the vehicle is correctly immobilised and contact an approved Dealer.

WARNING LIGHTS

2



On display *D*

 Passenger Airbag ON → 78

 Passenger Airbag OFF → 78

 Seat belt reminder warning
lights → 50

TRIP COMPUTER

General information

Trip computer and warning system A or B

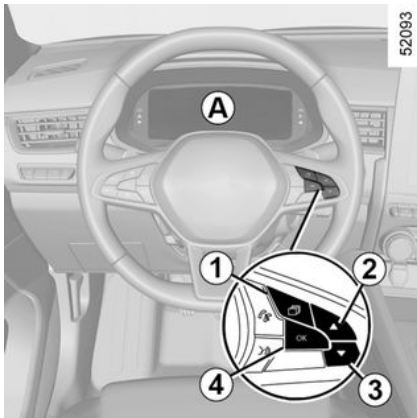

Depending on the vehicle, this includes the following functions:

- distance travelled;
- journey settings;
- information messages;
- operating fault messages (con-

nected to the  warning light);

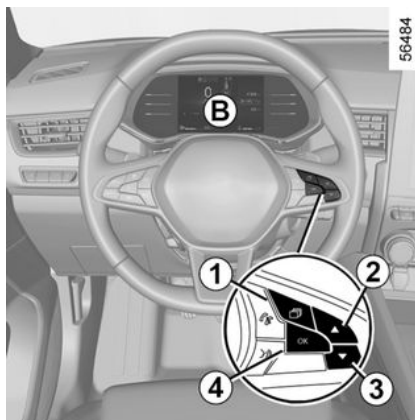

- warning messages (connected to the **STOP** warning light);
- vehicle settings customisation menu. → 105



Vehicle fitted with A instrument panel

The functions will be distributed in zones **5** and **6**. The location of the zones differs depending on the style selected.

Press the **1** switch to browse between menus and select functions by repeatedly pressing switch **2** or **3**, then if necessary use the **4** switch to confirm "OK".

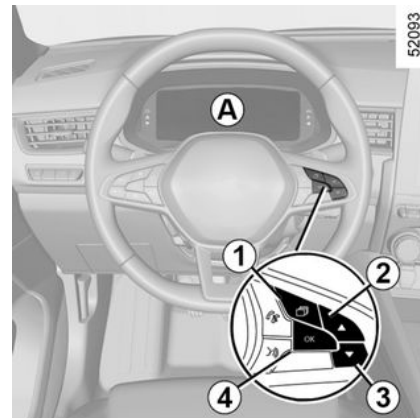

2

TRIP COMPUTER

2

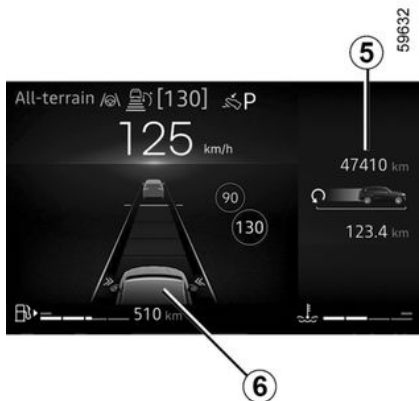

Vehicle fitted with *B* instrument panel

The function will be distributed in zones **5** and **6**.

Press switch **1** to browse between the zones and select the functions by repeatedly pressing switch **2** or **3**.

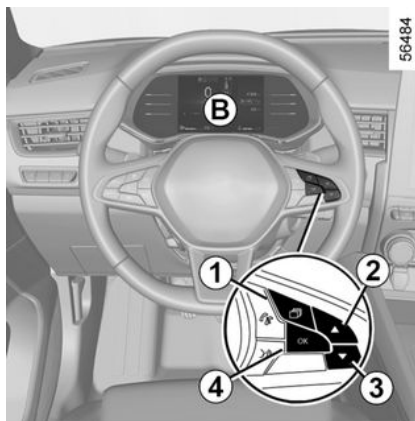

Selections

(the display depends on the vehicle equipment and country)

- a) Trip log, operating faults and information message readout;
- b) current fuel consumption and average fuel consumption;
- c) trip mileage recorder and average speed;
- d) Reset the tyre pressure;
- e) set the time;
- f) distance before service;
 - Distance before service;
 - Distance before oil change;

Resetting the trip mileage recorder and journey parameters (reset button)

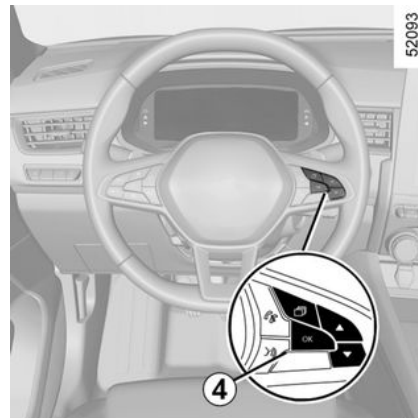

With one of the trip parameters selected as the display, press and hold the **4** switch "OK" until the display resets to zero.

Automatic resetting of the journey parameters

Resetting occurs automatically when the maximum value of any of the parameters is exceeded.

Interpreting some of the values displayed after resetting

The values showing average fuel consumption, range and average

TRIP COMPUTER

speed will become more stable and reliable the further you travel after pressing the reset button.

For the first few miles after pressing the reset key you will notice that the range increases as you travel. This range takes into account the average fuel consumption since the last time the reset button was pressed. Therefore, the average fuel consumption may decrease when :





- the vehicle stops accelerating ;
- the engine reaches its operating temperature (if the engine was cold when the reset key was pressed) ;
- when driving from an urban area onto the open road.

TRIP COMPUTER

Journey parameters

2

The display of information shown below **DEPENDS ON THE VEHICLE EQUIPMENT AND COUNTRY.**

Examples of selections	Interpreting the display selected
Vehicle Systems OK	a) Trip log. Successive display : <ul style="list-style-type: none">- information messages (passenger airbag OFF etc.);- operating fault messages ("Check injection" etc.).
 7.4 L/100	b) Current fuel consumption. This value is displayed after a speed of approximately 20 mph (30 km/h) is reached.
 5.8 L/100	Average fuel consumption since the last reset. The value is displayed after having travelled at least 400 metres since the last reset.
 112,4 km	c) Mileage recorder : Distance travelled since the last reset.
 123.4 km/h	Average speed since the last reset. The value is displayed after driving 400 metres.
Adjust tyre pressure [press and hold]	d) Reset the tyre pressure. ➔ 159
16 :30	e) Setting the time.

TRIP COMPUTER

Examples of selections	Interpreting the display selected
	→ 107

Examples of selections	Interpreting the display selected
<p>On-board computer with mileage-before-service message</p>	
<p>Service in 30 000 km / 12 months</p>	<p>f) Service distance. Mileage before service</p> <p>With the ignition on and engine not running, access the "Mileage before service" information. When the distance value approaches its limit, there are several possible scenarios :</p> <ul style="list-style-type: none"> - If the range is less than 930 miles (1,500 km) or one month : the message "Service due" is displayed accompanied by the nearest term (distance or time) ; - range equal to 0 miles (0 km) or date of service reached : the message "Service Required" is displayed accompanied by the warning light  . <p>The vehicle requires a service as soon as possible.</p>
<p>Service due in 300 km / 24 days</p>	
<p>Service Required</p>	
<p>Reset : to reset the distance before the next service, press and hold button OK for approximately 10 seconds until the display shows the mileage before service permanently.</p> <p>NB : if a service is performed without changing the engine oil, only the mileage before the next service should be reset. In the event of an oil change, both the distance before the next service and the next oil change should be reset.</p>	
<p>Oil change in 30 000 km / 24 months</p>	<p>f) Service distance. Mileage before service</p>

TRIP COMPUTER

2

Examples of selections	Interpreting the display selected
On-board computer with mileage-before-service message	
	<p>With the ignition on and the engine not running, access the mileage information to display the mileage before the next oil change.</p> <p>Depending on the vehicle, the mileage before an oil change varies according to the driving style (frequent driving at low speed, door-to-door journeys, extensive use at idling speed, towing a trailer, etc.). The distance remaining until the next oil change can therefore decrease more quickly in some cases than the actual distance travelled.</p> <p>Reset : to reset the distance before the next service, press and hold button OK for approximately 10 seconds until the display shows the mileage before oil change permanently.</p> <p>NB : if a service is performed without changing the engine oil, only the mileage before the next service should be reset. In the event of an oil change, both the distance before the next service and the next oil change should be reset.</p>

TRIP COMPUTER

Information messages

These can help in the vehicle starting phase, or give information about a selection or a driving status.

Examples of information messages are given below.

Examples of messages	Interpreting the display selected
"Parking Brake ON"	Indicates that the parking brake has been applied.
"Turn steering wheel + START"	Turn the steering wheel slightly whilst pressing the vehicle start button to unlock the steering column.
"Vehicle Checks in Progress"	Displayed with the ignition on when the vehicle is running self-diagnostics.

TRIP COMPUTER

Operating fault messages

2

These appear with the  warning light and mean that you should drive very carefully to an authorised dealer as soon as possible. If you fail to follow this recommendation, you risk damaging your vehicle.

They disappear when the display selection key is pressed or after several seconds and are stored in the computer log.

The  warning light stays on. Examples of operating fault messages are given below.

Examples of messages	Interpreting the display selected
"Check vehicle"	Indicates a fault in one of the pedal sensors, battery management system or oil level sensor.
"WARNING : Check Airbag"	Indicates a fault in the restraint system in addition to the seat belts. In the event of an accident, it is possible that they may not be triggered.
« Check Electric System »	Indicates a fault in the traction system.

TRIP COMPUTER

Warning messages

These appear with the **STOP** warning light and require you to stop immediately, for your own safety, as soon as traffic conditions allow. Stop your engine and do not restart it. Contact an approved Dealer.

Examples of warning messages are given below. **Note** : the messages appear on the display either individually or alternately (when there are several messages to be displayed), and may be accompanied by a warning light and/or a beep.

Examples of messages	Interpreting the display selected
"WARNING : Engine Failure Risk"	Indicates an injection fault, the vehicle's engine has overheated or there is a serious engine fault.
"WARNING : Braking System"	Indicates a fault in the braking system.
"WARNING : Electric System"	Indicates a fault in the vehicle battery charging circuit (alternator etc.).
"Puncture"	Indicates that at least one wheel is punctured or severely underinflated.
« Electric motor failure »	Indicates that the vehicle is losing power.
« Check Electric System »	Indicates a fault in the electric system.

TRIP COMPUTER

Displays and indicators

2 Engine oil level low warning



When the engine is started, the instrument panel display alerts you if the minimum oil level is reached.

→ 281

The first time the warning appears, it can be cleared by pressing **1** "OK".

Subsequent warnings will disappear automatically after around 30 seconds.

Instrument panel in miles



(option to switch to km/h)

Vehicles not fitted with a multimedia screen

- With the ignition off, press the **2** switch as many times as required to reach the setting **5** ;
- press **3** or **4** repeatedly to access "Settings", then press **1** OK ;
- repeat the same operation to access "DASHBOARD", then "Units".

Vehicles fitted with a multimedia screen.

Please refer to the multimedia instructions to select the audio system.

Note : in both cases, once the battery is switched off, the on-board computer automatically returns to the original unit of measurement.

To return to the previous mode, repeat the same operation.

Please refer to the multimedia instructions for more information.

Instrument panel A



It lights up when the ignition is switched on. In some cases, the appearance of a warning light is accompanied by a message.

Depending on the vehicle, you can customise your instrument panel with the content and colours of your choice.

TRIP COMPUTER

For vehicles fitted with a multimedia screen, refer to the multimedia instructions.

For vehicles not fitted with a multimedia screen → 105.



Speedometer 6

Multimedia information 7

Depending on the vehicle, you can display information from the multimedia screen (the compass, telephone, navigation, etc.).

Please refer to the multimedia instructions for more information.

Rev counter 8

(graduations x 1000)

Depending on the selected customisation, it may not be displayed.

Overspeed buzzer

Depending on the vehicle and country, the  warning light is displayed and a beep sounds. This beep sounds as soon as the vehicle is travelling at over 75 mph (120 km/h). This warning light remains lit for as long

as the vehicle is travelling at over 74 mph (120 km/h).

Driving style indicator 9 → 151

Coolant temperature indicator 11

In normal use, indicator 11 should be before area 10. Under "intensive" operating conditions, the needle may approach this zone. This is not serious unless the warning light

STOP comes on accompanied by a message on the instrument panel and a beep.

Estimated mileage with remaining fuel 12

The value is displayed after driving 400 metres.

Fuel gauge 13

If the level is at the minimum, warn-

ing light  integrated in the indicator comes on orange, accompanied by a beep. Fill up as soon as possible.

Instrument panel B

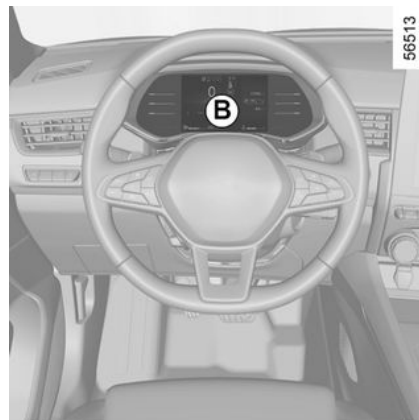

It lights up when the ignition is switched on. In some cases, the appearance of a warning light is accompanied by a message.

Depending on the vehicle, you can customise your instrument panel with the contents and colours of your choice. For vehicles fitted with a multimedia screen, refer to the multimedia instructions.

For vehicles not fitted with a navigation system → 105

TRIP COMPUTER

2

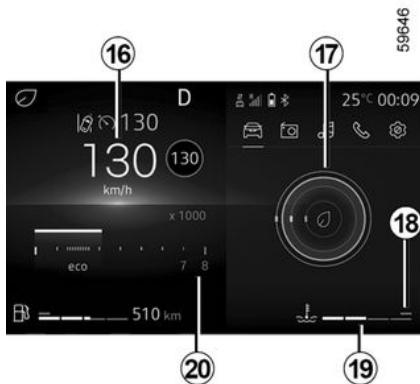

Overspeed buzzer

Depending on the vehicle and country,

the  warning light is displayed and a beep sounds. This beep sounds as soon as the vehicle is travelling at over 75 mph (120 km/h). This warning light remains lit for as long as the vehicle is travelling at over 74 mph (120 km/h).

Speedometer 16

Depending on the style selected, the display varies.

Driving style indicator 17 → 151

Coolant temperature indicator 19

In normal use, the indicator 19 should be before area 18.



Under "intensive" operating conditions, the needle may approach this zone. This is not serious unless the

warning light  comes on accompanied by a message on the instrument panel and a beep.

Rev counter 20

(graduations x 1000)

This is displayed differently according to how the instrument panel is customised. Depending on the style selected, the display varies.

Driving mode selected 21 → 249

Total mileage recorder 22 → 94

Trip computer zone 23 → 91

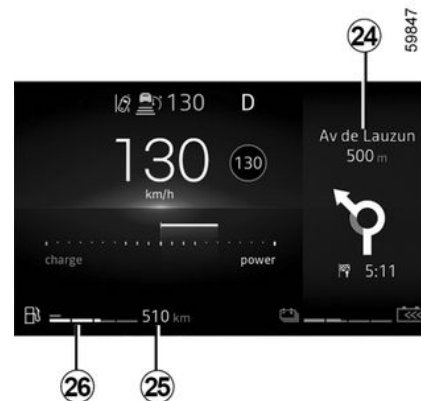

Multimedia information 24

Depending on the vehicle, you can display information from the multimedia screen (the compass, telephone, navigation, etc.).

Please refer to the multimedia instructions for more information.

Estimated mileage with remaining fuel 25

The value is displayed after driving 400 metres. → 94

TRIP COMPUTER

59648

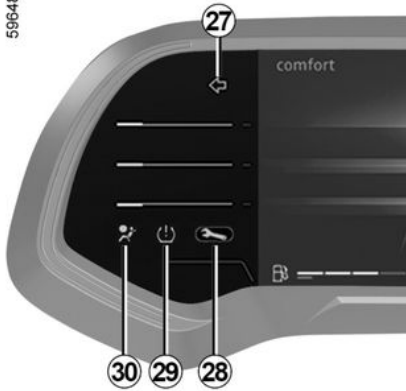

Fuel gauge 26

If the level is at the minimum, warn-

ing light  integrated in the indicator comes on orange, accompanied by a beep. Fill up as soon as possible.

Direction indicators 27

Warning light 28 → 85

Tyre under-inflation warning light 29 → 159

Airbag warning light 30 → 54

59697

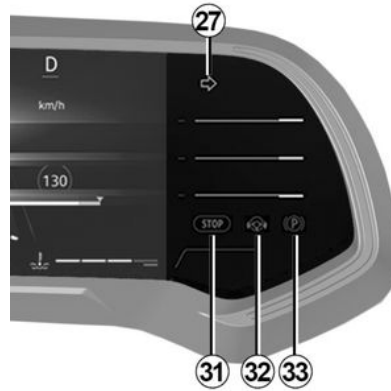

Urgent stop warning light 31 → 85

Hands off steering wheel warning light 32 → 166 → 190

Parking brake or Electronic parking brake warning light 33 → 146

Special features of the E-Tech full hybrid version

lights up when the driver's door is opened.

In some cases, the appearance of a warning light is accompanied by a message.

Note : all display and indicators location differs depending on the vehicle.

"230 V" traction battery level remaining 3

Traction battery level low

In the event of extreme use at low speed, the traction battery charge level may reach a low level.

The **4** warning light appears in yellow to warn you.

The electric motor performance will be limited to ensure that the hybrid system operates correctly, until the battery charge level reaches a sufficient level.

Opt for a smoother driving style or, if possible, stop the vehicle without switching off the ignition until the **4** warning light appears in blue once again.

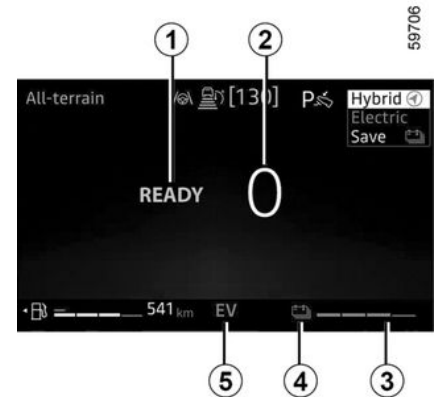

2

TRIP COMPUTER

Immobilisation threshold imminent

In the event of extreme and prolonged use of the vehicle (e.g. towing or driving in steep off-road conditions) at speeds below 6 mph (10 km/h), the charge level may reach the threshold for imminent immobilisation.

A beep sounds and the warning light



appears in red.

If the charge level continues to drop, the electric range value will no longer be displayed.

If possible, stop the vehicle when traffic conditions allow it.

Leave the combustion engine on until the warning lights disappear.

This must be done to recharge the traction battery.

Electric operating mode warning light 5

It is displayed when only the traction battery is powering movement of the vehicle.

Message indicating vehicle ready for driving 1

The message READY appears when the ignition is switched-on and disappears when the vehicle speed exceeds 3 mph (5 km/h).

Speedometer 2

Depending on the style selected, the display varies.



Energy flow indicator 6 → 0

Charge meter 7 → 151

Driving mode selected 8 → 249

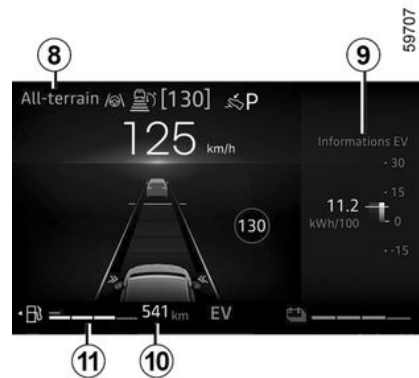

Trip computer zone or multimedia information 9

Depending on the vehicle, you can display trip computer or information from the multimedia screen (the compass, telephone, navigation etc.).

Please refer to the multimedia instructions for further information.

Estimated mileage with remaining fuel 10

The value is displayed after driving 400 meters. → 94

Fuel gauge 11

If the level is at the minimum, warning light  integrated in the indi-

TRIP COMPUTER

cator comes on orange, accompanied by a beep.

Whatever the remaining battery level, fill the tank as soon as possible.

If the vehicle runs completely out of fuel, fill the tank with at least 1.76 gal (8 litres) of fuel.

Otherwise the hybrid mode will remain unavailable.

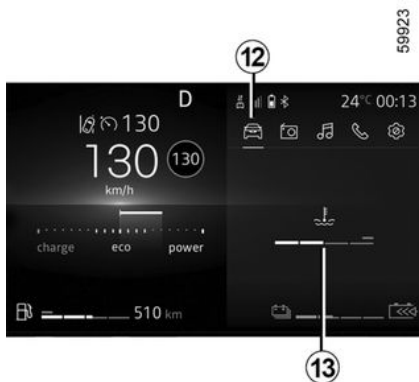

Combustion engine temperature display 13

Press the switch 14 to access the "Vehicle" 12, then press the switch 15 or 16 switch until 13 is displayed.

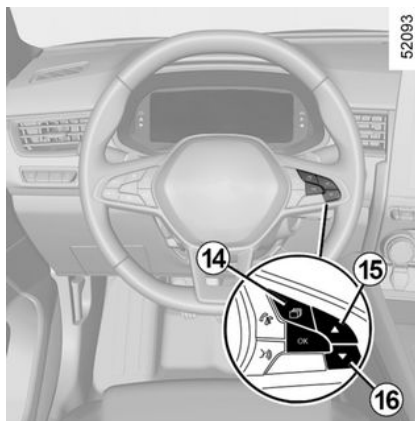

Vehicle settings customisation menu

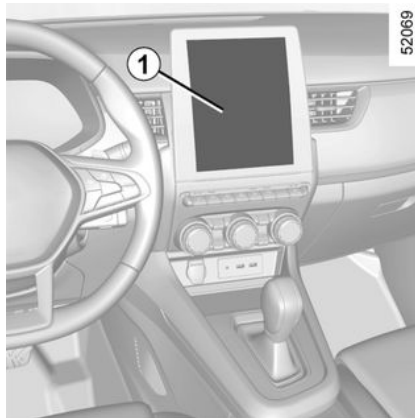

Depending on the vehicle equipment, this function allows you to activate/deactivate and adjust some of the vehicle's functions.

Vehicles fitted with a multimedia screen 1

Accessing the settings menu

Refer to the various multimedia instructions for information on accessing the settings.

Adjusting the settings

Select a menu then the function to be modified (the display depends on the vehicle equipment and country):

a) "Driving":

- Indicator volume;
- Free wheel in ECO mode.

b) "Access":

- Unlock driver's door only;
- Lock doors during driving;
- Opening/closing in hands-free mode;
- Remote locking/Approach unlocking;
- Silent mode;
- Automatic locking.

c) "Wiping and lighting":

- Wiping in reverse;
- Automatic front wiping;
- Wiping after washing.

d) "Welcome":

TRIP COMPUTER

- External welcome ;
- Automatic fold-out of mirrors ;
- Interior welcome ;
- Courtesy light auto mode.

Depending on the function, select :

- "ON" or "OFF" to activate or deactivate,

or

- a duration to adjust the time the lights are switched on (for the "Follow-me home lighting" function for example).

Please refer to the multimedia instructions for further information.



For safety reasons, carry out any adjustments when the vehicle is not being driven.

Vehicles not fitted with a multimedia screen

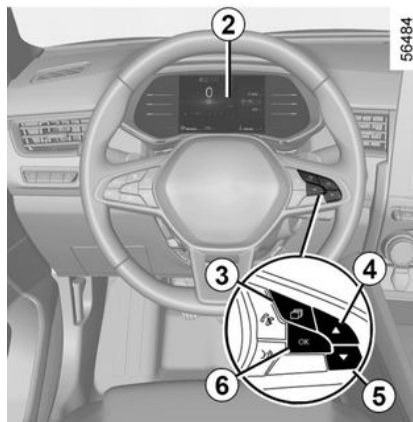

Accessing the settings menu on display 2

With the vehicle stopped, press the **3** switch as many times as required to reach the "Vehicle" tab ; Press repeatedly on the **4** or **5** switch to access the "Settings" menu, then confirm by pressing **6** "OK".

Adjusting the settings

Navigate using the **4** or **5** control to select the function to be modified and press **6** "OK" to confirm (display may vary according to vehicle equipment and country) :

a)"DASHBOARD" :

- Language ;
- Unit ;
- Style ;
- Colour.

b)"VEHICLE" :

- Rear windscreen wiping in reverse gear ;
- Automatic windscreen wiping ;
- Front/rear drip wiping function ;
- Free wheel in ECO mode ;
- External welcome.

c)"PARKING ASSIST" :

- Beep sound volume.

d)"DRIVING ASSIST" :

- Lane departure sensitivity ;
- Lane departure vibration ;
- Lane keeping sensitivity ;
- Blind spot warning ;
- Active braking ;
- Overspeed warning ;
- Distance warning.

e)"LIGHTING" :

- Courtesy light auto mode.

f)"ACCESS" :

- Lock doors during driving ;
- Opening/closing in hands-free mode ;
- Unlock the driver's door only ;
- Automatic re-locking ;
- Silent locking ;
- Automatic opening/closing ;
- Automatic fold-out of mirrors.

TRIP COMPUTER

g) "RESET".

function activated

function deactivated



Once a line has been selected, press **6** "OK" to adjust the function.

If you select either "PARKING ASSIST" then "VOLUME", or "DASHBOARD" then "LANGUAGE", you will have to make a further selection (sound volume of the parking distance control or instrument panel language). In this case, make your selection and confirm it by pressing **6** "OK", the selected value is shown

by a in front of the line.

To exit the menu, press **4** or **5** to access "BACK" and confirm by pressing **6** "OK". It may be necessary to carry out this operation more than once.

 The vehicle settings personalisation menu cannot be used when driving. At a speed exceeding 12 mph (20 km/h), the instrument panel display switches automatically back to trip computer and warning system mode.

Clock and outdoor temperature

Vehicles fitted with a multimedia screen

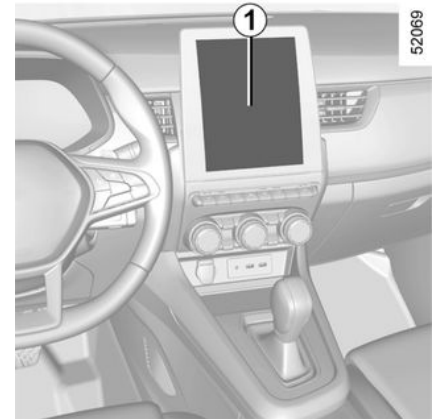

The time and exterior temperature are displayed on the multimedia screen **1**.

Refer to the multimedia instructions.

TRIP COMPUTER

Vehicles not fitted with a multi-media screen

2



Press the **2** switch as many times as required to reach the "Settings".

Repeatedly press control **3** or **4** to reach the "Time setting" menu then press **5** "OK".

Press and hold switch **5** "OK" until the time display flashes.

Set the time using control **3** or **4**, then press switch **5** "OK" to confirm.

Set the minutes using control **3** or **4**, then press switch **5** "OK" to confirm.



Depending on the vehicle, If the electrical supply is cut (battery disconnected, broken supply wire, etc.), the clock will automatically go back to the right time after a few minutes once the system is capable of receiving information GPS.

External temperature indicator

Special note :

When the external temperature is between -3°C and $+3^{\circ}\text{C}$, the $^{\circ}\text{C}$ figures flash (indicates risk of ice).



External temperature indicator

As ice formation is related to climatic exposure, local air humidity and temperature, the external temperature alone is not sufficient to detect ice.

STEERING

Adjusting the steering wheel height and depth

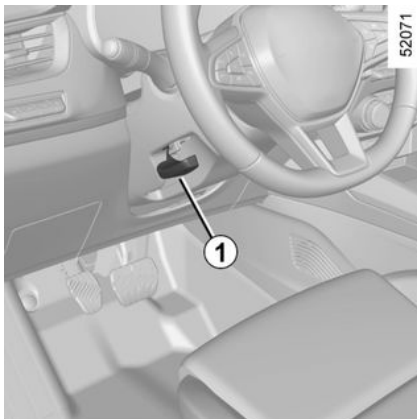

Lower the lever **1** and position the steering wheel in the required position.

Then, raise the lever fully, beyond the point of resistance to lock the steering wheel.

Make sure that the steering wheel is correctly locked.



For safety reasons, only adjust the steering wheel when the vehicle is stationary.

Steering wheel heating



(depending on vehicle)

This function heats the steering wheel **2**.

Operating principle

When the temperature is reached, the function regulates the temperature of the heated areas for approximately 30 minutes and then switches off automatically.

Activating the function

With the ignition on, press the switch **3**, the warning light integrated in the switch lights up.

Deactivating the function

- Automatic:

The function switches off automatically after the regulation phase of approximately 30 minutes. The warning light integrated in the switch **3** remains on.

Note: if the function has switched off automatically, press the switch **3** twice to reactivate it.

If switch **3** is not pressed again, the function will be reactivated the next time the ignition is switched on.

- Manually:

To deactivate the function during the regulation phase, press the switch **3**. The indicator light in the switch **3** goes out.

Power-assisted steering

Never drive with an inadequately charged battery.

Speed sensitive power steering

The speed sensitive power steering system is equipped with an electronic control system which alters the

STEERING

level of assistance to suit the vehicle speed.

Steering is made easier during parking manoeuvres (for added comfort) while the force needed to steer increases progressively as the speed rises (for enhanced safety at high speeds).

Special feature of Stop and Start

With the engine on standby, power-assisted steering is no longer operational. In this case, it returns to its original state when the engine is restarted or when the speed exceeds 1 mph (1 km/h) (hill, slope etc.).

Note : the power-assisted steering sense depends on the driving mode selected in the "MULTI-SENSE" menu. → 249



Never leave the steering wheel on full lock when the vehicle is stationary.



With the engine switched off, or if there is a system fault, it is still possible to turn the steering wheel. The force required will be greater.



Never switch off the ignition when travelling downhill, and avoid doing so in normal driving (assistance is not provided).

REAR VIEW

Door mirrors

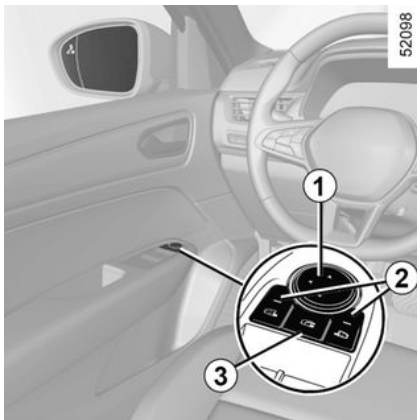

Adjustment

When you select the door mirror using the **2** switch, the built-in warning light on the switch will appear. Then use the **1** button to adjust it to the desired position.

Heated door mirrors

Mirror de-icing is carried out at the same time as rear screen de-icing. **→ 253 → 255**.

Folding door mirrors

The door mirrors will fold-out automatically when the vehicle is unlocked. The door mirrors fold in when the vehicle is locked.

In any case, you can make the door mirrors fold in or fold out by pressing the **3** switch.

Note: you can disable/activate automatic folding of the door mirrors **→ 105**.

Special case

When the rear view mirror has been manually deployed or folded back, it is possible to reset it to a usage position.

To do this, press the **3** switch. A mechanical tapping noise can be heard from the door mirror.

If a tapping noise cannot be heard, press once again on **3** switch until the tapping noise can be heard from the door mirror.



For safety reasons, carry out any adjustments when the vehicle is not being driven.



Objects observed in the rear view mirror glass are actually closer than they appear.

For your safety, take this into account in order to correctly assess the distance before any manoeuvre.

Interior rear view mirror

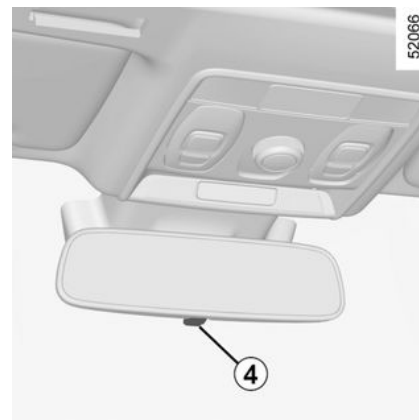

Its position can be adjusted.

Rear view mirror with lever **4**

When driving at night, to avoid being dazzled by the headlights of the ve-

REAR VIEW

hicle behind, depress the little lever located behind rear view mirror **4**.

Rear view mirror without lever 4

The rear view mirror automatically darkens when you are being followed by a vehicle which illuminates you or in very bright lighting.



For safety reasons, carry out any adjustments when the vehicle is not being driven.



Objects observed in the rear view mirror glass are actually closer than they appear.

For your safety, take this into account in order to correctly assess the distance before any manoeuvre.

LIGHTING AND SIGNALS

Exterior lighting and signals



Side lights

 Turn ring **2** until the symbol is opposite mark **3**.

This indicator light on the instrument panel comes on.

Daytime running lights function

The daytime running lights come on automatically with no action on stalk **1** when the engine is started, and they go off once the engine is switched off.



Dipped beam headlights

Manual operation

Turn ring **2** until the symbol is opposite mark **3**. This indicator light on the instrument panel comes on.

Automatic operation

(depending on the vehicle)

Turn ring **2** until the AUTO symbol is opposite mark **3**: with the engine running, the dipped beam headlights switch on or off automatically depending on the brightness of the light outside, without any action on stalk **1**.

Depending on the vehicle, the dipped beam headlights will appear automatically after several sweeps of the windscreen wiper blades.



Before driving at night, check that the electrical equipment is operating correctly and adjust the headlight beams (if your vehicle is not carrying its normal load). → 117. As a general precaution, check that the lights are not obscured (by dirt, mud, snow or objects being transported).

2

LIGHTING AND SIGNALS

2



52955

During deactivation of the main beam headlights, the dipped beam headlights return to their original position.

Automatic main beam headlights

 Depending on the vehicle, this system switches the main beam headlights on and off automatically. It uses a camera located behind the interior rear-view mirror to detect vehicles that are being followed and those coming in the opposite direction.

Main beam headlights

 With the engine running and the dipped beam headlights lit, push stalk **1**. This indicator light on the instrument panel comes on.

To return to the dipped headlight position, pull stalk **1** towards you again.

“Raise lights during driving” function

When the main beam headlights are activated, the “Raise lights during driving” function improves driver visibility by automatically raising the dipped beam headlight and the main beam headlights.

 The system may encounter difficulties under certain conditions, including:

ing:

- extreme weather conditions (rain, snow, fog, etc.);
- obstruction in front of the windscreen or camera;
- when a following or oncoming vehicle has weak or hidden lighting;
- incorrect settings for the front headlights;
- reflective systems;
- ...

The main beam headlights come on automatically if:

- exterior light is weak;
- no other vehicles or lighting are detected;
- the vehicle speed is above approximately 25 mph (40 km/h).

If any of the above conditions are not fulfilled, the system switches to dipped beam headlights.

Note: make sure the windscreen is not obscured (dirt, mud, snow, condensation etc.).

LIGHTING AND SIGNALS

To activate automatic main beam headlights:

- turn ring **2** until the AUTO symbol appears opposite mark **3**.

Warning light  comes on the instrument panel.

To deactivate automatic main beam headlights:

- Turn ring **2** to a position other than AUTO;

Warning light  goes out on the instrument panel.



Automatic main beam headlights (continued)

Operating faults

When the message “Check Automatic Lighting” appears on the instrument panel, the system is deactivated.

Consult an approved dealer.



Using the portable navigation system at night in the windscreen area below the camera may disturb the operation of the “automatic main beam headlights” system (risk of reflection on the windscreen).



The “automatic main beam headlights” system should under no circumstances be used to replace driver attention and responsibility with regard to vehicle lighting and adapting to light, visibility and traffic conditions.

Switching off the lights

Depending on the vehicle:

- the lights will go out automatically when the engine is switched off, the driver's door is opened or the vehicle is locked. In this case, the next time the engine is started the lights will be switched back on according to the position of the ring **2**.

Note: if the fog lights are lit, the lights are not switched off automatically.

Lights-on reminder buzzer

If the lights are on after the engine is switched off, a warning beep sounds when the driver's door is opened to warn you that the lights are still on.

Operating faults

If the “Check lighting” message ap-

pears with the  warning light

and the  warning light flashes on the instrument panel, this indicates a lighting fault.

Consult an authorised dealer.

2

LIGHTING AND SIGNALS

Welcome and goodbye function

2



(depending on the vehicle)

Once the function is activated, the daytime running lights and the rear side lights will light up automatically upon detection of the card or when the vehicle is unlocked.

They switch off automatically :

- approximately one minute after lighting up ;
 - when starting the engine based on the position of the lighting stalk ;
- or
- upon locking the vehicle.



Activating/deactivating the function

For activation or deactivation of the external reception, refer to the multi-media manual.

Select "ON" or "OFF".

"Follow-me-home lighting" function

This function enables you to briefly switch on the side lights and dipped beam headlights (e.g. to provide light when opening a gate).

With the engine and lights switched off, the **2** ring in AUTO position (or, depending on the vehicle, in 0 position) pull the stalk **1** towards you : the side lights and dipped beam headlights will switch on for approximately 30 seconds along with the  and  warning lights on the instrument panel.

To increase this duration, you may pull the stalk up to four times (total time restricted to approximately two minutes).

On the instrument panel, the message "lighting on _ _ _" followed by the remaining time will appear as confirmation. You can then lock your vehicle.

To switch off the lights before they switch off automatically, turn the **2** ring to any position then return it to AUTO position (or, depending on the vehicle, to 0 position).

Front fog lights (including cornering function)

 (depending on the vehicle)

Turn the centre ring **4** on the stalk **1** until the symbol faces mark **3**, then release it.

Operation of the fog lights depends on the exterior lighting selected, and an indicator light will light up on the instrument panel.



LIGHTING AND SIGNALS

Rear fog lights

 Turn centre ring **4** on the stalk until the symbol faces mark **3**, then release it.

Operation of the fog lights depends on the exterior lighting selected, and an indicator light will light up on the instrument panel.

Do not forget to switch off the fog lights when they are no longer needed, to avoid inconveniencing other road users.

Switching off the lights

Turn the ring **4** again until the mark **3** is opposite the symbol for the fog light that you wish to switch off. The corresponding indicator light on the instrument panel goes out.

The front and rear fog lights switch off when the exterior lights are switched off.

 When driving in fog or snow, or when transporting objects which are higher than the roof, the fog lights do not come on automatically. Switching on the fog lights remains the responsibility of the driver: the indicator lights on the instrument panel inform you whether the fog lights are lit (indicator light on) or not (indicator light not on).

Cornering function

(depending on vehicle)

Driving in forward gear at a speed below approximately 25 mph (40 km/h), with dipped beam headlights on and under certain conditions (the angle of the steering wheel, the indicator lights on etc.), when taking a corner one of the front fog lights (cornering function) will switch on to light the inside of the bend.

When reverse gear is engaged with the dipped beam headlights on: the two front fog lights (cornering function) illuminate automatically.

Note: when shifting from reverse gear into forward gear (e.g. during a parking manoeuvre), the two fog lights (cornering function) remain lit until the vehicle speed exceeds approximately 6 mph (10 km/h).

Headlight beam adjustment

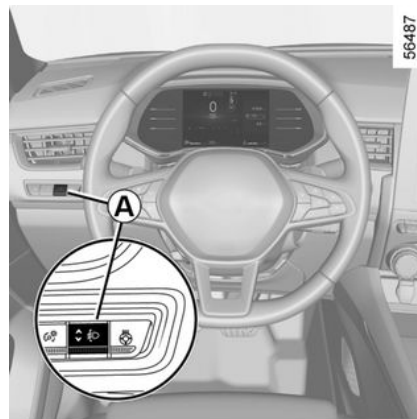

Switch **A** is used to adjust the height of the headlight beams according to the load.

With the dipped beam headlights lit, press or lift switch **A** as many times as is necessary to select the required position on the instrument panel.

Note: depending on the vehicle, at each engine start-up the position se-

LIGHTING AND SIGNALS

lected is displayed on the instrument panel for approximately 30 seconds and 5 seconds after each press of switch **A**.

Examples of position:

Thermal vehicle

0 Driver alone or with a front passenger

1 All the seats are occupied

2 or 3* Driver with passengers and luggage (or load) reaching the maximum permissible all-up weight

4 Driver without passengers and luggage (or load) reaching the maximum permissible all-up weight

* depending on the vehicle

Hybrid vehicle

0 Driver alone or with a front passenger

1 All the seats are occupied

1 or 2 Driver with passengers and luggage (or load) reaching the maximum permissible all-up weight

2 or 3 Driver without passengers and luggage (or load) reaching the maximum permissible all-up weight

This gives some examples. In all cases, adjust control **A** according to the vehicle load so that the road can be seen and other drivers are not dazzled.

AUDIBLE AND VISUAL SIGNALS

Horn

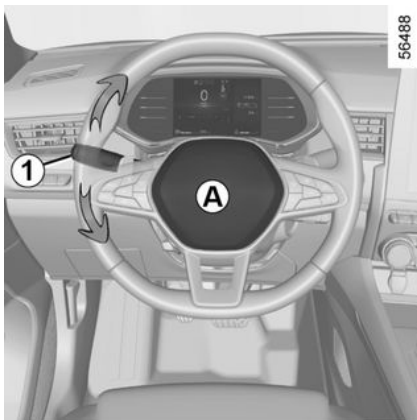

Press the steering wheel boss **A** to activate the horn.

Headlight flasher

Pull stalk **1** towards you then release it to flash the headlights.

Direction indicators

Move the stalk **1** in the same direction as you want to move the steering wheel.

One-touch mode

Briefly shift the stalk **1** upwards or downwards, not exceeding the point of resistance, then release it: the

stalk will return to its original position and the direction indicator light concerned will flash three times.

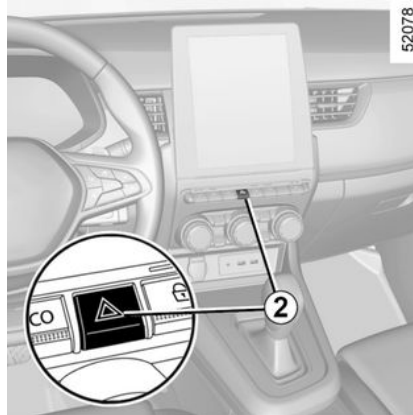

Hazard warning lights

 Press switch **2**.

This switch activates all four direction indicators and the side indicator lights simultaneously. It must only be used in an emergency to warn drivers of other vehicles that you have had to stop in an area where stopping is prohibited or unexpected, or that you are obliged to drive under special conditions.

Depending on the vehicle, the hazard warning lights may come on au-

tomatically under heavy deceleration. You can switch them off by pressing switch **2** once.

WIPER

Vehicle fitted with intermittent windscreen wipers

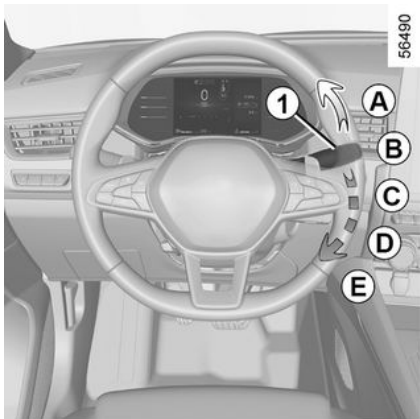

A single sweep

A short push will trigger one sweep of the wipers.

B stop

C intermittent wiping

The wipers will pause for several seconds between sweeps. It is possible to change the time between sweeps by turning ring 2.

D slow continuous wiping

E fast continuous wiping

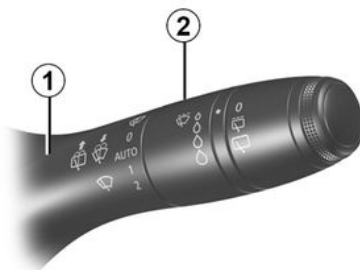

Special note

When driving the vehicle, the wiping speed slows down whenever the vehicle stops. For example, fast wiping speed will slow to normal wiping speed. As soon as the vehicle moves off, wiping will return to the speed originally selected.

If stalk 1 is operated, it overrides and cancels the automatic function.

Vehicle fitted with front windscreen wiper rain sensor

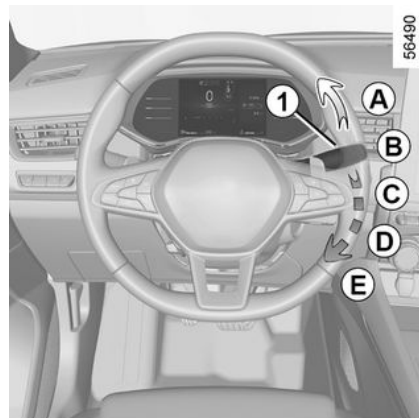

The rain sensor is located on the windscreen, in front of the interior rear-view mirror.

A single sweep

A short push will trigger one sweep of the wipers.

B stop

WIPER

45653

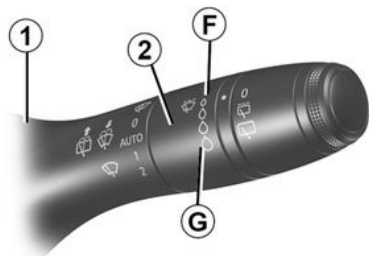

C automatic wiper function

When this position is selected, the system detects water on the windscreen and triggers the wipers at a suitable wiping speed. It is possible to change the triggering threshold and the time sweeps by turning ring **2**:

- **F** :minimum sensitivity
- **G** :maximum sensitivity

The higher the sensitivity, the quicker the wipers will react and the faster the wipe.

When activating automatic wiping or when increasing sensitivity, one sweep of the blades is performed.

Note :

- the rain sensor is only intended as a driving aid. In the event of reduced visibility, the driver should manually activate the wipers. In foggy weather or during snowfalls, wiping is not automatically triggered and remains under the driver's control ;
- in the event of temperatures below zero, automatic wiping is not activated when the vehicle is started. It is automatically activated as soon as the vehicle exceeds a certain speed (approximately 5 mph (8 km/h)) ;
- do not activate automatic wiping in dry weather ;
- fully de-ice the windscreen before activating automatic wiping.
- when washing the vehicle under a roller type car wash, return the stalk **1** to the **B** position to deactivate automatic wiping.

Operating faults

In the event of a malfunction of the automatic wiping, the wiper is set to intermittent wiping. Contact an authorised dealer.

The operation of the rain sensor can be disturbed in the event of :

- damaged wiper blades ; a screen of water or traces left by a blade in the sensor's detection zone may increase the response time of the au-

tomatic wiper, or increase the wiping frequency ;

- a windscreen with any chip or crack level with the sensor, or a windscreen covered in dust, dirt, insects, ice, the use of washing wax and water-repellent chemicals ; the automatic wiping will be less sensitive, or even unresponsive.

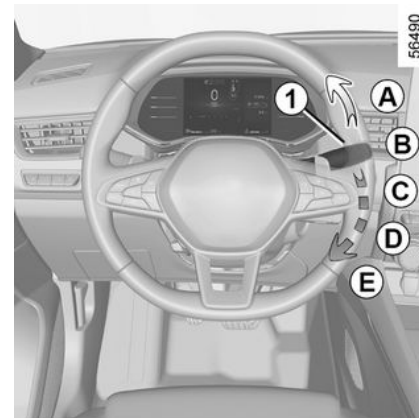

D slow continuous wiping

E fast continuous wiping

Special note

When driving the vehicle, the wiping speed slows down whenever the vehicle stops. For example, fast wiping speed will slow to normal wiping speed. As soon as the vehicle moves

2

WIPER

off, wiping will return to the speed originally selected.

If stalk **1** is operated, it overrides and cancels the automatic function.

Precautions

- In the event of ice, check whether the blades are stuck to the windscreen before operating the wiping mechanism. If you activate the wipers while the blades are stuck down with ice, you may risk damaging both the blade and the wiper motor.
- Do not activate the wipers on a dry screen. This will lead to premature wear or damage to the blades.

Specific front wiper position (service position)

This position enables the blades to be lifted to remove them from the windscreen.

This can be useful :

- to clean the blades ;
- to release the blades from the windscreen in winter ;
- replace the blades. → **322**

With the ignition on or engine started, lift the stalk **1** twice to position **A** (single sweep). The blades stop slightly away from the bonnet.

To return the blades to low position, with the ignition on, ensure that the wipers have folded down onto the windscreen, then move the stalk **1** to position **A** (single sweep).

Before switching on the ignition, place the wipers on the windscreen. Otherwise, there may a risk of damage to the bonnet or the wipers when they are switched on.

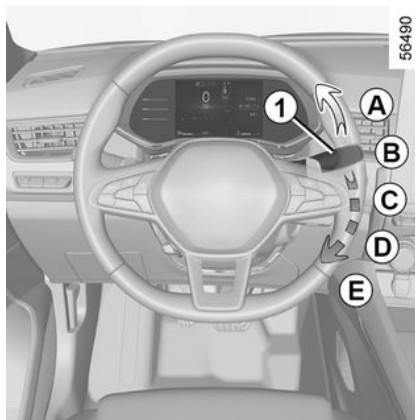

Before any action involving the windscreen (washing the vehicle, de-icing, cleaning the windscreen, etc.) return stalk **1** to position **B** (stop).

Risk of injury and/or damage.



In the event of obstacles on the windscreen (dirt, snow, ice etc.), clean the windscreen (including the central area located behind the interior rear view mirror) before starting the wipers (risk of motor overheating).

If an object is preventing a blade from moving, it may stop functioning. Remove the obstacle and reactivate the wiper using the wiper stalk.

WIPER

Windscreen washer

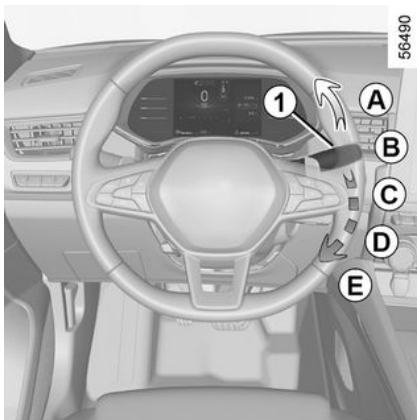

With the ignition on, pull stalk **1** then release.

A longer pull will trigger, in addition to the windscreen washer, two sweeps of the wipers followed, a few seconds later, by a third.

On vehicles fitted with a multimedia screen, you can choose to activate or disable the third sweep of the blades. → **105**

Note :

In temperatures below zero, the washer liquid risks freezing to the windscreen, thereby reducing visibility. Heat the windscreen using the demister control before cleaning.



When working in the engine compartment, ensure that the windscreen wiper stalk is in position **B** (stop).

Risk of injury.



Efficiency of a wiper blade

Check the condition of the wiper blades. How long they last depends on you :

- it must remain clean : clean the blade and the screen regularly with soapy water ;
- do not use it when the screen is dry ;
- free it from the screen when it has not been used for a long time.

In all cases, replace it as soon as it begins to lose efficiency : approximately once a year. → **322**

Precaution for using the wipers

- In freezing or snowy weather conditions, clear the screen before starting the wipers (risk of motor overheating) ;
- ensure that no objects are obstructing the travel of the blade.

FUEL TANK

2

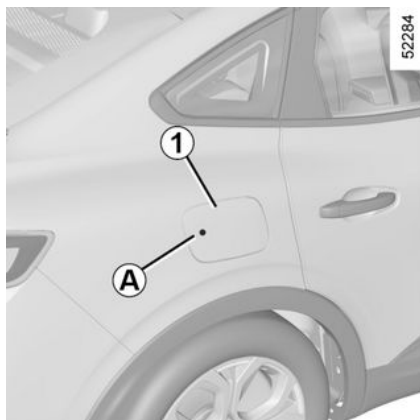

Useable tank capacity :

– About **11 gallons (50 litres)** ;

With the vehicle unlocked, to open cover **1**, press area **A** then release. The cover **1** opens.

Use the cap holder **2** on the flap **1** during filling to hold the cap **3** in place.

For details on filling the fuel tank, refer to the information on "Filling with fuel".

To close it, press on the fuel filler flap by hand, as far as it will go.

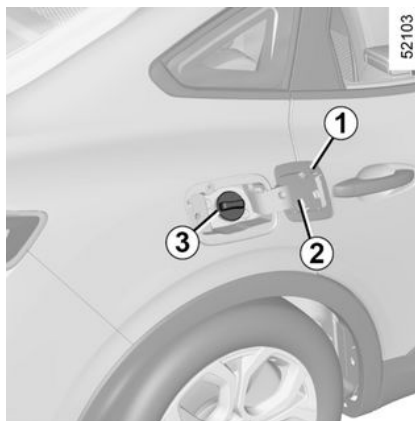

Filler cap : this is specific.

If you have to replace it, make sure it is identical

to the original cap. Contact an approved Dealer.

Never place the cap near a source of heat or flame.

Do not wash the filler area with a high-pressure washer.

with the specifications given on the label on the cover **1**. → **334**.



After filling, check that the cap and cover are closed.



Do not mix even small amounts of petrol (unleaded or E85) with diesel.

Do not use ethanol-based fuel if your vehicle is not compatible with this fuel.

Do **not** add additive to the fuel (additive, reagent, etc.), otherwise you could damage the engine.

If you wish to add an additive to the fuel, use a product approved by our Technical Department.

Consult an approved dealer.

Fuel grade

Use a high-grade fuel that complies with the legislation in force in each country and which must comply

FUEL TANK

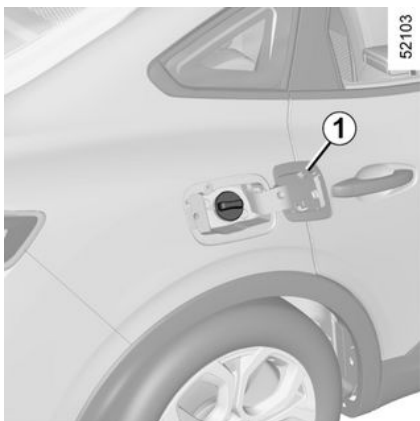

It is **essential** to use unleaded petrol. The octane rating (RON) must comply with the information given on the label on the cover **1**. → **334**.

Filling with fuel

With the ignition off, insert the nozzle and insert it **fully** before turning it on to fill the fuel tank (risk of splashing). Keep the nozzle in this position throughout the entire filling operation.

When the pump cuts out automatically at the end of the filling procedure, a maximum of two further filling attempts may be made, as there must be sufficient space in the fuel tank to allow for expansion.

After filling, refit the cap **3** and close the flap **1** to prevent any water or foreign bodies from entering the system.

Always make sure that the cap **3**, the flap **1** and its perimeter remain clean and free of dust, mud, dirt, etc.

Special case

When the vehicle has been stopped for around three months, **you must add fuel to prevent damage to the fuel pump**.

To do this, with the ignition off, fill up with fuel or top up with at least approximately 2.20 gallons (**10 litres**) then start the engine to operate the pump and renew the fuel in the circuit.

If it is not possible to add at least 2.20 gallons (10 litres) of fuel due to the fuel level in the tank, drive the vehicle until the tank has capacity.

Petrol versions

Using leaded petrol will damage the antipollution system and may lead to a loss of warranty.

To ensure that the fuel tank is not filled with leaded petrol, the fuel tank filler neck contains a restrictor fitted with a foolproof system which **only allows the nozzle for unleaded petrol to be used** (at the pump).

i Fuel types that conform to European standards with which the engines of vehicles sold in Europe are compatible : refer to the table → **334**.

i To fill up with fuel, the engine must be stopped (and not only on standby in case of vehicles equipped with the STOP and START function) : you must switch off the engine. → **128**
Fire hazard.

FUEL TANK

2



Persistent fuel odour

If you notice a persistent fuel odour you should :

- stop the vehicle as soon as traffic conditions allow and switch off the ignition ;
- switch on the hazard warning lights and ask your passengers to leave the vehicle and stay clear of the traffic ;
- contact an approved Dealer.



No modifications whatsoever are permitted on any part of the fuel supply system (elec-

tronic units, wiring, fuel circuit, injectors, protective covers, etc.) as this may be dangerous (unless undertaken by qualified Network personnel).

RUNNING IN

Petrol version

For the first **600 miles** (1,000 km), do not exceed 78 mph (130 km/h) in the highest gear, or 3,000 to 3,500 rpm.

You may only expect top performance from your vehicle after approximately **1,800 miles (3,000 km)**.

Service intervals : refer to the Maintenance Document for your vehicle.

Note : for a new vehicle in the running in phase : the coolant fluid level may be higher than the "MAXI" mark on the tank, then drop between the level "MINI" and "MAXI". This does not present a risk.

STARTING, STOPPING THE ENGINE

Vehicle with card

3



52344

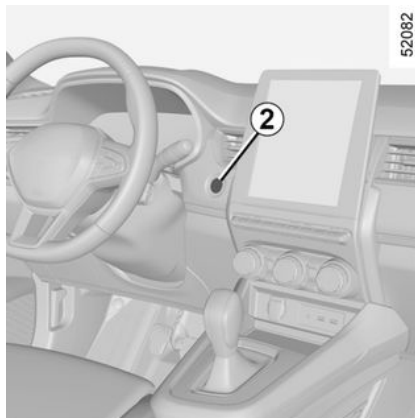

52082

The card must be inserted in detection zone **1**.

To start :

- on vehicles with an automatic gearbox, while in P position, press the brake pedal and **2** button ;
- For E-Tech full hybrid vehicle, the message READY comes on, on the instrument panel, along with a beep. The message disappears when the vehicle speed is above approximately 3.1 mph (5 km/h).

Special features

- If any of the starting conditions are not applied, the message "Press Brake + START" or "Select Gearbox Position "P"" will appear on the instrument panel ;
- in some cases, it will be necessary to move the steering wheel whilst pressing the start button **2** to help unlock the steering column ; the message "Turn Steering Wheel + START" will warn you of this ;

 On E-Tech full hybrid vehicle, in order to preserve the 12V battery, the engine unit will switch off automatically after approximately 12 minutes of the vehicle remaining stationary, as long as the driver's seat belt has not been fastened and the engine has not already been stopped manually using the **2** button. If necessary, you can restart the engine by pressing the **2** button once.

STARTING, STOPPING THE ENGINE



Driver's responsibility when parking or stopping the vehicle

Never leave an animal, child or adult who is not self-sufficient alone in your vehicle, even for a short time.

They may pose a risk to themselves or to others by starting the engine, activating equipment such as the electric windows or locking the doors, for example.

Also, in hot and/or sunny weather, please remember that the temperature inside the passenger compartment increases very quickly.

RISK OF DEATH OR SERIOUS INJURY.

"Hands-free" starting with the tailgate open

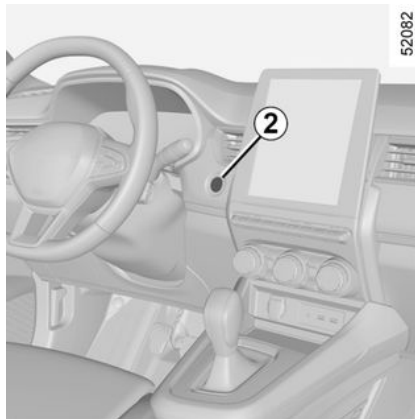

In this case, the card should not be located in the luggage compartment, to prevent the risk of loss.

Accessories function

(switching on the ignition)

Once you have gained access to your vehicle, you may use some of its functions (radio, navigation, wipers, etc.).

To use the other functions, with the card in the passenger compartment, press the **2** button without pressing the pedals.

Operating faults

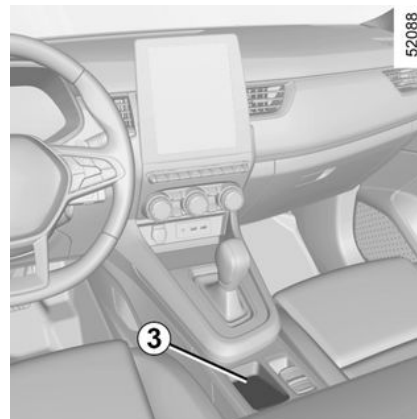

In certain cases, the hands-free card may not work:

- when the card battery is dead;
- secondary 12V battery is discharged, etc.;
- near to appliances operating on the same frequency as the card (monitor, mobile phone, video game, etc.);
- vehicle located in a high electromagnetic radiation zone.

STARTING, STOPPING THE ENGINE

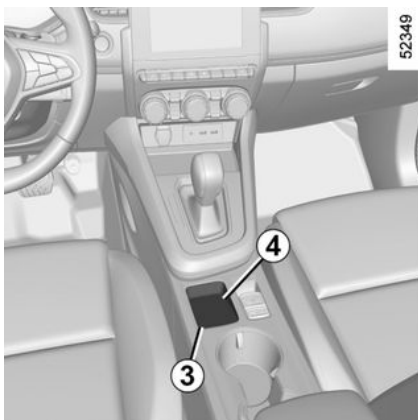

The message "Place card on zone + START" appears on the instrument panel.

Press the brake, then place the card **4** (button side) on the placement area **3**. Press the **2** button to start the vehicle. The message goes out.

Conditions for stopping the engine



The vehicle must be stationary, in P position on vehicles with an automatic gearbox. For E-Tech full hybrid vehicle, the READY message is displayed on the instrument panel.

With the card in the vehicle, press button **2** : the engine switched off. For E-Tech full hybrid vehicle, the READY message disappears from the instrument panel.

The steering column is locked when a door is opened or the vehicle is locked.

If the card is no longer in the passenger compartment or if the card battery is flat, when you try to switch the

engine off, the message "Card missing : press and hold" or the "Keycard absent : press/hold START" appears on the instrument panel : press the **2** button for at least two seconds. If the card is no longer in the passenger compartment, make sure you can retrieve it before pressing and holding the button. Without the card, you will not be able to start.

With the engine switched off, any accessories being used (radio, etc.) will continue to function for approximately 10 minutes.

When the driver's door is opened, the accessories stop working.

Exception for E-Tech full hybrid vehicle

With the vehicle stationary in electric operating mode, the message "ACTIVE ENGINE SWITCH OFF" appears on the instrument panel accompanied by a beep if :

- the driver's seatbelt is not fastened ;
- the bonnet is open ;
- the driver's door is open.

STARTING, STOPPING THE ENGINE



Never switch off the ignition before the vehicle has stopped completely. Once the engine has stopped, the brake servo, power-assisted steering etc., and the passive safety devices such as the airbags and pretensioners will no longer operate.



When you leave your vehicle, especially if you have your card with you, check that the engine is completely switched off.



Driver's responsibility when parking or stopping the vehicle

Never leave an animal, child or adult who is not self-sufficient alone in your vehicle, even for a short time.

They may pose a risk to themselves or to others by starting the engine, activating equipment such as the electric windows or locking the doors, for example.

Also, in hot and/or sunny weather, please remember that the temperature inside the passenger compartment increases very quickly.

RISK OF DEATH OR SERIOUS INJURY.

Stop and start function

This system enables a reduced fuel consumption and lower greenhouse gas emissions. The system is activated automatically when the vehicle is started. During driving, the system stops the engine (standby) when the vehicle comes to a stop or is moving at a slow speed (traffic

jam, traffic lights, etc), depending on the vehicle.

Conditions for engine standby

The vehicle has set off from where it was parked ;

- the gearbox is in position D, M or N ;
- and
- the brake pedal is depressed (sufficiently hard) ;

Depending on the vehicle, if the



warning light flashes and that the message "Press brake pedal" appears on the instrument panel, this indicates that the brake pedal is not sufficiently pressed ;

and

- the accelerator pedal is not depressed ;

and

- when the vehicle speed is zero during approximately one second or, depending on the vehicle, as soon as the vehicle speed is below approximately 3 mph (5 km/h).

The engine remains on standby if position P is selected, or if position N is selected with the handbrake engaged and the brake pedal released.

STARTING, STOPPING THE ENGINE

Warning light  on the instrument panel is lit when the engine is on standby.

The vehicle equipment remain operational while the engine is stopped.

When the engine switches to standby, the steering assistance may no longer be operational.

In this case it becomes operational again when the engine is no longer on standby or the speed exceeds approximately 1 mph (1 km/h) (downhill, slope etc.).



If the engine is put in standby, the electronic parking brake (depending on the vehicle) is not applied automatically.



Keep your vehicle stationary when the engine is on standby (shown by the warning

light  on the instrument panel).



The engine **MUST** be stopped (not put in standby) before leaving the vehicle → **128**.

Preventing the engine from standing by

In certain situations, such as negotiating a crossroads for instance, it is possible (with the system activated) to keep the engine running so as to be ready to move off quickly.

Keep the vehicle stationary without pressing too hard on the brake pedal.



To fill up with fuel, the engine must be stopped (and not put in standby): you **MUST** stop the engine → **128**.

Conditions for coming out of engine standby

- when the driver's door is opened;
- or
- when the driver's seat belt is unfastened;

- the brake pedal is released, position D or M engaged;
- or
- brake pedal is released, position N engaged and parking brake released;
- or
- parking brake is applied again, position P engaged, or position N engaged with parking brake applied;
- or
- position R is engaged;
- or
- the accelerator pedal is depressed;
- or
- in manual mode, the gear change paddles are activated.



"AUTOHOLD" function activated → **149**, the brake pedal may be released and the engine standby maintained.

To exit engine standby, with the brake pedal released, press the accelerator pedal.

STARTING, STOPPING THE ENGINE

Conditions preventing the standby of the engine

Certain conditions prevent the system from using the engine standby function, including when:

- the driver's door is not closed;
- the driver's seatbelt is not fastened;
- reverse gear is engaged;
- the bonnet is not locked;
- the outdoor temperature is too low or too high;
- the battery is not sufficiently charged;
- the difference between the vehicle interior temperature and the automatic climate control instruction is too high;
- parking distance control is in operation;
- the altitude is too high;
- the gradient is too steep for vehicles fitted with an automatic gearbox;
- the "Clear view" function is activated → 255;
- the engine temperature is too low;
- the emission control system is being regenerated;
- ...

Depending on the vehicle, warning light  is displayed on the instru-

ment panel. This notifies you that engine standby is not available.

The  warning light may appear along with a message on the instrument panel:

- "Optimising Battery Recharge" to prioritise battery charging;
- "Prioritising Thermal Comfort" to prioritise air conditioning;
- "Prioritising running engine" to prioritise engine operations.



Before carrying out any action in the engine compartment, you must switch off the ignition. or → 128

Special feature of the automatic engine re-start

Under certain conditions, the engine can restart on its own in order to guarantee your safety and comfort.

This can occur especially when:

- the outdoor temperature is too low or too high;
- the "Clear view" function is activated → 255;
- the battery is not sufficiently charged;

- the vehicle speed is above 3 mph (5 km/h) (downhill slope, etc.);
- repeated pressing on the brake pedal or braking system requirement;
- ...

Depending on the vehicle, the  warning light is displayed on the instrument panel to notify you of automatic engine restarting.



The engine **MUST** be stopped (not put in standby) before leaving the vehicle → 128.

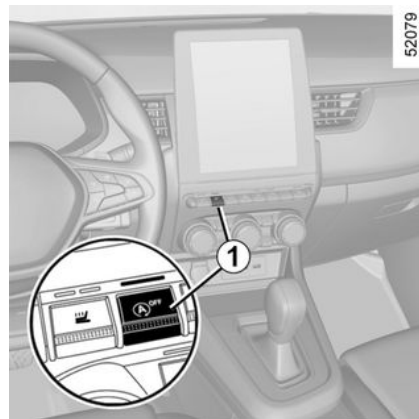

STARTING, STOPPING THE ENGINE

Depending on the vehicle, the  warning light may appear along with a message on the instrument panel :

- "Optimising Battery Recharge" to prioritise battery charging ;
- "Prioritising Thermal Comfort" to prioritise air conditioning ;
- "Prioritising running engine" to prioritise engine operations.

Deactivating, activating the function

Press **1** to deactivate the function. The message "Stop & Start deactivated" appears on the instrument panel and the ignition warning light **1** appears.

Pressing again will reactivate the system. The message "Stop & Start Activated" appears on the instrument panel and the **1** switch disappears.

The system is automatically reactivated each time the vehicle is started using the start button ➔ **128**.

Operating faults

When the "Check Stop & Start" message appears on the instrument panel and the **1** switch is on, this indicates that the system is deactivated.

Please consult an authorised dealer.



Special note : engine on standby, press switch **1** to automatically restart the engine.

GEAR CONTROL

Automatic gearbox, manual lever

Selector lever 1

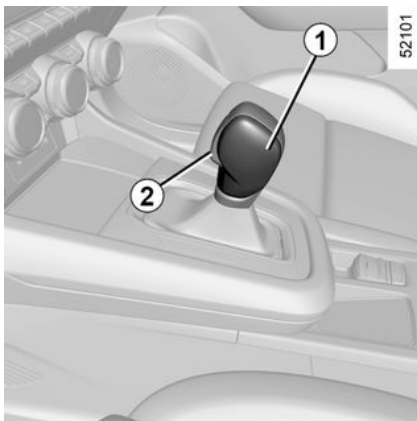

P : park

R : reverse

N : Neutral

D : automatic mode

B : (version E-Tech full hybrid) forward gear with increased regenerative braking

The **4** display on the instrument panel shows the position engaged by the selector lever **1** or displays the gear engaged in manual mode.

Note : Press the **2** button to:

- exit position P or
- switch from position D, N or B (E-Tech full hybrid version) to position R or P.
- switch from position D to B (E-Tech full hybrid version)

Operation

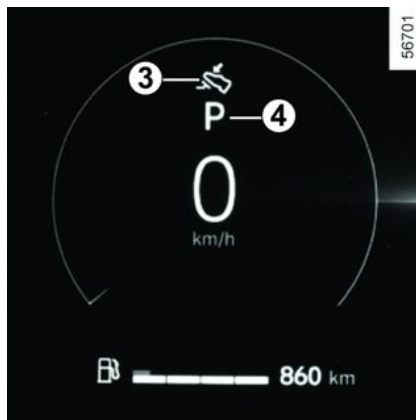

With gear lever **1** in position P, start the engine.

On E-Tech full hybrid vehicles, the message READY comes on, on the instrument panel.

To move out of position P, you must depress the brake pedal before pressing the unlocking button **2**.

With your foot on the brake pedal (warning light **3** on the display goes out), move the lever out of position P.

Only engage D or R when the vehicle is stopped, with your foot on the brake and the accelerator pedal released.

i On E-Tech full hybrid vehicles, the READY warning light displayed on the instrument panel indicates that the hybrid system is operating and ready for driving.

Driving in automatic mode

Put lever **1** into position D.

In most road conditions you will encounter, you will not need to touch your lever again : the gears will change automatically at the right time and at the most suitable engine speed because the automatic system takes into account the vehicle load and road contour and adjusts itself to the particular driving style you have chosen.

Economical driving

When driving, always leave the lever in position D, keeping the accelerator pedal lightly depressed to ensure

GEAR CONTROL

automatic gear changes at a lower engine speed.

Accelerating and overtaking

Depress the accelerator pedal firmly and fully.

This will enable you to change down to the optimum gear within the engine range.

Driving in mode B

On E-Tech full hybrid vehicles, this mode enables driving with greater regenerative engine braking. When releasing the accelerator pedal, the vehicle uses regenerative braking to slow down.

Thus the electric motor generates a higher electrical current which enables the traction battery to be recharged.

In B mode, the regenerative braking will be reduced if the accumulator is cold or completely charged.



The engine brake should under no circumstances be used as a substitute for the brake pedal.

Gear changing paddles 5 and 6



Depending on the vehicle, you can use paddles **5** and **6** to shift gear when the lever is in position D.

5 : Change to a lower gear.

6 : Change to a higher gear.

P, N and R are not accessible using the paddles.

Note : push the center of the paddles, not the upper end when using it.

Driving in manual mode

When driving in position D you can switch to manual driving mode using paddles **5** and **6** on the steering wheel. Depending on the vehicle,

two manual driving modes are available :

– the **“temporary” manual mode** can be used to force gear shifting by briefly pressing one of the two paddles. the driving mode D and the gear engaged appear on the instrument panel.

Note : the gearbox returns to automatic mode D automatically if the gear engaged is no longer optimal to vehicle performance or if no action was taken on a paddle for a certain amount of time.

– **permanent manual mode is activated** by pressing and holding either of the paddles. Driving mode M and the gear engaged will appear on the **7** display on the instrument panel.

GEAR CONTROL



Note : return to automatic mode by pressing and holding the right-hand paddle. Automatic mode D is displayed on the instrument panel.

In all situations :

- to move down through the gears, press the left-hand paddle ;
- to move up through the gears, press the right-hand paddle.

Special cases

In certain driving conditions (resulting in, for example, engine protection, operation of the Electronic Stability Control programme : ESC etc.) the automated system may change the gear automatically.

Likewise, to prevent incorrect manoeuvres, a gear change may be refused by the automatic system : in this case the gear display flashes for a few seconds as a warning.

 When facing uphill, to remain stopped, do not keep your foot on the accelerator.

Risk of overheating the automatic gearbox.

Special circumstances

- **If the road type or weather conditions** (steep uphill slopes, sudden downhill slopes, deep snow, sand or mud) make it difficult to stay in automatic mode, depending on the vehicle, it is advisable to switch to manual mode using the paddles. This will prevent the automatic gearbox from changing gears repeatedly when climbing, and permit engine braking on long descents.

- **In cold weather**, to prevent the engine from stalling, wait a few seconds before moving the selector lever from position P or N and engaging it in D or R.



For safety reasons, do not switch off the ignition before the vehicle has come to a complete standstill.

Parking the vehicle

When the vehicle is stopped, move the lever to position P while keeping your foot on the brake pedal : the gearbox is in neutral and the drive wheels are mechanically locked by the driveshaft.

Ensure that the electronic parking brake is engaged.



Position P must only be engaged when the vehicle comes to a complete stop.

GEAR CONTROL



An impact to the underside of the vehicle while manoeuvring (e.g. : striking a post, raised kerb or other street furniture) may result in damage to the vehicle (e.g. : deformation of an axle).

To avoid any risk of accident, have your vehicle checked by an approved Dealer.

Do not touch the circuit elements or any fluids or liquids.

Risk of serious injury or electric shock and risk to life.

Maintenance period

Refer to the maintenance document for your vehicle or consult an Approved Dealer to check whether the automatic gearbox requires scheduled maintenance.

If it does not need to be serviced, there is no need to top up the oil.

Operating faults

– **when driving**, if the message “WARNING : Check Gearbox” appears on the instrument panel, it indicates a failure.

Contact your approved Dealer as soon as possible ;

– **when driving**, if the message “WARNING : Gearbox Overheating” appears on the instrument panel, stop as soon as possible to let the gearbox cool down and wait for the message to disappear ;

– **troubleshooting on a vehicle with an automatic gearbox → 309.**

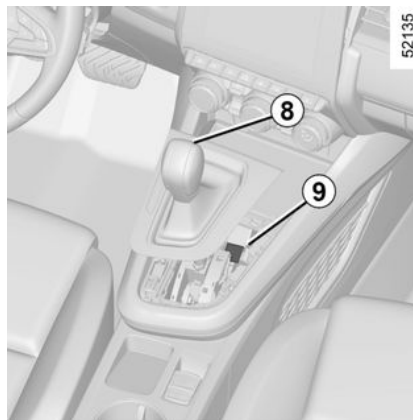

When setting off, if the lever is stuck in P when you press the brake pedal (e.g. battery fault), it is possible to manually release the lever to unblock the drive wheels. To do this, unclip the base of the gaiter and press the **9** button while simultaneously pressing the **8** button on the lever to

unlock the lever and shift to position N.

Contact an authorised dealer as soon as possible.

Automatic gearbox, electronic lever

Electronic selector lever (e-shifter) 1

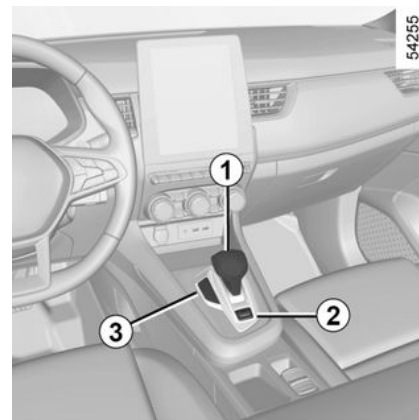

R : reverse gear

N : neutral

D : standard forward gear

P : park, button **2**

B : (version E-Tech full hybrid) forward gear with increased regenerative braking

GEAR CONTROL

The **3** indicator light displays the gear engaged.

On the instrument panel, the following symbols inform you :

47430

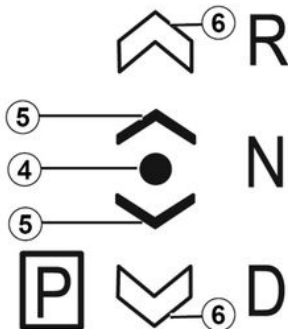

4 : position of the gear engaged ;

5 : position accessible from the current position by moving the selector lever **1** one notch forwards or backwards ;

6 : position accessible from the current position by moving the selector lever **1** two notches forwards or backwards.

The **5** or **6** symbols are displayed to indicate the gears that can be selected. If these symbols are absent this indicates that the gears cannot

be selected from the current position.

One-touch selector

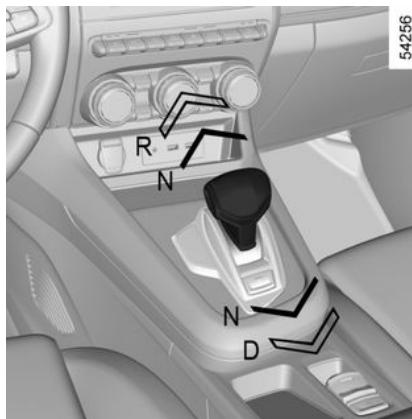

54256

Move the selector lever **1** one or two notches forwards or backwards to engage the desired position (R, N, D or B for E-Tech full hybrid) then release the lever and it will return to the stable position.

The engaged position is displayed on the instrument panel along with the **4** warning light in front of the position.

If certain conditions prevent shifting from one position to another, the requested position flashes on the instrument panel.

To engage P position

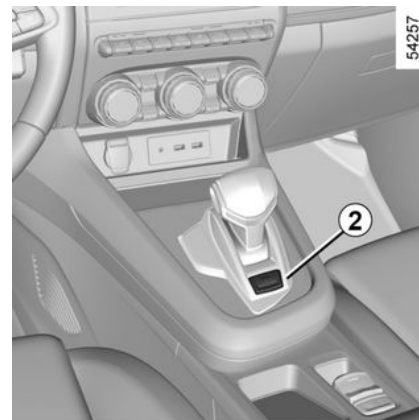

54257

With the vehicle at a standstill, engine running or ignition on (with the READY message on the instrument panel for E-Tech full hybrid version), press button **2** to engage position P. The warning light on button **2** lights up in orange once the Park position P is on the gearbox is engaged.

To disengage position P

With the vehicle stationary and the engine running (with the READY message on the instrument panel for E-Tech full hybrid version), press the brake pedal and move the selection lever **1** forwards or backwards according to the position desired.

3

GEAR CONTROL

The **2** button warning light switches off.

If the brake pedal is not fully depressed, the message "Press Brake

Pedal" and the warning light  are displayed on the instrument panel.

Note :

– if the driver opens their door to leave the vehicle and position P has not been engaged, a beep sounds and the message "Select Gearbox Position "P"" is displayed on the instrument panel ;

– the warning light  appears each time the brake pedal must be pressed to change the automatic gearbox lever position.

To engage neutral

With the vehicle stationary and the engine running (with the READY message on the instrument panel for E-Tech full hybrid version), to engage position N, move the selection lever **1** a notch forwards or backwards, depending on which gear is engaged.



On E-Tech full hybrid version, the READY warning light displayed on the instrument panel indicates that the hybrid system is operating and ready for driving. → 128



Check that warning light P on the instrument panel and the warning light integrated on the button **2** are activated before leaving the vehicle.
Risk of loss of immobilisation of the vehicle.

Driving in automatic mode D

With the vehicle stationary and the engine running (with the READY message on the instrument panel for E-Tech full hybrid version), shift the gear lever **1** two notches backwards to engage D position.

If one of the conditions is not applied, D flashes for around 5 seconds and the message "Push brake pedal" is displayed on the instrument panel for approximately 15 seconds.

When you select position D when the vehicle is stationary, the vehicle moves forward as soon as you release the brake pedal (without pressing on the accelerator pedal).

In most road conditions you will encounter, you will not need to touch your lever again : the gears will change automatically at the right time and at the most suitable engine speed because the automatic system takes into account the vehicle load and road contour and adjusts itself to the particular driving style you have chosen.

Note : with the engine running (with the READY message on the instrument panel for E-Tech full hybrid version) and the vehicle speed between approximately 0 and 5 mph (8 km/h) and position N or R engaged, it is necessary to depress the brake pedal to engage position D. This is useful during parking manoeuvres requiring a number of alternate forward and reverse movements.

Economical driving

When driving, always leave the lever in position D, keeping the accelerator pedal lightly depressed to ensure automatic gear changes at a lower engine speed.

Accelerating and overtaking

GEAR CONTROL

Depress the accelerator pedal briskly and fully (so that it goes beyond the point of resistance).

It is also possible to shift down at any time for overtaking purposes, by pressing the left-hand paddle.

Driving in mode B

For E-Tech full hybrid version, this mode enables driving with greater regenerative engine braking. When releasing the accelerator pedal, the vehicle uses regenerative braking to slow down.

Thus the electric motor generates a higher electrical current which enables the traction battery to be recharged.

In B mode, the regenerative braking will be reduced if the accumulator is cold or completely charged.

Move from D position to B or B to D

For E-Tech full hybrid version, to switch from one position to the other, tilt the lever to one notch or two notches backwards.

The engaged position is displayed on the instrument panel with the warning light **2** to confirm the position of the gear lever.

To select reverse gear

With the vehicle stationary and the engine running (with the READY message on the instrument panel for E-Tech full hybrid version), move the **1** selector lever two notches forwards to engage position R.

If the brake pedal is not depressed, a beep will sound, the display of position R flashes for around 5 seconds in the grid shown on the instrument panel, and the message "Press Brake Pedal" is displayed for approximately 15 seconds.

The reversing lights will illuminate as soon as reverse gear is engaged (if the ignition is on) as well as the reversing camera (depending on the vehicle).

Note : with the engine running (with the READY message on the instrument panel for E-Tech full hybrid version) and the vehicle moving between 0 and 5 mph (8 km/h), position N or D engaged, it is not necessary to depress the brake pedal to engage R. This is useful during parking manoeuvres requiring a number of alternate forward and reverse movements.

Gear shifting paddles 7 and 8

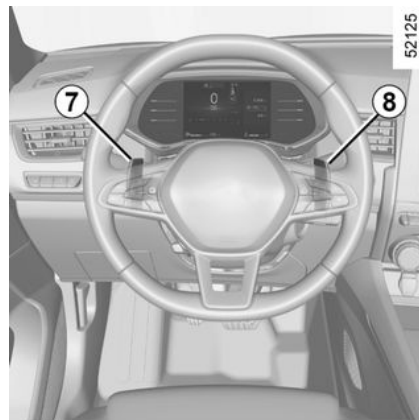

Depending on the vehicle, you can use paddles **7** and **8** to change gear when the lever is in position D.

7 : Change to a lower gear

8 : Change to a higher gear

P, N and R are not accessible using the paddles.

Driving in manual mode

When driving in position D you can switch to manual driving mode using paddles **7** and **8** on the steering wheel. Depending on the vehicle, two manual driving modes are available :

GEAR CONTROL

– the “temporary” manual mode

can be used to force gear shifting by briefly pressing one of the two paddles. the driving mode D and the gear engaged appear on the instrument panel. the letter D and the lower arrow appear brighter on the indicator light 3.

Note : the gearbox adjusts itself to automatic mode D if the gear engaged is no longer optimal to vehicle performance or if no action has been taken on a paddle for a certain amount of time.

– **permanent manual mode is activated** by pressing and holding either of the paddles. Driving mode M and the gear engaged will appear on the instrument panel.

Note : depending on the vehicle, you can return to automatic mode by pressing and holding the right-hand paddle or by moving the one-touch lever 1 one or two notches backwards.

In all situations :

- to move down through the gears, press the left-hand paddle ;
- to move up through the gears, press the right-hand paddle.

Special cases

In certain driving conditions (resulting in, for example, engine protection, operation of the Electronic Stability Control programme : ESC etc.) the automated system may change the gear automatically.

Likewise, to prevent incorrect manoeuvres, a gear change may be refused by the automatic system : in this case the gear display flashes for a few seconds as a warning.

Special circumstances

– **If the road type or weather conditions** (steep uphill slopes, sudden downhill slopes, deep snow, sand or mud) make it difficult to stay in automatic mode, depending on the vehicle, it is advisable to switch to manual mode using the paddles. This will prevent the automatic gearbox from changing gears repeatedly when climbing, and permit engine braking on long descents.

– **In cold weather**, to prevent the engine from stalling, wait a few seconds before moving the selector lever from position P or N and engaging it in D or R.

Parking the vehicle

On vehicles equipped with lever type 1, position P is engaged automatically, along with the electronic parking brake (on vehicles equipped), when :

- the ignition is switched off by pressing the start button ;
- the driver’s seatbelt is unbuckled and the vehicle is stopped ;
- the driver’s door is opened and the vehicle is stopped.

P is displayed on the instrument panel and the P button warning light is on.

As position P is **automatically engaged** when the engine is stopped, in some situations (e.g. when using some car washes) it may be necessary to engage position N :

- with the engine running (with the READY message on the instrument panel for E-Tech full hybrid version), press the P button, move the selector lever 1 one notch forwards or backwards then stop the engine ;
- with the engine off and the ignition on, move the selector lever 1 a notch forwards or backwards then switch off the engine.

The next time the engine is restarted, position P is engaged automati-

GEAR CONTROL

cally according to the cases described earlier.



P position must only be engaged when the vehicle is stationary.



When facing uphill, to remain stopped, do not keep your foot on the accelerator.

Risk of overheating the automatic gearbox.



For safety reasons, do not switch off the ignition before the vehicle has come to a complete standstill.

Maintenance period

Refer to the maintenance document for your vehicle or consult an Approved Dealer to check whether the automatic gearbox requires scheduled maintenance.

If it does not need to be serviced, there is no need to top up the oil.

Operating faults

– **when driving**, if the message “WARNING : Check Gearbox” appears on the instrument panel, it indicates a failure.

Contact your approved Dealer as soon as possible ;

– **when driving**, if the message “WARNING : Gearbox Overheating” appears on the instrument panel, stop as soon as possible to let the gearbox cool down and wait for the message to disappear ;

– **Troubleshooting on a vehicle with an automatic gearbox. → 309**

In the event of engine failure or an electrical fault (battery fault) affecting operation of the automatic gearbox, ensure that the vehicle is properly immobilised.



An impact to the underside of the vehicle while manoeuvring (e.g. : striking a post, raised kerb or other street furniture) may result in damage to the vehicle (e.g. : deformation of an axle).

To avoid any risk of accident, have your vehicle checked by an approved Dealer.

SPECIAL FEATURES OF PETROL VERSIONS

The following operating conditions should be avoided:

- driving for long periods when the low fuel level warning light is lit;
- using leaded petrol;
- using lubricant or fuel additives which are not approved.

Or operating faults such as:

- faulty ignition, running out of fuel or disconnected spark plugs resulting in the engine misfiring or cutting out when driving;
- loss of power.

may cause the catalytic converter to overheat, reducing its efficiency **which may irreparably damage it and cause heat damage to the vehicle.**

If you notice any of the above operating faults, have the necessary repairs carried out as soon as possible by an approved dealer.

These faults may be avoided by regularly taking your vehicle to an approved Dealer at the intervals specified in the Maintenance Document.

Starting problems

To avoid damaging the catalytic converter or the starter, and to prevent premature wearing of the battery, **do not keep trying to start the**

engine (using the start button, or by pushing or towing the vehicle) without having identified and corrected the starting fault.

If the fault cannot be identified, do not keep trying to start the engine, but contact an approved Dealer.



Do not park the vehicle or run the engine in locations where combustible substances or materials such as grass or leaves can come into contact with the hot exhaust system.

Particle filter

The particle filter is used in the treatment of exhaust gases from petrol engines.

Depending on the vehicle, the warn-

ing light  displayed on the instrument panel indicates that the filter is becoming clogged and requires cleaning. To clean it, when the

 warning light appears, and as traffic conditions and speed limits allow, drive at between about 31 mph

(50 km/h) and 68 mph (110 km/h) until the light goes out.

After between approximately 5 and 20 minutes, the warning light should go out.

Note: The indicator light may go out after 20 minutes when the driving conditions needed to clean the filter are not completely met.

If the vehicle is stopped before the warning light disappears you will have to restart the process from the beginning.

If the filter becomes saturated, the



warning light and, depend-

ing on the vehicle, the  warning light will appear on the instrument panel, accompanied by the message "Check injection". In this case, please consult an Authorised Dealer.

If the **STOP** warning light and, de-

pending on the vehicle, the  warning light appears, accompanied by the "WARNING: Engine Failure Risk" message, stop the vehicle, switch off the engine and contact an Approved Dealer.

SPECIAL FEATURES OF PETROL VERSIONS



Warning light **STOP** requires you to stop immediately, for your own safety, as soon as traffic conditions allow. Switch off the engine and do not restart it. Contact an approved Dealer.

PARKING BRAKE

Electronic parking brake

Assisted operation

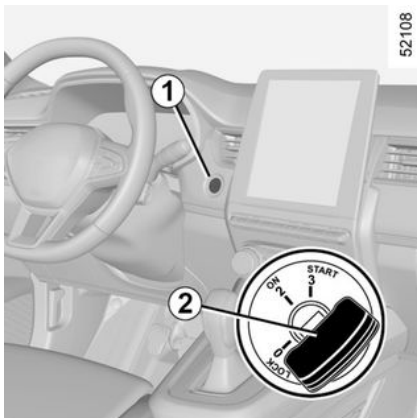

Applying the electronic parking brake

With the vehicle stationary, the electronic parking brake can be used to immobilise the vehicle:

– by pressing the engine start/stop button 1;

or

– when the driver's seat belt is unfastened;

or

– when the driver's door is opened;

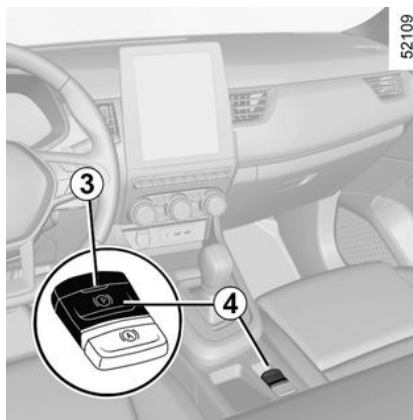

or

– for vehicles fitted with an automatic gearbox, when **position P is engaged**.



The electronic parking brake can be used to immobilise the vehicle.

Before leaving the vehicle, check that the electronic parking brake is fully applied. Warning light 3 on switch 4 and

warning light  on the instrument panel light up to show that the parking brake is applied but go out when the doors are locked. Depending on the vehicle, a sticker is located on the upper section of the windscreen to remind you of this.

In all other instances, for example **the engine has stalled or is in standby due to the Stop and Start** → 131, the assisted parking brake is not applied automatically. Manual mode must be used. For certain country-specific model versions, the assisted brake application function is not activated. Refer to the information on "Manual operation".

To confirm that the electronic parking brake is applied, the message "Parking Brake ON" is displayed, the

PARKING BRAKE

(P) warning light appears on the instrument panel and the **3** warning light appears on the **4** switch.

After the engine is switched off, indicator light **3** goes out several minutes after the assisted parking brake has been applied and indica-

tor light **(P)** goes out when the vehicle is locked.

Note : in some situations (electronic parking brake failure, manual release of the parking brake, etc.), a beep sounds and the message "WARNING: Apply Parking Brake" appears on the instrument panel to warn you that the electronic parking brake has been released.

- with the engine running : when the driver's door is opened ;
- with the engine switched off (e.g. when the engine stalls) : when a front door is opened.

In this case, pull and release switch **4** to apply the assisted parking brake.

Assisted release of the parking brake

The brake will be released as soon as the vehicle starts and accelerates.



Before leaving the vehicle, check that the electronic parking brake is fully applied.

Warning light **3** on switch **4** and

warning light **(P)** on the instrument panel light up to show that the parking brake is applied but go out when the doors are locked.

Manual operation

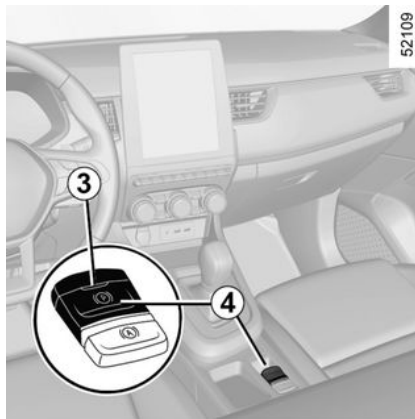

You can apply the electronic parking brake manually.

Manually applying the electronic parking brake

Pull switch **4**. Warning light **3** and

warning light **(P)** on the instrument panel light up.

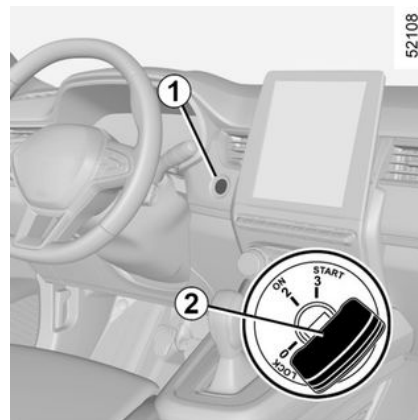

Manually releasing the electronic parking brake

Press switch **1** without pressing the pedals. Press the brake pedal then press switch **4** : indicator light **3** on

the switch and indicator light **(P)** displayed on the instrument panel go out.

52108

3

PARKING BRAKE

Brief stop



To apply the electronic parking brake manually (when stopping at a red light, or stopping when the engine is running, etc.): pull and release the switch **4**. The brake is released as soon as the vehicle is started up again.

Special cases

To park on a slope or while towing a trailer, for example, pull switch **4** for a few seconds to gain the maximum braking.

To park the vehicle without applying the electronic parking brake (if there is a risk of freezing, for example):

- engage any gear or the P position: the drive wheels will be mechanically locked by the driveshaft;
- switch off the engine by pressing the engine start/stop button
- release the driver's seat belt;
- open the driver's door;
- manually release the electronic parking brake (please see the information on "manually releasing the electronic parking brake");
- depending on the vehicle, the electronic parking brake is applied automatically. You will have to release it manually.



If no lights or sounds are apparent, this indicates a fault in the instrument panel. This indicates that it is essential to stop immediately (as soon as traffic conditions allow). Ensure that the vehicle is correctly immobilised and contact an approved Dealer.



If the message "WARNING : Electric System" or "Check battery" or "WARNING : Braking System" is displayed, you must immobilise the vehicle by selecting first gear (on a manual gearbox) or position P (on an automatic gearbox) or by pulling the switch **4** for approximately 10 seconds. If the conditions and the slope require it, chock the wheels of the vehicle.
Risk of loss of immobilisation of the vehicle.
Call an approved Dealer.

Versions with an automatic gearbox

For safety reasons, automatic release is deactivated when the driver's door is open or not shut properly and the engine is running (in order to prevent the vehicle from moving without the driver). The "Release Parking Brake Manually" message appears on the instrument panel when the driver depresses the accelerator.

PARKING BRAKE

Operating faults

– If there is a fault, the  warning light illuminates on the instrument panel accompanied by the "Check Parking Brake" message

and, in some cases, the  warning light.

Contact your approved Dealer straight away.

– If there is an assisted parking brake fault, the warning light

STOP comes on, along with the message "WARNING: Braking System", a beep and, in some cases, the

warning light .

This means that you must stop as soon as traffic conditions allow.



Never leave your vehicle without re-engaging P position and switching off the engine. This is because when the vehicle is stationary with the engine running and a gear engaged, the vehicle may begin to move if you accelerate.

There is a risk of accidents.

Autohold

Vehicle stopped (e.g. at a red light, an intersection, a traffic jam, etc.), the function ensures braking force even when the driver releases the brake pedal.

The braking force is released as soon as the driver accelerates sufficiently with a gear engaged.

Activation

Press the switch **3**.

The **3** warning light switch illuminates to confirm that the function is activated.

Deactivation

Press the brake pedal and **3** switch simultaneously.

The **3** switch warning light disappears to confirm that the function is deactivated.

If the braking force is maintained, the parking brake is applied automatically when :

- the driver exits the vehicle ;
- or
- the vehicle is immobilised for more than approximately three minutes.

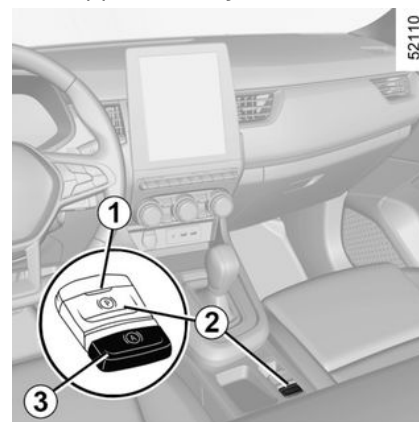

Conditions for maintaining the braking force

The following conditions must be met :

- the seat belt for the driver is fastened ;
- and

PARKING BRAKE

– the electronic parking brake is released;

and

– the vehicle is not stationary on a very steep slope.

The maintained braking force is con-

firmed by the  warning light on the instrument panel.

Conditions for interrupting the braking force

The following conditions must be met:

– the driver accelerates sufficiently with a gear engaged;

or

– the driver disables the function.

Warning light  goes out on the instrument panel.



Upon each start-up, the function continues the mode set at the time the engine was last switched off.



Before leaving the vehicle, check that the electronic parking brake is fully applied.

Warning light **1** on switch **2** and

warning light  on the instrument panel light up to show that the parking brake is applied but go out when the doors are locked.

DRIVING ADVICE, ECO DRIVING

Fuel consumption is accredited in accordance with a standard regulatory method. Identical for all manufacturers, this enables vehicles to be compared with one another. Consumption in real time depends on vehicle usage conditions, the equipment fitted and the user's driving style. To optimise fuel consumption, please refer to the following advice.

Depending on the vehicle, you will have various functions which enable you to lower your fuel consumption :

- the rev counter ;
- gear change indicator ;
- the driving style indicator ;
- the journey record and eco-driving advice via the multimedia screen ;
- acceleration indicator Eco ;
- ECO mode ;
- the Stop and Start function; ➔ 131
- Charge meter for E-Tech full hybrid vehicle.

If fitted on the vehicle, the navigation system provides additional information.

On the instrument panel A or B

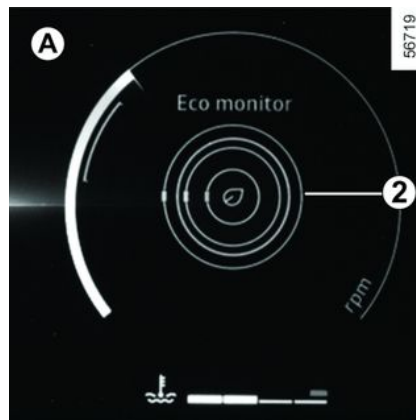

Depending on the vehicle, the information display can be organised and customised based on the instrument panel customisation style selected from the multimedia screen.

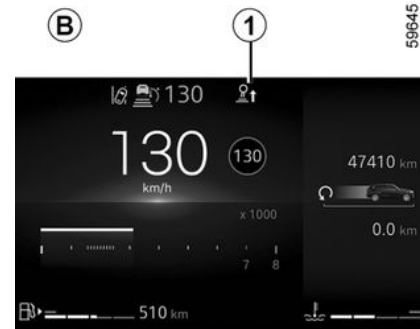

Gear change indicator 7

Depending on the vehicle, to obtain optimum consumption levels, a warning light on the instrument panel lets you know the best time to move up or down a gear :



shift up a gear ;



downshift a gear.

If you regularly follow this indicator, you will reduce your vehicle's fuel consumption.

DRIVING ADVICE, ECO DRIVING

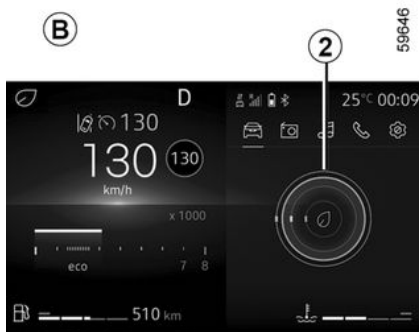

Driving style indicator 2

Informs you about the driving style adopted in real time. This is shown by indicator light 2.

The more petals displayed on 2, the more your driving is flexible and economical.

If you regularly monitor this indicator, you will reduce your vehicle's fuel consumption.

Please refer to the multimedia instructions for further information.



Acceleration indicator Eco 3

This informs you in real time whether you are accelerating moderately or strongly.

This is shown by the 3 warning light:

- green : acceleration is moderate and correct ;
- white : acceleration is too high ;
- grey : acceleration is high.

Note : it is not possible to simultaneously display the driving style indicator 2 and the Eco acceleration indicator 3.

ECO mode

ECO mode is a function which optimises fuel consumption. It acts upon

certain power consuming systems in the vehicle (heating, air conditioning, power-assisted steering, etc.) and on certain driving actions (acceleration, gear changing, cruise control, deceleration, etc.).

Limiting acceleration enables low fuel consumption in urban and surrounding areas. Reduced usage of the air conditioning reduces fuel consumption without affecting heating comfort.

Free wheel in ECO mode (or My Sense mode depending on the vehicle)

Depending on the vehicle, for vehicles fitted with an automatic gear-box, in the deceleration phases (with the foot fully off the accelerator pedal), switching to freewheeling (automatic neutral) decreases engine braking and allows you to farther without accelerating in order to save fuel.

To activate/deactivate "Free wheel" mode, refer to the multimedia instructions.

DRIVING ADVICE, ECO DRIVING

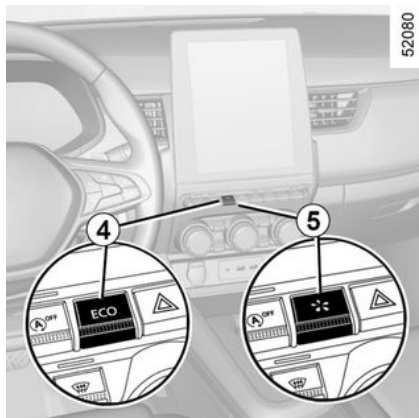

Activating the function

Depending on the vehicle, the function can be activated either :

- by pressing the **4** switch ; ➔ **249**
- by pressing switch **5** ;
- from the multimedia screen (refer to the multimedia equipment instructions).

The warning light **Eco** comes on on the instrument panel to confirm activation.

While driving, it is possible to leave the ECO mode temporarily in order to improve engine performance.

To do this, press the accelerator pedal firmly and fully.

ECO mode is reactivated when you take pressure off the accelerator pedal.

Disabling the function

Depending on the vehicle, the function can be deactivated either :

- by pressing the **4** switch ; ➔ **249**
- by pressing switch **5**.

The warning light **Eco** goes out on the instrument panel to confirm deactivation.

On the multimedia screen

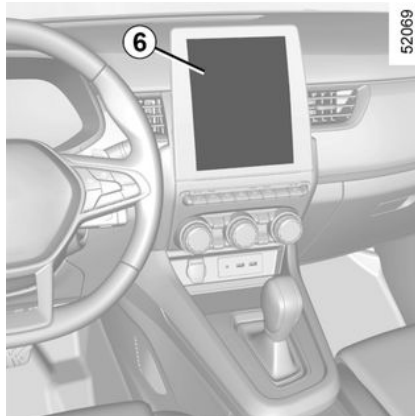

Journey record

Once the engine is switched off, you will see "Journey record" displayed

on the multimedia screen **6**, enabling you to view information on your last journey.

This indicates :

- the general score ;
- score evolution ;
- distance without fuel consumption.

Please refer to the multimedia instructions for further information.

An overall rating from 0 to 100 is displayed to let you assess your eco driving performance. The higher the rating, the lower the fuel consumption.

Eco advice is given to help improve your performance.

With your favourite journeys saved, you can compare your performance between trips and the performance of other vehicle users.

DRIVING ADVICE, ECO DRIVING

Charge meter



(on the instrument panel)

The charge meter gives the driver a real-time view of the vehicle's energy consumption.

Blue "Energy recovery" A usage zone

During driving, if you lift your foot off the accelerator pedal or press the brake pedal, the electric motor generates electrical current during deceleration and this energy is used to slow down the vehicle and recharge the traction battery.

"Energy consumption" B use area

The colour of the charge meter varies:

- **in green** : all-electric mode, the traction battery provides the energy required for the electric motor to power movement of the vehicle ;
- **in white** : hybrid traction mode, the traction battery and/or the combustion engine provide the energy required to power movement of the vehicle.

Maintaining the traction battery charge level: "E-save"

Available from your multimedia screen in two ways :

- activation/deactivation from the "Vehicle Settings" menu ;
- positionable widget on the home page.

This mode enables you to maintain a sufficient charge level in the traction battery in anticipation of a mountain road or a long motorway slope.

Driving advice and ECO driving

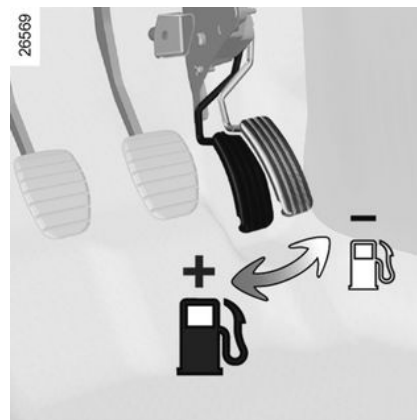

Behaviour

- Drive carefully for the first few miles until the engine reaches its normal operating temperature, rather than let it warm up while the vehicle is stationary.
- High speeds significantly affect the vehicle's fuel consumption.

Examples (at a steady speed) :

- reducing the speed from 80 mph (130 km/h) to 68 mph (110 km/h) approximately saves up to 20 % of fuel approximately ;
- reducing the speed from 56 mph (90 km/h) to 50 mph (80 km/h) ap-

DRIVING ADVICE, ECO DRIVING

proximately saves up to 10 % of fuel approximately.

- Dynamic driving with a lot of frequent acceleration and braking is expensive on fuel in comparison to the time saved.
- Do not over rev the engine in the intermediate gears. You should always use the highest gear possible.
- Avoid sudden acceleration.
- Brake as little as possible. If you anticipate an obstacle or bend in advance, you may then simply release the accelerator pedal.
- Do not try to maintain the same speed up a hill, accelerate no more than you would on the level. Keep your foot in the same position on the accelerator pedal.
- Double declutching and accelerating before switching off are unnecessary in modern vehicles.
- Bad weather, flooded roads :



Do not drive through floods if the water is above the lower edge of the wheel rims.

Heating level

It is normal to notice an increase in the vehicle's fuel consumption when using the heating (particularly when the outside temperature drops below zero) or air conditioning.



Obstructions to the driver

On the driver's side, only use mats suitable for the vehicle, attached with the pre-fitted components, and check the fitting regularly. Do not lay one mat on top of another.

There is a risk of wedging the pedals

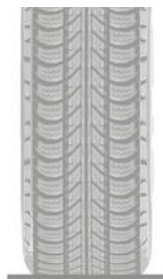

26528



Tyres

- An underinflated tyre increases fuel consumption.

- To optimise fuel consumption, set the highest speed tyre pressure or the recommended pressure indicated on the edge of the driver's door.

➔ 299

- The use of non-recommended tyres can increase fuel consumption.

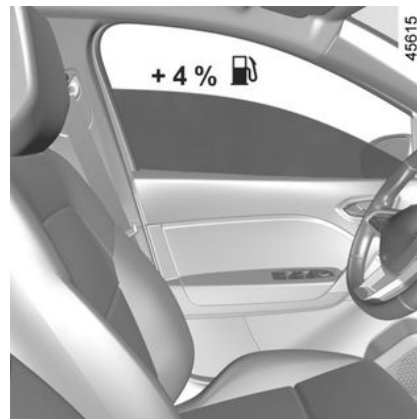

Advice on use

- Favour the ECO mode.
- Electricity is fuel; switch off all the electrical components which are not really needed. **However** (safety first), keep your lights on when the visibility is bad ("see and be seen").
- Use the air vents. Driving with the windows open at 60 mph (100 km/h)

DRIVING ADVICE, ECO DRIVING

will increase fuel consumption by 4 %.

- Never fill the fuel tank right to the brim to avoid overflow.
- **On vehicles equipped with non-automatic air conditioning**, switch off the air conditioning when it is not required.

Advice for reducing consumption and therefore helping to preserve the environment :

If the vehicle has been parked in the sun, open the doors for a few moments to let the hot air escape before starting the engine.

- Do not leave an empty roof rack fitted to the vehicle.
- It is better to fit a trailer for bulky objects.
- When towing a caravan, fit a wind deflector and adjust it carefully.
- Avoid using the car for door-to-door calls (short journeys with long waits in between) because the engine never reaches its normal operating temperature.

ENVIRONMENT

Your vehicle has been designed with respect for the **environment** in mind for its entire service life : during production, use and at the end of its life.

Manufacture

Your vehicle has been manufactured at a factory which complies with a policy to reduce the environmental impact on the surrounding areas (reduction of water and energy consumption, visual and noise pollution, atmospheric emissions and waste water ; sorting and reusing waste).

Emissions

Your vehicle has been designed to emit fewer greenhouse gases (CO₂) while in use, and therefore to consume less fuel (eg. 225 g/mile (140 g/km), equivalent to 1.17 gal/62 miles (5.3 l/100 km) for a diesel vehicle).

Our vehicles are also equipped with a particle filter system including a catalytic converter, an oxygen sensor and an active carbon filter (the latter prevents vapour from the fuel tank being released into the open air).

Please make your own contribution towards protecting the environment too.

– Parts and vehicles at the end of their life must not be thrown away. They must be handed to a legal entity that complies with environmental standards.

26913



- Worn parts and components that are replaced during routine vehicle maintenance, such as tyres or oil (tanks emptied or filled) must be disposed of at dedicated collection points.
- Worn electrical and electronic components that are replaced (such as batteries) must not be thrown away as rubbish. Take them to an

approved dealer or consult your local authority for information on appropriate recycling facilities.

– To optimise the recycling of your vehicle at the end of its life, you can contact an approved dealer or visit the manufacturer's website to be directed to collection points that guarantee respect for the environment according to local laws.

Recycling

Your vehicle is at least 85 % recyclable and at least 95 % recoverable.

To achieve these objectives, many of the vehicle components have been designed to enable them to be recycled. The materials and structures have been carefully designed to allow these components to be easily removed and reprocessed by specialist companies.

In order to preserve raw material resources, this vehicle incorporates numerous parts made from recycled plastics or renewable materials (vegetable or animal-derived materials such as cotton or wool).

MAINTENANCE AND ANTIPOLLUTION ADVICE

Your vehicle complies with criteria for recycling and recovering vehicles at the end of their service life, which entered into force in 2015.

Some parts of your vehicle have therefore been designed to facilitate future recycling.

These parts are easy to remove so that they can be recovered and re-processed by recycling companies.

By virtue of its design, moderate fuel consumption and initial settings, your vehicle also conforms to current antipollution regulations. The manufacturer is actively striving to reduce pollutant exhaust gas emissions and to save energy. But the fuel consumption of your vehicle and the level of pollutant exhaust gas emissions are also your responsibility. Ensure that it is maintained and used correctly.

Maintenance

It is important to remember that failure to respect antipollution regulations could lead to legal action being taken against the vehicle owner.

In addition, replacing engine, fuel supply system and exhaust components with parts other than those originally recommended by the manufacturer may alter your vehicle

so that it no longer complies with anti-pollution regulations.

Have your vehicle adjusted and checked by an authorised dealer, in accordance with the instructions given in your maintenance schedule : they will have all the equipment necessary for ensuring that your vehicle is maintained to its original standard.

Engine adjustments

– **Spark plugs** : for optimum conditions of use, output and performance the specifications laid down by our Design Department must be strictly applied.

If the spark plugs have to be changed, use the make, type and gap specified for your vehicle's engine. Contact an authorised dealer for this.

– **Ignition and idle speed** : no adjustment is needed.

– **Air filter** : a choked element will reduce efficiency. It must be replaced.

Exhaust gas monitoring system

The exhaust gas monitoring system will detect any operating faults in the vehicle's antipollution system.

If this system malfunctions, toxic substances may be released into the atmosphere or damage may occur.



This warning light on the instrument panel will indicate if there are any faults in the system :

This lights up when the ignition is switched on and goes out when the engine is started.

- If it lights up continuously, consult an approved Dealer as soon as possible ;
- if it flashes, reduce the engine speed until the light stops flashing. Contact an authorised dealer as soon as possible.

TYRE PRESSURE LOSS WARNING

43592

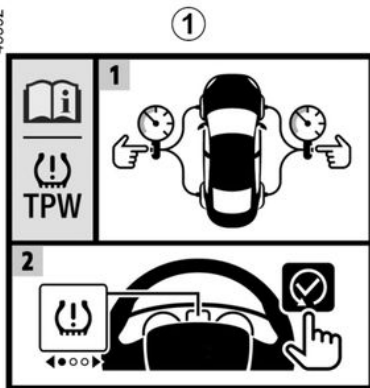

When fitted to the vehicle, this system notifies the driver if one or more tyres lose pressure.



45777

The system is fitted if there is a **1** label in the vehicle.

To verify its presence, open the driver's door.



56720

Operating principle

This system detects a loss of pressure in one of the tyres by measuring the wheel speed while driving.

Warning light  **2** comes on to alert the driver in the event of insufficient pressure (deflated wheel, punctured tyre, etc.).

Operating conditions

The system has to be reset with an inflation pressure equal to that written on the tyre inflation pressure la-

bel. Otherwise it risks not giving a reliable warning in the event of a significant loss of pressure → 299.

Resetting should always be carried out after checking the tyre pressure of all four tyres when cold.

In the following situations, the system risk coming into action late or not functioning correctly :

- system not reset after reinflation or any operation on the wheels ;
- system badly reset : different inflation pressures from the recommended pressures ;
- significant change in load or distribution of load on one side of the vehicle ;
- sporty driving with strong acceleration ;
- driving on snowy or slippery surface ;
- driving with snow chains ;
- fitting a single new tyre ;
- use of tyres not approved by the network ;
- ...

3

TYRE PRESSURE LOSS WARNING



This function is an additional driving aid.

The function does not take the place of the driver. It cannot, therefore, under any circumstances replace the vigilance or the responsibility of the driver.

Check the tyre pressures, including the emergency spare wheel, once a month.

Resetting the standard level for the tyre pressures

It must be carried out **with the vehicle stopped** :

- after each reinflation or readjustment of the pressure of one of the tyres ;
- when the standard tyre pressure needs to be changed to adapt to usage conditions (empty, carrying a load, motorway driving, etc.) ;
- after changing a wheel ;
- after using the tyre inflation kit ;
- after swapping a wheel (however, this practice is not recommended).

It should always be done after checking the tyre pressure of all four tyres when cold.

Tyre pressures must correspond to the current usage of the vehicle (empty, carrying a load, motorway driving, etc.).

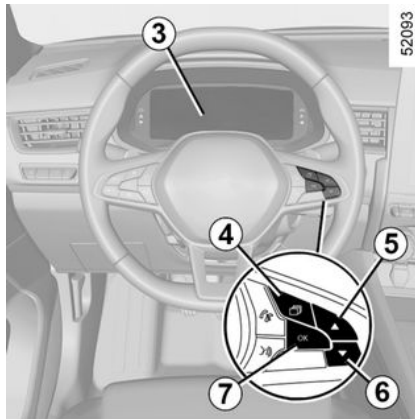

Resetting procedure

Ignition on, **vehicle stopped** :

- briefly press the **4** switch as many times as required to reach the "Vehicle" tab (or, depending on the vehicle, the Information page) ;
- briefly press the **5** or **6** switch to access the tyre pressures reset page ;
- press and hold the **7** OK switch to launch the reset.

The display of the message "If pressure OK [hold on]" for around five seconds indicates that the reset re-

quest for the tyre pressure reference value has been taken into account.

Reinitialisation is carried out after a few minutes' driving. The "Operation completed" message indicates that the tyre pressure reference value has been reset.

Display

The display **3** on the instrument panel informs you of any tyre pressure faults (flat tyre, punctured tyre, etc.).

"Check tyre press and init."

Warning light  comes on, along with the message "Check tyre press and init.". They indicate that at least one tyre is flat or punctured.

In the event of a flat tyre, inflate the relevant tyre.

In the event of a puncture, change the tyre or consult an authorised dealer.

Check and readjust the pressure of the four tyres when cold, and launch the reset of the tyre pressure reference value.

Warning light  goes out after launching the reinitialisation of the tyre pressure reference value.

TYRE PRESSURE LOSS WARNING



The sudden loss of pressure in a tyre (burst tyre, etc.) cannot be detected by the system.

“TPW not available”



The warning light  flashes for several seconds, then stays on, along with the message “TPW not available”.

They indicate that the vehicle is equipped with an emergency spare wheel which is smaller than the other four and that it is fitted to the vehicle.

“Check TPW”



The warning light  flashes for several seconds, then stays on, along with the message “Check TPW”.

This message is accompanied by

the warning light .

They indicate a system fault. Please consult an authorised dealer.

Readjustment of tyre pressures

The tyre pressures must be adjusted when cold (please refer to the label

located on the edge of the driver’s door).

If tyre pressures cannot be checked when the tyres are **cold, the recommended pressures should be increased by 0.2 to 0.3 bar (3 PSI)**.

Never deflate a hot tyre.

After each reinflation or readjustment of the tyre pressure, launch the reinitialisation of the tyre pressure reference value.

Replacing wheels/tyres

Only use equipment approved by the network, otherwise the system risks late activation or incorrect operation → **297**.

After each change of wheel/tyre, readjust the tyre pressure and launch the reset of the tyre pressure reference value.

Emergency spare wheel

If fitted on the vehicle, readjust the tyre pressure and launch the reinitialisation of the tyre pressure reference value.

Tyre repair product and inflation kit

Only use equipment approved by the network, otherwise the system risks late activation or incorrect operation → **300**.

After using the tyre inflation kit, readjust the tyre pressure and

launch the reinitialisation of the tyre pressure reference value.

DRIVING CORRECTION DEVICES AND AIDS

Depending on the vehicle, this is composed of:

- **anti-lock braking system (ABS)**;
- **electronic stability program (ESC) with understeer control and traction control**;
- **emergency brake assist**;
- **hill start assistance**.



These functions are an additional aid in the event of critical driving conditions, enabling

the vehicle behaviour to be adapted to suit the driving conditions.

These functions do not take the place of the driver. **They do not increase the vehicle's limits and should not encourage you to drive more quickly.** Under no circumstances should they replace the vigilance or responsibility of the driver when manoeuvring the vehicle (the driver must always be ready for sudden incidents which may occur when driving).

Anti-lock braking system (ABS)

Under heavy braking, the ABS prevents the wheels from locking, allowing the stopping distance to be managed and keeping control of the vehicle.

In these circumstances, the vehicle can be steered to avoid an obstacle whilst braking. In addition, this system can increase stopping distances, particularly on roads with low surface grip (wet ground etc.).





In an emergency, apply **firm and continuous pressure** to the brake pedal.





There is no need to pump it repeatedly. The ABS will modulate the force applied in the braking system.

You will feel a pulsation through the brake pedal each time the system is activated. The ABS does not in any way improve the vehicle's physical performance in terms of the road surface and road-holding. It is still **essential** to follow the rules of good driving practice (such as driving at a

safe distance from the vehicle in front etc.).

Operating faults :

-  and  lit up on the instrument panel accompanied by the messages "Check ABS", "WARNING: Check Braking System" and "Check ESC": the ABS, the ESC and the emergency brake assist are disabled. **Braking is always enabled**;

- , ,  and  lit on the instrument panel accompanied by the message "WARNING: Braking System": **this indicates a fault with the braking system.**

In both cases, please consult an Authorised Dealer.



Your braking system is partially operational. However, **it is dangerous to brake suddenly**

and it is essential to stop immediately, as soon as traffic conditions allow. Call an approved Dealer.

DRIVING CORRECTION DEVICES AND AIDS

Electronic stability program (ESC) with understeer control and traction control

Electronic stability program ESC

This system helps you to keep control of the vehicle in critical driving conditions (avoiding an obstacle, loss of grip on a bend, etc.).

Operating principle

A sensor in the steering wheel detects the direction selected by the driver.

Other sensors fitted throughout the vehicle measure the actual direction.

The system compares driver input to the actual trajectory of the vehicle and corrects the trajectory if necessary by controlling the braking of certain wheels and/or engine power. In the event that the system is trig-

gered, the  warning light flashes on the instrument panel.

Understeer control

This system optimises the action of the ESC in the case of pronounced understeering (loss of front axle road holding).

Traction control

This system helps to limit wheelspin of the drive wheels and to control

the vehicle when pulling away, accelerating or decelerating.

Operating principle

Using the wheel sensors, the system measures and compares the speed of the drive wheels at all times and slows down their over-rotation. If a wheel is starting to slip, the system brakes automatically until the drive supplied becomes compatible with the level of grip under the wheel again.

The system also adjusts the engine speed to the grip available under the wheels, independently of the pressure exerted on the accelerator pedal.

In some situations (driving on very wet ground : snow, mud, etc. or driving with snow chains fitted), the system may reduce the engine output to limit wheelspin.

Operating faults

When the system detects an operating fault the message "Check ESC"

and warning lights  and

 appear on the instrument panel. In this case, the ESC and traction control system are deactivated.

Consult an approved dealer.

Emergency brake assist

This system supplements the ABS and helps reduce vehicle stopping distances.

Operating principle

The system enables detection of an emergency braking situation. In this case, the braking system immediately develops maximum power and may trigger ABS regulation.

ABS braking is maintained as long as the brake pedal is applied.

Hazard warning lights switching on

Depending on the vehicle, these may light up in the event of sudden deceleration.

Braking anticipation

Depending on the vehicle, when you rapidly release the accelerator, the system anticipates the braking manoeuvre in order to reduce stopping distances.

Special cases

When using the cruise control :

- if you use the accelerator, when you release it, the system may be triggered ;
- if you do not use the accelerator, the system will not be triggered.

Operating faults

DRIVING CORRECTION DEVICES AND AIDS

When the system detects an operating fault the message "WARNING : Check Braking System" appears on the instrument panel along with the



warning light.

Consult an approved dealer.



These functions are an additional aid in the event of critical driving conditions, enabling

the vehicle behaviour to be adapted to suit the driving conditions.

These functions do not take the place of the driver. **They do not increase the vehicle's limits and should not encourage you to drive more quickly.** Under no circumstances should they replace the vigilance or responsibility of the driver when manoeuvring the vehicle (the driver must always be ready for sudden incidents which may occur when driving).

Hill start assistance

Depending on the gradient of the incline, this system assists the driver when starting on a hill. It prevents the vehicle from rolling backwards by automatically applying the brakes when the driver lifts his/her foot off the brake pedal to depress the accelerator pedal.

System operation

It only operates when the gear lever is in a position other than neutral (other than N or P on automatic gearboxes) and the vehicle is completely stationary (brake pedal depressed).

The system holds the vehicle for approximately **2 seconds**. The brakes are then gradually released (the vehicle will move according to the slope).



The hill start assistance system cannot completely prevent the vehicle from rolling

backwards in all situations (extremely steep gradients etc.). In all cases, the driver may depress the brake pedal to prevent the vehicle from rolling backwards.

The hill start assistance function should not be used for prolonged stops : use the brake pedal.

This function is not designed to immobilise the vehicle permanently.

If necessary, use the brake pedal to stop the vehicle.

The driver must remain particularly vigilant when driving on slippery or low-grip surfaces.

Risk of serious injury.

ADDITIONAL DRIVING AID FUNCTIONS

My Safety

The My Safety function can be used to deactivate or activate a set of driving assistance functions simultaneously.

Depending on the vehicle, you can configure the My Safety function from the multimedia screen by selecting the driving aid functions to be switched off as a group.

Operation



"All On" mode

Depending on the vehicle, the functions and configurations of driving assistance concerned are:

- lane departure prevention
- detection of road signs
- overspeed sound alert
- driver vigilance warning

When the "All On" mode is activated: the "My Safety All ON selected" message is displayed on the instrument panel to confirm this. The driving aids that are available in the mode are activated.

"Perso" mode

You can use this mode to deactivate or reactivate certain driving aids that are available in the "All On" mode previously configured using the "My Safety Perso" setting.

Once the ignition on, press the button **1** twice in quick succession.

On the first press, the "Press again for My Safety Perso" message is displayed on the instrument panel. On the second press, the warning light on the button **1** goes out. The "Perso" mode is activated. The "My Safety Perso selected" message is displayed on the instrument panel.

To switch back to "All On" mode, press the button **1** once. The indicator light on the button **1** lights up.



Depending on the length of time following the last time the engine was stopped, the alerts are reactivated:

- when the vehicle is unlocked;
- or
- when a door is opened;
- or
- when the engine is restarted.

Perso mode configuration

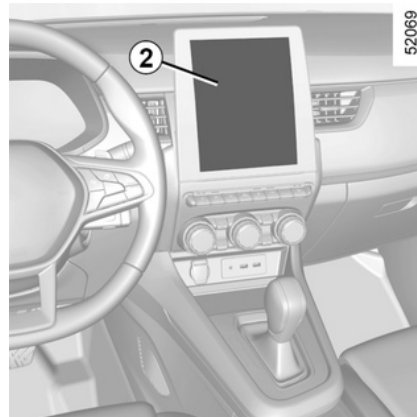

From the multimedia screen **2**

ADDITIONAL DRIVING AID FUNCTIONS

Please refer to the multimedia instructions for more information.

Lane departure prevention

56488

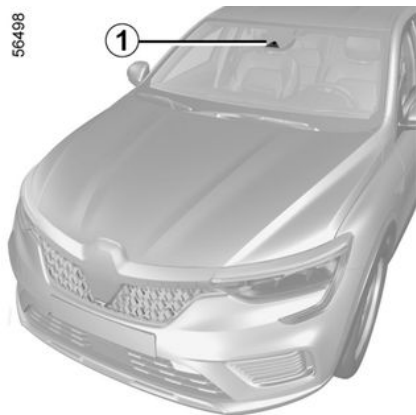

Using information from the **1** camera, the function triggers corrective action on the vehicle steering system when a continuous or dashed line is crossed or when approaching the roadside (divider, barrier, pavement, embankment, etc.) without activating the direction indicator lights.

Depending on the setting, in the event of crossing a dashed line without activating the direction indicator lights, the function:

- warns the driver without corrective action on the steering system;
- or
- performs corrective action on the steering system.



You can **retake control of the vehicle** at any time by operating the steering wheel.



This function is an additional driving aid and the driver is responsible for steering wheel operation. This system is not a substitute for the driver and the driver must drive with his hands on the steering wheel when driving.

Always be careful when driving, as the system may not be unexpectedly deactivated or operated, or may operate unnecessarily depending on the road conditions and attention circumstances.

Location of the camera **1**

Make sure the windscreen is not obscured (by dirt, mud, snow, condensation etc.).

Activation/deactivation

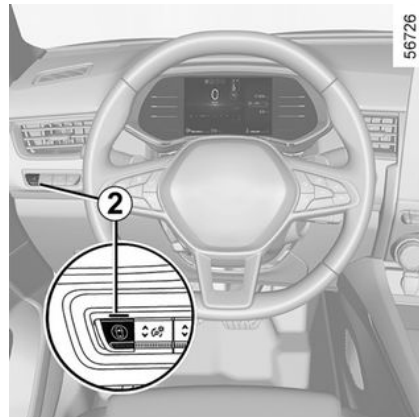

Activation, deactivation of warnings from button **2** "My Safety"

To deactivate the function, if it has been deactivated from the "custom" mode of the "My Safety Person" function, press the button **2** twice.

The warning light  is displayed in yellow on the instrument panel. To reactivate the function, press the

ADDITIONAL DRIVING AID FUNCTIONS

button **2** once. Warning light  comes on the instrument panel.

From the multimedia screen **3**

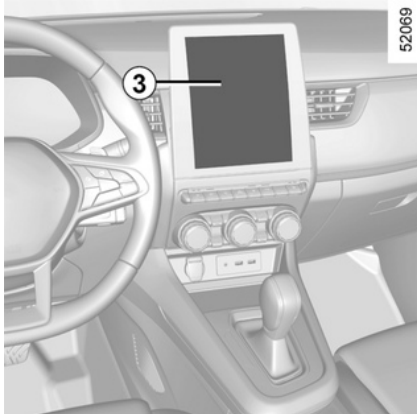



To activate or deactivate the function, refer to the multimedia instructions.

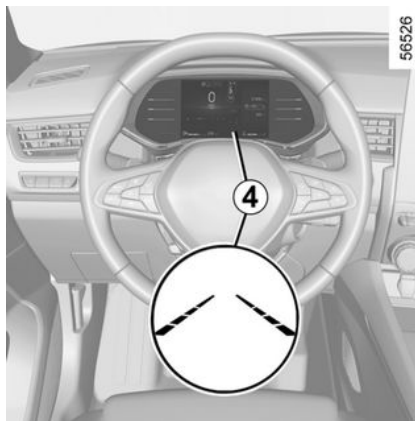

Select "ON" or "OFF".

Operation



When the function is activated, the  or  warning light and the left and right lines **4** are displayed in grey on the instrument panel.



The function is set to notify or to intervene if the vehicle speed is between approximately 40 mph (65 km/h) and 112 mph (180 km/h) or

99 mph (160 km/h) and if the  or  warning light and **4** correction indicators are coloured white.



The function is in operation if the vehicle;

- approaches a roadside without activating direction indicators;
- crosses a continuous line without activating the indicator lights;
- crosses a dashed line without activating the direction indicators, if the "dashed lines intervention" setting is selected.

In these cases:

- the function triggers an action on the vehicle's steering system to correct the vehicle trajectory;
- warning light  or  and the indicator **4** on the side of the breached line turns to yellow on the instrument panel.

If corrective action taken on the steering system is not sufficient, the

warning light  or  and the indicator **4** on the side of the breached side line are shown in red on the instrument panel, accompanied by a vibration on the steering wheel.



When the "Dashed lines intervention" setting is not selected, the function sounds the alarm if the vehicle crosses a dashed line without activating the indicator lights, and there is no roadside close enough to the line.

ADDITIONAL DRIVING AID FUNCTIONS

In this case, the function warns the driver:

– by a vibration in the steering wheel;

and

– warning light  or  and the indicator **4** on the side of the breached line turns to red on the instrument panel.

Note: on bends, the function allows for slightly cutting the bend.

Special cases

When using the system :

– If the system can no longer detect any action by the driver on the steering wheel, the  warning light appears in red on the instrument panel, accompanied by the message "Keep hands on steering wheel" and an audible warning.

ing wheel, the  warning light appears in red on the instrument panel, accompanied by the message "Keep hands on steering wheel" and an audible warning.



You can interrupt the trajectory correction at any time by moving the steering wheel.

– if the system is active for too long, an audible warning is emitted and

the indicator **3** on the side of the line concerned flashes until the driver takes control.



Please note that the system warning may appear late according to road conditions

when driver's hands are off the steering wheel.

Always have your hands on the steering wheel when driving.

The system may warn driver that driver is not holding the steering wheel when the driver operates steering wheel excessively or holds on the steering wheel softly.



Vehicle fitted with "Active driver assist"

If the "Lane centring" function is activated at the same time as the "Lane departure prevention" function, the display of the warning light will vary as follows:

– the "Lane centring" function is operating: the warning light  or



 in green replaces the warning



light  or  in white or grey on the instrument panel. Thus, you are informed as a priority of the status of the function "Channel centring";

– the "Lane centring" function is put on standby and the "Lane departure prevention" function is neither sounding an alarm nor operating:

the warning light  or  in grey replaces the warning light

 or  in white or grey on the instrument panel. Thus, you are informed as a priority of the status of the function "Channel centring";

– The "Lane centring" function is put on standby while the "Lane departure prevention" function is sounding an alarm or operating: the warn-

ing light  or  appears in red or yellow on the instrument panel. Thus, you are informed as a priority of the status of the function "Lane departure prevention".

In any case, you are informed at all times of the status of the function when it controls the steering system of your vehicle. The most useful information is always displayed.

Temporary unavailability / function disabled

ADDITIONAL DRIVING AID FUNCTIONS

The system is temporarily unavailable or disabled when:

- very fast lane departure;
- driving continuously on a line;
- approximately four seconds after changing lanes;
- tight bends;
- impaired visibility;
- one of the direction indicators is activated;
- activating the hazard warning lights;
- engaging reverse gear;
- strong acceleration;
- the lane width changes;
- operation of the Electronic Stability Control system
- operation of the anti-lock braking system;
- the active emergency braking system is triggered;
- intervention of another function that controls the steering system, such as the "Lane Centring" function.

When the function is unavailable,

the warning light  or  and left/right line correction indicators **3** turn to grey on the instrument panel.

If the front camera is obscured, the "Front camera without visibility" message is displayed on the instru-

ment panel. Clean the area where the sensors are located.

Automatic deactivation

- The function is automatically deactivated when;
- The vehicle dynamics control system is deactivated;
- The electronic stability system is malfunctioning;
- The anti-lock braking system is malfunctioning;
- a towbar is electrically connected to the trailer hitch socket;

- warning light  is displayed.

When the function is deactivated,

the warning light  is displayed in yellow on the instrument panel.

Adjustment

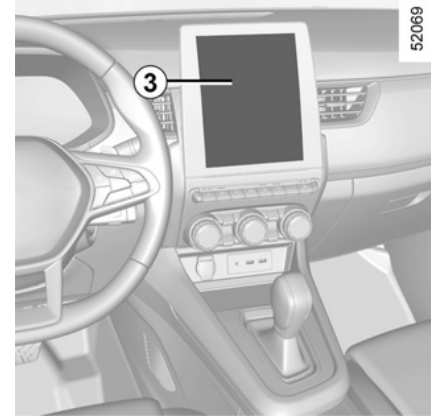

To access the multimedia screen function settings **3**, refer to the multimedia instructions:

- "Dashed lines intervention": use this setting to select the response of the function if the vehicle crosses a dashed line without activating the direction indicators:

- selected setting: the function may trigger an action on the vehicle's steering system to correct the vehicle trajectory;
- setting not selected: the function can warn the driver by means of a vibration at the steering wheel without correcting the vehicle trajectory.

ADDITIONAL DRIVING AID FUNCTIONS

– "Vibration": adjust the steering wheel vibration for the "Lane departure prevention" function;

– "Lane exit anticipation": adjust the line detection sensitivity level. To do this, select:

– "Late": line detected upon crossing;

– "Standard": line detected on approach;

– "Early" line detected nearby.

Please refer to the multimedia instructions for further information.

Operating faults

When the system detects an operating fault, the left-hand and right-hand line indicators and the warning

light  are displayed in yellow on the instrument panel.

In some cases, they are accompanied by the following message:

– "Driving assist unavailable";

or

– "Check Front camera";

or

– "Check Driving assist".

Consult an approved dealer.

Warnings



This function is an additional driving aid. This function is not under any circumstances intended to replace the due care and attention of the driver, who should at all times be in control of the vehicle.

System servicing/repairs

– In the event of an impact, the camera alignment may be changed, and its operation may consequently be affected. Deactivate the function and consult an authorised dealer.

– Any work in the area where the camera is located (repairs, replacements, windscreen modifications etc.) must be carried out by a qualified professional.

Only an authorised dealer is qualified to service the system.

In the event of system disturbance

Some conditions can disturb or damage the operation of the system, such as :

– windscreen obscured (by dirt, ice, snow, condensation etc.);

– a complex environment (tunnel etc.);

– poor weather conditions (snow, rain, hail, black ice etc.);

– poor visibility (night, fog etc.);

– the road markings are irregular or difficult to distinguish (e.g. partially erased, excessive spacing, distorted road surface);

– being dazzled (glaring sun, lights of vehicles travelling in the opposite direction etc.);

– the road is narrow, winding or undulating (tight bends etc.);

– closely following a vehicle travelling in the same lane.

In this case, the "Lane Keeping Assist" may react incorrectly or not at all.

Risk of unwanted, incorrect correction or no correction of trajectory.

Deactivating the function

You must disable the function if :

ADDITIONAL DRIVING AID FUNCTIONS

- the area of the camera has been damaged (on the wind-screen side or the interior rear-view mirror side);
- the road is slippery (snow, black ice, aquaplaning, gravel etc.);
- poor visibility (night, fog etc.);
- the windscreen is cracked or distorted (do not carry out windscreen repairs in this area; have it changed by an Authorised Dealer);
- the vehicle is towing a trailer or a caravan;
- the vehicle is entering an area with several surface markings (an area with road works etc.).

Blind spot warning

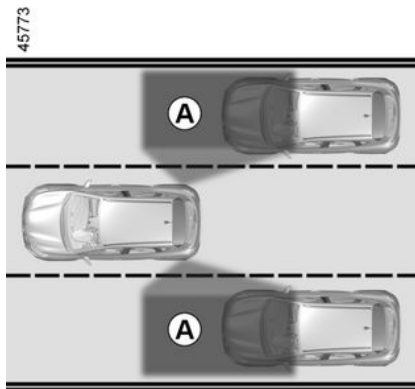

Using information from the sensors installed on each side of the rear bumper (area **C**), the function warns the driver:

- when another vehicle appears in the detection area **A**;
- and/or
- when there is a risk of collision with a vehicle that is in area **B**, driving faster than you.

The function warns you when the vehicle is travelling at a speed above approximately 9 mph (15 km/h).

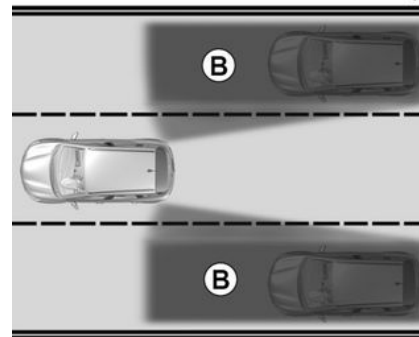

This function is an additional driving aid. This function is not under any circumstances intended to replace the due care and attention of the driver, who should at all times be in control of the vehicle.

ADDITIONAL DRIVING AID FUNCTIONS

Special feature

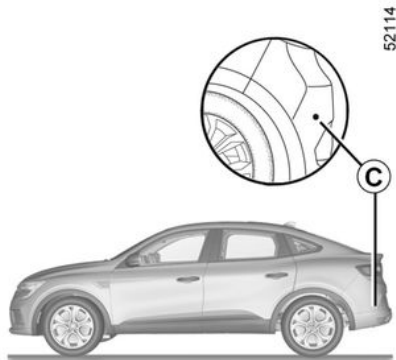

Ensure that the **C** area around the radars on each side of the rear bumper are not obstructed (by dirt, mud, snow etc.).

If a radar is obscured, the message "Side radars no visibility" will appear on the instrument panel. Clean the area where the sensors are located.

Indicator 6

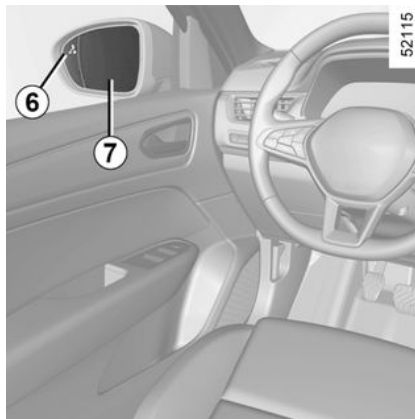

An indicator light **6** is located on each rear view mirror **7**.

Note : clean the rear view mirrors **7** regularly so that the indicators **6** can be seen.

Operation

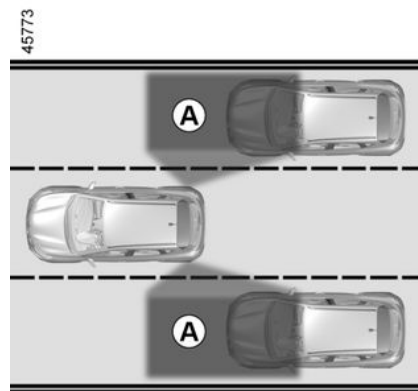

The function warns you when the speed of your vehicle is over 9 mph (15 km/h) :

- when another vehicle is in the blind spot area **A** and travelling in the same direction as your vehicle ;
- when a vehicle approaches quickly from the rear in an adjacent lane within the range of detection area **B**.

If you overtake another vehicle, the **6** indicator will only come on if that vehicle remains for a long enough period in your vehicle's blind spot **A**.

ADDITIONAL DRIVING AID FUNCTIONS

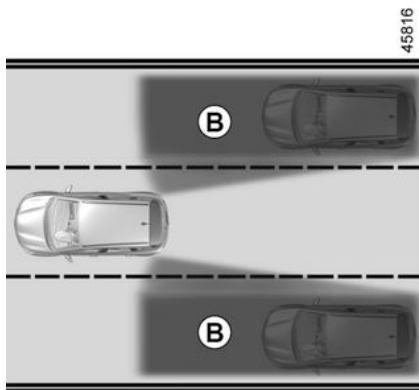

The function does not notify the driver if the other vehicles are not moving.

Display D

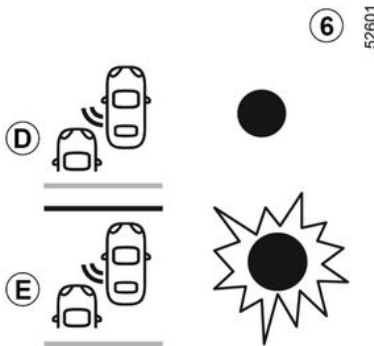

First warning : **direction indicator not activated**, the **6** warning light indicates that a vehicle is detected in the blind spot area and/or that a vehicle is rapidly approaching from the rear in an adjacent lane.



When the engine is started, the system adopts the last status saved before the ignition was switched off.

Display E

Direction indicator activated, the **6** warning light flashes when the func-

tion detects a vehicle in the blind spot warning area and/or a vehicle is rapidly approaching from the rear on the side towards which you will turn the wheel. If you cancel the direction indicator, the function will return to the initial warning (display **D**).

Conditions for non-function

- When driving on a road with tight bends;
- in reverse.

If the vehicle is equipped with a tow-bar recognised by the system, the "Trailer : blind spot alert off" message displayed on the instrument panel informs you that the function is not operational. For information on the range of equipment adapted to your vehicle, we advise you to consult an approved Dealer.

Operating faults

If the system detects a fault, the message "Check Side radars" is displayed on the instrument panel. Consult an approved dealer.

ADDITIONAL DRIVING AID FUNCTIONS



Due to the presence of sensors behind the bumper, it is advisable to entrust any operation on the bumper (repair, replacement, paintwork, etc.) to a qualified professional.



– The system's detection range operates according to a standard lane width. If you are driving in wide traffic lanes, the system might not be able to detect a vehicle in the blind spot.

– The system might be disrupted momentarily if it is exposed to very poor weather conditions (heavy rain, snow etc.). Remain aware of driving conditions.

There is a risk of accidents.



This function is an additional driving aid. This function is not under any circumstances intended to replace the due care and attention of the driver, who should at all times be in control of the vehicle.

The driver should always adapt their speed to the traffic conditions, regardless of the system indications.

The system should under no circumstances be taken to be an obstacle detector or an anti-collision system.

System servicing/repairs

– In the event of an impact, radar alignment may be changed, and its operation will consequently be affected. Deactivate the function and consult an authorised dealer.

– Any work in the area where the radars are located (repairs, replacements, etc.) must be carried out by a qualified professional.

Only an authorised dealer is qualified to service the system.

System disturbance

Some conditions can disturb or damage the operation of the system, such as :

- complex surroundings (metal bridges, tunnels, roads with barriers at the edge, etc.) ;
- poor weather conditions (snow, hail, black ice, etc.).

Risk of false alarms or absence of warnings

In the event of the system behaving abnormally, deactivate it and consult an authorised dealer.

ADDITIONAL DRIVING AID FUNCTIONS



Limitation of the system operation

- The radar area should be kept clean and free of any modifications in order to ensure the proper operation of the system.
- Small objects moving close to the vehicle (motorcycles, bicycles, pedestrians, etc.) may not be recognised by the system.
- When turning into a bend, the radars may temporarily cease to detect vehicles in adjacent lanes.
- The function may warn you late if two other vehicles are approaching from the rear, driving side by side in the adjacent lanes (i.e. driving on a 3-lane road) at a much higher speed than your vehicle.
- The system may not provide a warning when the other vehicles are travelling at a significantly different speed.

- If the vehicle is being overtaken by a long vehicle (e.g. heavy goods vehicle overtaking at a similar speed to the vehicle) the system may interrupt the warning before the end of the manoeuvre.

- The vehicle is travelling on a winding road.

Deactivating the function

You must disable the function if:

- the radar area has been damaged (rear bumper);
- the vehicle is fitted with a towbar that is not recognised by the system.

Safe distance alert

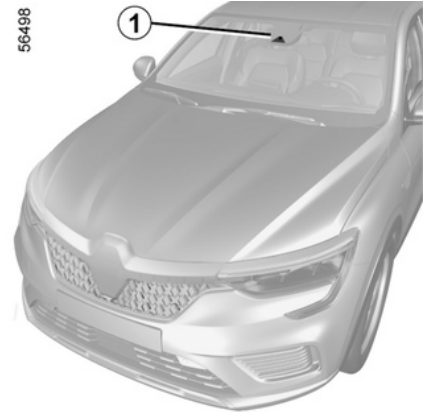

Using the information from the camera **1**, this function informs the driver of the time interval between their vehicle and the vehicle in front so that a safe stopping distance between the two vehicles can be maintained.

Note: ensure that the windscreen is not obscured (by dirt, mud, snow, condensation forming, etc.).

The function is activated when the vehicle speed is between about 19 and 124 mph (30 and 200 km/h).

ADDITIONAL DRIVING AID FUNCTIONS



This function is an additional driving aid. This function is not under any circumstances intended to replace the due care and attention of the driver, who should at all times be in control of the vehicle.

To activate or deactivate the function, refer to the multimedia instructions.

Select "ON" or "OFF".



Each time the vehicle is started, the function continues the mode saved the last time the engine was stopped.

Activating/deactivating the function

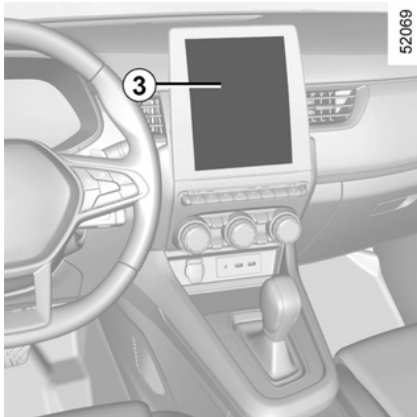

Vehicles fitted with a multimedia screen 3

Operation

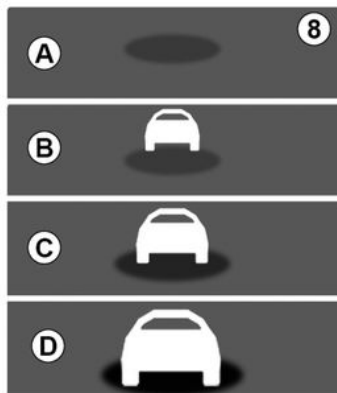

With the function activated, the **8** indicator is displayed on the instrument panel and informs the driver of

the distance between their vehicle and the vehicle in front.

- **A** (grey) : function not operational ;
- **A** (green) : no vehicle detected ;
- **B** (green) : the time interval is greater than or equal to around 2 seconds (distance between the two vehicles adapted to your speed) ;
- **C** (orange) : the time interval falls between around 1 and 2 seconds (insufficient distance between the two vehicles) ;
- **D** (red) : the time interval is less than or equal to around 1 second (very insufficient distance between the two vehicles).

If the interval between the two vehicles is less than approximately 0.5 seconds, the **8** indicator and the **D** display will flash in red on the instrument panel.

Under certain conditions, the time interval may not be displayed :

- while cornering ;
- when changing lane ;
- if the vehicle in front is sufficiently far or outside the range of the camera.

ADDITIONAL DRIVING AID FUNCTIONS



The measurement is displayed for information : the system does not carry out any action on the vehicle.

This function is not designed for use in urban conditions or for a dynamic driving style (sudden cornering, acceleration, braking, etc.), but rather for stable driving conditions.

The function does not interact with the braking system.

The camera zones must be kept clean and free of any tampering in order to ensure the proper operation of the system.

Any work carried out in the area where the camera is located (repairs, replacements, windscreen modifications, etc.) must be carried out by a qualified professional.



This function is an additional driving aid. This function is not under any circumstances intended to replace the due care and attention of the driver, who should at all times be in control of the vehicle.

System servicing/repairs

– In the event of an impact, the camera alignment may be changed and its operation may consequently be affected. Deactivate the function and consult an authorised dealer.

– Any work carried out in the area where the camera is located (replacements, repairs, windscreen modifications, etc.) must be carried out by a qualified professional.

Only an authorised dealer is qualified to service the system.

In the event of system disturbance

– obstruction of the windscreen (by dirt, glass, snow, condensation, etc.);

- a complex environment (metal bridge, tunnel etc.);
- poor weather conditions (snow, hail, black ice etc.);
- poor visibility (night, fog etc.);
- poor contrast between the vehicle preceding it and the surrounding area (e.g. white vehicle in a snowy area etc.);
- being dazzled (glaring sun, lights of vehicles travelling in the opposite direction etc.);
- the road is narrow, winding and undulating (tight bends etc.)

Risk of erroneous false alarms.

ADDITIONAL DRIVING AID FUNCTIONS

Active emergency braking

56488

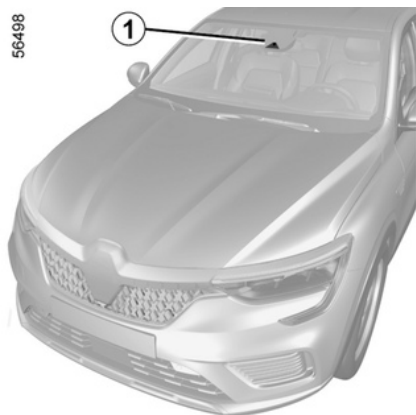

Using information from the radar **1**, the system calculates the distance which separates it from the vehicle in front and any surrounding pedestrians and cyclists.

The system informs the driver if there is a risk of head-on collision to enable appropriate emergency manoeuvres (pressing the brake pedal and/or turning the steering wheel).

Depending on the reactivity of the driver, the system can assist with braking in order to limit damage or prevent a collision.

Note : ensure that the windscreen is not obstructed (by dirt, mud, snow, condensation, number plate, etc.).

Location of the camera 1

Make sure the windscreen is not obscured (by dirt, snow, condensation, etc.)



This system can apply maximum braking to the vehicle until it is completely stationary if necessary.

For safety reasons, always wear your seat belt when travelling in your vehicle and make sure that it is loaded so that no items can be thrown forward and hit the occupants.



This function is an additional driving aid. This function is not under any circumstances intended to replace the due care and attention of the driver, who should at all times be in control of the vehicle.

Operation

Detection of vehicles

When driving, in the event of a risk of collision with the vehicle in front, the system will :

– **warn of the risk of collision** :

when the vehicle speed is between 4 mph (7 km/h) and 106 mph (170 km/h), the message “Brake” is displayed in red on the instrument panel **3**, accompanied by an audible warning.

If the driver depresses the brake pedal and the system still detects a risk of collision, the brake force is increased.

– **braking may be triggered** :

when the vehicle is moving slower than approximately 75 mph (120 km/h), if the driver doesn't respond to the warning and a collision is imminent.

ADDITIONAL DRIVING AID FUNCTIONS



If the vehicle stopped as a result of active emergency braking, the driver must keep the vehicle stationary by applying the brake pedal.

Note : if the driver uses the vehicle controls (steering wheel, pedals, etc.) the system may delay certain operations or not activate.

Special features of warnings

Depending on the speed, the warning and braking may be activated simultaneously.

Special features of stationary vehicles

Stationary vehicles are detected when your vehicle is being driven at a speed between approximately 4 mph (7 km/h) and 50 mph (80 km/h).

The system is not active and does not emit a warning for stationary vehicles when you exceed approximately 50 mph (80 km/h).

 In the event of emergency manoeuvre, you can stop braking at any moment

by :

- tapping the accelerator pedal;
- or
- turning the steering wheel as a collision avoidance manoeuvre.

Detection of pedestrians and cyclists

(depending on the vehicle)

When driving at a speed between approximately 4 mph (7 km/h) and 50 mph (80 km/h), if there is a risk of collision with a cyclist or pedestrian, the system :

- **warns you of a collision risk :**
 - the "Brake" message is displayed in red on the instrument panel **3**, accompanied by a sound signal.

If the driver depresses the brake pedal and the system still detects a risk of collision, the brake force is increased.

- **braking may be triggered :**

if the driver does not react following the alert and collision becomes imminent.



If the vehicle stopped as a result of active emergency braking, the driver must keep the vehicle stationary by applying the brake pedal.

Note : if the driver uses the vehicle controls (steering wheel, pedals, etc.) the system may delay certain operations or not activate.

Special features of warnings

ADDITIONAL DRIVING AID FUNCTIONS

Depending on the speed, the warning and braking may be activated simultaneously.



In the event of emergency manoeuvre, you can stop braking at any moment

by:

- tapping the accelerator pedal;

or

- turning the steering wheel as a collision avoidance manoeuvre.

Vehicle detection

Detection of vehicles travelling in the same lane

The risk of a collision with the vehicle in front of you in the same lane is detected by the system when:

- your vehicle is travelling at a speed between approximately 5 mph (8 km/h) and 112 mph (180 km/h).

Detection of oncoming vehicles in the context of a manoeuvre to change direction

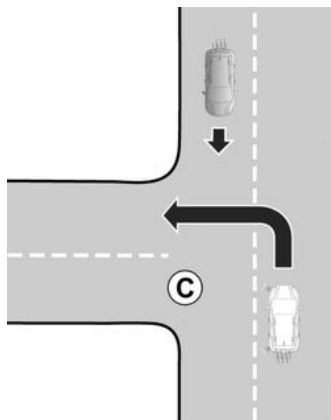

When you wish to change direction (e.g. **C**), oncoming vehicles are detected by the system when:

- your vehicle is travelling at a speed between approximately 5 mph (8 km/h) to 12 mph (20 km/h);
- you have activated the direction indicator light.

Detection of vehicles crossing the lane perpendicularly

Vehicles crossing the lane perpendicularly are detected by the system when:

- your vehicle is travelling at a speed between approximately 12 mph (20 km/h) and 37 mph (60 km/h).

Detection of vehicles stopped in the lane

Stationary vehicles are detected by the system when:

- your vehicle is travelling at a speed between approximately 5 mph (8 km/h) and 50 mph (80 km/h).

Activating or deactivating the system

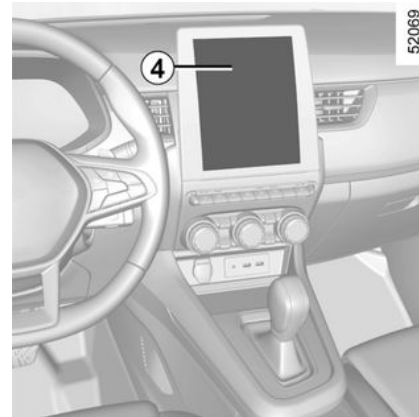

For vehicles fitted with a multimedia screen 4

To activate or deactivate the function, refer to the multimedia instructions.

Select "ON" or "OFF".

ADDITIONAL DRIVING AID FUNCTIONS

Activating and deactivating alerts using the "My Safety" button



The alerts can be deactivated or activated using "Perso" mode in the "My Safety" function.

If the alerts have previously been deactivated using "Perso" mode:

- **to deactivate the alerts**, press the button **5** twice;
- **to reactivate alerts**, press the button **5** once.



This system is reactivated each time the ignition is switched on.

Temporarily not available

If the system detects a temporary

fault the  warning light illuminates, or depending on the vehicle,





the  warning light illuminates on the instrument panel.

The possible causes are :

- the system is temporarily blinded (glare from the sun, dipped beam headlights, bad weather conditions etc.). The system will be operational again when visibility conditions are better ;
- the system is temporarily interrupted (e.g. the windscreen is obscured by dirt, mud, snow, condensation, etc.). In this case, park the vehicle and switch off the engine. Clean the windscreen. When you next start the engine, the warning light and the message go out.

If this is not the case, this may arise from another cause ; contact an Approved Dealer.

Operating faults

 and  or, depending on the vehicle,  and  illuminates on the instrument panel :

this indicates that the system has detected an operating fault. Consult an approved dealer.

ADDITIONAL DRIVING AID FUNCTIONS



Active emergency braking

This function is an additional driving aid. This function is not under any circumstances intended to replace the due care and attention of the driver, who should at all times be in control of the vehicle. The triggering of this function may be delayed or prevented when the system detects clear signs of control of the vehicle by the driver (action on the steering wheel, pedals etc.). The system cannot be activated:

- when the lever of gearbox is in neutral or the clutch pedal has been pressed down for approximately 10 seconds;
- when the parking brake is activated;
- when the Electronic Stability Program (ESC) has started.

System servicing/repairs

- In the event of an impact, the radar and/or camera alignment may be changed and its operation may consequently be affected. Deactivate the function and consult an authorised dealer.

- Any work in the area where the radar and/or camera is located (repairs, replacements, windscreen modifications, etc.) must be carried out by a qualified professional.

Only an authorised dealer is qualified to service the system.



System disturbance

Some conditions can disturb or damage the operation of the system, such as:

- a complex environment (metal bridge, tunnel etc.);
- poor weather conditions (snow, hail, black ice etc.);
- poor visibility (night, fog etc.);
- poor contrast between the object (vehicle, pedestrian etc.) and the surrounding area (e.g. pedestrian dressed in white located in a snowy area etc.);
- being dazzled (glaring sun, lights of vehicles travelling in the opposite direction etc.);
- windscreen obscured (by dirt, ice, snow, condensation etc.);
- ...

In these conditions, the system may not react or may brake inadvertently.

Limitation of the system operation

ADDITIONAL DRIVING AID FUNCTIONS

- Each time the vehicle is started, the system carries out a calibration according to the vehicle surroundings and may be inactive for a length of time between approximately two and five minutes ;
- A vehicle travelling in the opposite direction will not trigger any alert or affect operation of the system ;
- The radar and camera zones must be kept clean and free of any tampering in order to ensure the proper operation of the system ;
- the system may not respond to small vehicles such as motor-bikes as effectively as to other vehicles ;
- the system may not operate properly when the road surface is slippery (rain, snow, black ice, etc.) ;
- to ensure correct operation, the system needs to distinguish the complete outline of the pedestrian. So the system cannot detect :
 - pedestrians in the darkness or in poor lighting conditions ;

- partially visible pedestrians :
 - pedestrians less than approximately 80 cm tall ;
 - pedestrians carrying large objects ;
 - ...

In these conditions, the system may not react or may brake inadvertently.



Deactivating the function

You must disable the function if :

- the area of the camera has been damaged (on the wind-screen side or the interior rear-view mirror side) ;
- the vehicle is being towed (breakdowns) ;
- the windscreen is cracked or distorted (do not carry out wind-screen repairs in this area ; have it changed by an approved dealer) ;
- you are not driving on a paved road.

In the event of the system behaving abnormally, deactivate it and consult an authorised dealer.

Halting the function

You can halt the active braking function at any time by tapping the accelerator pedal or by turning the steering wheel in a collision avoidance manoeuvre.

ADDITIONAL DRIVING AID FUNCTIONS

Driver vigilance warning

The driver vigilance warning is a function that analyses the behaviour of the driver (driving style, vehicle steering, etc.) and alerts them if there is a risk of falling asleep.

It takes into account indicators such as:

- steering wheel movements;
- driver actions on other systems (indicators, brake pedal, etc.).



This function is an additional driving aid in case of risk of fatigue.

The function does not operate on the vehicle. The function cannot, under any circumstances, replace the driver's responsibility during driving.

The driver must always adapt their driving according to their alertness, regardless of the system's indications.

Warning activation/deactivation



For safety reasons, carry out any adjustments while the vehicle is stationary.



Depending on the vehicle, depending on the length of time following the last time the engine was stopped, the alerts are reactivated:

- when the vehicle is unlocked;
- or
- when a door is opened;
- or
- when the engine is restarted.



When the alerts are deactivated, the system continues to assess the driver's state of fatigue.

Activating and deactivating the alerts from the multimedia screen 7

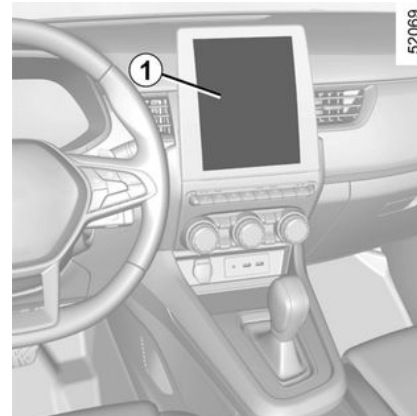

To activate or deactivate the alerts, please refer to the multimedia instructions.

Select **"ON"** or **"OFF"**.

ADDITIONAL DRIVING AID FUNCTIONS

Activating and deactivating alerts using the "My Safety" button



The alerts can be deactivated or activated using "Perso" mode in the "My Safety" function.

If the alerts have previously been deactivated using "Perso" mode:

- **to deactivate the alerts**, press the button **2** twice;
- **to reactivate alerts**, press the button **2** once.

Operation

The function is set to notify the driver if:

- a few minutes have elapsed since the vehicle last stopped;
- the vehicle speed is greater than approximately 43 mph (70 km/h).

The system assesses repeated signs of driver fatigue on the steering wheel.

When a risk of fatigue is detected, the "Vigilance alert Have a break" message is displayed on the instrument panel accompanied by a beep.

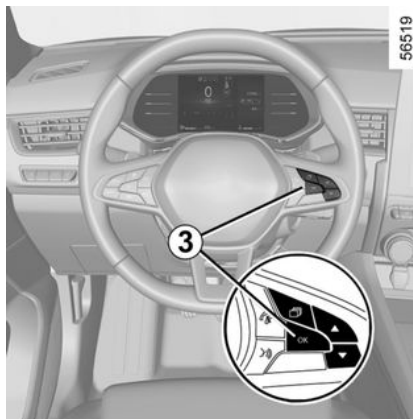

Press the button OK **3** on the steering wheel to clear the alert. It is advisable to stop as soon as possible for a break.

After deleting the message, the system continues vigilance monitoring

and issues a new warning if necessary.

i The driver vigilance warning constantly monitors the driver's attention and can provide several warnings per journey. The system resets every time the engine is started.

i Warnings can be deactivated. In this case, the system continues to assess the driver's state of fatigue. Warnings are automatically reactivated with each new journey.

After deleting the message, the system continues vigilance monitoring and issues a new warning if necessary.

ADDITIONAL DRIVING AID FUNCTIONS

Limitation of the system operation

Some conditions can disrupt or damage the system operation, for example:

- certain driving styles (incorrect driving etc.);
- driving on a road in poor condition;
- strong side wind;
- The clock is wrongly configured (depending on vehicle);
- winding roads;
- trailer traction.

Operating faults

If the system detects a fault, the "Check Fatigue Warning System

message and the  warning light are displayed on the instrument panel.

Have the system checked by an authorised dealer.

Detection of road signs

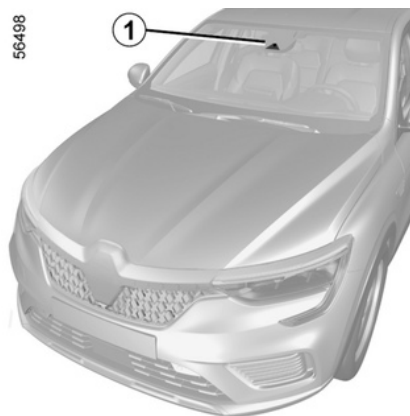

The system displays speed limits on the instrument panel according to road signs detected on the side of the road.

It mainly uses information taken from the camera **1**, attached to the windscreen behind the rear view mirror.

Depending on the country, the system also uses information from a map subscription to interpret certain signs (town entrance, etc.).

The sign displayed on the instrument panel changes when a road sign is detected by the system.

Once the speed limiter or the cruise control is activated, you can adapt the limited speed setpoint to the speed displayed on the instrument panel using the system. (→ **202**, → **205**)

If the limited speed limit is exceeded, the road sign displayed on the instrument panel is modified to inform the driver.

Location of the camera **1**

Make sure the windscreen is not obscured (dirt, mud, snow, condensation etc.).

Special features

For vehicles with a map subscription:

- if the vehicle is travelling in a country where the speed units differ from those of the vehicle, the system displays the speed limit sign in the unit of the country, alongside the speed limit converted to the unit used by the vehicle's instrument panel;
- for countries where the speed limit is reduced during rainy weather on some types of roads, the system may alter the detected speed limit after a few seconds of the windscreen wipers being activated.

For vehicles without a map subscription: when driving in a country where speed units differ from those on your

ADDITIONAL DRIVING AID FUNCTIONS

vehicle, you can manually select the speed unit shown on the instrument panel (e.g. change the unit from miles to kilometres) in order to display accurate information. → 100

Note: the system does not take into account exceptional speed limit measures, such as peak pollution days.

Activating/deactivating the system

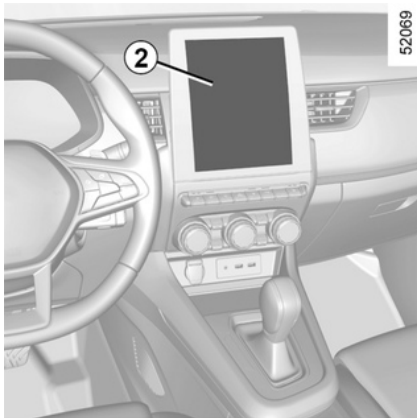

Vehicles fitted with a multimedia screen 2

To activate or deactivate the function, refer to the multimedia instructions.

Select "ON" or "OFF".



For safety reasons, carry out any adjustments while the vehicle is stationary.



Depending on the vehicle, depending on the length of time following the last time the engine was stopped, the sound alert is reactivated:

- when the vehicle is unlocked;
- or
- when a door is opened;
- or
- when the engine is restarted.

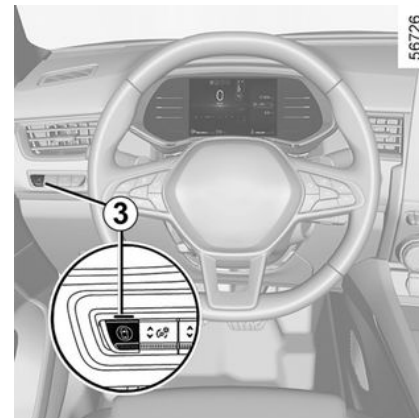

Activating, deactivating overspeed sound alerts using the "My Safety" button 3

The sound alert can be deactivated or activated using "Perso" mode in the function. → 165

If the sound alert has previously been deactivated using "Perso" mode:

- **to deactivate the sound alert**, press the button 3 twice in succession. The indicator light on the button 3 goes out;
- **to reactivate the sound alert**, press the button 3 once. The indicator light on the button 3 lights up.

ADDITIONAL DRIVING AID FUNCTIONS

Operation

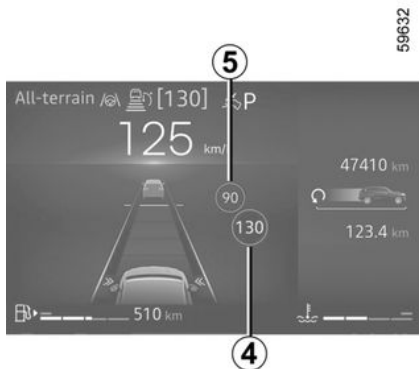

Warning lights

The function displays the following warning lights :

4 Speed limit road signs

5 Additional road signs (start or end of "No overtaking" zone, slip road speed limit, speed in case of a caravan, speed limit with length of application, etc.)

If the speed limit is exceeded, the circle around the panel flashes (**4** warning light) along with a sound signal to warn the driver.



Map subscription

Road sign detection is associated with a map subscription.

Depending on the equipment, it is necessary to update the maps regularly.

If the maps are not updated, system performance will be impaired (incorrect speed limit, etc.)

Note: If there is no map for a country, a message will appear on the multimedia screen to inform and for downloading the map information relating to the country.

To manage the subscription, please refer to the multimedia instructions.

If there is no subscription, the system will be limited to taking into account the speed limit signs when they are detected by the camera.

The system will no longer take into account information related to the maps. The speed limit availability may be affected.

Varying the limit speed

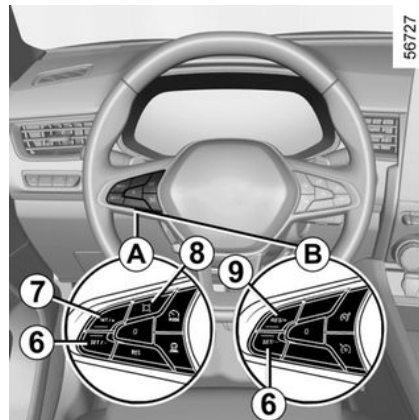

Depending on the vehicle, you have control **A** or **B**.

If the speed limit notification differs from the detected speed value, press and hold the following buttons :

- **7** (SET/+) or **9** (RES/+) to increase the notification speed to the detected speed ;
- **6** (SET/-) to reduce the notification speed to the detected speed.

Variation of the limited speed or cruising speed

To adapt the speed limiter, cruise control or adaptive cruise control

ADDITIONAL DRIVING AID FUNCTIONS

setpoint to the detected speed limit, press the button **B**.

Temporary unavailability

If the system is unavailable for reasons related to the camera or map

data, the  symbol or, depend-

ing on the vehicle, the  symbol is displayed on the instrument panel.

If there is still a problem, contact an approved dealer.

The system cannot detect the speed limit if:

- the windscreen is not clean;
- the camera is blinded by the sun;
- there is insufficient visibility (fog, etc.);
- the signs are not legible (snow, etc.) or are hidden (by another vehicle or by trees);
- the information taken from the map is not up to date.



when the front camera is obscured, the "Front camera no visibility" message is displayed on the instrument panel. Clean the windscreen area in front of the camera.

Operating faults

When the system detects an operating fault, the  or, depending on

the vehicle, symbol  is displayed on the instrument panel.



This function is an additional driving aid. This function is not under any circumstances intended to replace the due care

and attention of the driver, who should at all times be in control of the vehicle.

The driver should always adapt their speed to the traffic conditions, regardless of the system indications.

The system detects speed limit signs and does not detect other signs (e.g. entry/exit to/from urban areas, etc.).

The system may not detect all speed limit signs or may interpret them incorrectly.

The driver should not ignore signs that are not detected by the system and should, as a priority, comply with the traffic signage and the highway code. In the event of poor visibility (fog, snow, frost, etc.), it is possible that the system may not indicate the correct speed to the driver.

ADDITIONAL DRIVING AID FUNCTIONS

The driver should always adapt their speed to the traffic conditions, regardless of the system indications.

3

Active driver assist

The 'Active driver assist' is a driving aid system designed for use on long motorway journeys, where traffic is flowing or in jams.

This system comprises the "Stop and Go **Adaptive cruise control function**" → 208 and the "Lane Centring" function.

The system allows the driver to :

- maintain vehicle speed based on a previously saved speed ;
- adjust the distance between this vehicle and the vehicle in front ;
- direct the vehicle to the centre of the lane ;
- adapt the vehicle speed to the speed shown on the road signs, automatically or after confirmation by the driver (depending on the vehicle).



Important : you should keep your feet near the pedals and your hands on the steering wheel at all times to prepare for any event.

The "Stop and Go adaptive cruise control" function

Based on information from a camera, the Stop and Go adaptive cruise control function gives you the option of maintaining a selected speed, known as the cruising speed, while keeping a safe distance from the vehicle in front in the same lane.

If the vehicle in front stops, the Stop and Go adaptive cruise control can brake your vehicle to a complete stop before setting off again.

The system controls acceleration and deceleration of your vehicle using the engine and braking system.

The "Stop and Go adaptive cruise control" function can be activated from 0 to 99 mph (0 to 160 km/h) according to conditions on the road (traffic, weather, etc.).

It is represented by the following

symbol  or  → 208.

Note :

- the driver must observe the maximum speed limit and safe distances in the country where they are driving ;
- the Stop and Go adaptive cruise control can brake the vehicle up to a third of the braking capacity. Depending on the situation, the driver may need to brake harder.



The Stop and Go adaptive cruise control does not trigger an emergency stop and its braking capability is limited.

The "Lane centring" function

Using information from a camera, the "Lane Centring" function manipulates the steering system to direct the vehicle to the middle of the lane.

If the conditions allow it, the function is available between :

- 0 mph and 99 mph (0 and 160 km/h) approximately with a vehicle in front ;
- or
- 37 mph (60 km/h) and 99 mph (160 km/h) approximately without a vehicle in front.

ADDITIONAL DRIVING AID FUNCTIONS

The "Lane Centring" function is a comfort feature. It is represented by

the symbol .

Note : in the event of a sharp bend, the function's lateral retention capacities are limited and require the driver to take immediate action on the steering wheel. The camera zone must be kept clean and free of any tapering in order to ensure the proper operation of the system.

Additional information

Depending on the vehicle, the "Active driver assist" function may be used with other driving aid functions.

Please note that :

- the system cannot be activated when the "Park Assist" function is active ;
- When the "Lane Centring" function is in operation mode, this will suspend the "Lane departure prevention" function if it has already been activated. When the "Lane Centring" function is not controlling the steering system, the "Lane departure prevention" function may be reactivated if conditions allow.

ADDITIONAL DRIVING AID FUNCTIONS

Location of components

66733

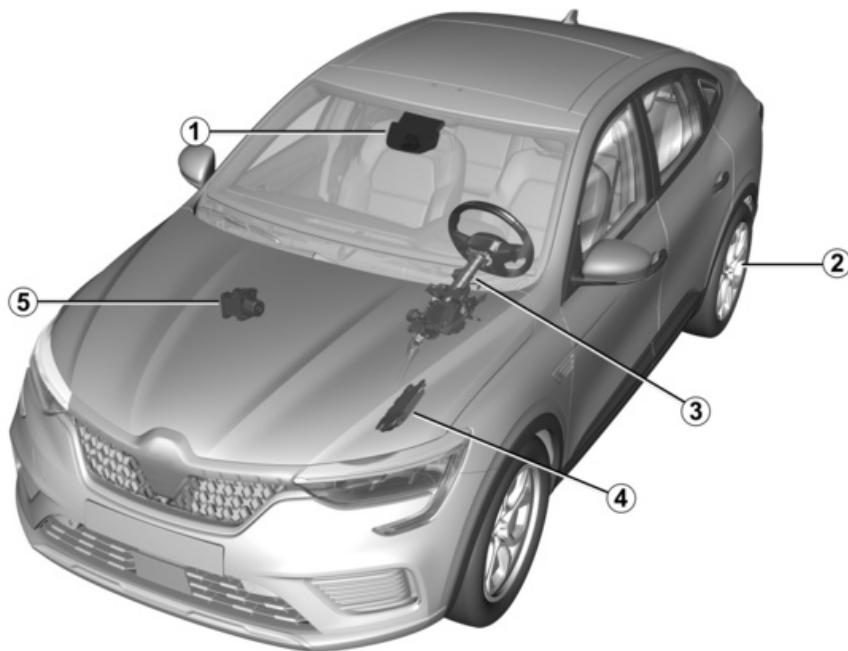

3

ADDITIONAL DRIVING AID FUNCTIONS

1 Camera

Detects markings on the ground and the position of vehicles on the various traffic lanes.

Calculates the distance between your vehicle and the vehicle in front.

The system's maximum range is approximately 140 metres. This may vary according to the road conditions (ground relief, weather conditions, etc.).

Amongst other things, it controls the system activation/deactivation parameters (door opening status, etc.).

Make sure the windscreen is not obscured (by dirt, mud, snow, etc.).



The camera zones must be kept clean and free of any tampering in order to ensure the proper operation of the system.

2 Electronic parking brake

Keeps the vehicle stationary under certain conditions.

3 Power-assisted steering

Operates the front wheels to assist the trajectory of your vehicle according to details transmitted by the 1 computer. It also enables detection of the driver's hands on the steering wheel.

4 Engine computer

It controls and directs the engine to carry out the required acceleration.

5 Active vehicle control

This system provides information on vehicle dynamics to the computer 1 (speed, lateral acceleration etc.) and acts on the braking system to control deceleration and to keep the vehicle stationary.

ADDITIONAL DRIVING AID FUNCTIONS

Controls description

6 Selects/deselects the driving aids, depending on the vehicle:

- Active driver assist;
- stop and go adaptive cruise control;
- speed limiter;
- off.

7 Adjusts the following distance

8 Recalls the stored cruising speed (RES)

9 Activates, decreases cruising speed or stores the current speed (SET/-)

10 Activates, increases cruising speed or stores the current speed (SET/+).

11 Puts the function on standby (with cruising speed stored) (0)

12 (depending on the vehicle) Adapts the speed setpoint to detected speed limits

Displays on the instrument panel

13 Stored cruising speed

14 "Stop and Go adaptive cruise control" function indicator light



15 "Lane Centring" function warning

light

16 Vehicle in front

17 Stored safe distance

18 Left-hand and right-hand line indicators

19 Hands off steering wheel detection warning light

20 Steering wheel

The driver must always keep their hands on the steering wheel. If too much force is applied when turning the steering wheel, the "Lane Centring" function is put on standby so the driver can regain control of the vehicle.

Under certain conditions (sharp bends, etc.) a vibration may be triggered on the steering wheel to warn the driver that they must regain control of the vehicle.

If the driver does not handle the steering wheel (no hands are detected) the "Lane centring" function is deactivated after several alerts.

Activating, deactivating the "Active driver assist" function

Activating the function

To activate the function, press the button **6** as many times as necessary to activate it.

The message "Lane Centering on hold" appears on the instrument panel, and the indicator light **14**, the warning light **15** and the left-hand and right-hand line indicators **18** are displayed in grey, accompanied by dashes to indicate the cruise control function is waiting to store a cruising speed.

Then press the switches **9** (SET/-) or **10** (SET/+) to activate the "Stop and Go Adaptive cruise control function" and store the current speed.

After all the activation conditions are met, the "Active driver assist", consisting of the "Stop and Go Adaptive cruise control" and the "Lane centering" function, is then activated.

The green warning light **15** and the left-hand and right-hand line indicators **18** are displayed on the instrument panel to confirm that the function is in operation and directing your vehicle towards the centre of the lane.

You can interrupt the "Lane Centring" function at any time by forcefully turning the steering wheel. As soon as you stop turning the steer-

ADDITIONAL DRIVING AID FUNCTIONS

ing wheel, the "Lane Centring" function is reactivated.

 you must keep your hands on the steering wheel when using the "Lane Centring" function. Under no circumstances should you take your hands off the steering wheel.

Deactivating the function

Press the button **6**. The "Lane centering" function goes to deactivate and the "Stop and Go adaptive cruise control function" goes to standby with current cruising speed stored. Deactivation of the "Lane centering" function is confirmed by the disappearance of the warning light **15** and the right-hand and left-hand line indicators **18** from the instrument panel.

 if the "Lane departure prevention" function was previously activated and the conditions allow, it will automatically reactivate.

 After deactivating the "Active driver assist" function, you need to press switch **8** (RES) in order to use the "Stop and Go Adaptive cruise control" function with the stored cruising speed.

"Lane Centring" function on standby

The "Lane Centring" function is put on standby automatically when :

- the system no longer detects the lines or only one line is detected in your lane ;
- the lane is too narrow or too wide ;
- the system does not detect any hands on the steering wheel ;
- in some driving conditions (roundabout, intersection, the bend is too sharp, etc.) ;
- the vehicle speed is greater than approximately 99mph (160km/h) ;
- the vehicle speed is below approximately 30 mph (48 km/h), without a vehicle in front ;
- the vehicle crosses a line ;
- the system is temporarily disrupted (for example: camera obscured by dirt, mud, snow, condensation, etc.).

Certain actions carried out by the driver also suspend the "Lane Centring" function :

- activating the indicators ;
- too much force is used when handling the steering wheel.

Standby of the function is confirmed

by the **15**  warning light and the left-hand and right-hand line indicators **18** appearing in grey on the instrument panel.



Important : you should keep your feet near the pedals and your hands on the steering wheel at all times to prepare for any event.

Once the conditions are met, the function again directs the vehicle to

the centre of the lane. The **15**  warning light and left-hand and right-hand line indicators **18** are displayed in green on the instrument panel.

ADDITIONAL DRIVING AID FUNCTIONS



You can affect **the vehicle trajectory** at any point by turning the steering wheel.

“Keep hands on steering wheel” alert

When the “Lane Centring” function no longer detects your hands on the steering wheel, several warning levels will be triggered :

- **after approximately 13.5 seconds**, the message : “Keep hands on steering wheel” is displayed in yellow on the instrument panel ;
- **after approximately 25.5 seconds**, the message : “Keep hands on steering wheel” and the warning light



19 appears in red on the instrument panel, accompanied by a gradually increasing sound signal ;

- **after approximately 45.5 seconds**, **the sound of the audio system will be reduced, the audible signal sounds continually, the warning light 19**



15 is switched off and the message “Lane centering deactivated” appears in red on the instrument panel : the “Lane Centring” function is deactivated. To reactivate the

function, Press the button, 6 as many times as necessary to select “Active driver assist” again.

Note : in some situations, the “Lane Centring” function may no longer detect your hands on the steering wheel and may sound a signal :

- the vehicle is moving along a long straight lane and the driver’s hands are immobile on the steering wheel ;
- the driver is holding the steering wheel very lightly ;
- ...

If the “Lane Centring” function is deactivated due to the driver’s hands not being detected on the steering wheel, the Stop and Go adaptive cruise control function continues to operate.



In the first two alert levels, when the system again detects the presence of the driver’s hands on the steering wheel, the system stops the alerts. The function continues to direct the vehicle to the centre of the lane.

In the case of a sharp bend



44639

3

In the case of a sharp bend, and depending on the vehicle speed, the function’s side retaining capacities will be limited and require the driver to carry out immediate action on the steering wheel so that the function can continue to maintain the vehicle in the centre of the lane.

If the driver does not intervene, the function triggers a vibration on the steering wheel to signal that the vehicle is about to cross a line and that the driver needs to carry out immediate action.

The **15**  warning light and the left-hand or right-hand line indicator

ADDITIONAL DRIVING AID FUNCTIONS

18 appear in red on the instrument panel.

If the vehicle crosses a line completely and moves out of lane or if the bend is too sharp, the "Lane Centring" function is put on standby.

The function is confirmed to be on

standby the warning light **15**  and the left-hand and right-hand line indicators **18** appearing in grey on the instrument panel.

Operating faults

If an operating fault is detected by the lane centering function, the message "Check lane centering" is displayed on the instrument panel and the function is deactivated.

The Stop and Go adaptive cruise control function can remain operation.

Consult an approved dealer.

If a "Stop and Go adaptive cruise control" function operating fault is detected, the "Check Adaptive Cruise control" message appears on the instrument panel and both the "Stop and Go adaptive cruise control" function and the "Lane Centring" function are interrupted.

Consult an approved dealer.

If an operating fault is detected on one or more components of the "Active Driver Assist" system, the



warning light appears on the instrument panel, alongside, depending on the nature of the fault, the message :

- "Check front camera";
- "Check camera/radar";
- "Check vehicle".

The Active Driver Assist system is deactivated.

Consult an approved dealer.



The "Active Driver Assist" function is an additional driving aid. This system does not take

the place of the driver.

Therefore, it can under no circumstances replace the driver's responsibility to respect speed limits and safe distances and to be vigilant (the driver must always be ready to brake). The driver must always be in control of the vehicle. The driver must always adapt their trajectory and speed according to the surroundings and traffic conditions regardless of system indications.

The "Active Driver Assist" uses the "Stop and Go adaptive cruise control" function and the "Lane Centring" function. It must only be used on a motorway or multi-lane road (separated by a barrier).

ADDITIONAL DRIVING AID FUNCTIONS

Except for lines delimiting lanes and the speed limit signs within the limits of the system's detection capacity, the road sign information (other traffic signs, traffic lights, pedestrian crossings, etc.) are not recognised by the system. These do not trigger any alert or reaction by the system.

The "Active driver assist" uses the "Stop and Go adaptive cruise control" and "Lane Centring" functions. The system should under no circumstances be taken to be an obstacle detector or an anti-collision system.

Use the "Active driver assist" exclusively outside built-up areas, on wide roads with visible lines.

It must not be used in heavy traffic, on winding or slippery roads (black ice, aquaplaning, gravel) or during bad weather (fog, rain, side winds etc.).

There is a risk of accidents.



System servicing/repairs

- In the event of an impact, the camera alignment may be changed and its operation may consequently be affected. Deactivate the system and consult an authorised dealer.

- Any work in the proximity of the camera (replacements, repairs, windscreen modifications, paintwork etc.) must be carried out by a qualified professional.

Only an authorised dealer is qualified to service the system.



Deactivating the system

You must deactivate the system if :

- the vehicle is travelling on a windy road ;
- the vehicle is being towed (breakdowns) ;
- the vehicle is being driven with an emergency spare wheel ;
- the vehicle is towing a trailer or a caravan ;
- the vehicle is being driven in a tunnel or close to a metallic structure ;
- the vehicle arrives at a toll point, a roadwork area or on a narrow lane ;
- the vehicle is being driven onto a highway entrance ramp ;
- the vehicle is being driven up or down a very steep slope ;
- the visibility is poor (glaring sun, fog etc.) ;
- the weather conditions are poor (rain, snow, side winds, etc.) ;

ADDITIONAL DRIVING AID FUNCTIONS

3

- the vehicle is being driven on a slippery road surface (rain, snow, gravel, etc.);
- the area of the camera has been damaged (e.g. on the inside or outside of the windscreen);
- the windscreen is cracked or distorted;

In the event of the system behaving abnormally, deactivate it and consult an authorised dealer.



Some conditions can disrupt or damage the operation of the system, for example :

- obstruction of the windscreen area (by dirt, ice, snow, condensation etc.) Frequently check the cleanliness and condition of the windscreen, front wiper blades ;
- a complex environment (tunnel etc.) ;
- poor weather conditions (snow, heavy rain, hail, black ice, etc.) ;
- poor visibility (night, fog etc.) ;
- poor contrast between the vehicle preceding it and the surrounding area (e.g. white vehicle in a snowy area etc.) ;
- being dazzled (glaring sun, lights of vehicles travelling in the opposite direction etc.) ;
- narrow, winding or undulating road (tight bends etc.) ;
- the tar lines detected as a line by the system ;
- narrowing/widening lanes ;

- road markings which are worn, lacking in contrast or very widely spaced from one another (lines partially erased etc.) ;
- multiple markings on the road (roadworks area, slip roads connecting to adjacent motorways, hard shoulder etc.) ;
- a vehicle with a significant difference in speed ;
- use of mats not adapted to the vehicle. On the driver's side, only use mats suitable for the vehicle, attached with the pre-fitted components, and check the fitting regularly. Do not lay one mat on top of another.

There is a risk of wedging the pedals ;

- Depending on the vehicle, an area with low connectivity that makes it impossible to geolocate the vehicle, or maps that are not up to date.

In these cases, the system may wrongly intervene.

- **Risk of unwanted braking or acceleration.**

ADDITIONAL DRIVING AID FUNCTIONS

- **Risk of unwanted, incorrect correction or no correction of trajectory.**

Many unforeseen situations may affect the system operation. Certain objects or vehicles that can appear in the camera detection zone may be interpreted by the system incorrectly, possibly leading to inappropriate acceleration or braking.

You should always be attentive to sudden events that might occur while you are driving. Always maintain your vehicle under control by keeping your feet near the pedals and your hands on the steering wheel, so that you are ready to act in any event.

SPEED LIMITER



The speed limiter function controls the engine to help you not to exceed a driving speed that you have chosen, known as the **limit speed**.

The speed limiter function can be activated from 0 mph to 112 mph (180 km/h).

Controls

Depending on the vehicle, you have control **A** or **B**.

1 activates the function and decreases the limit speed or stores the current speed (SET/-).

2 activates the function and increases the limit speed or stores the current speed (SET/+).

3 Depending on the vehicle, adapts the speed setpoint to detect speed

limits

4 Selects and deselects the driving aids, depending on the vehicle :

- Active driver assist (depending on the vehicle);
- Stop and Go Adaptive cruise control or cruise control (depending on the vehicle);
- Speed limiter;
- Off.

5 Put the function on standby (with limited speed stored) (0)

6 Recall the stored limit speed (RES)

7 Activates and increases the limit speed or to set the stored limit speed (RES/+)

8 Speed limiter On/Off

9 Cruise control On/Off

Depending on the vehicle, you can link the speed limiter function to the "Road sign detection" function → **186** by pressing the button **3** or button **7** long.

Driving

When a limit speed has been set but not yet reached, driving is similar to driving a vehicle without the speed limiter function.

Once you have reached the stored speed, no effort on the accelerator pedal will allow you to exceed the programmed speed except in an emergency (refer to information on "Exceeding the limit speed").

Switching on

Press switch **4** or **8**. The **10** warning light or appears in grey.

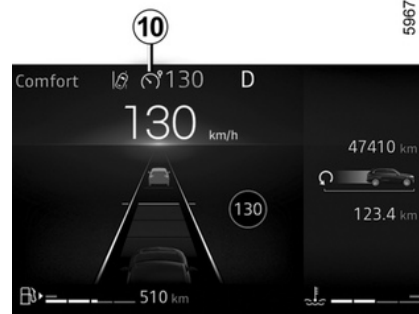

SPEED LIMITER

The "Speed limiter ON" message appears on the instrument panel accompanied by dashes to indicate that the speed limiter function is in operation, waiting to store a limit speed.

To store the current speed, press the **7** switch (RES/+) or the **1** switch (SET/-) or the **2** switch (SET/+): the limit speed replaces the dashes and, depending on the vehicle, the **10** warning light appears in white.

The minimum stored speed is 20 mph (30 km/h).

Varying the limit speed

The limit speed may be changed by pressing repeatedly or holding down:

- button **2** (SET/+) or **7** (RES/+) to increase speed ;
- button **1** (SET/-) to reduce speed.

Exceeding the limit speed

It is possible to exceed the limit speed at any time. To do this : press the accelerator pedal **firmly and fully** (beyond the resistance point).

While the speed is being exceeded, the speed limiter flashes red on the instrument panel. Then, release the accelerator pedal : the speed limiter function will return as soon as you

reach a speed lower than the memorised speed.



If the speed limiter is not available (after several attempts to activate), contact an approved dealer.

Limited speed cannot be maintained

When driving down a steep gradient, the system may not maintain the limit speed : the limit speed flashes in red on the instrument panel and an audible signal sounds at regular intervals to inform you of this situation.



You must keep your feet close to the pedals to be ready to react in an emergency.

Putting the function on standby

The speed limiter function is suspended when you press button **5** (0). The limit speed is stored and dis-

played in grey on the instrument panel.

Recalling the limit speed

If a speed has been stored, it can be recalled by pressing the button **6** or **7**.





When the speed limiter is set to standby, pressing the button **1**(SET/-) or **2** (SET/+) or **7** (RES/+) reactivates the function without taking into account the memorised speed : the speed at which the vehicle is moving is taken into account.

Switching off the function

The speed limiter function is interrupted when:

- you press the button **8** or **4** until the OFF appears on the instrument panel. In this case, the speed is no longer stored ;
- you press the button **9** or **4** until

warning light  or  appears on the instrument panel. In this case the cruise control is selected and there is no stored speed.

SPEED LIMITER

The **10** warning light  or  disappears from the instrument panel to confirm that the function is disabled.

3

CRUISE CONTROL



The cruise control function helps you to maintain your driving speed at a speed that you choose, called the **cruising speed**.

The cruise control function can be activated from 20 mph (30 km/h) to 112 mph (180 km/h).

Controls

Depending on the vehicle, you have control **A** or **B**.

1 activates the function and decreases the cruising speed or stores the current speed (SET/-).

2 activates the function and increases the cruising speed or stores the current speed (SET/+).

3 Depending on the vehicle, adapts the speed setpoint to detect speed

limits

4 Selects and deselects the driving aids, depending on the vehicle :

- Active driver assist (depending on the vehicle);
- Stop and Go adaptive cruise control or cruise control (depending on the vehicle);
- Speed limiter;
- Off.

5 Put the function on standby (with cruising speed stored) (0)

6 Recall the stored cruising speed (RES)

7 Activates and increases the cruising speed or to set the stored cruising speed (RES/+)

8 Speed limiter On/Off

9 Cruise control On/Off



Depending on the vehicle, you can link the cruise control function to the "Road sign detection" function
→ **186** by pressing the button **3**.



This function is an additional driving aid.

It can under no circumstances replace the driver's responsibility to respect speed limits and to be vigilant. The driver must always be in control of the vehicle.

Cruise control must not be used in heavy traffic, on undulating or slippery roads (black ice, aquaplaning, gravel) and during bad weather (fog, rain, side winds etc.).

There is a risk of accidents.

Switching on

Press button **4** as many times as necessary to select the cruise control or press button **9**.

The **10** warning light or appears in grey.

The "Cruise control ON" message appears on the instrument panel accompanied by dashes to indicate that the cruise control function is in operation and waiting to memorise a cruising speed.

CRUISE CONTROL

Activating cruise control

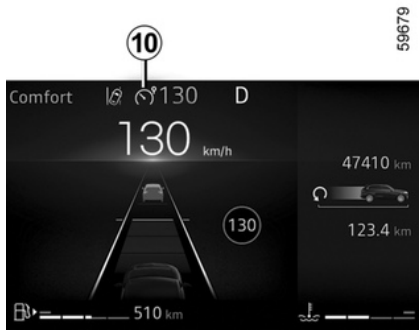

At a steady speed above approximately 20 mph (30 km/h), press the button **1** (SET/-) or **2** (SET/+) or **7** (RES/+): the function is activated and the current speed is taken into account.

The cruising speed replaces the dashes. Cruise control is confirmed when the memorised speed and warning light appear in green **10**



If you try to activate the function below 20 mph (30 km/h), the message "Invalid Speed" will be displayed and the function will remain inactive.

Driving

Once a cruising speed is registered and the cruise control function is active, you may lift your foot off the accelerator pedal.

Adjusting the cruising speed

The cruising speed may be changed by pressing the following repeatedly:

- the button **1** (SET/-) to reduce the speed;
- the button **2** (SET/+) or **7** (RES/+) to increase the speed.

Note : press and hold one of the switches to modify speed by successive increments.

Exceeding the cruising speed

The cruising speed may be exceeded at any time by pressing the accelerator pedal.

While it is being exceeded, the cruising speed flashes in red on the instrument panel. Then, release the accelerator pedal : after a few seconds, the vehicle will automatically return to its set cruising speed.

Cruising speed cannot be maintained

When driving down a steep gradient, the system may be unable to main-

tain the cruising speed : the memorised speed will flash in red on the instrument panel to inform you of this situation.



If the cruise control is no longer available (after several attempts to activate it), contact an Approved Dealer.



You must keep your feet close to the pedals to be ready to react in an emergency.

Putting the function on standby

The function is set to standby if you :

- press button **5** (0) ;
- press the brake pedal ;
- shift into neutral position (N).

The cruising speed is stored and displayed in grey on the instrument panel.

Returning to the cruising speed

If a speed is stored, it can be recalled, once you are sure that the

CRUISE CONTROL

road conditions are suitable (traffic, road surface, weather conditions, etc.). Press the button **6** (RES) or **7** (RES/+) if the vehicle speed is above 20 mph (30 km/h).

When the speed is stored, cruise control activation is confirmed by display of the cruising speed and, depending on the vehicle, the **10**

warning light  or  is displayed.



NB : if the speed previously stored is much higher than the current speed, the vehicle will accelerate more rapidly to reach this threshold.



When the cruise control is set to standby, pressing button **1** (SET/-) or **2** (SET/+) or **7** (RES/+) reactivates the cruise control function without taking into account the stored speed : it is the speed at which the vehicle is moving that is taken into account.

Switching off the function

The cruise control function is interrupted when:

- you press the button **9** or **4** until the OFF appears on the instrument panel. In this case, the speed is no longer stored ;

- you press the button **8** or **4** until warning light  or  appears on the instrument panel. In this case the speed limiter is selected and there is no stored speed.

The **10** warning light  or  disappears from the instrument panel to confirm that the function is disabled.



Putting the cruise control on standby or switching it off does not cause a rapid reduction in speed : you must brake by depressing the brake pedal.

STOP AND GO ADAPTIVE CRUISE CONTROL

Based on information from a camera, the Stop and Go adaptive cruise control function gives you the option of maintaining a selected speed, known as the cruising speed, while keeping a safe distance from the vehicle in front in the same lane.

Depending on the vehicle, when the "Road Sign Detection" function is activated, the system can adapt the speed of your vehicle according to the detected speed limit.

If the vehicle in front stops, the Stop and Go adaptive cruise control can brake your vehicle to a complete stop before setting off again.

The system controls acceleration and deceleration of your vehicle using the engine and braking system.

The system's maximum range is approximately 140 m. This may vary according to the road conditions (ground relief, weather conditions etc.).

The Stop and Go adaptive cruise control function can be activated from 0 to 99 mph (0 to 160 km/h) according to conditions on the road (traffic, weather etc.).

It is represented by the symbol



or



Note :

- the driver must observe the maximum speed limit and safe distances in the country where they are driving ;
- the adaptive cruise control can brake the vehicle up to a third of the braking capacity. Depending on the situation, the driver may need to brake harder.



The Stop and Go adaptive cruise control does not trigger an emergency stop and its braking capability is limited.



This function is an additional driving aid.

It can under no circumstances replace the

driver's responsibility to respect speed limits and safe distance or to be vigilant.

The driver must always be in control of the vehicle.

The driver must always adapt their speed according to the surroundings and traffic conditions. Stop and Go adaptive cruise control must only be used on a motorway (or multi-lane road with a central barrier). The cruise control must not be used in heavy traffic, on winding or slippery roads (black ice, aquaplaning, gravel) or during bad weather (fog, rain, side winds etc.). **There is a risk of accidents.**

STOP AND GO ADAPTIVE CRUISE CONTROL

Location of the camera 1

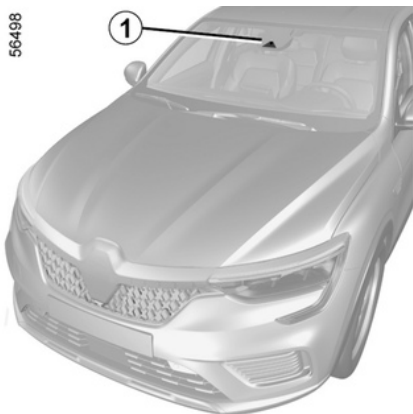

Make sure the windscreen is not obscured (by dirt, mud, snow, etc.).



The camera zones must be kept clean and free of any tampering in order to ensure the proper operation of the system.

Controls

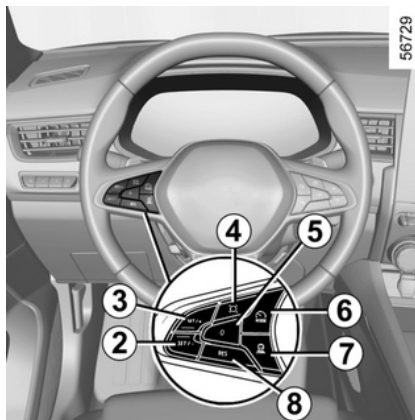

6 Switch for selecting/deselecting the driving aids, depending on the vehicle :

- Active driver assist;
- Stop and Go Adaptive cruise control;
- Speed limiter;
- Off.

7 Adjusting the following distance

8 Recall the stored cruising speed (RES)

2 Activates, decreases cruising speed or stores the current speed (SET/-)

3 Activates, increases cruising speed or stores the current speed (SET/+)

4 (depending on the vehicle) Adapts the speed setpoint to detected

speed limits 

5 Put the function on standby (with cruising speed stored) (0).



Depending on the vehicle, you can link the cruise control function to the "Road sign detection" function → **186** by pressing the button **4**.

STOP AND GO ADAPTIVE CRUISE CONTROL

Displays

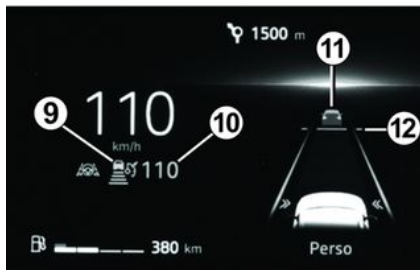

9 Stop and Go adaptive cruise control indicator light

10 Stored cruising speed

11 Vehicle in front



12 Stored safe distance



Important: you should keep your feet near the pedals at all times to prepare for any event.

Switching on

Press the button **5** as many times as necessary to select adaptive cruise control.

The indicator light **9**  or  appears in grey, and the message "Adaptive Cruise Ctl selected" appears on the instrument panel, accompanied by dashes to indicate that the cruise control function is selected and waiting to store a cruising speed.

This function cannot be activated when:

- the parking brake is applied ;
- the Park Assist function is already activated → **229**.

The message "Adaptive Cruise Ctl unavailable" is displayed on the instrument panel.

Activating cruise control

When the vehicle is stationary or moving at a steady speed, press switches **2** (SET/-) or **3** (SET/+) to activate the function and store the current speed. The minimum cruising speed is 19 mph (30 km/h).

The cruising speed **10** replaces the dashes and cruise control is confirmed by the appearance of the

cruising speed **10** and the indicator light **9**  in green.

If you attempt to activate the function at a speed over 99 mph (160 km/h), the message "Invalid Speed" appears and the function remains inactive.

Once a cruising speed is stored and the cruise control function is active, you may lift your foot off the accelerator pedal.

Note : if your vehicle speed is lower than about 19 mph (30 km/h), the function uses a default cruising speed of 19 mph (30 km/h). The vehicle will accelerate until it reaches the stored cruising speed.



Important : you should keep your feet near the pedals at all times to prepare for any event.

Activating cruise control with speed limit sign recognition

If the vehicle is equipped with the "Road Sign Detection" function, the system can manually adapt the speed of your vehicle according to the detected speed limit.

STOP AND GO ADAPTIVE CRUISE CONTROL

56740



When the new speed limit is detected, the system may propose the detected speed to the driver:

13 with the white square is displayed around the indicated speed to inform.

By pressing the button **4** , driver can adapt the vehicle speed to the detected speed.

13 with the green square is displayed around the indicated speed and the cruising speed **10** is set to the detected speed.

Safe distance control activation

As soon as cruise control is activated, the default safe distance **12** is displayed in green on the instrument panel. The default safe distance corresponds to approximately two seconds.

If the system detects a vehicle in your lane, an outline of a vehicle **11** appears above the distance gauge **12** on the instrument panel.

Your vehicle adapts its speed to that of the vehicle in front and applies the brakes if necessary (the brake lights come on) in order to maintain the distance displayed on the instrument panel.

Note : the size of the **11** outline varies according to the distance separating you from the vehicle in front. The larger the outline, the closer the vehicle in front.

Setting the cruising speed

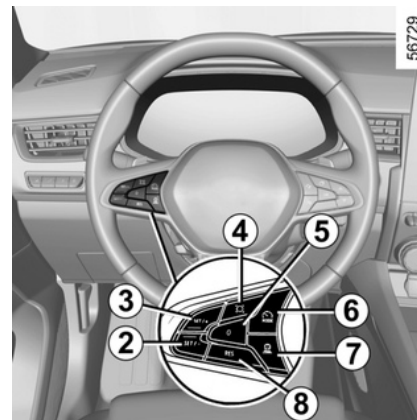

You can vary the speed by repeatedly pressing (for low variation) or pressing and holding (for high variation) switch **2** or **3** :

- use the "SET/-" switch **2** to reduce the speed ;
- use the "SET/+" switch **3** to increase the speed.

STOP AND GO ADAPTIVE CRUISE CONTROL

Adjusting the following distance



You can vary the safe distance from the vehicle in front at any time by pressing switch **5** repeatedly.

The horizontal distance gauge on the instrument panel indicates the various available safe distances :

- distance gauge **A** : long distance (corresponding to approximately 2.4 seconds) ;
- distance gauge **B** : intermediate distance 2 (corresponding to approximately 2 seconds) ;
- distance gauge **C** : intermediate distance 1 (corresponding to approximately 1.6 seconds) ;

- distance gauge **D** : short distance (corresponding to approximately 1.2 seconds).

The selected distance gauge appears in green on the instrument panel. The other gauges remain in grey.

Note : the distance must be set according to the traffic level, local regulation and weather conditions.



The safe distance is adjusted by default on the distance gauge **B**.

Exceeding the cruising speed

The cruising speed may be exceeded at any time by applying the accelerator pedal.

If it is exceeded, the cruising speed **10** appears in yellow.

The distance gauge flashes if the distance between your vehicle and the vehicle in front is less than the safe distance selected : the "safe distance control" function is no longer active.

Then, release the accelerator pedal : the cruise control and safe distance control will automatically resume

the speed and distance instructions that you had previously selected.

Overtaking manoeuvre

If you wish to overtake the vehicle in front, activating the indicator will temporarily cancel the safe distance control and enable an acceleration speed sufficient to complete overtaking.

Stop and start

If the vehicle in front slows down the system adapts its speed, to a complete stop if necessary (in the event of a traffic jam, etc). The vehicle stops a few metres from the vehicle in front. The Stop and Start function can put the engine on standby. → **131**
When the vehicle in front sets off again :

- If the stop does not exceed about three seconds the vehicle sets off automatically without any action by the driver ;
- if the stop exceeds about three seconds, you must apply the accelerator pedal or press button **B** (RES) in order for the vehicle to set off again. The message "Press RES or accelerate to restart Cruise Control" appears on the instrument panel to confirm.

STOP AND GO ADAPTIVE CRUISE CONTROL

If the vehicle is equipped with the "Road Sign Detection" function :

- If the stop does not exceed about thirty seconds, the vehicle sets off automatically without any action by the driver ;
- if the stop exceeds about thirty seconds, you must apply the accelerator pedal or a press button **8** (RES) in order for the vehicle to set off again. The message "Press RES or accelerate to restart Cruise Control" appears on the instrument panel to confirm.



the the driver should always be ready for sudden incidents while driving and remains responsible for controlling the vehicle: if the system detects a pedestrian in the area around the vehicle, the automatic restart will be inhibited until the next stop;

If the stop exceeds about three minutes, the electronic parking brake is automatically applied and the Stop and Go adaptive cruise control is deactivated. The  or  indica-

tor light goes out to confirm that the function is deactivated.

Putting the function on standby

You can set the function to standby when :

- you press switch **5** (0) ;
- you apply the brake pedal while the vehicle is moving.
- you switch the driving aids 'Active Driver Assist' to 'Adaptive Cruise Control' by pushing the button **6**

The function is deactivated by the system if :

- you put the gearbox in P, R or N ;
- you unbuckle the driver's seatbelt ;
- you open one of the opening elements ;
- you press the engine start/stop button ;
- the slope is too steep ;
- the vehicle speed is above 105 mph (170 km/h) ;
- certain driving aids and correction devices are triggered (active emergency braking, ABS, ESC, etc.).

In all circumstances, the standby is confirmed when the warning lights appear in grey and/or the message "Adaptive Cruise Ctl Disconnected" appears on the instrument panel.



Putting the Stop and Go adaptive cruise control on standby or switching it off does not cause a rapid reduction in speed : you must brake by applying the brake pedal if necessary.

Exit from standby

Based on the stored cruising speed

If a speed is stored, it can be recalled, once you are sure that the road conditions are suitable (traffic, road surface, weather conditions, etc.). Press switch **8** (RES) in the range of confirmed speeds.

When the stored speed is recalled, activation of the cruise control is confirmed by the illumination of the cruising speed in green.

Note : if the stored speed is higher than the current speed, the vehicle will accelerate to reach that speed.

Based on the current speed

When the cruise control is set to standby, pressing switch **2** (SET/-) or **3** (SET/+) reactivates the cruise control function without taking into account the stored speed : it is the

STOP AND GO ADAPTIVE CRUISE CONTROL

speed at which the vehicle is moving that is taken into account.

"Take control of the vehicle" warnings

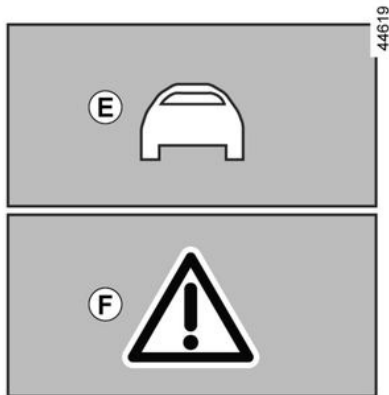

In some situations (e.g. coming upon a much slower vehicle, vehicle in front changing lanes quickly etc.), the system may not have time to react.

Depending on the situation, the system sounds a beep associated with:

– the orange alert **E** if the situation requires the driver's attention;
or



– the red alert **F** accompanied by the message "Brake", if the situation

requires the driver's immediate attention.



In all situations, react accordingly and perform the appropriate manoeuvres.

Switching off the function

The Stop and Go adaptive cruise control function is deactivated when you press switch **6**.

The warning light  or  disappears from the instrument panel to confirm that the function is no longer active.

Temporary unavailability

The green warning light  or  disappears to confirm that the function has been automatically deactivated.

Conditions in certain geographical areas may hinder the function, for example:

- arid zones, tunnels, long bridges or lightly used roads without road lines, without signs or trees nearby;
- a military or airport zone.

You must leave such areas in order for the function to work.

In all cases, if the message is not erased after the engine is restarted, please contact an authorised dealer.



The system controls acceleration and deceleration of your vehicle using

the engine and braking system.

The system activates the brakes in order to maintain the set speed, the system applies limited braking. In the event of a steep descent, for example in a mountainous area, you must select a lower gear to benefit from engine braking.

To reduce the load imposed on the braking system and to prevent the brakes from overheating, the adaptive cruise control function may be temporarily interrupted and the "Check adaptive cruise control" message appears. The message disappears when the function becomes available again. If the message remains, contact an approved dealer.

STOP AND GO ADAPTIVE CRUISE CONTROL

Operating faults

If an operating fault is detected on one or more components of the system, the Stop and Go adaptive cruise control function is interrupted.

The  warning light appears on the instrument panel along with, depending on the malfunction, one of the following messages:

- "Check Front camera";
- "Check camera/Radar";
- "Check vehicle".

Consult an approved dealer.

Limitations of system operation

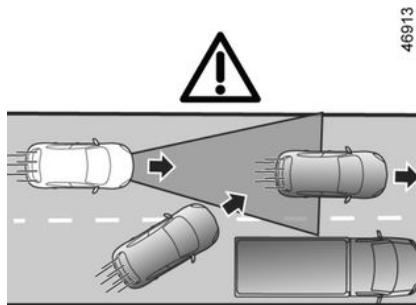

G

Vehicle detection

The system detects only vehicles (cars, trucks, motorbikes) that are moving in the same direction as your vehicle.

A vehicle turning into the same lane (e.g. **G**) will be taken into account by the system only once it enters the camera detection areas.

The system may trigger abrupt or delayed braking.

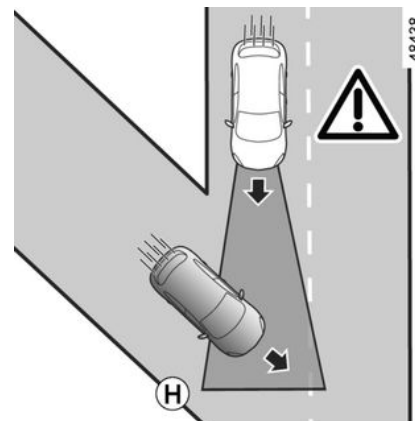

The system cannot detect:

- vehicles arriving at intersections: slip road (e.g. **H**) etc;



The Stop and Go adaptive cruise control function must only be used outside built-up areas, on wide roads with visible lines.

STOP AND GO ADAPTIVE CRUISE CONTROL

3

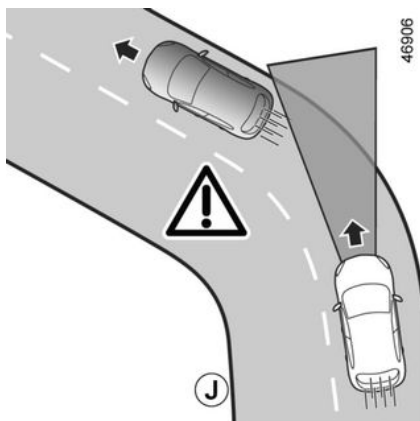

- vehicles driving on the wrong side of the road or reversing towards you.

Detection during cornering

When entering a corner or bend, the camera may temporarily not be able to detect the vehicle in front (e.g. J).

The system may trigger an acceleration.

When exiting a bend, the system's detection of the vehicle in front may be disrupted or delayed.

The system may trigger inappropriate or delayed braking.



Detection of vehicles in adjacent lanes

The system may detect vehicles driving on an adjacent lane when :

- you drive into a bend (e.g. K) ;
- you are driving on a road with narrow lanes ;
- the speed of the vehicle on the adjacent lane is slower and if one of these vehicles is located too close to the lane of the other.

The system may incorrectly trigger vehicle slowing or braking.

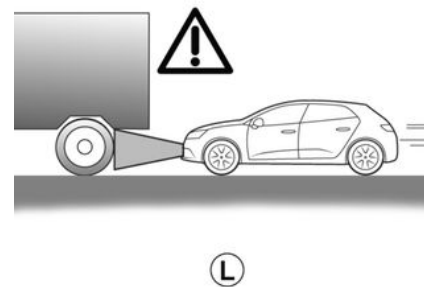

Vehicles hidden due to variations in ground relief

The system will not detect vehicles hidden due to variations in ground relief or those located outside of the camera detection areas when driving uphill or downhill.

Vehicles outside the camera detection areas.

The system will react late or not at all if the detected vehicles are outside the camera detection areas, particularly in the following cases :

STOP AND GO ADAPTIVE CRUISE CONTROL

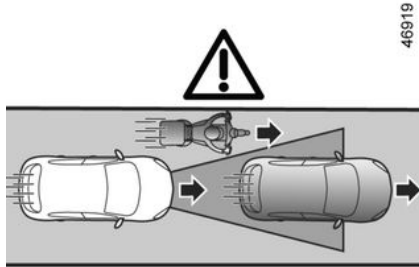

46919

(M)

- vehicles transporting long objects which exceed the line;
- the actual length of tall vehicles (e.g. **L**) outside the camera detection area (construction machine, agricultural equipment towing vehicle, etc.);
- vehicles insufficiently centred in the lane;
- narrow vehicles which are very close (e.g. **M**).

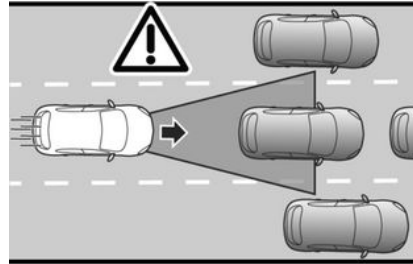

46931

(N)

Stationary and slow moving vehicles

When your speed is over approximately 31 mph (50 km/h), **the system does not detect** :

- stationary vehicles (e.g. **N**) ;
- very slow moving vehicles.

When your speed is less than approximately 31 mph (50 km/h), **the system may not react or may react very late** to :

- stationary vehicles (e.g. **N**) ;
- very slow moving vehicles ;

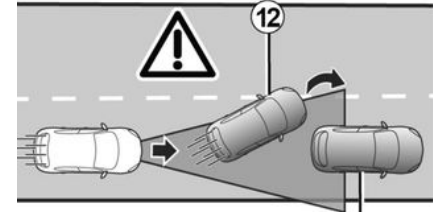

46932

(P)

(13)

- vehicles in front **12** which change lane, revealing a stationary vehicle **13** (e.g. **P**).

3

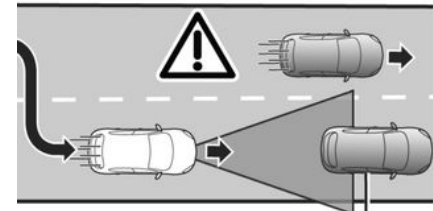

57120

(Q)

(14)

STOP AND GO ADAPTIVE CRUISE CONTROL

- when the vehicle is stationary **14**, when you change lane (e.g. **Q**).



Always be ready to take control of your vehicle when you come upon stationary or very slow moving vehicles (e.g. **N).**

The Stop and Go adaptive cruise control does not trigger an emergency stop and its braking capability is limited.

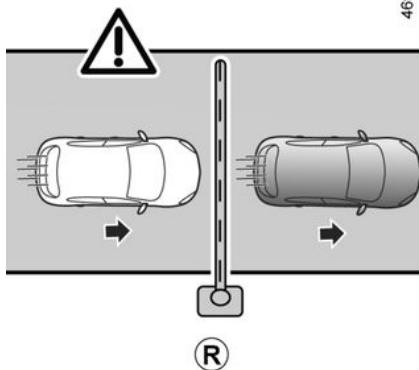

Non-detection of fixed obstacles and objects of a small size

The system cannot detect :

- pedestrians, bikes, scooters, etc. ;
- animals ;
- fixed obstacles (toll barriers, walls, etc.) (e.g. **R**).

These are not taken into account by the system. They do not trigger any alert or reaction by the system.

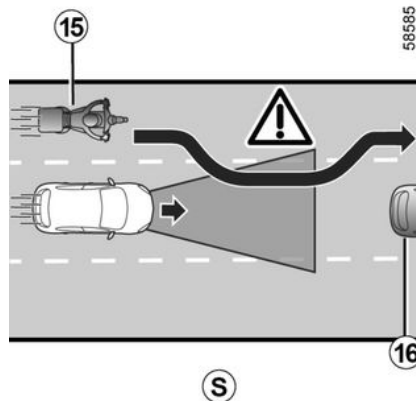

Detection of vehicles moving into lane at high speed

If your vehicle is overtaken by another vehicle driving at high speed **15** (motorcycle, car, etc.) and the vehicle is temporarily between you and the vehicle in front **16**, **the system may trigger undue acceleration, slowing or braking.**



This function is an additional driving aid. It can under no circumstances replace the

driver's responsibility to respect speed limits and safe distances or to be vigilant.

The driver must always be in control of the vehicle.

Apart from the speed limit signs and road map information from the mapping (vehicles fitted with the "Road sign detection" function and a subscription), other traffic information (traffic lights, pedestrian crossings, etc.) is not taken into account by the system. The driver must always adapt their speed to the surroundings and driving conditions, regardless of system indications.

The system should under no circumstances be taken to be an obstacle detector or an anti-collision system.

Use the adaptive cruise control Stop and Go outside built-up areas, on wide roads with visible lines.

STOP AND GO ADAPTIVE CRUISE CONTROL

System servicing/repairs

– In the event of an impact, the camera alignment may be changed and its operation may consequently be affected. Deactivate the system and consult an authorised dealer.

– Any work in the proximity of the camera (replacements, repairs, windscreen modifications, paintwork etc.) must be carried out by a qualified professional.

Only an authorised dealer is qualified to service the system.

Deactivating the function

You must deactivate the function if:

- the vehicle is being towed (breakdown recovery);
- the vehicle is towing a trailer or a caravan;
- the vehicle is being driven in a tunnel or close to a metallic structure;
- the vehicle arrives at a toll point, a roadwork area or on a narrow lane;

– the vehicle is driven on a very winding road (mountain road, etc.);

– the vehicle is being driven up or down a very steep slope;

– the visibility is poor (glaring sun, fog, etc.);

– the vehicle is being driven on a slippery road surface (rain, snow, gravel, etc.);

– the weather conditions are poor (rain, snow, side winds, etc.);

– the camera area has been damaged (e.g. interior or exterior windscreen area);

– the windscreen is cracked or distorted.

In the event of the system behaving abnormally, deactivate it and consult an authorised dealer.



In the event of system disturbance

Some conditions can disturb or damage the operation of the system, such as:

- the windscreen is obscured in the area of the camera (dirt, ice, snow, condensation, number plate etc.);
- a complex environment (tunnel etc.);
- poor weather conditions (snow, heavy rain, hail, black ice, etc.);
- poor visibility (night, fog etc.);
- poor contrast between the vehicle preceding it and the surrounding area (e.g. white vehicle in a snowy area etc.);
- being dazzled (glaring sun, lights of vehicles travelling in the opposite direction etc.);
- narrow, winding or undulating road (tight bends etc.);
- a slower vehicle with a significant difference in speed;

STOP AND GO ADAPTIVE CRUISE CONTROL

3

– use of mats not adapted to the vehicle. On the driver's side, only use mats suitable for the vehicle, attached with the pre-fitted components, and check the fitting regularly. Do not lay one mat on top of another.

There is a risk of wedging the pedals.

In these cases, the system may wrongly intervene.

Risk of unwanted braking or acceleration.

Many unforeseen situations may affect the system operation. Certain objects or vehicles that can appear in the camera detection zone may be interpreted by the system incorrectly, possibly leading to inappropriate acceleration or braking.

You should always be attentive to sudden events that might occur while you are driving. Always keep your vehicle under control by keeping your feet near the pedals, so that you are ready to act in any event.

PARKING AIDS

Parking distance control

Operating principle

Ultrasonic sensors, indicated by arrows **1**, are fitted in the bumpers to measure the distance between the vehicle and an obstacle.

This measurement is indicated by beeps which become more frequent the closer you come to the obstacle, until they become a continuous beep when the vehicle is approximately 20 to 30 centimetres from the obstacle.

Depending on the configuration of the vehicle, the system detects obstacles to the front, the rear and the sides of the vehicle.

The parking distance control system is only activated when the vehicle is driven at a speed below approximately 6 mph (10 km/h).

The function does not take into account towing or carrying systems that are not recognised by the system.

Location of the ultrasonic sensors **1**

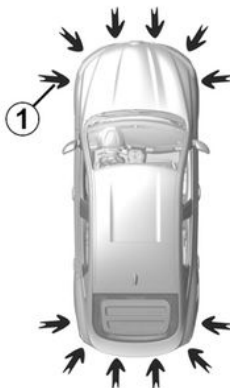

52118

Ensure that the ultrasonic sensors indicated by arrows **1** are not obscured (by dirt, mud, snow, a badly fitted/attached number plate), impacted, modified (including paintwork) or obstructed by any accessory fitted to the rear and/ or, depending on the vehicle, to the front or sides of your vehicle.



This function is an additional aid that indicates the distance between the vehicle and an obstacle whilst reversing, using sound signals.

Under no circumstances should it replace the driver's care or responsibility whilst reversing.

The driver should always be ready for sudden incidents while driving: always ensure that there are no small, narrow moving obstacles (such as a child, animal, pushchair, bicycle, stone, post, etc.) in the blind spot when manoeuvring.

PARKING AIDS

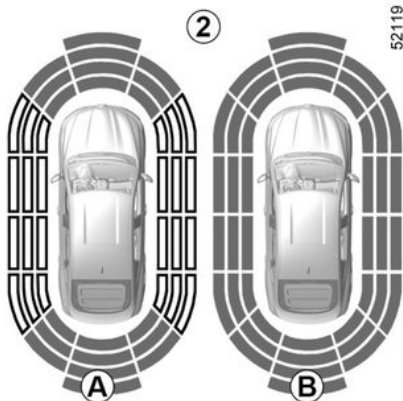

Note: the display **2** shows the vehicle surroundings and emits beeps.

It is necessary to travel a few metres before the side detection is activated.

If all areas have a grey background, the whole area around the vehicle is being monitored:

- **A**: analysis of the vehicle surroundings in progress;
- **B**: analysis of the vehicle surroundings carried out.

Operation

Most objects located less near the front, rear and sides of the vehicle are detected.



An impact to the underside of the vehicle while manoeuvring (e.g. striking a post, raised kerb or other street furniture) may result in damage to the vehicle (e.g. deformation of an axle).

To avoid any risk of accident, have your vehicle checked by an approved dealer.

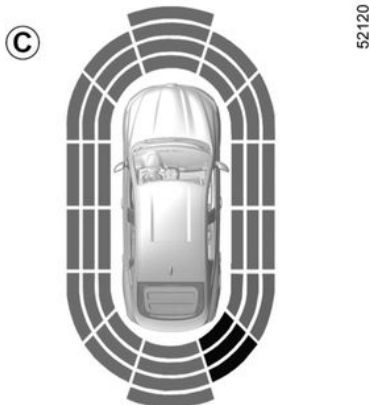

Depending on the distance of the obstacle, the frequency of the beep will be higher while approaching it, and will become a continuous beep

around 30 cm away for obstacles to the sides, and around 30 cm for obstacles to the front or rear. The green, orange (or yellow depending on the vehicle) and red zones will be displayed on the **C** display.

Note: in the event of a change in trajectory during a manoeuvre, the risk of collision with an obstacle may be signalled late.

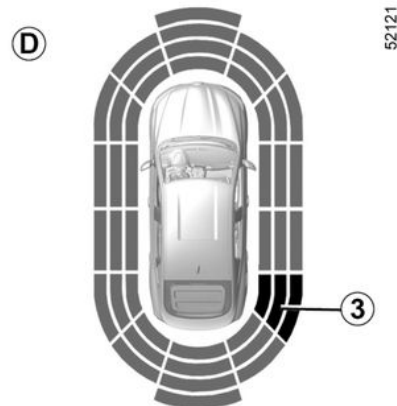

Detection of obstacles to the side

Depending on the direction of the wheels, the system determines the trajectory of the vehicle and notifies the driver of any risk or otherwise of a collision with an obstacle **3** to the side of the vehicle.

PARKING AIDS



An impact to the underside of the vehicle while manoeuvring (e.g. striking a post, raised kerb or other street furniture) may result in damage to the vehicle (e.g. deformation of an axle).

To avoid any risk of accident, have your vehicle checked by an approved Dealer.

If a side obstacle is detected :

- the beeps become faster and then sound continuously as the obstacle gets nearer. Green, orange and red zones will be displayed on the display **D** ;
- if there is no risk of collision, no beep will sound when approaching the obstacle. Green, orange and red zones will be displayed interspersed on the display **D**.

Note : in the event of a change in trajectory during a manoeuvre, the risk of collision with an obstacle may be signalled late.

Activation/deactivation

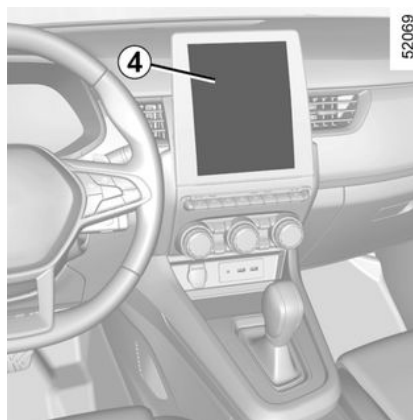

Vehicles fitted with a multimedia screen **4**

To activate or deactivate the various zones covered by the ultrasonic detectors, please refer to the multimedia instructions.

Select "ON" or "OFF".



depending on the vehicle, the rear detection zone cannot be deactivated.

Vehicles not fitted with a multimedia screen

With the vehicle stopped, press the **5** switch as many times as required to reach the "Vehicle" tab ;

press the **6** or **7** control repeatedly to reach the "Settings" menu. Press the switch **8** OK ;

press the **6** or **7** control repeatedly to reach the "PARKING ASSIST" menu. Press the switch **8** OK.



depending on the vehicle, the rear detection zone cannot be deactivated.

Adjustment

Vehicles fitted with a multimedia screen **4**

Depending on the vehicle, with the engine running, some settings can be adjusted from the multimedia screen **4**. Please refer to the multimedia instructions for further information.

Parking distance control audio volume

Adjust the volume of the parking distance control by pressing + or -.

PARKING AIDS

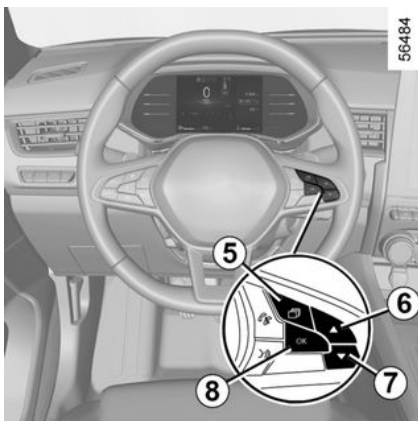

3

System sound

Enables the system sound to be chosen.

Deactivating the system sound

Activate or deactivate the parking distance control sound.

Note : if you deactivate the sound, you will no longer be notified with beeps when approaching an obstacle.

 When the vehicle is travelling at a speed below approximately 6 mph (10 km/h), some noises (motorcycle, lorry, pneumatic drill etc.) may trigger the beeping sound of the parking distance control.

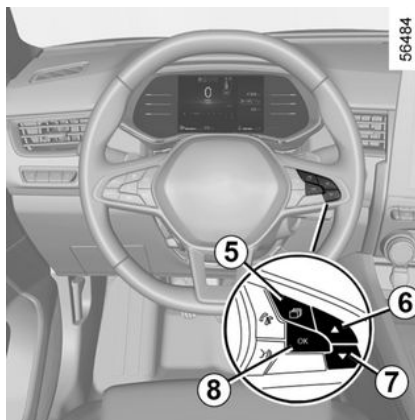

Vehicles not fitted with a multimedia screen

- With the vehicle stopped, press the **5** switch as many times as required to reach the "Vehicle" tab ;
- press the **6** or **7** control repeatedly to reach the "Settings" menu. Press the switch **8** OK ;

- press the **6** or **7** control repeatedly to reach the "PARKING ASSIST" menu. Press the switch **8** OK ;
- select "Bip volume" to adjust the volume of Park Assist using control **6** or **7**.

Deactivating the parking distance control manually

You must disable the function if :

- if towing, carrying or trailer equipment that is unrecognised by the system is present in front of the ultrasonic detectors ;
- in the event of damage to the ultrasonic sensors.

Automatic deactivation of the parking distance control

The system deactivates :

- when the vehicle speed is above approximately 6 mph (10 km/h) ;
- depending on the model, when the vehicle is stationary for more than approximately 5 seconds and an obstacle is detected (such as when in a traffic jam, etc.) ;
- when you are in position N or P ;
- when an operating fault is detected.

Note : if the vehicle is fitted with a towbar recognised by the system,

PARKING AIDS

only the rear Park Assist function is deactivated.

Operating faults

When the system detects an operating fault, a beep sounds for approximately three seconds each time reverse gear is selected and the message "Check parking sensors" appears on the instrument panel. Consult an approved dealer.



An impact to the underside of the vehicle while manoeuvring (e.g. striking a post, raised kerb or other street furniture) may result in damage to the vehicle (e.g. deformation of an axle).

To avoid any risk of accident, have your vehicle checked by an approved dealer.



System servicing/repairs

– In the event of an impact, the alignment of the sensors may be altered and their operation may consequently be affected. Deactivate the function and consult an authorised dealer.

– Any work in the area where the sensors are located (repairs, replacements, etc.) must be carried out by a qualified professional.

Only an authorised dealer is qualified to service the system.

System disturbance

Some conditions can disrupt or damage the operation of the system, for example :

- poor weather conditions (rain, snow, hail, black ice, etc.);
- some types of noise (motorcycle, lorry, pneumatic drill etc.);
- fitting an unsuitable towing ball or hook.

Risk of false alarms or absence of warnings

In the event of the system behaving abnormally, deactivate it and consult an authorised dealer.

PARKING AIDS

Limitation of the system operation

- The area around the sensors must be kept clean and free of any modifications in order to ensure the proper operation of the system.
- Small objects moving close to the vehicle (motorcycles, bicycles, pedestrians, etc.) may not be recognised by the system.
- The system may not detect objects that are too close to the vehicle.
- The system may not provide a warning when the other vehicles or objects are travelling at a significantly different speed.
- During a change in trajectory, during a manoeuvre, the system may report obstacles with a delay.
- When the vehicle is towing a trailer, the rear Park Assist system must be deactivated.

Deactivating the function

You must disable the function if:

- the area around the sensors has been damaged (rear bumper);
- the vehicle is equipped with a towing device that is not recognised by the system (ball, hook, adapter, etc.).

Reversing camera

Operation



When the vehicle is reversing, the camera **1** on the luggage compartment lid transmits a view of the area surrounding the rear of the vehicle to the multimedia display **2** accom-

panied by two guiding lines **3** and **4** (fixed and mobile).

This system uses several guidelines for its operation (mobile for trajectory and fixed for distance). When the red zone is reached, use the bumper image to stop accurately.

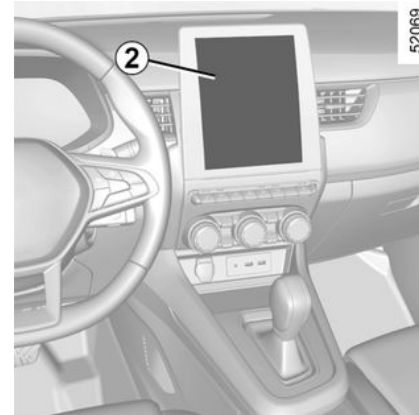

Fixed guideline **3**

The fixed clearance gauge comprises coloured markers **A**, **B** and **C** indicating the distance behind the vehicle:

- **A** (red) approximately 30 centimeters from the vehicle;
- **B** (yellow) approximately 70 centimeters from the vehicle;
- **C** (green) approximately 150 centimeters from the vehicle.

PARKING AIDS

This gauge remains fixed and indicates the vehicle trajectory if the wheels are in line with the vehicle.

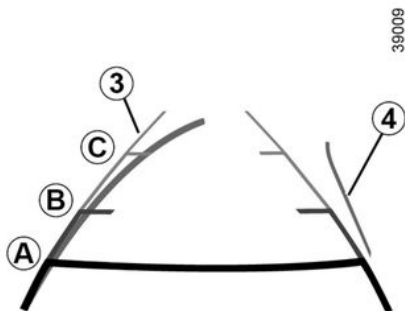

Dynamic guideline 4:

This is shown in blue on the multimedia screen **2**. It indicates the vehicle trajectory according to the position of the steering wheel.

Special feature

Make sure that the camera is not obscured (by dirt, mud, snow, condensation etc.).

Settings

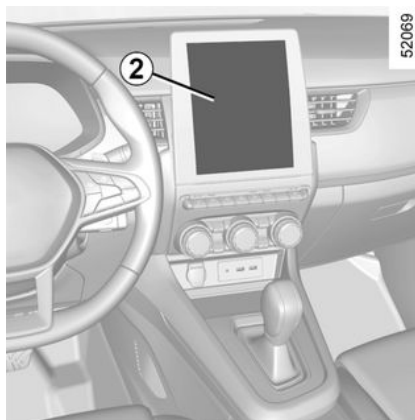

While the engine is running, from the multimedia screen **2** you can add or remove the guides and adjust the camera image settings (brightness, contrast etc.). Please refer to the multimedia instructions for further information.

Operating faults

When reverse gear is engaged, if the system detects an operating fault, a black screen is displayed temporarily on the multimedia screen **2**.

This may be caused by a fault affecting the camera or screen (clearness, fixed image, delayed communication etc.).

If the temporary display of the black screen persists, please consult an approved dealer.



This function is an additional aid. It cannot, therefore, under any circumstances replace

the vigilance or the responsibility of the driver.

The driver should always be ready for sudden incidents while driving : always ensure that there are no small, narrow moving obstacles (such as a child, animal, pushchair, bicycle, stone, post, etc.) in the blind spot when manoeuvring.

PARKING AIDS



The screen shows a reverse mirror image.

The frames are a representation projected on a flat surface. This information is to not be taken into account when superimposed on a vertical object or an object on the ground. Objects which appear on the edge of the screen may be deformed.

In very bright light (snow, vehicle in sunshine, etc.), the camera vision may be adversely affected.

If the boot is open or poorly closed, the message "WARNING: Boot Open" appears and the reversing image could be disappeared.

Difference between the estimated distance and actual distance

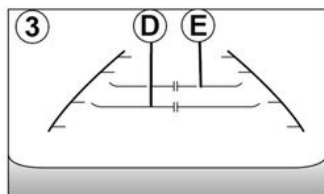
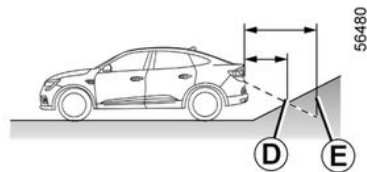

Reversing towards a steep uphill slope

The fixed guidelines **3** show the distances as closer than they actually are.

The objects shown on the screen are actually further away on the slope.

For example, if the screen displays an object at **D**, the actual distance of the object is at **E**.

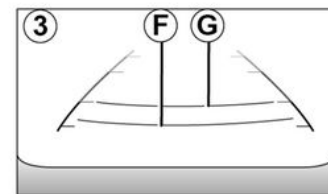
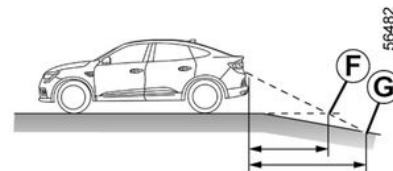

Reversing towards a steep downhill slope

The fixed guidelines **3** show the distances as further than they actually are.

Therefore, the objects shown on the screen are actually closer on the slope.

For example, if the screen displays an object at **G**, the actual distance of the object is at **F**.

PARKING AIDS

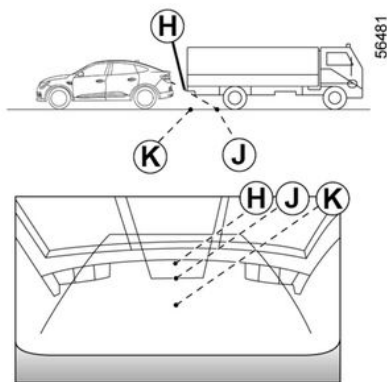

Reversing towards a protruding object

Position **H** seems further than position **J** on the screen. However, position **H** is at the same distance as position **K**.

The trajectory indicated by the fixed and mobile guidelines do not take into account the height of the object. So there is a risk that the vehicle may collide with the object when reversing towards position **K**.

Assisted parking

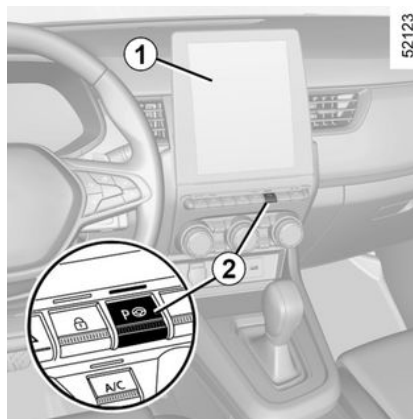

Using ultrasonic detectors as indicated by the **3** arrows installed in the vehicle bumpers, this function helps to find accessible parking spaces and assists in the parking manoeuvre.

Remove your hands from the steering wheel, you only control :

- the accelerator pedal ;
- the brake pedal ;
- the gear lever.

You can retake control at any time by operating the steering wheel.

Switching on

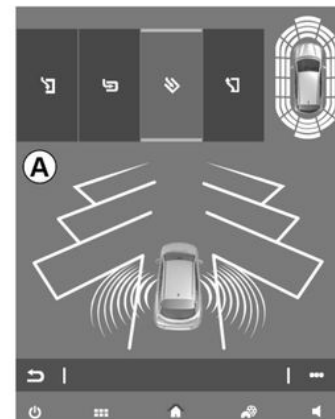

While the engine is running, vehicle stationary or driving at less than approximately 19 mph (30 km/h) :

- press switch **2**. The warning light integrated into the **2** switch lights up and the **A** display appears on the multimedia screen **7** ;
- set the direction indicator to the side of the vehicle where you want to park.

PARKING AIDS

Special features

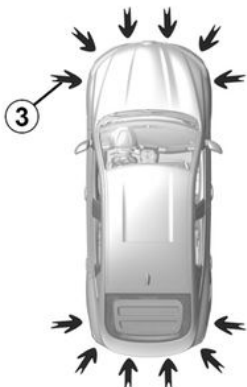

Ensure that the ultrasonic sensors indicated by arrows **3** are not obscured (by dirt, mud, snow, etc.).

Choice of manoeuvre

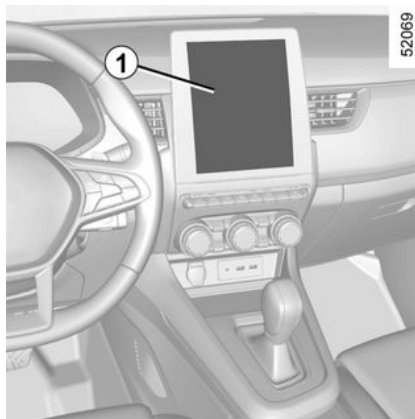

The system can perform four types of manoeuvres :

- parallel parking ;
- perpendicular parking ;
- angle parking ;
- moving out of a parallel parking space.

From the **1** multimedia screen, select the manoeuvre to carry out.

Note : when starting the vehicle, or after having successfully completed parallel parking using the system, the default manoeuvre proposed by the system is assistance in exiting a parallel parking space. In other cases, the default manoeuvre can be set from the multimedia screen **1**.

Please refer to the multimedia instructions for further information.

 The system start up is accompanied by activation of the parking distance control and, on those vehicles equipped, the reversing camera to help the driver visualise the manoeuvre. → **221**, → **226**

Operation

Parking

As long as the vehicle speed is less than 19 mph (30 km/h), the system searches for available parking spaces on the side of the vehicle chosen by the driver.

Note : if parking spaces are available on the other side of the vehicle, set the direction indicator to the other direction to enable the system to search for spaces.

Once a space has been found, it is displayed on the multimedia screen, indicated by a small letter "P". Drive slowly, with the direction indicators activated on the side where the space is available, until the "Stop" message is displayed and a beep sounds.

PARKING AIDS

The space is then indicated on the multimedia screen by a capital letter "P".

- Stop the vehicle;
- select reverse gear.

The indicator light  lights up on the instrument panel and a beep sounds.

- Release the steering wheel ;
- follow the instructions shown on the multifunction screen **1**.

Your speed should not exceed around 4 mph (7 km/h).

Once the warning light  on the instrument panel goes off and a beep sounds, the manoeuvre has been completed.



This function is an additional driving aid. Therefore, it can under no circumstances replace the driver's vigilance and responsibility during manoeuvres (the driver must always be ready to brake).

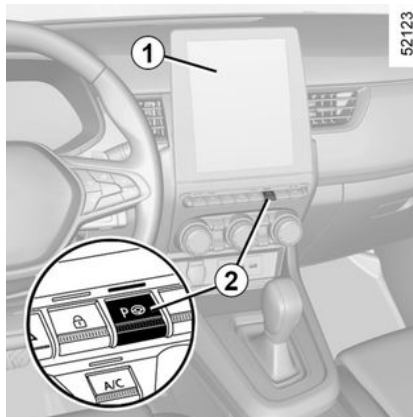

Exiting a parallel parking space

- Briefly press the **2** switch ;
- Select the "Exit parallel parking space" mode ;
- set direction indicator to the side on which you wish the vehicle to exit ;
- press and hold the **2**. switch (around two seconds).

The indicator light  lights up on the instrument panel and a beep sounds.

- Release the steering wheel ;
- carry out manoeuvres at the front and rear by following the instructions shown on the multimedia

screen **1** and using the parking distance control system alerts.

Your speed should not exceed around 4 mph (7 km/h).

Once the vehicle is in a position to

exit the parking space, the  warning light disappears from the instrument panel and a sound signal and message appear on the multimedia screen **1** to confirm that the manoeuvre is complete.



When manoeuvring, the steering wheel may turn quickly : do not put your hands inside, and make sure that nothing is caught inside.

PARKING AIDS

Suspending/Resuming the manoeuvre

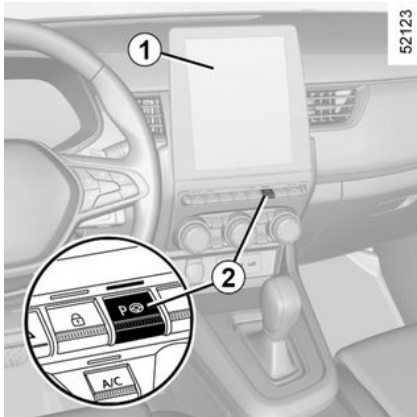

The manoeuvre is suspended in the following circumstances:

- you take control of the wheel;
- the vehicle is stationary for too long;
- an obstacle in the direction of movement prevents the manoeuvre from being completed;
- the engine stops;
- a door or the luggage compartment is opened.

The warning light on the **2** switch turns off and the **P** warning light disappears from the instrument panel and a sound signal confirms

that the manoeuvre has been suspended. The reason for suspending the manoeuvre will be displayed on the multimedia screen **1**.

Make sure:

- you have released the steering wheel;
- and
- that all doors and the boot are closed;
- and
- that no obstacles are in the way of the direction of movement;
- and
- that the engine is started.

If the warning light on the **2** switch flashes, this indicates that the system is once again available to resume the manoeuvre.

To resume the manoeuvre, press and hold the **2** switch. The **2** switch

warning light appears and **P** is displayed on the instrument panel.

Follow the instructions shown on the multimedia screen **1**.

Cancelling the manoeuvre

The manoeuvre is cancelled in the following cases:

- the vehicle speed has exceeded 4 mph (7 km/h);
- by pressing switch **2**;
- you have performed more than ten forwards/backwards movements in one manoeuvre;
- the parking distance control sensors are dirty or blocked;
- the vehicle wheels have skidded;
- the manoeuvre has been suspended for too long.

The **2** switch warning light and the **P** warning light disappear from the instrument panel and a sound signal confirms that the manoeuvre has been cancelled. The reason for cancelling the manoeuvre will be displayed on the multimedia screen **1**.

PARKING AIDS

Warning



This function is an additional driving aid. This function is not under any circumstances intended to replace the due care and attention of the driver, who should at all times be in control of the vehicle. Make sure that the manoeuvre complies with the applicable traffic regulations in your location.

The driver should always be ready for sudden incidents while driving : always ensure that there are no small, narrow moving obstacles (such as a child, animal, pushchair, bicycle, stone, post, towing equipment, etc.) in the blind spot when manoeuvring.

System servicing/repairs

- In the event of an impact, the alignment of the sensors may be changed and their operation may consequently be affected. Deactivate the function and consult an authorised dealer.
- Any work in the area where the sensors are located (repairs, replacements, exterior trim modifications, etc.) must be carried out by a qualified professional.

Only an authorised dealer is qualified to service the system.

In the event of system disturbance

Certain conditions may disrupt or impair operation of the system, such as poor weather conditions (snow, hail, ice, etc.).

In the event of the system behaving abnormally, deactivate it and consult an authorised dealer.

Risk of erroneous false alarms.

Limitations of the system operation

- The system cannot detect objects located in the sensor blind spots.
- Always visually check that the parking space proposed by the system is still available and contains no obstacles.
- The system should not be used when towing a trailer or when there is a towing or load carrying system on the vehicle or on surrounding vehicles.

PARKING AIDS

360° camera

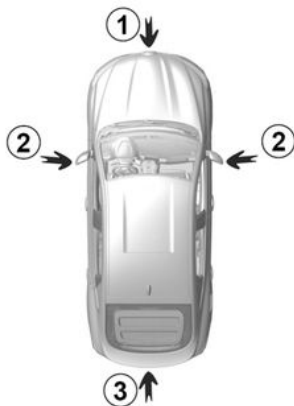

56464

Using information from cameras **1**, **2**, and **3** located in the front bumper, door mirrors and on the tailgate, as well as ultrasonic detectors **4** located in the vehicle bumpers, the feature assists with difficult manoeuvres (e.g. parking) by displaying the vehicle surroundings.



This function is an additional aid. It cannot, therefore, under any circumstances replace the vigilance or the responsibility of the driver.

The driver should always be ready for sudden incidents while driving: always ensure that there are no small, narrow moving obstacles (such as a child, animal, pushchair, bicycle, stone, post, etc.) in the blind spot when manoeuvring.

Operation

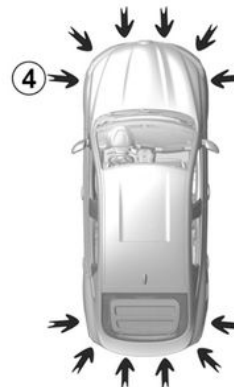

56463

The cameras transmit four separate views to the multimedia screen **5**.

They enable you to view the vehicle surroundings:

- front view: using camera **1**;
- rear view: using camera **3**;
- bird's eye view: using cameras **1**, **2** and **3**;

PARKING AIDS

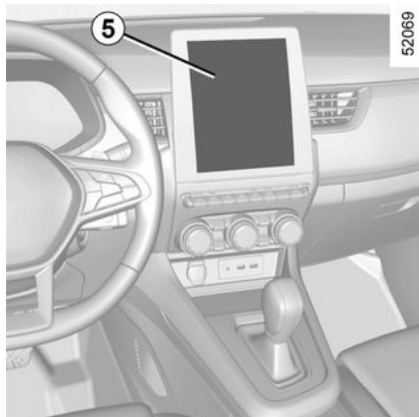

– front side view (depending on the vehicle) : using camera **2** (passenger side).

The ultrasonic detectors detect obstacles at the front, rear and (depending on the vehicle) side of the vehicle.

Note : make sure that the cameras are not obscured (by dirt, mud, snow etc.).

Front view 1

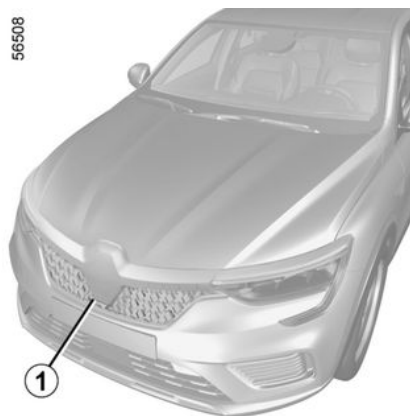

The view of the front camera is displayed on the multimedia screen **5**.

Fixed clearance gauge **6**

The “front” view transmitted to the multimedia screen **5** is displayed with one or two guidelines **6** and **7**.

This system is initially used with the aid of several gauges (mobile for trajectory and fixed for distance).

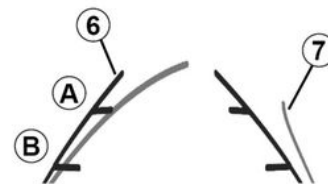

The fixed clearance gauge comprises coloured markers **A** and **B** indicating the distance behind the vehicle:

- **B** (yellow) approximately 70 centimetres from the vehicle ;
- **A** (green) approximately 150 centimetres from the vehicle.

Dynamic gauge **7** (depending on the vehicle)

This is shown in blue on the multimedia screen **5**. It indicates the vehicle trajectory according to the position of the steering wheel in the front view.

PARKING AIDS

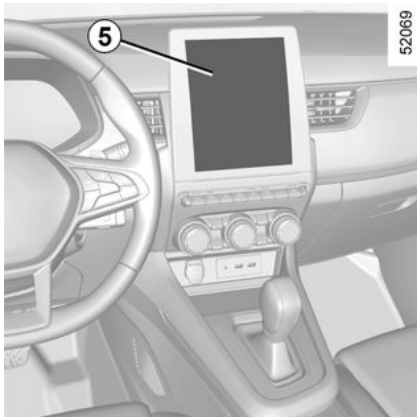

i The driver should be aware about the blind zone which exists approximately up to 40cm from the end of front bumper on "Front view" mode of 360° camera. In order to avoid any risk of accident, a driver should be cautious of visual and auditory warning supported from the parking assist system. Parking assist system displays the distance is shown in the 360° view with colored indicator lines for each sensor that registers an obstacle.

Rear view 3

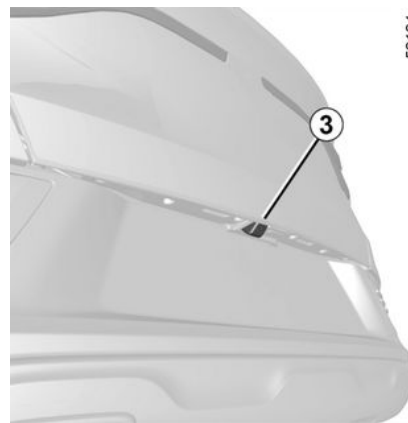

The view of the rear camera is displayed on the multimedia screen **5**.

Fixed clearance gauge **6**

The "rear" view transmitted to the multimedia screen **5** is displayed with one or two guidelines **6** and **7**.

This system is initially used with the aid of several gauges (mobile for trajectory and fixed for distance).

PARKING AIDS

35987

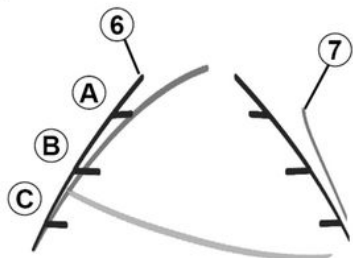

The fixed clearance gauge comprises coloured markers **A**, **B** and **C** indicating the distance behind the vehicle:

- **C** (red) approximately 30 centimetres from the vehicle (rear view only);
- **B** (yellow) approximately 70 centimetres from the vehicle;
- **A** (green) approximately 150 centimetres from the vehicle.

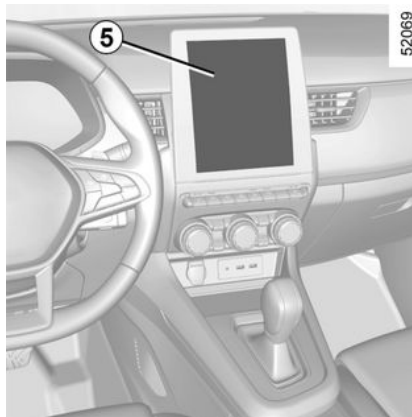

Dynamic gauge 7 (depending on the vehicle)

This is shown in blue on the multimedia screen 5. It indicates the vehicle trajectory according to the position of the steering wheel in the rear view.

 The 5 multimedia screen shows a reverse image of the rear view 3 as in a rear view mirror.



In front view or rear view: when manoeuvring on a slope, objects shown on the multimedia screen may be closer or further away than they seem.

Take this into account in order to correctly assess the distance before any manoeuvre.



The front, rear and side view guidelines are a representation projected onto flat ground; this information must not be taken into account when superimposed on a vertical object or an object on the ground.

Objects displayed on the edge of the multimedia screen may appear distorted.

In very bright light (snow, vehicle in sunshine etc.), the camera vision may be adversely affected.

PARKING AIDS



In the combined representation from the cameras :

- raised objects (pavement, vehicle, etc.) may appear distorted in bird's eye view ;
- any objects on top of the vehicle are not displayed.

Bird's eye view

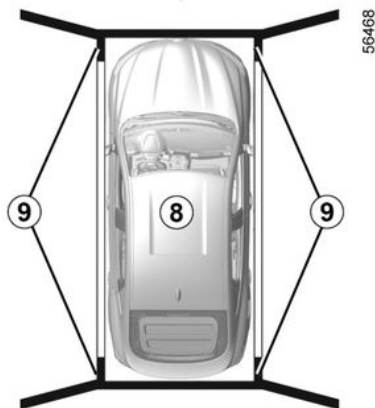

The bird's eye view is a combined representation from cameras **1**, **2** and **3**.

It displays a view of the top of the vehicle and its surroundings.

This can be used to confirm a view of the vehicle position in relation to its immediate surroundings (front, rear and side).

The **8** view indicates the vehicle position. **9** areas not covered by the cameras are indicated in black.



In "bird's eye view" mode, the objects displayed on the multimedia screen are actually further away than they seem.

Take this into account in order to correctly assess the distance before any manoeuvre.

Front side view on passenger side 2



(depending on the vehicle)

The camera, fitted in the door mirror, transmits a side view to the multimedia screen **5**.

Depending on the vehicle, you can use the multimedia screen to change the bird's eye view to the front side view. Please refer to the multimedia instructions for further information.

PARKING AIDS

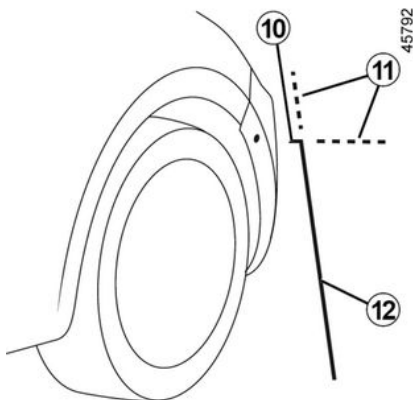

The "Front side view on passenger side" is transmitted to the multimedia screen with guidelines to measure the distances.

Fixed guidelines 10, 11 and 12

Fixed guideline **10** shows the front section of the vehicle.

Fixed guideline **12** shows the vehicle width including door mirrors.

Fixed guidelines **11** are shown in red and dotted. These are extensions of fixed guidelines **10** and **12**.

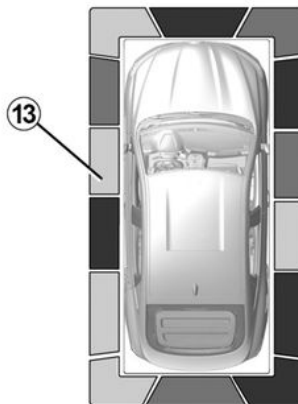

Depending on the vehicle, you can use the multimedia screen to change the bird's eye view to the front side view. Please refer to the multimedia instructions for further information.

Obstacle detection

While the system is activated, if the "Park Assist" function detects one or more obstacles around the vehicle, the **13** indicator lines display:

- on the bird's eye view;
- on the front side view on the passenger side (depending on the vehicle).

In addition to the sound alert, these indicator lines show the proximity of obstacles via different colours:

- Green : obstacle between 50 and 70 cm ;
- Yellow : obstacle between 30 and 50 cm ;
- Red : obstacle within 30 cm.

These indicator lines also show the location where the obstacles are detected, as indicated by their positions in relation to the "vehicle" symbol.

For more information → **221**

Activation/deactivation

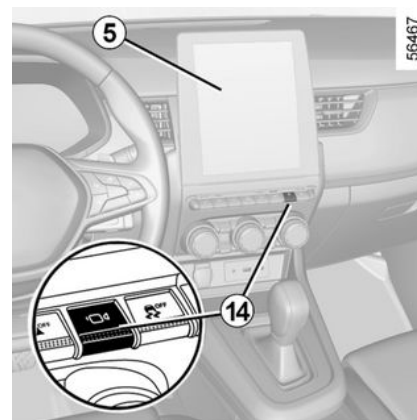

Automatic mode

PARKING AIDS

With the vehicle stationary and the engine running, automatic mode is activated when the reverse gear is engaged. The rear view and the bird's eye view appear on the **5** multimedia screen.

When the reverse gear is quickly shifted to forward gear, the rear view and bird's eye view are replaced by the front view and bird's eye view on the **5** multimedia screen.

Automatic mode is disabled :

- when the gear lever is in neutral (manual gearbox) or in position N or P (automatic gearbox) for approximately three seconds ;
- when the vehicle speed moving forward exceeds 6 mph (10 km/h).

Manual mode

To activate manual mode, with the vehicle stopped and the engine running, press the **14** switch : the front view and bird's eye view appear on the multimedia screen.

Manual mode is disabled :

- when the vehicle speed moving forward reaches 6 mph (10 km/h) ;
- when the gear lever has not been used for three minutes ;
- when you press the **14** button.



- Do not use this function while the door mirrors are in folded position.
- Ensure that the luggage compartment door is properly closed before using the function.
- Do not place any objects on or in front of the cameras.

Difference between the estimated distance and actual distance

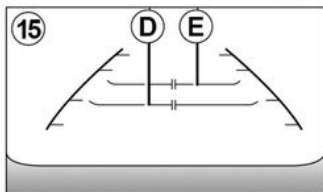
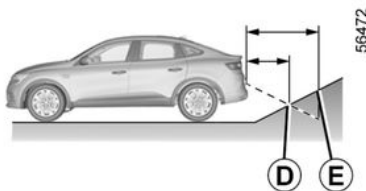

Driving or reversing towards a steep uphill slope

The fixed guidelines **15** show the distances as closer than they actually are.

The objects shown on the screen are actually further away on the slope.

For example, if the screen displays an object at **D**, the actual distance of the object is at **E**.

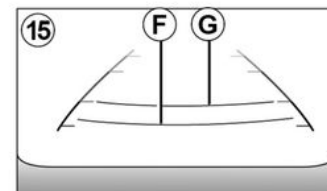
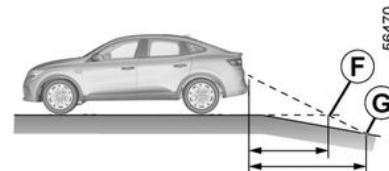

Driving or reversing towards a steep downhill slope

The fixed guidelines **15** show the distances as further than they actually are.

Therefore, the objects shown on the screen are actually closer on the slope.

PARKING AIDS

For example, if the screen displays an object at **G**, the actual distance of the object is at **F**.

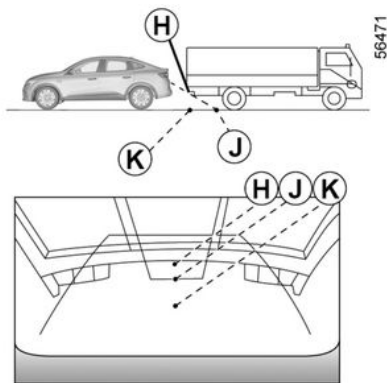

Driving or reversing towards a protruding object

Position **H** seems further than position **J** on the screen. However, position **H** is at the same distance as position **K**.

The trajectory indicated by the fixed and mobile guidelines do not take into account the height of the object. So there is a risk that the vehicle may collide with the object when reversing towards position **K**.

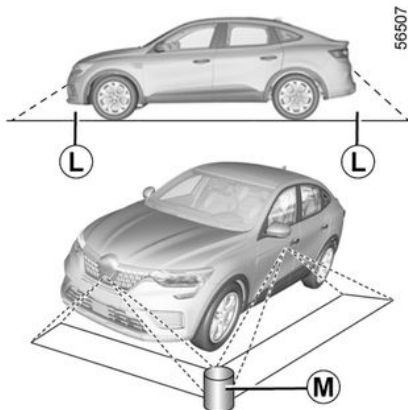

Limits of the feature

The system is unable to display objects located in certain areas.

In the front or rear view mode, the system cannot be used to view an object in area **L**.

In bird's eye view mode, the system cannot be used to view a large object in area **M** (near the edge of the displayed area).

Adjusting the display

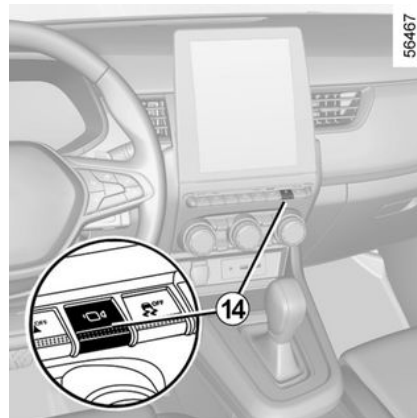

With the ignition on, press the **14** switch or move the selection lever to position R (on an automatic gearbox) or to reverse gear (on a manual gearbox) in order to use the feature.

The function displays different views on the screen according to the gear lever position.

Depending on the vehicle, you can select the "bird's eye view" or "front side view on the passenger side".

PARKING AIDS



For safety reasons, carry out any adjustments when the vehicle is not being driven.

3

If the gear lever is in position R (on an automatic gearbox) or in reverse (on a manual gearbox), the following views are available :

- screen split between the rear view/bird's eye view ;

or

- screen split between the rear view/front side view (depending on the vehicle).

When shifting from reverse gear to position P (on an automatic gearbox) or to neutral position (on a manual gearbox), the following views are available :

- screen split between the rear view/bird's eye view ;

or

- screen split between the rear view/front side view (depending on the vehicle).

When shifting from reverse gear to position D (on an automatic gearbox) or into a gear (on a manual

gearbox), the following views are available :

- screen split between the front view/bird's eye view ;

or

- screen split between the front view/front side view (depending on the vehicle).

Adjusting the camera settings

The following settings can be modified :

- brightness ;
- colours ;
- contrast.

Please refer to the multimedia instructions for further information.

Note : for safety reasons, the views are not displayed in the settings menu while the vehicle is moving.

Parking exit warning

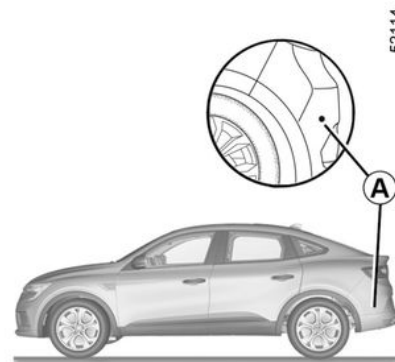

52114

Using information from the radars installed on each side of the rear bumper (area **A**), the system notifies the driver when another vehicle appears in the detection zone **B**.

The function is activated if :

- reverse gear is engaged ;
- the vehicle is stationary or driving at a low speed.

PARKING AIDS

47550

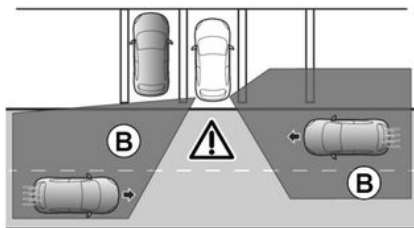

i The system's detection capability depends on the vehicle's surroundings (static objects etc.) and the condition of the bumper etc.



This function is an additional driving aid. This function is not under any circumstances intended to replace the due care and attention of the driver, who should at all times be in control of the vehicle.

47549

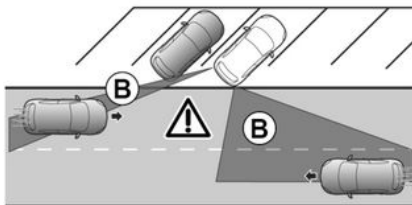

Activation/deactivation from the multimedia screen 1

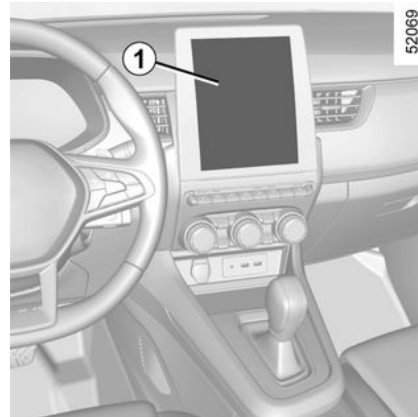

52069

3

To activate or deactivate the function, refer to the multimedia instructions.

Select "ON" or "OFF".

PARKING AIDS

Operation

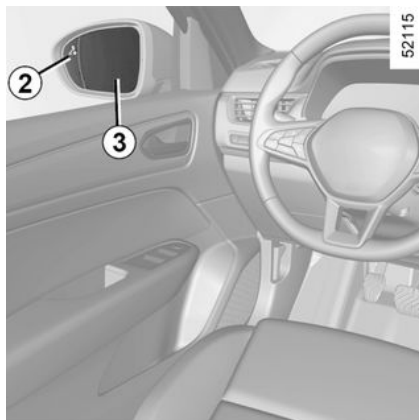

The function warns when a vehicle is in area **B** and approaching your vehicle.

The indicator **2** is displayed on the door mirror **3** on both side on which a vehicle has been detected.

Note : clean the rear view mirrors **3** regularly so that the indicators **2** can be seen.

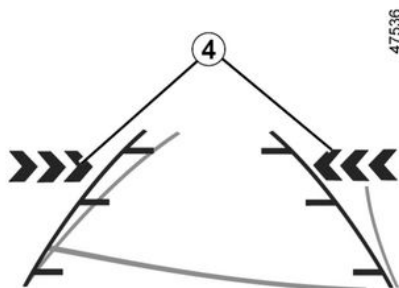

The indicators **4** on the multimedia screen show you on which side the approaching vehicle has been detected.

Note : clean the camera regularly so that it is not obscured.

Indicators **2** and **4** are accompanied by an audible signal when your vehicle is reversing.

Operating faults

If the system detects a fault, the message "Check Side radars" is displayed on the instrument panel. Consult an approved dealer.



Due to the presence of sensors behind the bumper, it is advisable to entrust any operation on the bumper (repair, replacement, paintwork, etc.) to a qualified professional.

PARKING AIDS



Limitation of the system operation

– The radar area should be kept clean and free of any modifications in order to ensure the proper operation of the system.

– Small objects (motorcycles, bicycles, pedestrians etc.) moving towards to the vehicle may not be recognised by the system.

Deactivating the function

You must disable the function if:

- the radar area **A** has been damaged (rear bumper);
- the vehicle is fitted with a towbar that is not recognised by the system.



This function is an additional driving aid. This function is not under any circumstances intended to replace the due care and attention of the driver, who should at all times be in control of the vehicle.

The system should under no circumstances be taken to be an obstacle detector or an anti-collision system.

System servicing/repairs

– In the event of an impact, the position of the radars may be changed, affecting the function. Deactivate the function and consult an authorised dealer.

– Any work in the area where the radars are located (repair, replacement, bodywork etc.) must be carried out by a qualified professional.

Only an authorised dealer is qualified to service the system.

System disturbance

Some conditions can disrupt or damage the operation of the system, for example:

- a complex environment (underground car park, steel structures etc.);
- poor weather conditions (snow, heavy rain, hail, black ice etc.).

Limitations of the system operation

- The system cannot detect objects located in the sensor blind spots.
- Always visually check that the parking space proposed by the system is still available and contains no obstacles.
- The system should not be used when towing a trailer or when there is a towing or load carrying system on the vehicle or on surrounding vehicles.

Risk of false alarms or absence of warnings

In the event of the system behaving abnormally, deactivate it and consult an authorised dealer.

EMERGENCY CALL

If the vehicle is equipped, the emergency call function can be used to call the emergency services (without charge) automatically or manually in the event of an accident or illness, reducing the time it takes for the emergency services to arrive.

Note : the emergency call operates :

- in countries covered by the associated telematics emergency services and infrastructure compatible with the system ;
- depending on the network coverage in the geographical region where the vehicle is being driven.

If you use the emergency call function to report an accident which you have witnessed, this implies stopping where traffic conditions allow in order for the emergency services to locate your vehicle and therefore the location of the reported accident.

In all cases, comply with local legislation.



Use the emergency call only in the event of an emergency you are involved in, if you witness an accident or if you feel ill.

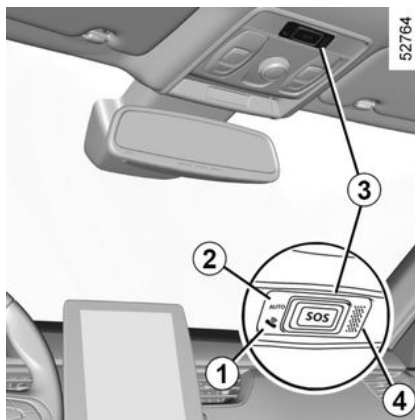

1. System operation warning light :

- green : operational (network available) ;
- off : non-operational (network unavailable) ;
- red : operating fault ;
- green flashing : call in progress.

2. Automatic mode warning light ;

3. SOS button ;

4. Microphone ;

5. Speaker.

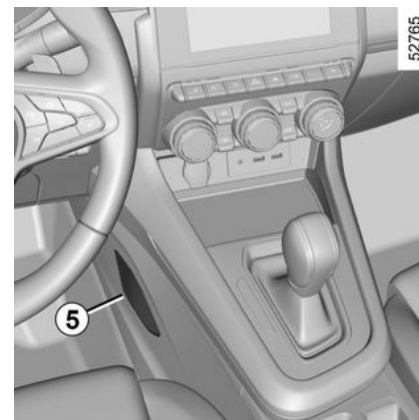

A call is always made as follows :

- the call is set up with the emergency services ;
- send data related to the incident (vehicle identification plate, local time of the call, last positions, direction of the vehicle) ;
- voice communication with the emergency services ;
- if necessary, emergency assistance is called.

Emergency call has two modes :

- automatic mode ;
- Manual mode.

Automatic mode

If the automatic mode **2** warning light appears in green this confirms

EMERGENCY CALL

that the automatic system is activated.

The emergency call starts automatically in the event of an accident that has required the activation of the protective equipment (seat belt pretensioners, airbag etc.).



In the event of an accident, if the location and traffic conditions permit, stay close to the vehicle in order to be able answer the call centre quickly if necessary.

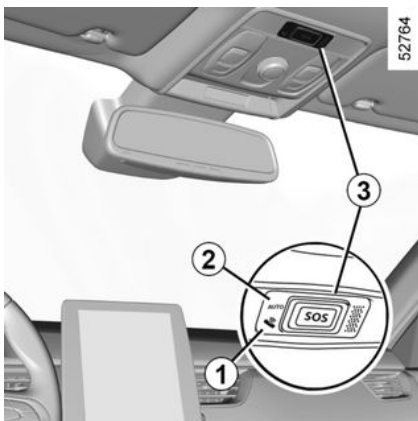

Manual mode

The emergency call is carried out by pressing and holding the **3** button for at least three seconds.

In the event of unintended operation, it is possible to cancel the call by pressing the **3** button for around two seconds, before the call is connected to the call centre.



Operating faults

In some cases, the emergency call may not work (e.g. low battery).

When the system detects an operating fault, the **1** warning light turns red for over 30 minutes; consult an Approved Dealer as soon as possible.



The system operates with a dedicated battery. The battery service life is approximately four years (the **1** warning light lights up in red to warn you when approaching expiry).

Consult an approved dealer



To guarantee your safety and the proper operation of the system, any operation carried out on the battery (removal, disconnection, etc.) must be carried out by a qualified specialist.

Risk of serious burns or electric shocks.

You must respect the replacement intervals (without exceeding them) as stated in the maintenance document.

The battery is a specific type. Please ensure it is replaced with the same type.

Call an approved Dealer.

EMERGENCY CALL



Without the emergency call feature, the system is not trackable and will not be under constant surveillance. Data is automatically and constantly erased, and the system stores only the last three positions of the vehicle.

Data is only sent in the event of an emergency call. Data sent to the call centre is treated according to the personal data protection laws applicable in the country where you are located. The system stores activity history data for 13 hours only. The vehicle owner has the right of access to their data. They can request that the data be corrected, deleted or locked.

MULTI-SENSE

The MULTI-SENSE system enables a choice between three driving modes that can be used to control, depending on the vehicle: driving, ambient lighting, comfort and engine sound:

- the Eco and Sport modes are pre-configured and can be partially customised (ambient lighting, etc.);
- the My Sense mode is customisable.

The drive modes affect the:

- power-assisted steering;
- the response of the engine and gearbox.

They also affect the:

- the lighting in the passenger compartment and of the instrument panel;
- the information on the instrument panel;
- depending on the vehicle, the engine sound.



Engine settings are specific to each of the driving modes and cannot be customised.

Eco mode

Eco mode focuses on energy saving. The steering is smooth, engine and gearbox management enable fuel consumption to be lowered. Air conditioning and heating are managed so that they are used only when necessary. ➔ 151

Sport mode

This mode enables an increased responsiveness from the engine and the gearbox. The steering is firmer.

My Sense mode

Using standard default vehicle settings, this mode can be used to manually configure driving, ambient lighting, comfort and engine sound (depending on the vehicle).



After the engine is switched off, the vehicle will always restart in My Sense mode.



In any mode, you can change the colour of the ambient lighting as well as the format of the information displayed on the instrument panel and multimedia screen. You can also reset to the default settings.

Accessing the menu

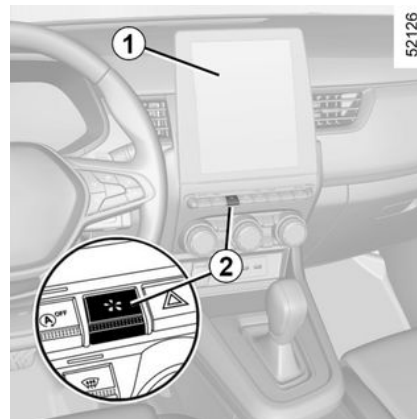

You can access MULTI-SENSE, depending on the vehicle:

- from the multimedia screen **1**;
- using the **2** switch.

MULTI-SENSE

Please refer to the multimedia instructions for further information.

4

AIR VENTS, HEATING AND AIR CONDITIONING

Air vents: air outlets

Air outlets

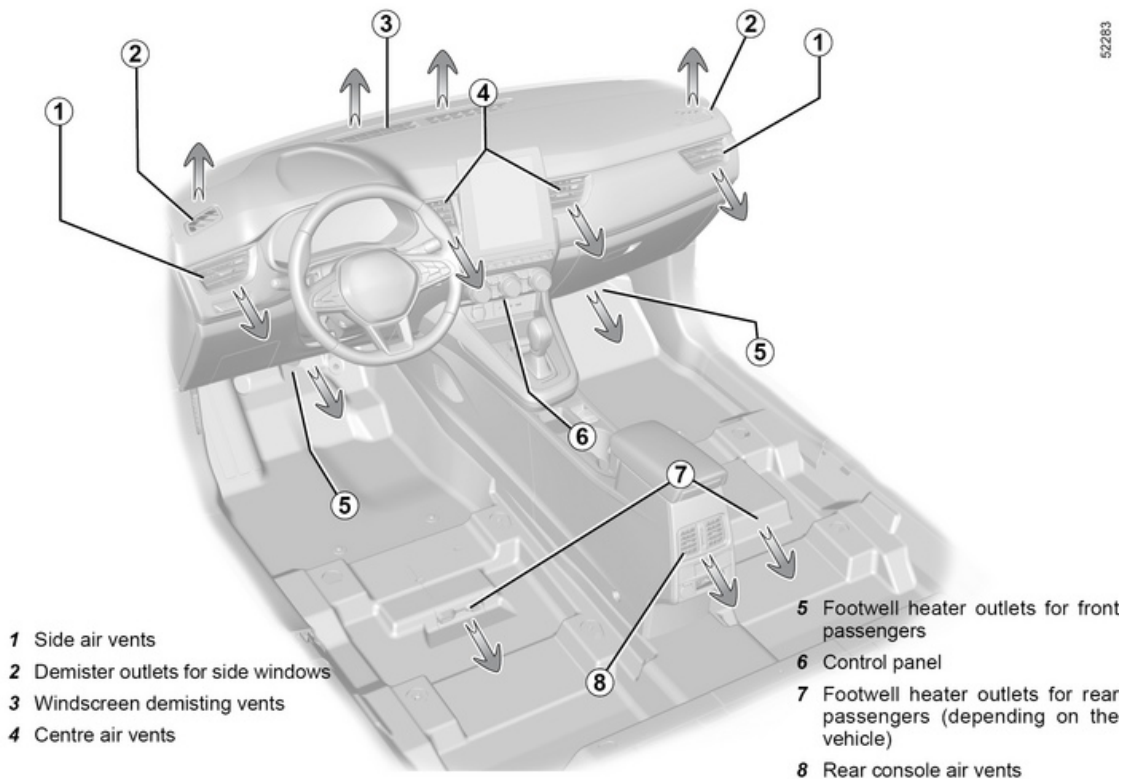

52283

AIR VENTS, HEATING AND AIR CONDITIONING

Central 4, side 1 and rear air vents 8

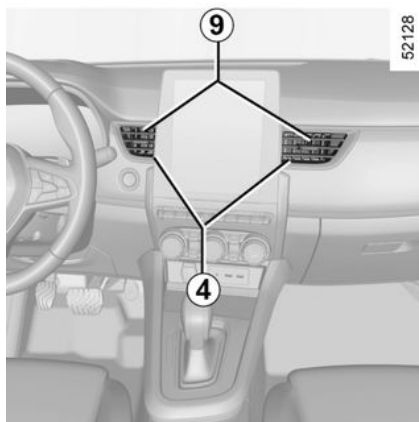

Air flow

To close : move the cursor 9 towards the outside of the vehicle beyond the resistance point.

To open : move the cursor 9 towards the inside of the vehicle.

Direction

Move the cursor 9 to the desired position.

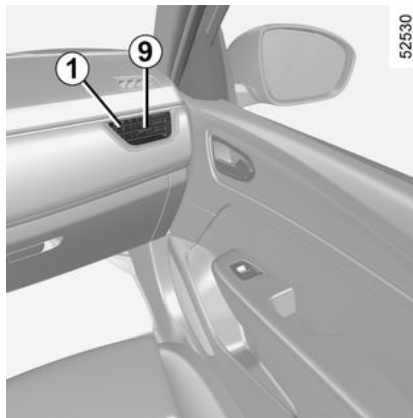

 Do not attach any objects to the air vents (e.g. telephone mounting).

Risk of damage.

Rear seats

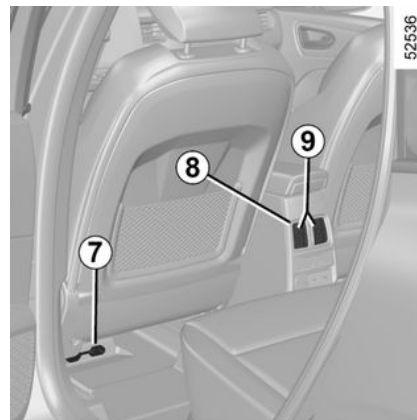

(depending on vehicle)

Passenger footwell heater outlets 8.



Do not add anything to the vehicle's ventilation circuit (for example, to remove bad odours).

There is a risk of damage or of fire.

AIR VENTS, HEATING AND AIR CONDITIONING

Manual air conditioning, heating system

The controls

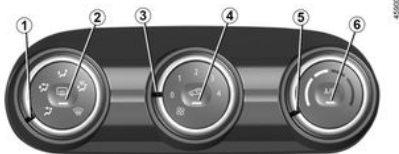

(depending on vehicle)

1. Distribution of air in the passenger compartment.
2. De-icing/demisting of the rear screen and, depending on the vehicle, the rear view mirrors.
3. Adjusting the ventilation fan speed.
4. Air recirculation.
5. Adjusting the air temperature.
6. Air conditioning.

Switching air conditioning on or off

The air conditioning is switched on (indicator light on) or off (indicator light off) using button **6**.

Activation is not possible if the **3** control is set to "0".

The air conditioning system is used for :

- lowering the temperature inside the passenger compartment ;
- eliminating condensation more quickly.

Distribution of air in the passenger compartment

There are five air distribution options. Turn control **1** to choose the distribution option.



The air flow is directed to the windscreen and the front side window demisting vents.



The air flow is distributed between front side window demisting vents, the windscreen demisting vents and the footwells.



The air flow is directed mainly towards the footwells.



The air flow is directed towards the dashboard air vents, the front footwells and, depending on the vehicle, the second row footwells.



The air flow is mainly directed to the dashboard air vents.

Switching the air recirculation on



Press the **4** button : the integrated indicator light comes on. Under these conditions, air is taken from the passenger compartment and is recirculated, with no air being taken from outside the vehicle.



If the air conditioning is not activated ("A/C" light on the **6** switch off), prolonged use of recirculated air may cause mist to form on the side windows and windscreen as well as other problems due to the presence of non-recirculated air in the passenger compartment. We therefore advise you to return to normal mode (external air) as soon as the air recirculation function is no longer required, by pressing button **4** again.

AIR VENTS, HEATING AND AIR CONDITIONING

Air recirculation is for :

- isolating the vehicle from the external atmosphere (driving in polluted areas, etc.);
- lowering the passenger compartment temperature as quickly as possible.

Adjusting the ventilation speed



Move control **3**. The further the control is positioned to the right, the greater the amount of air blown into the passenger compartment. If you want to shut off the flow of air, set the **3** control to "0".

The system is deactivated : the ventilation speed is zero (vehicle stationary). You can, however, still feel a slight flow of air when the vehicle is moving.



Use of the  position on the **1** control leads automatically to the air flowing out in order to prevent the risk of misting on the windscreen.

Adjusting the air temperature

Turn control **5** to obtain the desired temperature. The further towards the red the slide is, the higher the temperature will be.

When the air conditioning system is used for long periods, it may begin to feel cold. To increase the temperature, turn control **5** to the right.

Rear screen de-icing/demisting

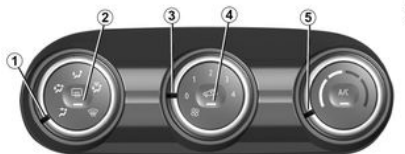

With the engine running, press button **2**. The operating tell-tale comes on.

This function permits rapid demisting/de-icing of the rear screen and

de-icing of the door mirrors (on equipped vehicles).

To exit this function, press button **2** again. Warning light goes out.

Demisting automatically stops.

Rapid demisting

Turn controls **1**, **3** and **5** to positions



- demisting ;
- blower at speed 3 or 4 ;
- maximum temperature.

Press the **4** button to disable the air recirculation (light off) and press the **2** button to activate de-icing of the rear screen (light on).



When the air conditioning system is turned off, the air recirculation is automatically activated according to conditions like vehicle speed to make the air more comfortable. Pressing the **4** button will disable this function.

AIR VENTS, HEATING AND AIR CONDITIONING

Automatic climate control

The controls



(depending on the vehicle)

1. Adjusting the ventilation fan speed.
2. "Clear View" function.
3. Adjusting the air temperature.
4. Automatic mode.
5. Air conditioning control.
6. Distribution of air in the passenger compartment.
7. Air recirculation.
8. De-icing/demisting of the rear screen and, depending on the vehicle, the rear view mirrors.

Automatic mode

The automatic climate control system guarantees comfort in the passenger compartment and good visibility (except in the event of extreme conditions), while optimising con-

sumption. The system controls the ventilation speed, air distribution, air recirculation, and starting and stopping the air conditioning and air temperature.

AUTO : allows the selected comfort level to be best attained, depending on the exterior conditions. Press button **4**.

Adjusting the ventilation speed.

In automatic mode, the system uses the most suitable amount of air to reach and maintain the desired comfort level.

You can still adjust the ventilation speed by turning control **1** to increase or reduce the ventilation speed.

Adjusting the air temperature

Turn control **3** to obtain the desired temperature.

Turning the control to the right increases the temperature.

 Any action on a button other than the AUTO button triggers deactivation of automatic mode.

Clear View function

Press the **2** button : the integrated indicator light comes on.

This function quickly demists and deices the windscreen, the rear screen, the front side windows, and the door mirrors (depending on the vehicle). It automatically activates the air conditioning and rear screen de-icing functions.

Press button **8** to stop the heated rear screen operating, and the integrated indicator goes out.

To exit this function, press button **2** or **4**.

 Some buttons have an operating tell-tale which indicates the operating status.

Adjusting the distribution of air in the passenger compartment



AIR VENTS, HEATING AND AIR CONDITIONING

Turn control **6**. The integrated warning light in the button comes on.



All the air is then directed to the windscreen and front side window demisting vents.



The air flow is distributed between front side window demisting vents, the windscreen demisting vents and the footwells.



The air flow is directed towards the dashboard air vents, the front footwells and, depending on the vehicle, the second row footwells.



The air flow is mainly directed to the dashboard air vents.



The air flow is directed mainly towards the footwells.

Rear screen de-icing/demisting



Press the **8** button : the integrated indicator light comes on. This function enables rapid demisting or de-icing of the rear screen and de-icing of the rear view mirrors (on equipped vehicles).

To exit this function, press button **8** again. Demisting automatically stops.

Switching air conditioning on or off

In automatic mode, the system switches the air conditioning system on or off, depending on the climate conditions.

Press the button **5** to force the air conditioning to stop. The integrated warning light will go out.

Air recirculation (isolation of the passenger compartment)



This function is managed automatically (operation is confirmed by a warning light on button **7**), but you can also activate it manually.



The demisting/de-icing will still take priority over the air recirculation.

Manual use

Press the **7** button : the integrated indicator light comes on.

Prolonged use of this position may lead to odours, caused by non-renewal of air, and the formation of condensation on the windows.

To avoid this, air recirculation is disabled automatically after a certain time.

We therefore advise you to return to automatic mode as soon as air recirculation is no longer needed, by pressing button **7**.

Stopping the system

Turn the control **1** to "OFF" to stop the system. To start it, turn the control **1** again, then adjust the fan speed or press the button **4**.



Fuel consumption increases when the air conditioning is being used (switch it off when it is not required).

AIR VENTS, HEATING AND AIR CONDITIONING



When the air conditioning system is turned off, the air recirculation is automatically activated according to conditions like vehicle speed to make the air more comfortable. Pressing the **7** button will disable this function.

Air conditioning: information and advice on use

Advice on use

In some situations (air conditioning off, air recirculation activated, ventilation speed at zero or low etc.), you may notice that condensation starts to form on the windows and windscreen.

If there is condensation, use the **"Clear View"** function to remove it, then use the air conditioning in automatic mode to stop it forming again.



Vehicles equipped with mode ECO

Once activated, ECO mode may reduce air conditioning performance. → 151.



Do not add anything to the vehicle's ventilation circuit (for example, to remove bad

odours).

There is a risk of damage or of fire.

Fuel consumption

You will normally notice an increase in fuel consumption (especially in town) when the air conditioning is operating.

For vehicles fitted with air conditioning with no automatic mode, switch off the system when it is not required.

Advice for reducing consumption and helping to preserve the environment

Drive with the air vents open and the windows closed. If the vehicle has been parked in the sun, open the doors for a few moments to let the hot air escape before starting the engine.

Maintenance

Refer to the Maintenance Document for your vehicle for the inspection frequency.



Use the air conditioning system regularly, even in cold weather, running it at least once a month for approximately 5 minutes.

Operating faults

As a general rule, contact your approved dealer in the event of an operating fault.

– Reduction in de-icing, demisting or air conditioning performance.

This may be caused by the passenger compartment filter cartridge becoming clogged.

– No cold air is being produced.

Check that the controls are set correctly and that the fuses are sound. Otherwise, switch off the system.

Special cases of hybrid versions

The vehicle's air conditioning system is used to cool the traction battery.

AIR VENTS, HEATING AND AIR CONDITIONING

A prolonged drop in air conditioning efficiency may lead to premature deterioration of the traction battery.

Presence of water under the vehicle

After prolonged use of the air conditioning system, it is normal for water to be present under the vehicle. This is caused by condensation.



Do not open the refrigerant fluid circuit. The fluid may damage eyes or skin.

The refrigerant fluid circuit (of which some components are hermetically sealed) may contain fluorinated greenhouse gases.

Refrigerant fluid R-134a

The refrigerant fluid circuit (of which some components are hermetically sealed) may contain fluorinated greenhouse gases.

Depending on the vehicle, you will find the following information on label **A** affixed inside the engine compartment.

The presence and location of the information on label **A** depends on the vehicle.



Do not open the refrigerant circuit. The fluid may damage eyes or skin.



Before carrying out any action in the engine compartment, you must switch off the ignition. → 128



Type of refrigerant fluid



(XXX) Type of oil in the air conditioning circuit



Inflammable product



Consult the vehicle user manual



Maintenance

x.xxx kg	Quantity of refrigerant fluid present in the vehicle.
GWP xxxxx	Global Warming Potential (CO ₂ equivalent).
CO ₂ eq x.xx t	Quantity in weight and in CO ₂ equivalent.



59951

AIR VENTS, HEATING AND AIR CONDITIONING

59945



Refrigerant fluid R-1234yf

The refrigerant fluid circuit (of which some components are hermetically sealed) may contain fluorinated greenhouse gases.

Depending on the vehicle, you will find the following information on label **B** affixed inside the engine compartment.

The presence and location of the information on label **B** depends on the vehicle.

Engine TCe 260 refrigerant fluid type : R-1234yf.



Be careful not to use refrigerants that do not meet the specifications. **Risk of damage.**

The refrigerant is under high pressure and flammable depending on the specification. **Risk of injury.**

Consult an approved dealer.



Type of refrigerant fluid



(XXX) Type of oil in the air conditioning circuit



Inflammable product



Consult the vehicle user manual



Maintenance

x.xxx kg	(1) Quantity of refrigerant fluid present in the vehicle.
GWP xxxxx	(2) Global Warming Potential (CO2 equivalent).
CO2 eq x.xx t	(3) Quantity in weight and in CO2 equivalent.

Additional information

Depending on label and depending on the type of refrigerant:

Refrigerant fluid R-1234yf

- **(1)** 0,500 kg/0.620 kg
- **(2)** GPWP 4
- **(3)** 0.002t

59944



AIR VENTS, HEATING AND AIR CONDITIONING

4



589952

MULTIMEDIA EQUIPMENT

Multimedia system A or B

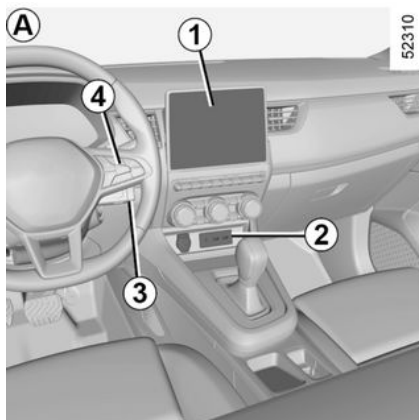

The location and operation of equipment may vary according to the vehicle.

1. Multimedia screen ;
2. Multimedia sockets ;
3. Steering column controls ;
4. Steering wheel controls ;



Please refer to the multimedia instructions for further information.

Multimedia sockets 2

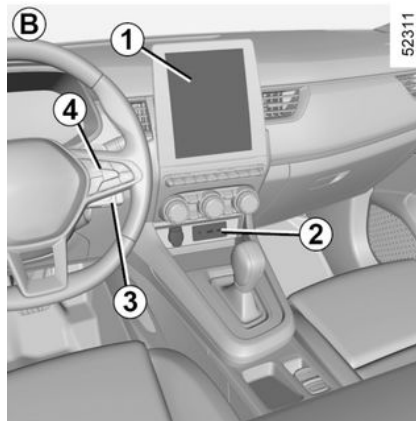

You can use the USB sockets to access the multimedia content of your accessories and to update the system.

The various sources can be selected using the multimedia screen or the radio and the steering column controls.

The sockets USB can also be used to recharge accessories with a maximum power rating of 12 Watts (5 Volts) per socket.

The JACK socket enables the radio to be used with an auxiliary cable.



Connect accessories with a maximum power of 12 watts only.
Fire hazard.

Steering column controls 4

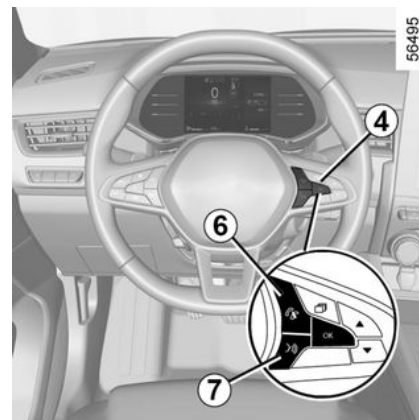

You can use the hands-free telephone **6** and voice recognition **7** controls on vehicles fitted with these.

MULTIMEDIA EQUIPMENT

Microphone 8

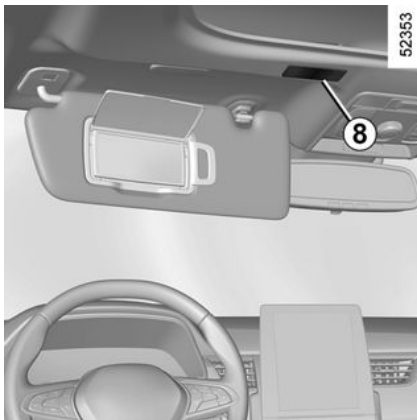

Using the telephone

We remind you of the need to conform to the legislation in force concerning the use of such equipment.

Wireless charger 9

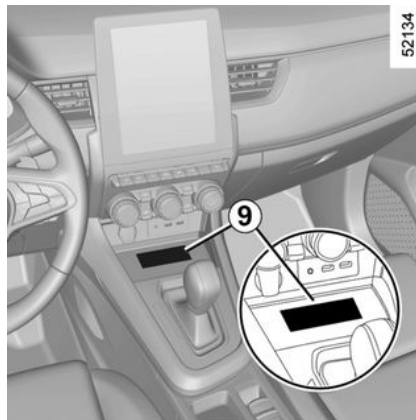

(depending on the vehicle)

➔ 272

Multimedia sockets 10

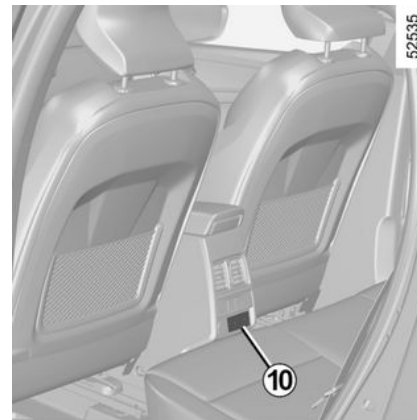

(depending on the vehicle)

You can use the USB sockets.

The sockets USB can be used to recharge accessories with a maximum power rating of 10.5 Watts (5 Volts) per socket, which have been approved by our Technical Department.

MULTIMEDIA EQUIPMENT



Using the telephone

We remind you of the need to conform to the legislation in force concerning the use of such equipment.

PASSENGER COMPARTMENT EQUIPMENT

Electric windows

These systems operate with the ignition on or off, until one of the front doors is opened (limited to about 3 minutes).

4



Driver's responsibility

Never leave your vehicle with the card or key inside, with a child,

adult who is not self-sufficient or a pet in the vehicle, even for a short while.

They may pose a risk to themselves or to others by starting the engine or activating equipment (such as the gear lever or electric windows).

If any part of the body becomes trapped, reverse the direction of the window immediately by pressing the relevant switch.

Risk of serious injury.

One-touch electric windows

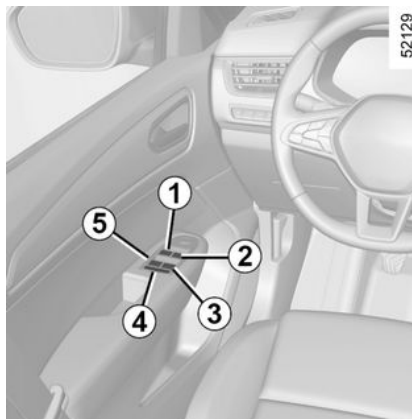

Briefly press or pull a window switch as far as it will go : the window will be raised or lowered fully. Pressing the switch again stops the window moving.

Note : the rear windows do not open fully.

From the driver's seat, use switch :

- 1.** for the driver's side ;
- 2.** for the front passenger side ;
- 3.** and **5** for the rear passengers.

From the passenger seats, use switch **6**.

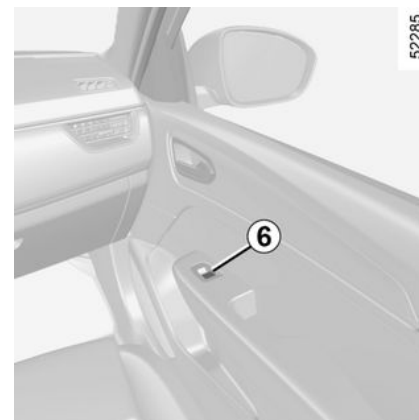

Avoid resting any objects against a half-open window : there is a risk that the electric window winder could be damaged.

PASSENGER COMPARTMENT EQUIPMENT



Passenger safety

The driver can prevent the front and rear passenger electric windows from operating (and the driver's window) by pressing switch **4**. A confirmation message is displayed on the instrument panel.

Note : if the window detects resistance when closing (e.g. tree branch etc.), it stops and then lowers again by a few centimetres.

Remote control window closing

When the doors are locked from the outside, if you **double-press the locking button on the driver's door in hands-free mode, on the card**, all of the windows (and sunroof depending on the vehicle) equipped with a one-touch electric window will close automatically.

It is recommended that the user only operates the system when the vehicle can be seen clearly and no one is inside.

Operating faults

In case of a fault when closing a window, the system reverts to normal mode : pull the switch concerned up as often as necessary to fully close the window (the window will close gradually), hold the switch (still on the closure side) for one second then lower and raise the window fully to reinitialise the system.

If necessary, contact an approved Dealer.



When closing the windows, ensure that no part of the body (arm, hand, etc.) is protruding from the vehicle.

Risk of serious injury.

Electric sunroof

To slide the curtain 1

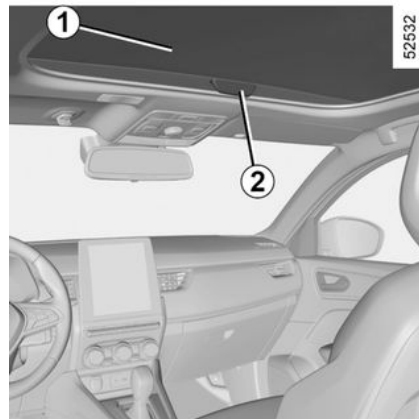

- **To open** : push the handle **2** rearwards to move the blind to the desired position ;
- **to close** : pull the handle **2** forwards to move the blind to the desired position.

PASSENGER COMPARTMENT EQUIPMENT

To slide the sunroof

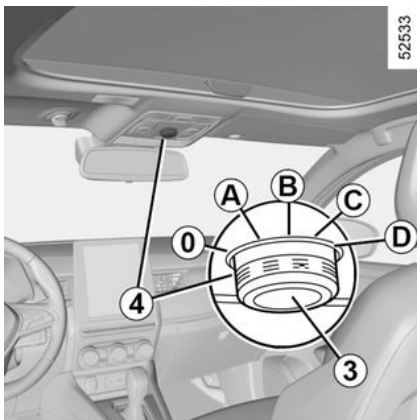

- **To tilt** : move the marked position **3** to position **A** ;
- **to open** : move the marked position **3** to position **B**, **C** or **D** depending on the type of opening required ;
- **to close** : move the marked position **3** to position **0**.



Driver's responsibility

Never leave an animal, child or non-autonomous adult alone in your vehicle, even for a short time.

The reason for this is that the child may endanger himself or others by starting the engine, activating equipment such as the window winders for example, or locking the doors. If something gets trapped, reverse the direction of travel as soon as possible by turning button **4** fully to the right (position **D**).

Risk of serious injury.



If the vehicle is equipped with this function, this action will activate deadlocking.

→ 31

Check that there is no-one still inside the vehicle

Closing the sunroof by remote control

If you **press the locking button on the card twice in quick succession**, the windows and sunroof will close automatically.

It is recommended that the user only operates the system when the vehicle can be seen clearly and no one is inside.



If the vehicle is equipped with this function, this action will activate deadlocking.

→ 31

Check that there is no-one still inside the vehicle

PASSENGER COMPARTMENT EQUIPMENT

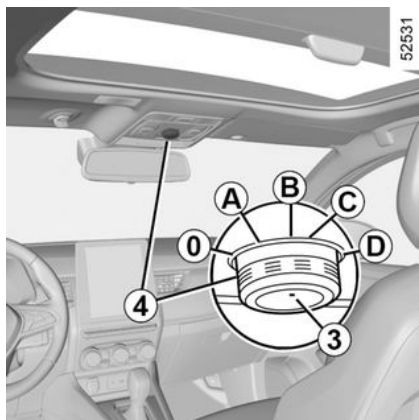

Special features

Your vehicle is fitted with an anti-pinch facility : when the sunroof encounters resistance whilst closing (branch of a tree, etc.), it stops and then moves back a few centimetres.

After closing the sunroof by remote control, pressing button **4** allows the sunroof to return to its previous position.

The sunroof will not open when the temperature is below -20 °C. However, it will still close.



When closing the sunroof, ensure that no part of the body (arm, hand, etc.) is protruding from the vehicle.

Risk of serious injury.

Operating faults

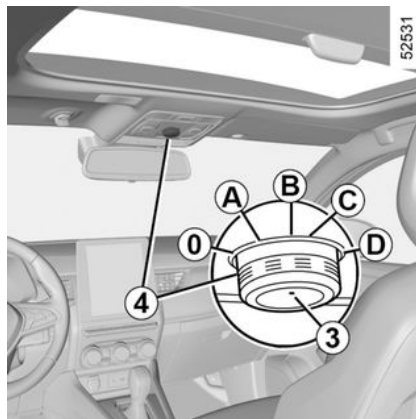

If the sunroof will not close, move the marked position **3** to position **0** then press button **4** until the sunroof is completely closed : consult an approved dealer.



Important : during this operation, the sunroof anti-pinch function is deactivated. Contact your approved Dealer as soon as possible.

Precautions during use

- Vehicle with loaded roof bars.

As a general rule, if there is a load on the roof, use of the sunroof is not recommended.

Before using the sunroof, check the objects and/or accessories (bike racks, roof boxes, etc.) attached to the roof bars : they should be properly arranged and secured and should not interfere with the operation of the sunroof.

Contact an approved dealer for details of possible conversions ;

- **check** that the sunroof is properly closed before leaving your vehicle ;
- **clean** the seal every three months using products recommended by our Technical Department ;
- **do not open** the sunroof immediately after it has rained or immediately after washing the vehicle.

PASSENGER COMPARTMENT EQUIPMENT



Driver's responsibility

Never leave an animal, child or non-autonomous adult alone

in your vehicle, even for a short time.

The reason for this is that the child may endanger himself or others by starting the engine, activating equipment such as the window winders for example, or locking the doors.

If something gets trapped, reverse the direction of travel as soon as possible by turning button **4** fully to the right (position **D**).

Risk of serious injury.

Interior lighting

Courtesy light

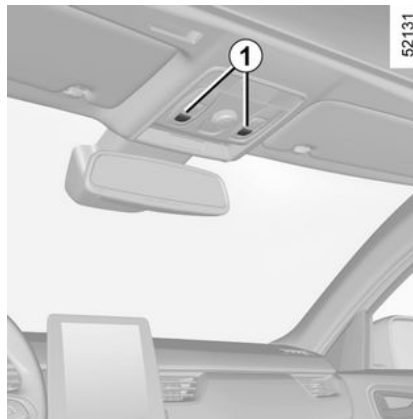

Press switch **1** for :

- permanent lighting ;
- lighting switches off immediately.

Map reading lights A



Press switch **2** for :

- permanent lighting ;
- lighting controlled by the unlocking of the vehicle or by opening one of the doors. This switches off after a time delay, once the doors concerned have been closed correctly ;
- lighting switches off immediately.

PASSENGER COMPARTMENT EQUIPMENT

Map reading lights B

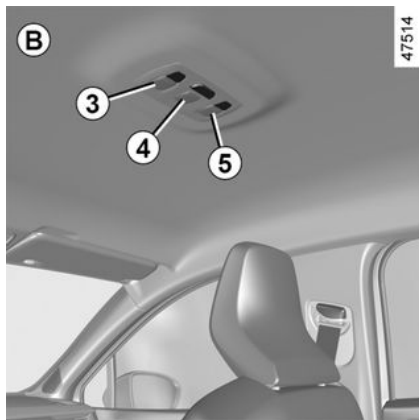

Press switch **3**, **4** or **5** for constant lighting.

Note : on vehicles fitted with a multimedia screen, you can use the multimedia screen to deactivate/activate the reading lights which switch on when the doors or luggage compartment are opened ➔ **105**.

Glove box light

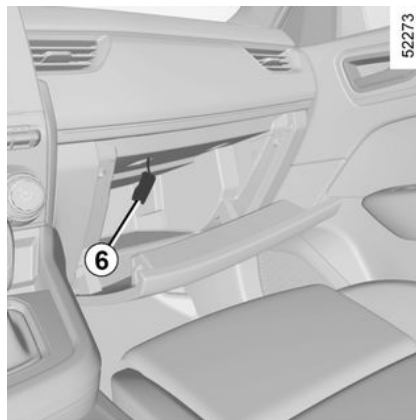

Depending on the vehicle, the **6** light switches on when the cover is opened.

Luggage compartment light

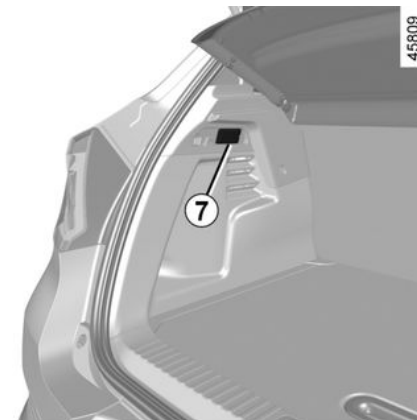

Light **7** comes on when the luggage compartment is opened.

PASSENGER COMPARTMENT EQUIPMENT

Front door ambient light



(depending on the vehicle)

Front door ambient light **8** comes on when the function is activated and the vehicle is unlocked.



Unlocking and opening the doors or tailgate switches on the timed courtesy lights and lights.

Sun visor, mirror

Front sun visor



Lower sun visor **1**.

Courtesy mirrors

(depending on the vehicle)

Lift the cover **2**. The light **3** switches on automatically.



When driving, ensure the courtesy mirror cover is closed.
Risk of injury.



For safety reason, carry out any adjustments when the vehicle is not being driven. **Risk of accident.**

PASSENGER COMPARTMENT EQUIPMENT

Accessories socket

Accessories socket 1

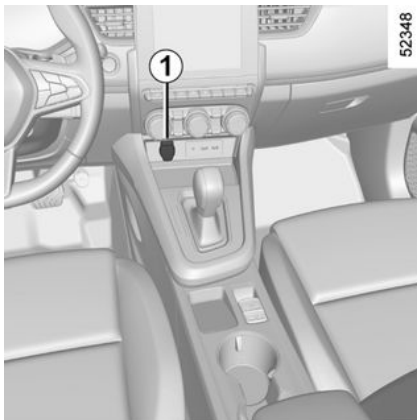

You can use the socket **1**, or **2** depending on the vehicle. It is provided for connecting accessories approved by our Technical Department.

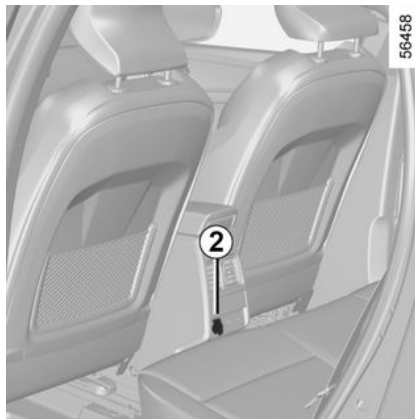

Connect accessories with a maximum power of 120 watts (12 V) only.

When several accessory sockets are used at the same time, the total power of the connected accessories must not exceed 180 watts.

Fire hazard.

PASSENGER COMPARTMENT STORAGE, FITTINGS

Front door storage pockets 1

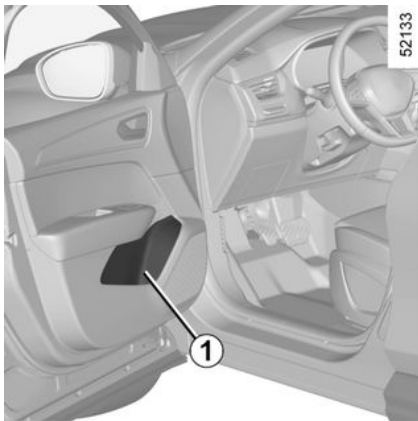

They can hold a 1.5-litre bottle.



Nothing should be placed on the floor area in front of the driver as such objects may slide under the pedal during braking manoeuvres, thus obstructing its use.

Sun blind storage compartment 2



This can be used for storing motorway tickets, cards, etc.



Ensure that no hard, heavy or pointed objects are placed in the "open" storage compartments in such a way that they may fall onto passengers during sudden turning, braking or in the event of an accident.

Centre console storage compartment/induction charging zone 3

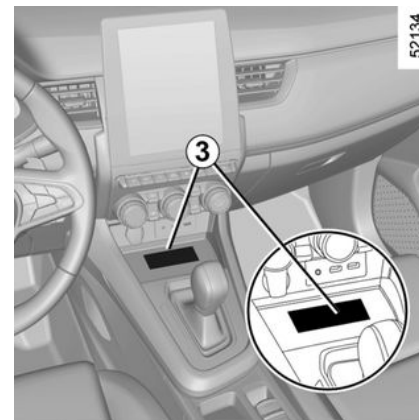

For more information on the induction charging zone, please refer to the multimedia instructions.

PASSENGER COMPARTMENT STORAGE, FITTINGS

Centre console pocket 4

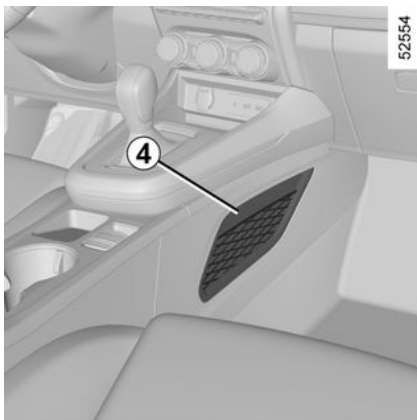

Ensure that no hard, heavy or pointed objects are placed in the "open" storage compartments in such a way that they may fall onto passengers during sudden turning, braking or in the event of an accident.

Passenger storage compartment

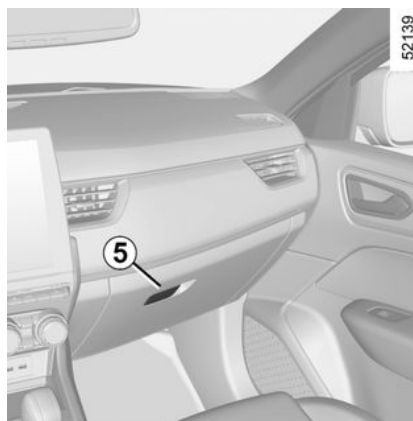

Pull handle **5** to open it.
The glove box can hold A4-sized documents, a bottle etc.

Cup holders 6

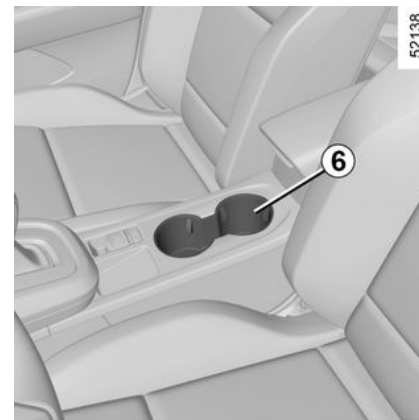

Depending on the vehicle, the cup holder may be equipped with retaining hooks to keep the cup in place.
This can be used to store a mobile ashtray, drink cans, etc.

PASSENGER COMPARTMENT STORAGE, FITTINGS

Centre armrest storage compartment 9



Lift the cover **7** of the sliding armrest by pressing the **8** button.

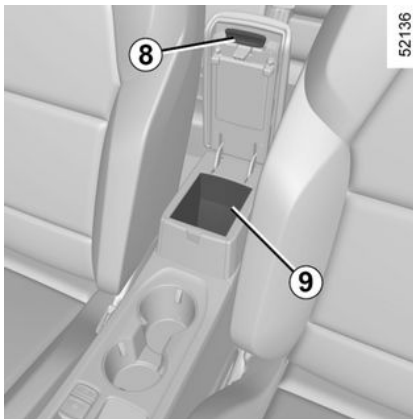

When turning corners, accelerating or braking, ensure that the receptacle being held by the cup holder is not dislodged. **There is a risk of injury if hot liquid escapes.**

Rear door storage compartment 10

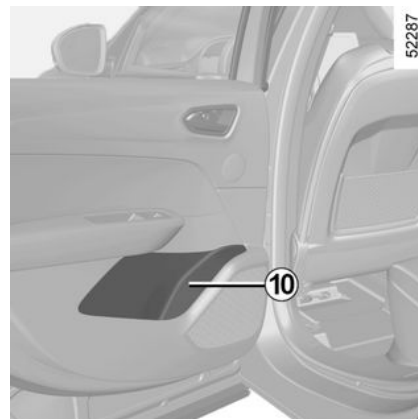

They can hold a 0.5-litre bottle.

PASSENGER COMPARTMENT STORAGE, FITTINGS

Rear seat storage pockets 11

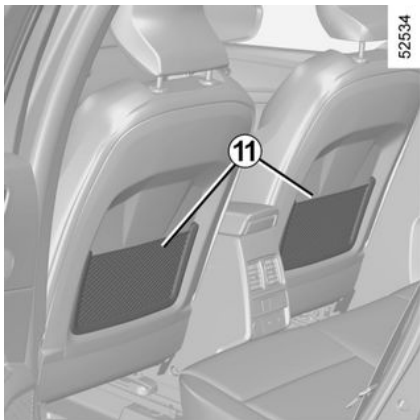

Ensure that no hard, heavy or pointed objects are placed in the "open" storage compartments in such a way that they may fall onto passengers during sudden turning, braking or in the event of an accident.

Grab handle 12

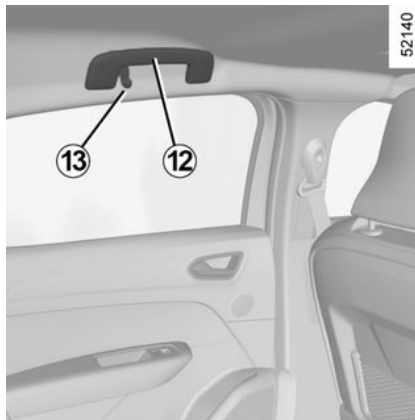

This offers support and can be held when the vehicle is moving.
Do not use it for getting into or out of the vehicle.

Clothes hook 13

Rear seat cup holder 14

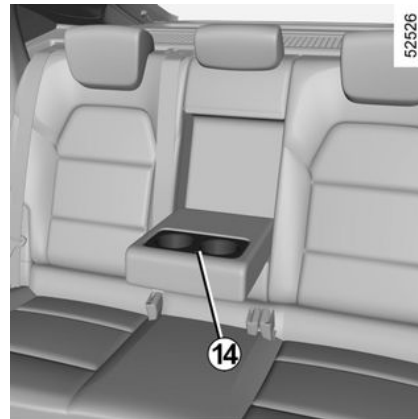

Lower the rear seat armrest.

TRANSPORTING OBJECTS

Luggage compartment storage

Mobile floor 1

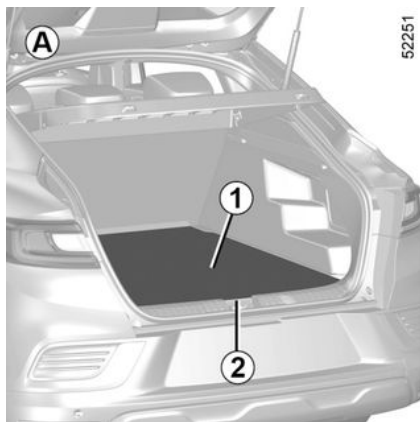

(depending on the vehicle)

Mobile floor **1** position can be changed as below.

Flat position **A**

Enables you to flatten the floor by folding down the back of the rear bench seat and to compartmentalise the boot into two distinct spaces.

The mobile floor is positioned on the runner.

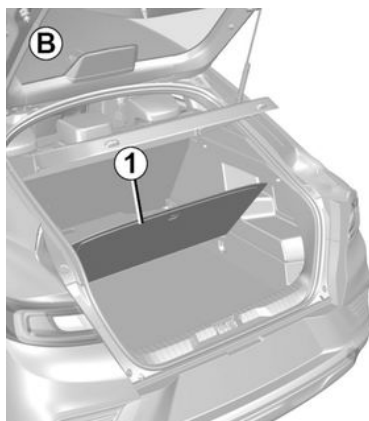

Intermediate position **B**

In the position **A**, it allows you to use under the floor **1** and access the tools stored under the boot carpet.

 Maximum weight for the mobile floor : 100 kg evenly distributed.

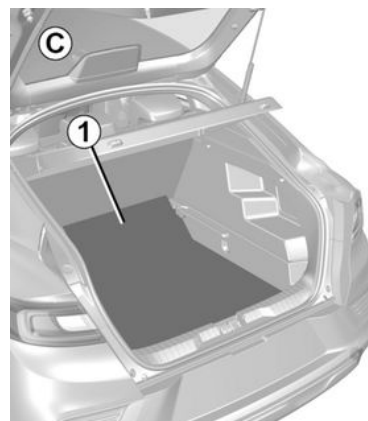

Storage position **C**

This position allows for more space to store things in the boot.

 When removing the mobile floor out of the luggage compartment, lift it by more than 30 degrees. If it is not lifted enough, damage may occur around the tailgate.

TRANSPORTING OBJECTS

Rear parcel shelf

Removal

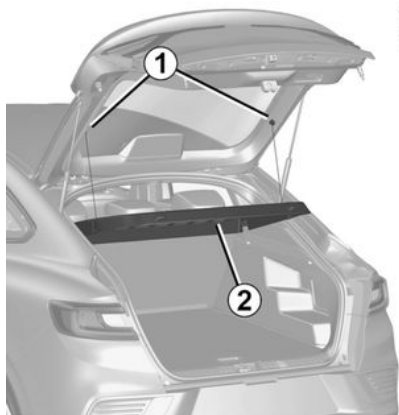

- Unhook the two straps **1** of the door of the boot;
- lift the shelf **2** to unclip it (movement **A**);
- pull the shelf towards you.

To refit, proceed in the reverse order to removal.

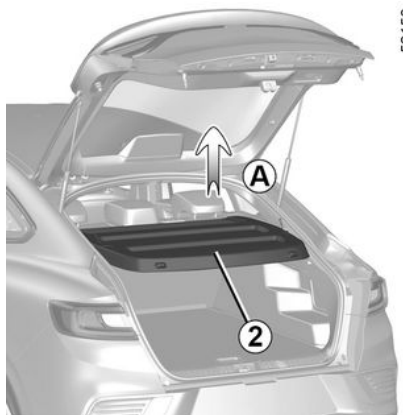

Do not place any heavy or hard object on the parcel shelf. These may pose a risk to the vehicle occupants if the driver has to brake suddenly or if the vehicle is involved in an accident.

Transporting objects in the luggage compartment

Always position the objects transported so that the largest surface is against :



the rear bench seatback, for normal loading (example **A**)



the front seatbacks with the rear seatbacks folded down, as is the case for maximum loads (example **B**)

Ensure that the objects being transported are evenly distributed throughout the loading area.

If you have to place objects on the folded seatback, it is necessary that you lower the headrests before folding the seatback so that it can be folded as flat as possible against the seat.

Note : in the absence of an emergency spare wheel or tyre inflation kit, do not load the bottom of the luggage compartment.

TRANSPORTING OBJECTS

Towbar



Permissible nose weight, maximum permissible towing weight braked and unbraked : → 338.

Choice and fitting of towing equipment

Maximum weight of towing equipment :

- 35 kg on a vehicle with towing pre-equipment ;
- 28 kg on a vehicle without towing pre-equipment.

Any towing device must not obstruct any lighting component or the number plate when not in use.

In all cases, you must comply with the regulations of the particular country you are in.

For fitting and conditions of use, refer to the equipment's fitting instructions.

Please keep these instructions with the rest of the vehicle documentation.

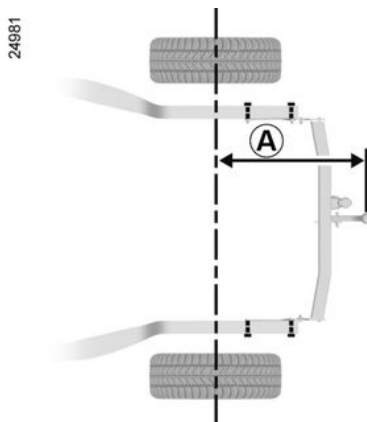

Maximum dimension **A** : 1097 mm.

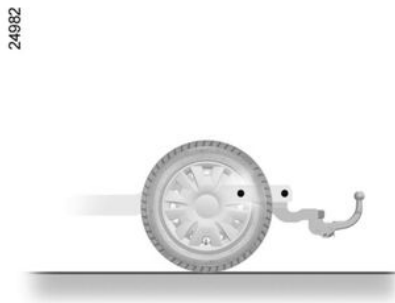

Roof bars

Roof bars

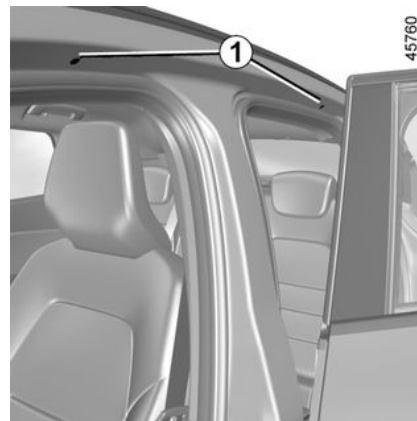

Open the doors to access the fixing points **1**.

Precautions during use

Handling the tailgate

Before handling the tailgate, check the objects and/or accessories (bike rack, roof box, etc.) fitted to the roof bars : these must be correctly positioned and secured, so as not to hinder the operation of the tailgate.

TRANSPORTING OBJECTS



If original roof bars, approved by our Technical Department, are supplied with screws, only use these screws for attaching the roof bars to the vehicle.



For information on the range of equipment adapted to your vehicle, we advise you to consult an approved Dealer. Refer to the fitting instructions for information on how to fit roof bars and conditions of use. Please keep these instructions with the rest of the vehicle documentation.

Maximum permissible load on roof rack. → 338

Antenna



On equipped vehicle, pole type antenna **2** can be removed by turning it anti-clockwise.



It is prohibited to attach any carrying equipment (bike rack, luggage box etc.) resting against the spoiler or tailgate. To install a carrying device on your vehicle, contact an Approved Dealer.

ACCESSING THE ENGINE, LEVELS

Bonnet

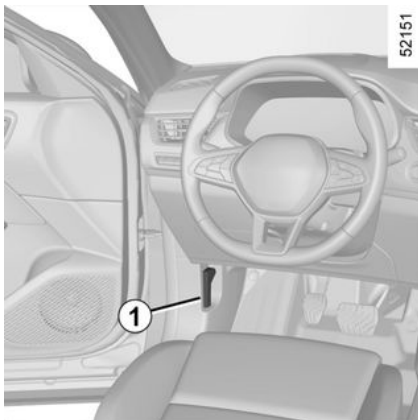

To open the bonnet, open a door and pull the **1** handle, located on the left-hand side of the dashboard.



Before carrying out any action in the engine compartment, you must switch off the ignition. or → **128**



Do not press down on the bonnet : there is a risk that the bonnet may accidentally close.

Unlocking the bonnet catch



To unlock, push tab **2** at the same time as opening the bonnet.



Please note when working close to the engine that it may be hot. The engine cooling fan may also start at any mo-

ment. The  label in the engine compartment reminds you of this.

Risk of injury.

Opening the bonnet

-Slightly lift the bonnet :

2. -push the tab towards the left (without lifting the bonnet) to unlock the safety mechanism ;

-then lift the bonnet.

Note : safety unlocking may not take place if you lift the bonnet and move the tab **2** simultaneously.

Lift the bonnet, guiding it up, and it will rest in position with the help of two struts **3**.

ACCESSING THE ENGINE, LEVELS



When working in the engine compartment, ensure that the windscreen wiper stalk is in the park position.

Risk of injury.



After any procedure in the engine compartment, make sure that you do not forget anything (cloth, tools, etc.). These may damage the engine or cause a fire.



In the event of even a slight impact involving the radiator grille or bonnet, have the bonnet lock checked by an approved dealer as soon as possible.



Ensure that the bonnet is properly locked. Check that nothing is preventing the catch from locking (gravel, cloth, etc.).

Closing the bonnet

Before closing the bonnet, make sure that nothing has been left in the engine compartment.

To close the bonnet, hold the bonnet in the middle and lower it to 30cm above the closed position, then push the bonnet with your hands slightly towards the closing direction until it is completely closed.

Engine oil

General information

A combustion engine uses oil for lubrication and cooling of moving parts and it is normal to top up the level between oil changes.

However, contact your approved Dealer if more than 0.5 litres is being consumed every 600 miles (1,000 km) after the running in period.

Oil change frequency : check the oil level from time to time and certainly before any long journey to avoid the risk of damaging your engine.

Reading the oil level

The oil level should be read with the vehicle on level ground, after the engine has been switched off for some time.

The dipstick must be used to read the exact oil level and make sure that the maximum level has not been exceeded (risk of engine damage).

Depending on the vehicle, the instrument panel display only alerts the driver when the oil level is at its minimum.

ACCESSING THE ENGINE, LEVELS

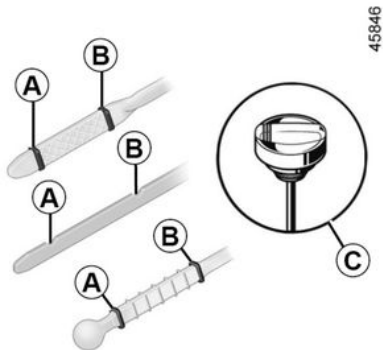

5

- Remove the dipstick and wipe with a clean, lint-free cloth ;
- push the dipstick in as far as it will go (for vehicles equipped with a cap-type dipstick **C**, screw the cap in as far as it will go) ;
- take out the dipstick again ;
- read the level : it should never fall below the "mini" mark **A** and never exceed the "maxi" **B** mark.

Once the operation has been completed, ensure that the dipstick is pushed in as far as it will go or that the "cap-type dipstick" is completely screwed in.



Adding engine oil

Use a funnel or protect the filling neck area to avoid engine oil escaping on to a hot part of the engine compartment or a sensitive part (e.g. electrical components).

Fire hazard.



Exceeding the maximum engine oil level

Under no circumstances must the maximum fill level **B** be exceeded : risk of damage to the engine and catalytic converter.

If the oil level exceeds the maximum level, **do not start your vehicle** and contact an approved Dealer.



Before carrying out any action in the engine compartment, you must switch off the ignition. ➔ **128**

Topping up, filling, oil change

Topping up/filling

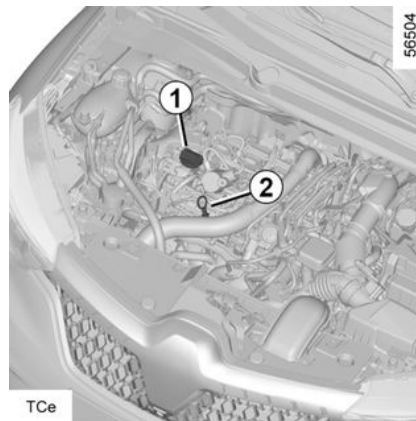

TCe

ACCESSING THE ENGINE, LEVELS

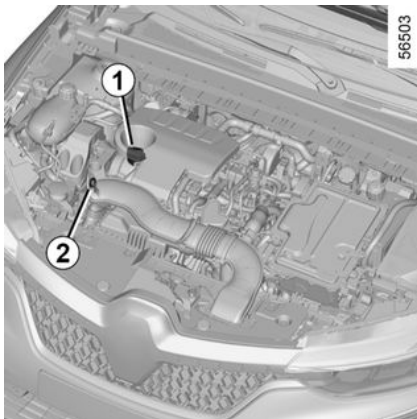

The vehicle must be parked on level ground and the engine should be cold (for instance, before the engine is started up for the first time in the day).



Do not exceed the "maxi" level and do not forget to refit the cap **1** and the dipstick **2**.

- Unscrew cap **1** ;
- top up the level (capacity between "mini" and "maxi" of the gauge **2** and between 0.9 to 2 litres according to the engine) ;

- wait for approximately 20 minutes to allow the oil to flow into the engine ;
- check the level using the dipstick **2** (as described above).

Once the operation has been completed, ensure that the dipstick is pushed in as far as it will go or that the cap-type dipstick is completely screwed in.



Before carrying out any action in the engine compartment, you must switch off the ignition. or → **128**.



Adding engine oil
Use a funnel or protect the filling neck area to avoid engine oil escaping on to a hot part of the engine compartment or a sensitive part (e.g. electrical components).

Fire hazard.

Oil change

Service interval : refer to the Maintenance Service Booklet for your vehicle.

Oil change capacity

Please refer to the maintenance document for your vehicle, or contact an authorised dealer. Always check the engine oil level using the dipstick, as explained previously (it should never fall below the minimum level, or be over the maximum level on the dipstick).

Engine oil grade

Refer to the Maintenance Service Booklet for your vehicle.



Consult your approved dealer at once if you notice an abnormal or repeated drop in any of the fluid levels.

ACCESSING THE ENGINE, LEVELS



Filling and/or checking the oil level : when topping up or checking the oil level, ensure that no

oil leaks onto engine components.

Do not forget to properly close the cap and refit the dipstick to prevent and oil spatter on hot engine components.

Fire hazard.



When working in the engine compartment, ensure that the windscreen wiper stalk is in the park position.

Risk of injury.



Please note when working close to the engine that it may be hot. The engine cooling fan may also start at any mo-

ment. The  label in the engine compartment reminds you of this.

Risk of injury.



Exceeding the maximum engine oil level

Under no circumstances must the maximum fill level be exceeded : risk of damage to the engine and catalytic converter.

If the oil level exceeds the maximum level, **do not start your vehicle** and contact an approved Dealer.



Never run the engine in an enclosed space as exhaust gases are poisonous.



Engine oil change : if you are changing the oil when the engine is hot, be careful not to scald yourself if the oil overflows.

ACCESSING THE ENGINE, LEVELS

Coolant level

Combustion engine coolant

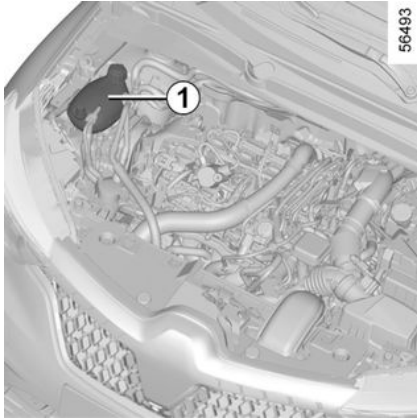

With the engine switched off and on level ground, the level **when cold** must be between the "MINI" and "MAXI" marks on coolant reservoir **1**. Top this level up **when cold** before it reaches the MINI mark.

Frequency of checking coolant level

Check the coolant level regularly (very severe damage is likely to be caused to the engine if it runs out of coolant).

If the level needs to be topped up, only use products approved by our

Technical Department which ensure:

- protection against freezing ;
- an anti-corrosion protection for the cooling system.



Before carrying out any action in the engine compartment, you must switch off the ignition. → 128.

Replacement interval

Refer to the Maintenance Document for your vehicle.



When working in the engine compartment, ensure that the wind-screen wiper stalk is in the park position.
Risk of injury.



Consult your approved dealer at once if you notice an abnormal or repeated drop in any of the fluid levels.



No operations should be carried out on the cooling circuit when the engine is hot.
Risk of burns.

Electric traction system coolant

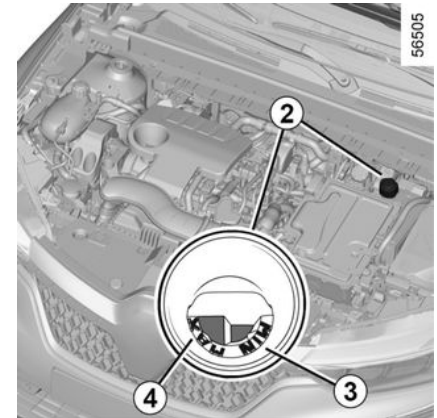

ACCESSING THE ENGINE, LEVELS

On E-Tech full hybrid version, this system is different to that of the combustion engine. It is used for cooling the electric motor.

Reading the level

With the ignition off and the vehicle parked on level ground, unscrew the cap from the coolant reservoir **2**.

When **cold**, the level should be located between the "MIN" **3** and "MAX" **4** markings inside the funnel.

Frequency of checking coolant level

Check the coolant level regularly (very severe damage is likely to be caused to the electrical circuit if it runs out of coolant).

If a top-up is required, you must contact an approved dealer to perform the top-up.



Before carrying out any action in the engine compartment, you must switch off the ignition. → **128**

Replacement interval

Refer to the Maintenance Document for your vehicle.



Consult your approved dealer at once if you notice an abnormal or repeated drop in any of the fluid levels.



When working in the engine compartment, ensure that the windscreen wiper stalk is in the park position.

Risk of injury.



No operations should be carried out on the cooling circuit when the combustion engine

is hot.

Risk of burns.

Levels, filters

Brake fluid

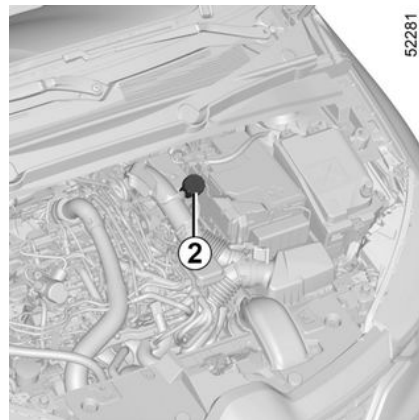

This should be checked frequently, and immediately if you notice even the slightest loss in braking efficiency.

The level should be read with the engine switched off and on level ground.

Level 2

It is normal for the level to drop as the brake shoes become worn, but it must never drop lower than the "MIN" warning line indicated by the '▲ triangle marking' depending on the vehicle.

ACCESSING THE ENGINE, LEVELS

If you wish to check the disc wear yourself, you should obtain the document explaining the checking procedure from the manufacturer's network or website.

Topping up

After any operation on the hydraulic circuit, a specialist must replace the brake fluid.

Only use fluids approved by our Technical Department (and taken from a sealed container).

Replacement interval

Refer to the Maintenance Document for your vehicle.



Consult your approved dealer at once if you notice an abnormal or repeated drop in any of the fluid levels.



Before carrying out any action in the engine compartment, you must switch off the ignition.



When working in the engine compartment, ensure that the windscreen wiper stalk is in the park position.

Risk of injury.



Please note when working close to the engine that it may be hot. The engine cooling fan may also start at any mo-

ment. The  label in the engine compartment reminds you of this.

Risk of injury.

Windscreen washer reservoir

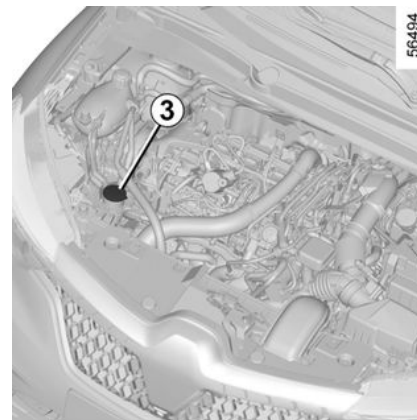

5

Topping up

With the engine switched off, open the cap **3**. Fill until you can see the fluid, then replace the cap.

Note: check the reservoir level regularly and top up the liquid before taking a trip.

Liquid

Only use windscreen washer fluid containing antifreeze.

We advise you to consult an authorised dealer or a qualified professional.

Note: do not use pure water (risk of damage to the priming pump,

ACCESSING THE ENGINE, LEVELS

limescale building up on the pump and the jets).

Jets

To adjust the height of the wind-screen washer jets, please consult an authorised dealer.



Before carrying out any action in the engine compartment, you must switch off the ignition. → 128



Please note when working close to the engine that it may be hot. The engine cooling fan may also start at any mo-

ment. The  label in the engine compartment reminds you of this.

Risk of injury.

Filters

The replacement of filter components (air filter, cabin filter, diesel filter, etc.) is scheduled in the maintenance operations for your vehicle.

Replacement intervals for filter elements: refer to the Maintenance Document for your vehicle.



When working in the engine compartment, ensure that the wind-screen wiper stalk is in the park position.

Risk of injury.

BATTERY

12V battery

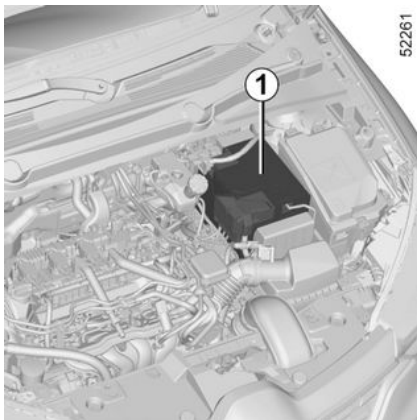

The 12V battery **1** does not require any maintenance. (On E-Tech full hybrid version, it is located in the luggage compartment.) **You should not open it or add any fluid.**



Handle the battery with care as it contains sulphuric acid which must not come into contact with the eyes or skin. If it does, wash the affected area with plenty of cold water. If necessary, consult a doctor. Ensure that naked flames, red hot objects and sparks do not come into contact with the battery as there is a risk of explosion.

Depending on the vehicle, a system continuously checks the battery charge status. If this decreases, the "Battery Now In Standby Mode" message appears on the instrument panel followed by "Battery Low Start Engine". In this case, start the engine and the message on the instrument panel will disappear.

Note : the message "Battery Now In Standby Mode" may be displayed after 5 to 30 minutes of vehicle use with the engine stopped to warn the user that power consuming functions (interior lighting, radio, navigation, ventilation, accessories power

supply, etc.) may be automatically cut off.

The charge status of your battery can decrease especially if you use your vehicle :

- for short journeys ;
- in an urban setting ;
- when the temperature is low ;
- after extended use of energy-consuming devices (radio, etc.) with the engine switched off ;
- after a prolonged period of parking.



Before carrying out any action in the engine compartment, you must switch off the ignition. ➔ **128.**

BATTERY



Please note when working close to the engine that it may be hot. In addition, the engine cooling fan may start at

any moment. The  warning light in the engine compartment reminds you of this.

Risk of injury.



For your own safety and to ensure the proper operation of the vehicle's electrical equipment (lights, windscreen wipers, ABS etc.), any intervention on the 12V battery (removal, disconnection etc.) must **ALWAYS** be performed by a specialist professional.

Risk of serious burns or electric shocks.

Respect **categorically** the replacement intervals (without exceeding them) as stated in the maintenance document. The battery is a specific type. Please ensure it is replaced with the same type. Call an approved Dealer.

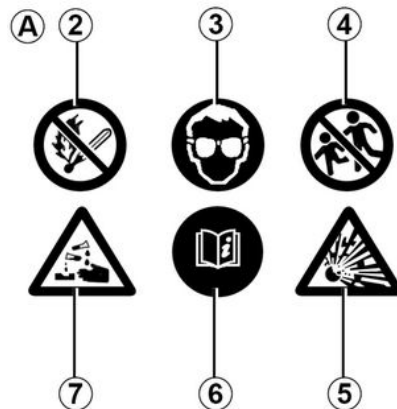

28705

Label A

Observe the indications on the battery :

- 2** naked flames and smoking are forbidden ;
- 3** eye protection required ;
- 4** keep away from children ;
- 5** flammable materials ;
- 6** please consult the vehicle user manual ;
- 7** corrosive substances.

BATTERY



Do not disconnect the 12V battery.

Risk of serious burns or electric shocks.

Replacing the battery

As this operation is complex, we advise you to contact an approved Dealer.



For your own safety and for the proper operation of the vehicle's electrical equipment

(lights, windscreen wipers, ABS, etc.), any intervention on the battery (removal, disconnection, etc.) must categorically be performed by a specialist professional.

Risk of serious burns or electric shocks.

You must respect the replacement intervals (without exceeding them) as stated in the maintenance document.

The battery is a specific type.

Please ensure it is replaced with the same type.

Call an approved Dealer.

Secondary battery

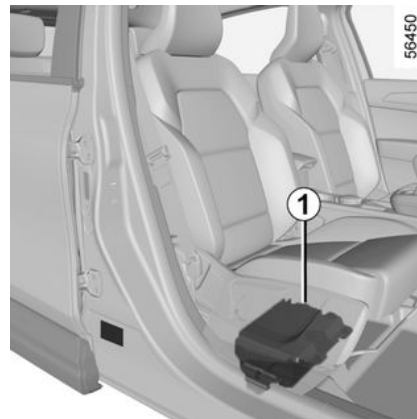

Depending on the vehicle, a secondary battery **1** is located under the front passenger seat in a specific compartment: it supplies the energy required to operate some equipment.

The secondary battery **1** does not require any maintenance. **You should not open it or add any fluid.**

5

BATTERY

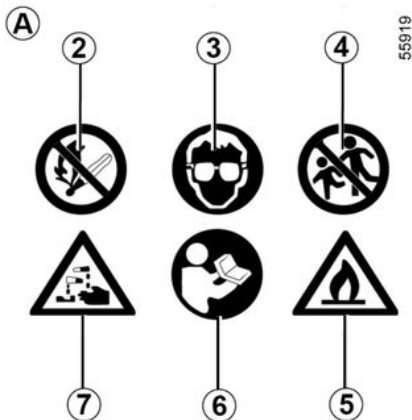

Label A

Label A is located on the battery *1*:

2 naked flames and smoking are forbidden;

3 eye protection required;

4 keep away from children;

5 flammable materials;

6 please consult the vehicle user manual;

7 corrosive substances.



For your own safety and for the proper operation of the vehicle's electrical equipment

(lights, windscreen wipers, ABS, etc.), any intervention on the battery (removal, disconnection, etc.) must categorically be performed by a specialist professional.

Risk of serious burns or electric shocks.

The battery is a specific type. Please ensure it is replaced with the same type. Call an approved Dealer.

CLEANING

Bodywork maintenance

A well-maintained vehicle will last longer. It is therefore recommended to maintain the exterior of the vehicle regularly.

Your vehicle has been treated with very effective anti-corrosion products. It is nevertheless subject to various outside influences.

Corrosive agents in the atmosphere

- atmospheric pollution (built-up and industrial areas);
- saline atmospheres (near the sea, particularly in hot weather);
- seasonal and damp weather conditions (e.g. road salt in winter, water from road cleaners, etc.).

Minor impacts

Abrasive action

Dust and sand in the air, mud, road grit thrown up by other vehicles, etc. You should take a number of minor precautions in order to safeguard your vehicle against such risks.

You should do the following

Wash your car frequently, **with the engine off**, with cleaning products recommended by the manufacturer (never use abrasive products). Rinse

thoroughly beforehand with a jet washer:

- spots of tree resin and industrial grime;
- mud in the wheel arches and underneath the body which forms damp patches;
- **bird droppings, which cause a chemical reaction with the paint that rapidly discolours paintwork and may even cause the paint to peel off;**

wash the vehicle **immediately** to remove these marks since it is impossible to remove them by polishing;

- salt, particularly in the wheel arches and underneath the body after driving in areas where the roads have been gritted.

Remove any plant matter (resin, leaves, etc.) from the vehicle regularly.

Respect local regulations about washing vehicles (e.g. do not wash your vehicle on a public highway).

Observe the vehicle stopping distances when driving on gravelled surfaces to prevent paint damage.

Repair, or have repaired quickly, areas where the paint has been damaged, to prevent corrosion spreading.

Remember to visit the body shop periodically in order to maintain your anti-corrosion warranty. Refer to the Maintenance Document.

When washing the vehicle with a highpressure cleaning device, please take the following precautions:

- make sure that your vehicle's paintwork, the area or the component that you want to clean is compatible with this type of washing;
- the pressure delivered by the device must be less than 100 bar;
- when washing, position the spray nozzle at least 15 cm from the vehicle and check that the water flow rate is less than 3.30 gal (15 l)/min;
- do not persist in washing the same area, impacted points or the seals (risk of damage to the paint, seals becoming detached, etc.).

If it is necessary to clean mechanical components, hinges, etc., spray them with products approved by our Technical Department to protect them after they have been cleaned.

CLEANING



We have selected special products to care for your vehicle and you can obtain these from the manufacturer's accessory outlets.

Do not do the following

5 Wash the vehicle in bright sunlight or freezing temperatures.

Do not scrape off mud or dirt without pre-wetting.

Allow dirt to accumulate on the exterior.

Allow rust to form following minor impacts.

Do not use solvents not approved by our Technical Department to remove stains as this could damage the paintwork.

Do not drive in snow or muddy conditions without washing the vehicle, particularly under the wheel arches and body.



Degrease or clean using high-pressure cleaning equipment or by

spraying on products not approved by our Technical Department :

- mechanical components (e.g. : engine compartment) ;
- underbody ;
- parts with hinges (e.g. : inside the doors) ;
- painted plastic external fittings (e.g. : bumpers).

Doing this could give rise to corrosion or operational faults.

Vehicles with a matte paint finish

This type of paint requires certain precautions.

You should do the following

Wash the vehicle by hand using plenty of water, using a soft cloth or a gentle sponge.

Do not do the following

- Use wax-based products (polishing).
- Rub too hard.
- Wash the vehicle in a roller-type car wash.
- Attach stickers to the paintwork (risk of leaving marks).



Wash the vehicle using a high-pressure cleaning device.

Using a roller type car wash

Return the windscreen wiper stalk to the Park position. → 120. Check the mounting of external accessories, additional lights and rear view mirrors, and ensure that the wiper blades are secured with adhesive tape.

Remove the radio aerial mast if your vehicle is fitted with this equipment.

Remember to remove the tape and refit the antenna after washing.

Cleaning the headlights, sensors and cameras

Use a soft cloth or cotton wool. If this does not clean them properly, moisten the cloth with soapy water, then wipe clean with a soft damp cloth or cotton wool.

Finally, carefully dry off with a soft dry cloth.

Do not use cleaning products containing alcohol or utensils (e.g. : a scraper).

Cleaning stickers, decorative films, etc.

You should do the following

CLEANING

Use a soft cloth or cotton wool.

Moisten it with soapy water, then always wipe clean with a soft cloth or cotton wool.

Finally, carefully dry off with a soft dry cloth.

Do not do the following

Use alcohol-based cleaning products.

Use utensils (e.g. scraper).

Rub too hard.



Wash the vehicle using a high-pressure cleaning device.

Interior trim maintenance

A well-maintained vehicle will last longer. It is therefore recommended to maintain the interior of the vehicle regularly.

A stain should always be dealt with swiftly.

Whatever type of stain is on the trim, use **cold (or warm) soapy water with natural soap**.

Detergents (washing-up liquid, powdered products, alcohol-based products) should not be used.

Use a soft cloth.

Rinse and soak up the excess.

Glass instrument panel

(e.g. instrument panel, clock, exterior temperature display, radio display, etc.)

Use a soft cloth (or cotton wool).

If this does not clean them properly, use a soft cloth (or cotton wool) slightly moistened with soapy water and then wipe clean with another soft damp cloth or cotton wool.

Finally, **carefully** dry off with a soft dry cloth.

Do not use products containing alcohol and/or spray fluids on the area.

Seat belts

These must be kept clean.

Use products selected by our Technical Department (Approved outlets) or warm, soapy water and a sponge and wipe with a dry cloth.

Detergents or dyes must not be used under any circumstances.

Textiles (seats, door trim, etc)

Vacuum-clean the textiles **regularly**.

Liquid stain

Use soapy water.

Dab lightly (never rub) with a soft cloth, rinse and remove the excess.

Solid or pasty stain

Carefully remove the excess solid or pasty material **immediately** with a spatula (working from the edges to the centre to avoid spreading the stain).

Clean as for a liquid stain.

Special instructions for sweets or chewing gum

Put an ice cube on the stain to solidify it, then proceed as for a solid stain.



For further recommendations for maintaining the interior, and/or for any unsatisfactory results, please see an authorised dealer.

Removal/replacing removable equipment originally fitted in the vehicle

If you need to remove equipment in order to clean the passenger compartment (for example, mats), always ensure that they are correctly refitted and are the right way around (the driver's mat should be fitted on the driver's side, etc.) and fit them with the components supplied

CLEANING

with the equipment (for example, the driver mat should always be fixed using the pre-fitted mounting components).

With the vehicle stationary, always ensure that nothing will impede driving (anything obstructing the pedals, heel wedged by the mat etc.).

Do not do the following

Position objects such as deodorants, scents etc. near air vents as this could damage your dashboard trim.



Use high-pressure cleaning equipment or sprays inside the passenger compartment :

without careful use, this equipment could impair the correct functioning of the electrical or electronic components in the vehicle, or have other detrimental effects.

5

TYRES

Tyres

Tyre and wheel safety

The tyres are the only contact between the vehicle and the road, so it is essential to keep them in good condition.

You must make sure that your tyres conform to local road traffic regulations.

Maintaining the tyres

The tyres must be in good condition and the tread form must have sufficient depth; tyres approved by our Technical Department have wear warning strips **1** which are **indicators moulded into the tread at several points**.



Incidents which occur when driving, such as striking the kerb, may damage the tyres and wheel rims, and could also lead to misalignment of the front or rear axle geometry. In this case, have the condition of these checked by an approved dealer.



When the tyre tread has been worn to the level of the warning strips, **they become visible 2 : it is then necessary to replace your tyres because the tread rubber is now only 1.6 mm deep at most, resulting in poor road holding on wet roads.**

An overloaded vehicle, long journeys by motorway, particularly in very hot weather, or continual driving on poorly surfaced minor roads will lead to more rapid tyre wear and affect safety.

Tyre pressures

Adhere to the tyre pressures (including the emergency spare wheel). The tyre pressures should be checked at

least once a month and additionally before any long journey (refer to the label affixed to the edge of the driver's door).



Incorrect tyre pressures lead to abnormal tyre wear and unusually hot running. These are factors which may seriously affect safety and lead to :

- poor road holding ;
- risk of bursting or tread separation.

The pressure depends on the load and the speed of use. Adjust the pressure according to the conditions of use (refer to the label affixed to the edge of the driver's door).

Pressures should be checked when the tyres are cold ; ignore higher pressures which may be reached in hot weather or following a fast journey.

If tyre pressures cannot be checked when the tyres are **cold, assume an increase of 0.2 to 0.3 bar (or 3 PSI)**.

Never deflate a hot tyre.

TYRES



Please be aware that a poorly tightened or missing valve cap can make the tyres less airtight and lead to pressure loss. Always use valve caps identical to those fitted originally and tighten them fully.

Vehicle fitted with a tyre pressure loss warning system

In the event of under-inflation (punctures, under-inflation etc.), the  warning light appears on the instrument panel. → 159

Emergency spare wheel

→ 304, → 306

Changing wheels around

This practice is not recommended.

Fitting new tyres



For your safety, please respect the speed limit. When they need to be replaced, only tyres of the same make, size, type and profile should be used on a single axle.

They must either have a load capacity and speed rating at least equal to those of the original tyres, or be recommended by an authorised dealer.

Failure to heed these instructions could endanger your safety and affect your vehicle's roadworthiness.

Risk of loss of control of the vehicle.

Use in winter

Chains

For safety reasons, fitting snow chains to the rear axle is strictly forbidden.

Chains cannot be fitted to tyres which are larger than those originally fitted to the vehicle.

One-way tyres

An one-way tyre must only be fitted in one direction. You must observe this direction.

If an one-way tyre must be fitted in the opposite to its direction of rotation following a puncture, drive with caution, particularly on a wet road, because the tyre specifications will not be adapted.



Chains may only be fitted to tyres of the same size as those originally fitted to **your vehicle.**

Snow or Winter tyres

We would recommend that these be fitted to all **four wheels** to ensure that your vehicle retains maximum adhesion.

Warning: These tyres sometimes have a specific direction of rotation and a maximum speed index which may be lower than the maximum speed of your vehicle.

Studded tyres

This type of equipment may only be used for a limited period and as laid down by local legislation. It is neces-

TYRES

sary to observe the speed specified by current legislation.

These tyres must, at a minimum, be fitted to the two front wheels.



18", 19" wheels cannot be fitted with chains.

If you wish to fit snow chains, you must use

special equipment.

Consult an approved dealer



In all cases, we would recommend that you contact an approved Dealer who will be able to advise you on the choice of equipment which is most suitable for your vehicle.

Tyre pressure

Label A

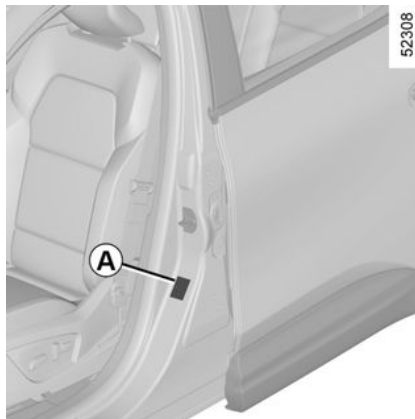

Open the driver's door to read it.

Tyre pressures should be checked when the tyres are cold.

If the tyre pressures cannot be checked when the tyres are **cold, increase the pressures from 0.2 to 0.3 bar (or 3 PSI). Never deflate a hot tyre.**

Vehicle fitted with a tyre pressure loss warning system

In the event of under-inflation (punctures, under-inflation etc.), the 

warning light appears on the instrument panel → 159.

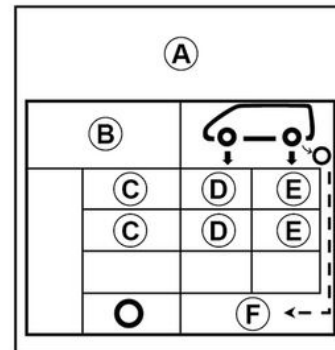

B. : dimension of the tyres fitted to the vehicle.

C. : intended driving speed.

D. : front tyre pressure.

E. : rear tyre pressure.

F. : tyre pressure for the emergency spare wheel.

TYRES



Vehicles used fully laden (Maximum Permissible All-up Weight) and towing a trailer

The maximum speed must be limited to **62 mph (100 km/h) and the tyre pressure increased by 0.2 bar (3 psi) → 338.**
Risk of tyre blowouts.

6 Tyre safety and chain fitting : for information on servicing conditions and, depending on the vehicle version, the use of chains → **297.**



For your safety, please respect the speed limit. When they need to be replaced, only tyres of

the same make, size, type and profile should be used on a single axle.

They must : either have a load capacity and speed rating at least equal to those of the original tyres, or conform to those recommended by an authorised dealer.

Failure to heed these instructions could endanger your safety and affect your vehicle's roadworthiness.

Risk of loss of control of the vehicle.

Tyre pressure kit

32788



The kit repairs tyres when tread **A** has been damaged by objects smaller than 4 mm. It cannot repair all types of puncture, such as cuts larger than 4 mm, or cuts in tyre sidewall **B**. Ensure also that the wheel rim is in good condition. Do not pull out the foreign body causing the puncture if it is still in the tyre.

TYRES



Do not attempt to use the inflation kit if the tyre has been damaged as a result of driving with a puncture.

You should therefore carefully check the condition of the tyre sidewalls before any operation. Driving with underinflated, flat or punctured tyres can be dangerous and may make the tyre impossible to repair.

This repair is temporary.

A tyre which has been punctured should always be inspected (and repaired, where possible) as soon as possible by a specialist.

When taking a tyre which has been repaired using this kit to be replaced, you must inform the specialist.

When driving, vibration may be felt due to the presence of the repair product injected into the tyre.



The kit is only approved for inflating the tyres of the vehicle originally equipped with the kit.

It must never be used to inflate the tyres of another vehicle, or any other inflatable object (rubber ring, rubber boat, etc.). Avoid spillage on skin when handling the repair product bottle. If droplets do leak out, rinse them off with plenty of water. Keep the repair kit away from children.

Do not dispose of the empty bottle in the countryside. Return it to your approved dealer or to a recycling organisation.

The bottle has a limited service life which is indicated on its label. Check the expiry date.

Contact an approved dealer to replace the inflation tube and repair product bottle.

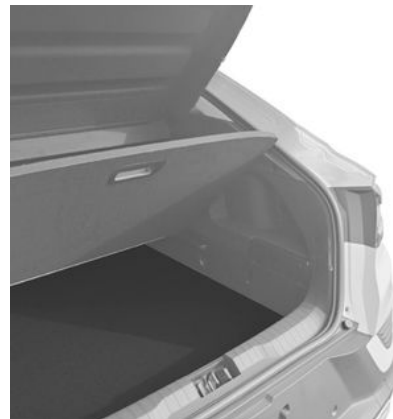

54264

6

Depending on the vehicle, in the event of a puncture, use the kit located in the boot or underneath the luggage compartment carpet or inside of the right hand cover in the boot.

Vehicle fitted with a tyre pressure loss warning system

In the event of under-inflation (punctures, under-inflation etc.), the  warning light appears on the instrument panel ➔ 159.

TYRES

47426

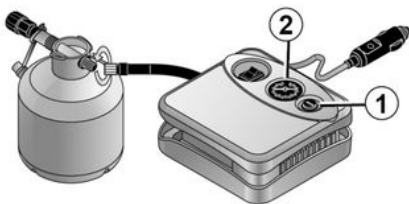

6

Engine running, handbrake applied :

- Disconnect any accessories previously connected to the vehicle's accessories sockets ;
- **refer to the information on the inflation kit compressor** located in the luggage compartment of the vehicle and follow the instructions ;
- inflate the tyre to the recommended pressure → 299 ;
- after a maximum of 15 minutes, stop inflating and read the pressure (on pressure gauge 2).

Note : while the bottle is emptying (approximately 30 seconds), the pressure gauge 2 will briefly indicate a pressure of 6 bar, then the pressure drops ;

- Adjust the pressure : to increase it, continue inflation with the kit. To reduce it, press the button 1.

If a minimum pressure of 1.8 bar is not reached after 15 minutes, repair is not possible ; do not drive the vehicle but contact an approved dealer.



Before using this kit, park the vehicle at a sufficient distance from traffic, switch on the hazard warning lights, apply the parking brake, ask all passengers to leave the vehicle and keep them away from traffic.



If the vehicle is parked on the hard shoulder, you must warn other road users of your vehicle's presence with a warning triangle or with other devices as per the legislation applying to the country you are in.

47426

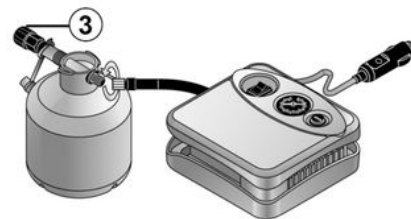

Once the tyre is correctly inflated, remove the kit : unscrew the inflation adapter slowly from the container 3 to prevent any product spatter and store the container in plastic packaging to prevent product leaks.

- Affix the driving recommendation label (located under the container) to the dashboard where the driver can see it.
- At the end of this initial inflation operation, air will still escape from the tyre. You must drive a short distance in order to seal the hole.
- Put the kit away.
- At the end of this initial inflation operation, air will still escape from the tyre. You must drive a short distance in order to seal the hole.

TYRES

- Start immediately and drive at a speed between 12 to 37 mph (20 to 60 km/h) in order to distribute the product evenly in the tyre ; after driving a distance of 2 miles (3 km), stop and check the pressure.
- If the pressure is higher than 1.3 bar but lower than the recommended pressure (refer to the label affixed to the edge of the driver's door), adjust it. Otherwise, contact an approved dealer : the tyre cannot be repaired.

Precautions when using the kit

The kit should not be operated for more than 15 consecutive minutes. The container must be replaced after the first use even if liquid remains inside.



Nothing should be placed around the driver's feet as such objects may slide under the pedals during sudden braking manoeuvres and obstruct their use.



Please be aware that a poorly tightened or missing valve cap can make the tyres less air-tight and may lead to pressure loss.

Always use valve caps identical to those fitted originally and tighten them fully.



Following repair with the kit, do not travel further than 120 miles (200 km). In addition, reduce your speed and under no circumstances exceed 48 mph (80 km/h). The sticker, which you must affix in a prominent position on the dashboard, reminds you of this. Depending on the country or local legislation, a tyre repaired with the inflation kit may need to be replaced.

Tools

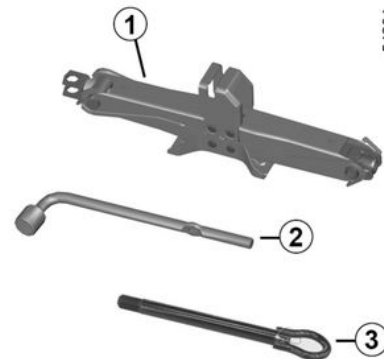
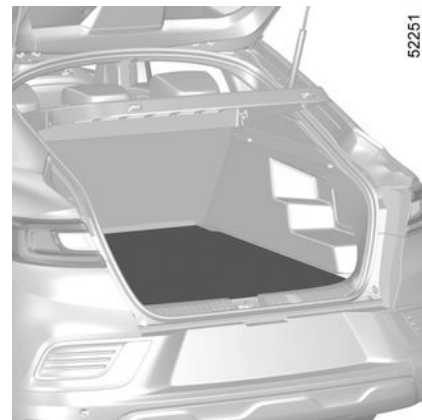

The tools included in the tool kit depending on the vehicle.

TYRES

After use, ensure the tools are correctly stored.



Do not leave the tools unsecured inside the vehicle as they may be projected during braking. After use, check that all the tools are correctly clipped into the tool kit, then position it correctly in its housing to reduce any risk of injury.

If bolts are supplied with the emergency spare wheel, you must use these bolts only for the emergency spare wheel.



For your safety, the use of a jack not recommended by the manufacturer is strictly prohibited.

prohibited.

The jack is specific to the vehicle and used to change the wheels.

Under no circumstances should it be used:

- on another vehicle ;
- to carry out a repair ;
- to access the underside of the vehicle.

Risk of injury.

Risk of damage to the vehicle.

Jack 1

Wrench 2

Tow eye 3

➔ 309

Puncture, emergency spare wheel

In case of puncture

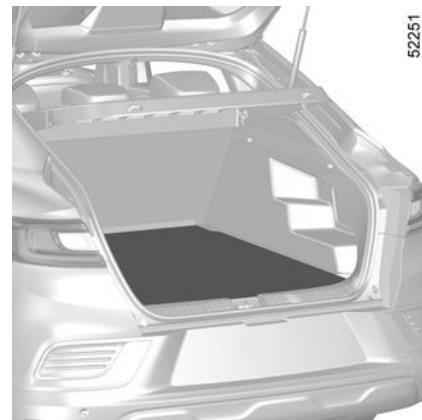

Depending on the vehicle, the following may be available :

- a tyre inflation kit located in the tray under the luggage compartment carpet or in the rear right-hand door storage compartment (depending on the vehicle).
- an emergency spare wheel or self-repairing tyres.

Vehicle fitted with a tyre pressure loss warning system

In the event of under-inflation (punctures, under-inflation etc.), the 

TYRES

warning light appears on the instrument panel → 159



If the emergency spare wheel has been stored for several years, have it checked by your

Dealer to ensure that it is safe to use.

Vehicle fitted with an emergency spare wheel that differs from the other wheels :

- Never fit more than one emergency spare wheel to the same vehicle.
- Replace the emergency spare wheel as soon as possible with a wheel identical to the original one.
- When this is fitted to the vehicle, which must only be a temporary measure, the driving speed must not exceed the speed indicated on the label on the wheel.
- Fitting an emergency spare wheel may alter the way the vehicle usually runs. Avoid sudden acceleration or deceleration and reduce your speed when cornering.

- If you need to use snow chains, fit the emergency spare wheel to the rear axle and check the tyre pressure.



If the vehicle is parked on the hard shoulder, you must warn other road users of your vehicle's presence with a warning triangle or with other devices as per the legislation applying to the country you are in.

TYRES

Emergency spare wheel

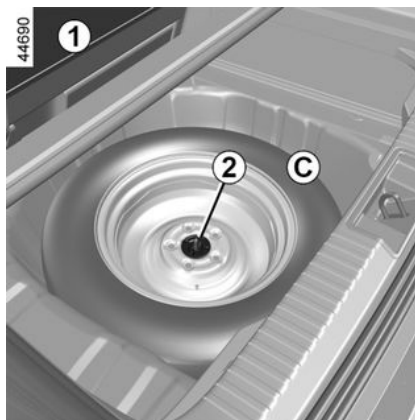
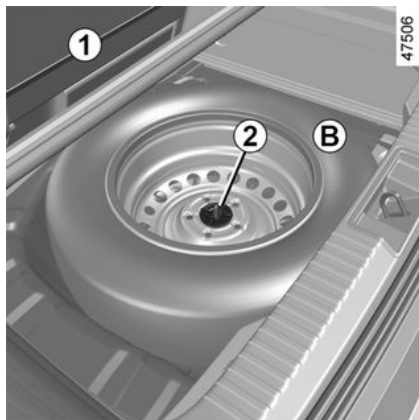

To get to it:

- open the boot;
- depending on the vehicle, lift up the movable floor and the luggage compartment mat **1**;
- unscrew the central mounting **2** in the centre of the emergency spare wheel;
- remove the emergency spare wheel (**B** or **C**, depending on the vehicle).

Note: in the absence of an emergency spare wheel or tyre inflation kit, do not load the bottom of the luggage compartment.

Depending on the vehicle, the tool block is located under or above the spare wheel, attached to the wall under the luggage compartment carpet.

Note: after fitting the emergency spare wheel, it is recommended that the punctured wheel is not stored under the luggage compartment carpet. Please put the wheel on the carpet and contact your approved dealer.



If the vehicle is parked on the hard shoulder, you must warn other road users of your vehicle's presence with a warning triangle or with other devices as per the legislation applying to the country you are in.

Changing a wheel

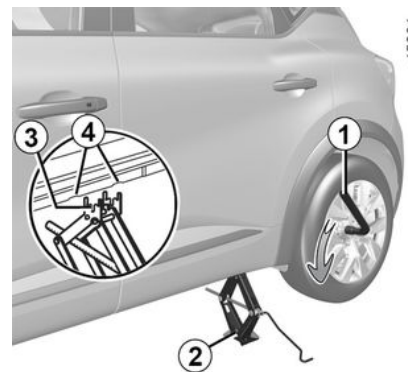

TYRES



Switch on the hazard warning lights. Keep the vehicle away from traffic and on a level surface where it will not slip.

Apply the parking brake and engage a gear (first or reverse, or P for automatic transmissions). Ask all the passengers to leave the vehicle and keep them away from traffic.

Vehicles equipped with a jack and wheelbrace

If necessary, remove the wheel trim. Use the wheelbrace **1** to slacken off the wheel bolts. Position it so as to be able to push from above. Place the jack **2** horizontally; the jack head **must** be lined up with the sill closest to the wheel concerned, between the two notches **4**.



If the vehicle is not equipped with a jack or wheelbrace, you can obtain these from your approved dealer.

Start cranking the jack by hand, positioning the jack support plate **3** in the slightly indented groove underneath the vehicle, located between the two notches **4**.

Continue to crank the jack so that the baseplate is correctly positioned (it should be underneath the vehicle and aligned with the jack head). Turn it a few times to lift the wheel off the ground.



If the vehicle is parked on the hard shoulder, you must warn other road users of your vehicle's presence with a warning triangle or with other devices as per the legislation applying to the country you are in.

Undo the bolts and take off the wheel.

Fit the emergency spare wheel on the central hub and turn it to locate the mounting holes in the wheel and the hub.

Tighten the bolts, checking that the wheel is correctly positioned on its hub.

Lower the jack.

With the wheel on the ground, tighten the bolts fully and have the tightness of the bolts checked and the emergency spare wheel pressure checked as soon as possible.



If you have a puncture, replace the wheel as soon as possible.

A tyre which has been punctured should always be inspected (and repaired, where possible) by a specialist.

Vehicle fitted with a tyre pressure loss warning system

In the event of under-inflation (punctures, under-inflation etc.), the  warning light appears on the instrument panel. → 159

TYRES



Do not leave the tools unsecured inside the vehicle as they may be projected during braking. After use, check that all the tools are correctly clipped into the tool kit, then position it correctly in its housing to reduce any risk of injury.

If bolts are supplied with the emergency spare wheel, you must use these bolts only for the emergency spare wheel.



For your safety, the use of a jack not recommended by the manufacturer is strictly prohibited.

The jack is specific to the vehicle and used to change the wheels.

Under no circumstances should it be used:

- on another vehicle ;
- to carry out a repair ;
- to access the underside of the vehicle.

Risk of injury.

Risk of damage to the vehicle.

BREAKDOWN RECOVERY

Towing: breakdown recovery

Before carrying out any towing, position the gearbox in neutral position (position N on vehicles equipped with an automatic gearbox), unlock the steering column then release the parking brake.

Steering column unlocking

With the card on you, press the engine start button for approximately **two seconds**.

Reposition the lever to neutral (position N for vehicles fitted with an automatic gearbox).

The steering column unlocks, the accessory functions are powered: you can use the vehicle's lights (direction indicators, brake lights, etc.). At night the vehicle must have its lights on.

Depending on the vehicle, once you have finished towing, press the engine start button twice (risk of running down the battery).

The speed specified by current legislation for towing must always be observed. If you are driving the towing vehicle, do not exceed the permissible towing weight for your vehicle.

→ 338.



ate.

When the ignition is off, the steering and braking assistance functions no longer operate.



Leave the card in the vehicle during towing. **Risk of the steering column locking.**

Towing a vehicle

Transport the vehicle on a trailer or tow it with the front wheels off the ground.

In exceptional circumstances, you may tow it with all four wheels on the ground, only in a forward gear, with the gearbox in neutral position N, over a maximum distance of 50 miles (80 km) and not exceeding a speed of 16 mph (25 km/h).



Leave the card in the vehicle during towing. **Risk of the steering column locking.**

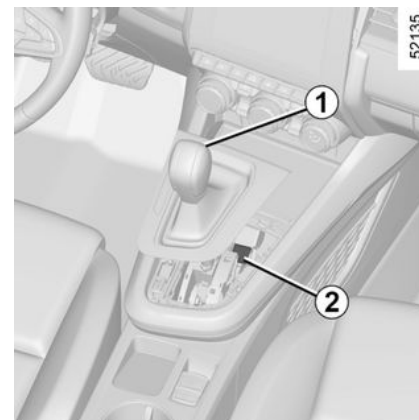

Automatic gearbox with manual lever

When setting off, if the lever is locked in position P even though you are pressing the brake pedal, the lever can be released manually in order to unlock the drive wheels.

To do this, unclip the base of the gaiter and press the **2** button while simultaneously pressing the **1** button on the lever to unlock the lever.

Contact an authorised dealer as soon as possible.

BREAKDOWN RECOVERY

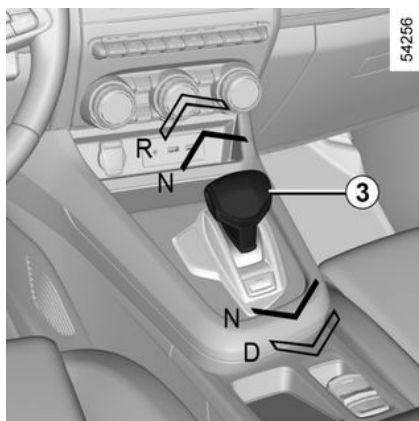

Automatic gearbox with electronic lever (e-shifter)

As position P is **automatically engaged** when the ignition is switched off, in some situations (e.g. when using some car washes) it may be necessary to engage position N.

With position P engaged and the ignition switched on (with the READY message on the instrument panel), shift the gear lever **3** a notch forwards or backwards. Wait approximately one minute then switch off the ignition by pressing the start button.

The next time the ignition is switched on, the automatic engagement of position P will be reactivat-

ed and it will be engaged in the situations previously described.

Access to towing points

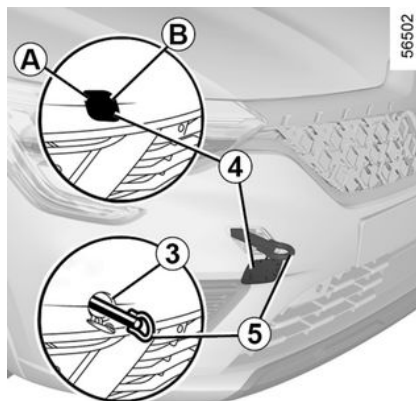

Only use the front 3 and rear 7 towing points (never use the driveshafts or any other part of the vehicle).

These towing points may only be used for pulling. They must never be used for lifting the vehicle directly or indirectly.



When the engine is stopped, steering and braking assistance are not operational.

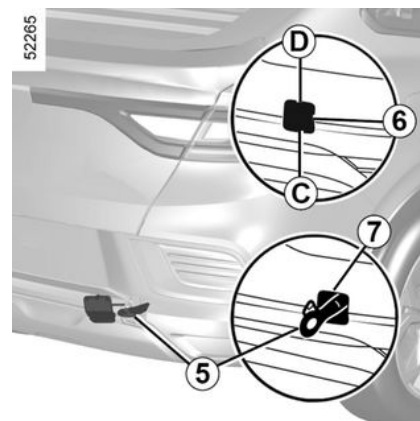

Front towing point

Press zone **A** and pull zone **B**. Use a driver or similar one to open flap **4**.

Rear towing point

Press zone **C** and pull zone **D**. Use a driver or similar one to open flap **6**.



Do not leave the tools unsecured inside the vehicle as they may come loose under braking.

Tighten the towing hitch 5 fully: first by hand until it stops, then finish by

BREAKDOWN RECOVERY

locking it with the wheel brace or a similar tool.

Only use the towing hitch **5** provided with the tools. ➔ **303**



Ensure that the towing eye is bolted correctly.

Risk of losing the towed object.



– Use a rigid towing bar. If a rope or cable is used (where the law allows this), the vehicle being towed must be able to brake.

- A vehicle must not be towed if it is not fit to be driven.
- Avoid accelerating or braking suddenly when towing, as this may result in damage being caused to the vehicle.
- In all cases, it is advisable not to exceed **15.5 mph (25 km/h)**.

Battery: breakdown recovery

To avoid all risk of sparks :

- Ensure that any power consumers (courtesy lights, etc.) are switched off before disconnecting or reconnecting a battery ;
- when charging, stop the charger before connecting or disconnecting the battery ;
- do not place metal objects on the battery as this could create a short circuit between the terminals ;
- always wait at least five minutes after the engine has been switched off before disconnecting a battery ;
- make sure that you reconnect the battery terminals after refitting.



Before carrying out any action in the engine compartment, you must switch off the ignition. ➔ **128**

Connecting a battery charger

The battery charger must be compatible with a battery with nominal voltage of 12 volts.

Do not disconnect the battery when the engine is running. **Follow the in-**

structions given by the manufacturer of the battery charger you are using.



Special procedures may be required to charge some batteries. Contact your approved dealer.

Avoid all risk of sparks which may cause an immediate explosion, and charge the battery in a well ventilated area.

Risk of serious injury.

BREAKDOWN RECOVERY



Handle the battery with care as it contains sulphuric acid, which must not come into contact with eyes or skin. If it does, wash the affected area with plenty of cold water. If necessary, consult a doctor. Keep naked flames, red hot objects and sparks away from the battery components as there is a **risk of explosion**.

Please note when working close to the engine that it may be hot. In addition, the engine cooling fan may start at any moment.

The  warning light in the engine compartment reminds you of this.

Risk of injury.

Starting the vehicle using the battery from another vehicle

If you have to use the battery from another vehicle to start, obtain suitable jump leads (with a large cross section) from an approved dealer or, if you already have jump leads, en-

sure that they are in perfect condition.

The two batteries must have an identical nominal voltage : 12 volts.

The battery supplying the current should have a capacity (amp-hours, Ah) which is at least the same as that of the discharged battery.

Ensure that there is no risk of contact between the two vehicles (risk of short circuiting when the positive terminals are connected) and that the discharged battery is properly connected. Switch off your vehicle ignition.

Depending on the vehicle, unclip the battery cover and raise the cover **A** of the **terminal 1 (+)**.

Connect the positive cable **B** to the **terminal 1 (+)** then to the **terminal 4 (+)** of the battery supplying the current.

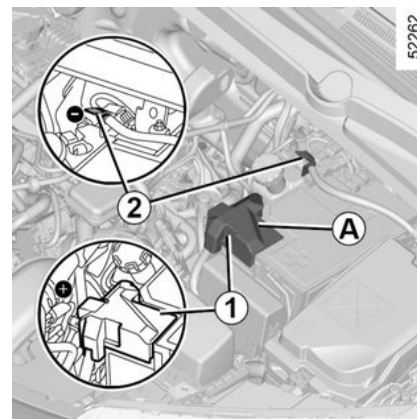

Connect the negative cable **C** to the **terminal 3 (-)** of the battery supplying the current and then to the **terminal 2 (-)** of the discharged battery.

Start the engine of the vehicle supplying the current and run it at an intermediate engine speed.

BREAKDOWN RECOVERY



Check that there is no contact between leads **B** and **C** and that the positive lead **B** is not touching any metal parts on the vehicle supplying the current.

Risk of injury and/or damage to the vehicle.

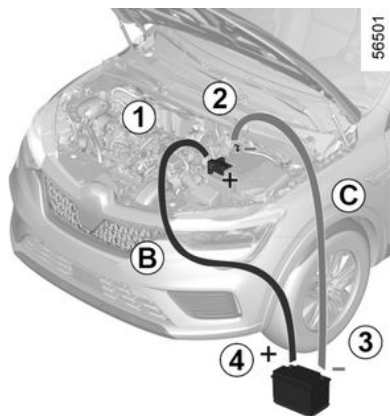

If your vehicle's engine does not start immediately, switch off the ignition and wait a few seconds before repeating the operation.

With the engine running, disconnect the cables **B** and **C** in reverse order (**2 - 3 - 4 - 1**).

Starting the vehicle using the battery from another vehicle for E-Tech full hybrid version

If the 12V battery charge level is too low, it is possible to use the battery of another vehicle to re-activate and operate the hybrid system. ➔ **128**

As the battery cannot be directly accessed, it is necessary to use the remote terminals located in the engine compartment.

Obtain suitable leads (large cross-section) from an approved dealer. If you already have jump leads, ensure that they are in good condition.

The two batteries must have an identical nominal voltage : "12 V".

The battery supplying the current should have a capacity (amp-hours, Ah) which is at least the same as that of the discharged battery.

Ensure that there is no risk of contact between the two vehicles (risk of short circuiting when the positive terminals are connected) and that the discharged battery is properly connected. Switch off your vehicle ignition.

Start the engine of the vehicle supplying the current and run it at a moderate speed.



Do not use your hybrid vehicle to restart a "12 V" battery in another vehicle.

The electrical power in the 12V battery of a hybrid vehicle is not sufficient for this operation. Risk of damage to the vehicle.



Please note when working close to the engine that it may be hot. The engine cooling fan may also start at any mo-

ment. The  label in the engine compartment reminds you of this.

Risk of injury.



Do not carry out any work under the bonnet while the vehicle is charging or while the ignition is switched on. ➔ **128**

BREAKDOWN RECOVERY

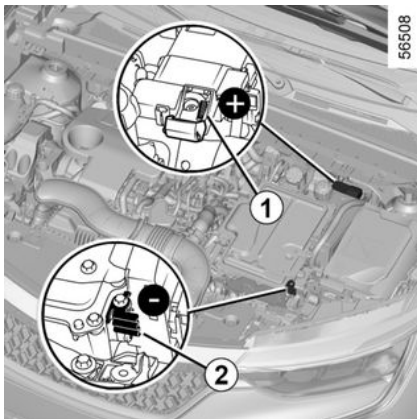

Remote terminals

Use the **terminal 1 (+)** and the **terminal 2 (-)** in the engine compartment.



It is forbidden to disconnect the positive cable in the engine compartment.

Risk of the engine starting inadvertently.

Risk of burns by projection of sparks.

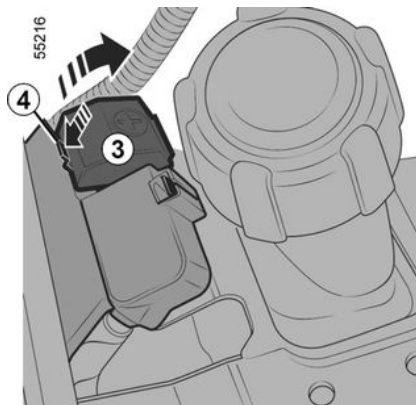

Note: open the cover **3** of the terminal **1 (+)** by pressing the button **4** as indicated by the arrow.

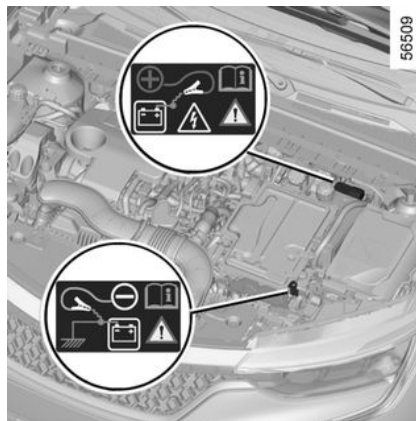

Check that there is no contact between leads **A** and **B** and that the positive lead **A** is not touching any metal parts on the vehicle supplying the current.
Risk of injury and/or damage to the vehicle.

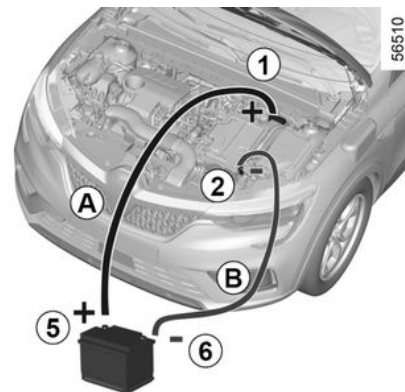

Attach the positive cable **A** to the **terminal 1 (+)**, then to the **terminal 5 (+)** of the battery supplying the current.

Connect the negative cable **B** to the **terminal 6 (-)** of the battery supply-

BREAKDOWN RECOVERY

ing the current and then to the terminal 2 (-).

Press the brake pedal and the Start button or, depending on the vehicle, turn on the ignition key. As soon as the ignition is switched on, disconnect the **A** and **B** cables in the reverse order (**2-6-5-1**).

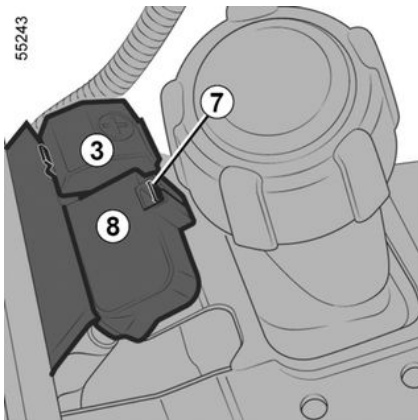

After each operation of the cover **3**, check the terminal block cover **8** on its tab **7**.

HEADLIGHTS, LIGHTS: REPLACING BULBS

Exterior lighting: replacing bulbs

Headlights: changing bulbs

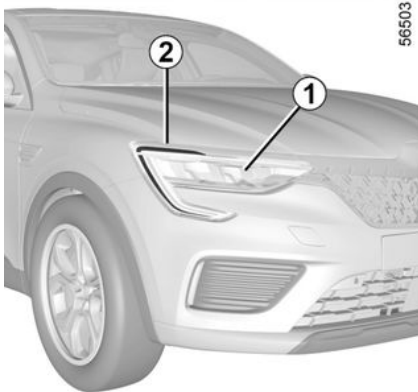

56503



Any operation on (or modification to) the electrical system must be performed by an approved dealer since an incorrect connection might damage the electrical equipment (harness, components and in particular the alternator). In addition, your Dealer has all the parts required for fitting these units.

Rear lights and side lights: changing bulbs

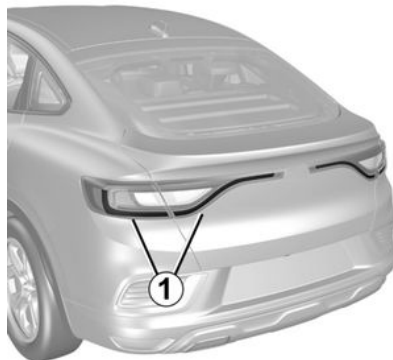

52276

LED side light 1

Consult an approved dealer.

Bulb brake light 2, Direction indicator 3

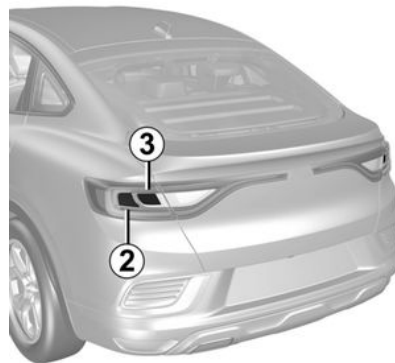

56727

Your vehicle is fitted with lights with LED, contact an Approved Dealer for replacement.

Direction indicators/dipped beam headlights/LED main beam headlights 1

Please see an authorised dealer.

LED daytime running lights/side lights 2

Please see an authorised dealer.

HEADLIGHTS, LIGHTS: REPLACING BULBS

52132

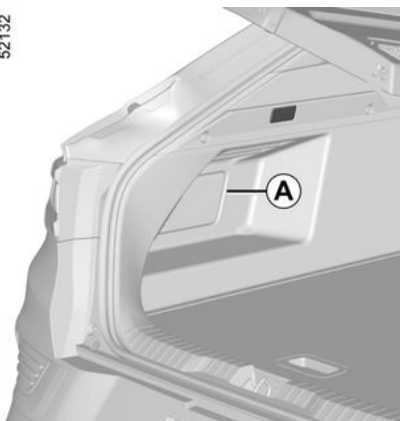

- open the tailgate.
- remove the cover **A** (the side where the bulb to be replaced).
- unscrew the nut and clips to release the light assembly from the outside of the vehicle by pulling towards the rear.

56730

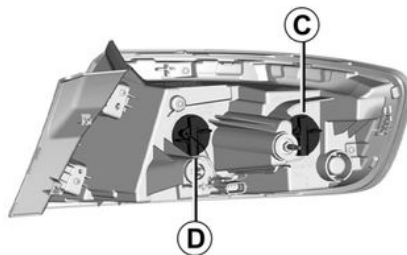

Remove the bulb holder **B** (Direction indicator **3**) or **C** (Bulb brake light **2**) by unscrewing it a quarter of a turn, then replace the bulb.

Brake light bulb type: P21W

Direction indicator light bulb type: PY21W

To refit, proceed in the reverse order, taking care not to damage the wiring.



The bulbs are under pressure and can break when replaced.
Risk of injury.

Reverse light 4

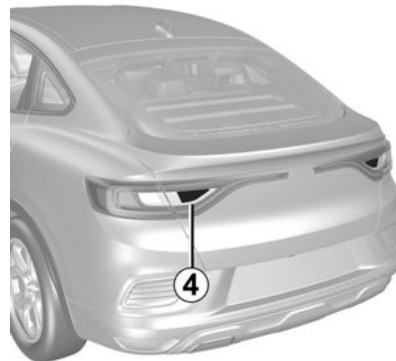

52277

6

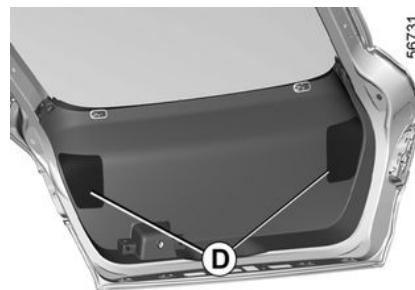

56731

HEADLIGHTS, LIGHTS: REPLACING BULBS

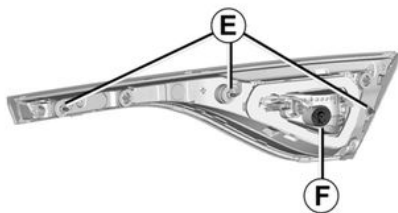

56729

LED high-level brake light 5

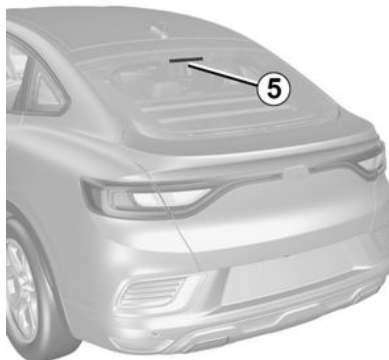

52278

Consult an approved dealer.

LED number plate lights 6

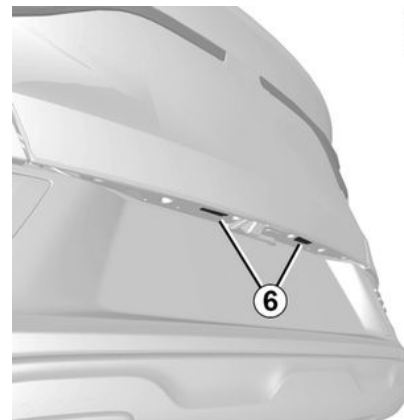

52247

Consult an approved dealer.

6

- open the tailgate.
- remove the cover **D** (the side where the bulb to be replaced).
- unscrew the nut **E** and clips to release the light assembly from the outside of the vehicle by pulling towards the rear.
- Remove the bulb holder **F** by unscrewing it a quarter of a turn, then replace the bulb.

HEADLIGHTS, LIGHTS: REPLACING BULBS

LED side repeaters 7



Consult an approved dealer.

Interior lighting: changing bulbs

Bulb/LED Courtesy light 1

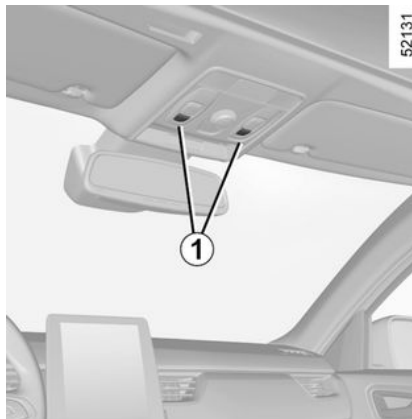

Consult an approved dealer.

Courtesy light A



Depending on the vehicle, there are two types of courtesy light **A** or **B**.

In case of **A** type,

- Unclip the lens (using a flat-blade screwdriver or similar);
- remove the bulb concerned.

Bulb type : W5W.



The bulbs are under pressure and can break when replaced.

Risk of injury.

HEADLIGHTS, LIGHTS: REPLACING BULBS

LED reading lights B

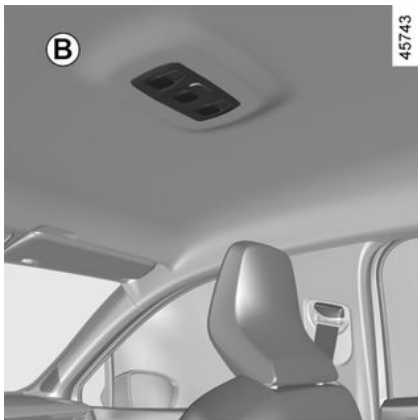

Consult an authorised dealer.

Luggage compartment light

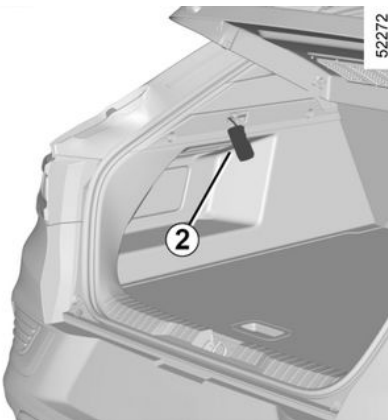

- Unclip the light **2** by pressing the tab on its left side (using a flat-bladed screwdriver or similar) ;
- remove the bulb concerned.

Bulb type : W5W.

Glovebox light

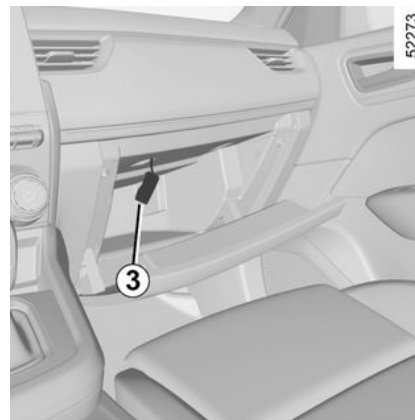

- Unclip the light **3** by pressing the tab on its left side (using a flat-bladed screwdriver or similar) ;
- remove the bulb concerned.

Bulb type : W5W.

HEADLIGHTS, LIGHTS: REPLACING BULBS

Courtesy mirror lights 4



Please consult an authorised dealer.

Ambient lighting

Please consult an authorised dealer.

WIPER BLADES: REPLACEMENT

Replacing the windscreen wiper blades 2



To replace the wipers, first put them in the service position **B**.

Engine running or ignition on ;

- set the stalk **1** to position **A** twice in succession (single sweep) : the wiper blades will stop in the service position **B** away from the bonnet ;
- lift the wiper arm **3** ;
- lower the **4** tab then remove the blade **2**.

To refit

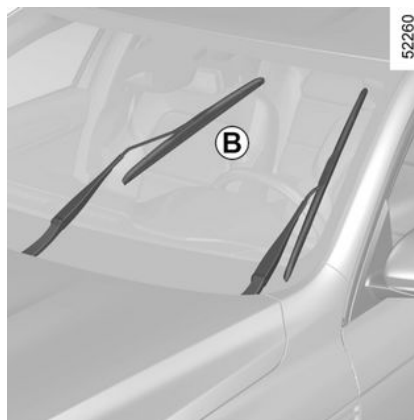

To refit the wiper blade **2**, insert it in its housing in the arm **3**, then clip it until you hear a click. Make sure that the blade is correctly locked in position.

To return the blades to lowered position, make sure that the blades are folded down onto the windscreen then set the **1** stalk to position **A** (single sweep) : the windscreen wiper blades will fold into the bonnet when the ignition is switched on.

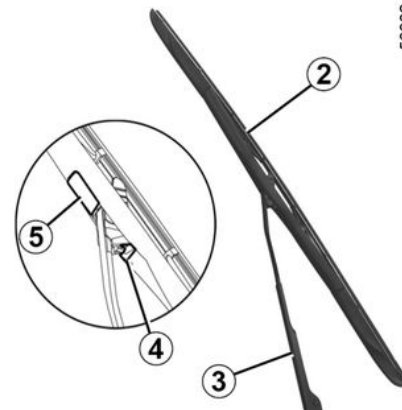

i Check the condition of the wiper blades. You are responsible for their service life :

- clean the blades, windscreen and rear screen regularly with soapy water ;
- do not use them when the windscreen or rear screen are dry ;
- free them from the windscreen when they have not been used for a long time.

WIPER BLADES: REPLACEMENT



Check the condition of the wiper blades.

- clean the blades, windscreen regularly with soapy water ;
- do not use them when the windscreen is dry ;
- free them from the windscreen when they have not been used for a long time.



- In frosty weather, make sure that the wiper blades are not stuck by ice (to avoid the risk of the motor overheating).

- Check the condition of the wiper blades. Replace the wiper blades as soon as they begin to lose efficiency (approximately once a year).

When changing the blade, when it has been removed, do not let the wiper arm fall against the window : risk of breaking the window.

FUSES

Fuse boxes

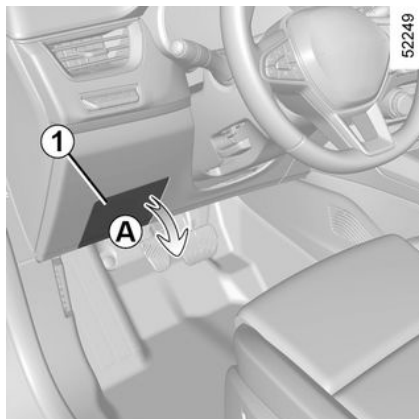

If any electrical component does not work, check the condition of the fuses.

Passenger compartment fuses A

Unclip the access flap 1.

i To comply with current legislation, or as a precaution, you can obtain an emergency kit from your approved dealer containing a set of spare bulbs and fuses.

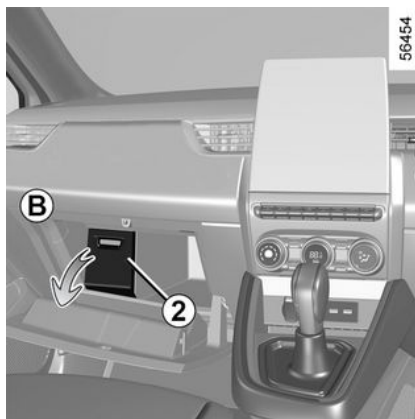

Fuses located in the passenger compartment behind a flap in the B glovebox

Unclip the access flap 2.



Check the fuse in question and **replace it, if necessary, by a fuse of the same rating.**

If a fuse is fitted with too high a rating, it may cause the electrical circuit to overheat (risk of fire) in the event of an item of equipment using an excessive amount of current.

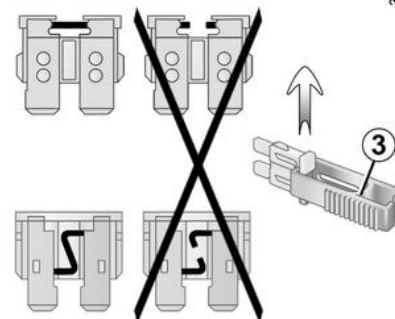

Tweezers 3

Remove the fuse using the tweezers 3 on the back of the flap.

To remove the fuse from the tweezers, slide the fuse to the side.









It is not advisable to use the free fuse locations.

Note: Tweezers 3 is located on the back of flap 1.

Allocation of fuses

(the presence of certain fuse depends on the vehicle equipment level)

FUSES

Symbol	Allocation
	Windscreen washer
	Multimedia accessories socket, multimedia screen
	Front and rear second row accessories socket
	Horn
	Towbar socket
	Heated rear view mirrors
	Brake lights, passenger compartment central unit
	Passenger compartment centre unit, rear fog light
	Direction indicator lights, hazard warning lights, high level brake lights



Use the fuse allocation label in the storage compartment to identify the

fuses.

Certain fuses should only be replaced by a qualified professional. These fuses are not listed on the label.

Only change the fuses represented on the label.

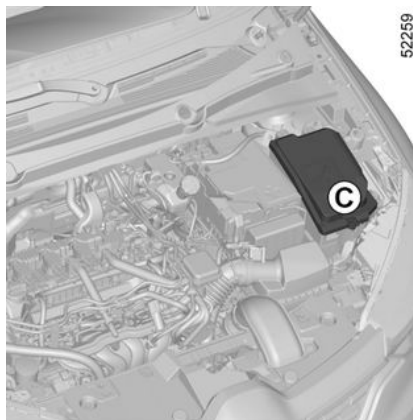

52259

Fuses in engine compartment C

Some functions are protected by fuses located in the engine compartment (unit C).

However, because of their reduced accessibility, **we advise you to have your fuses replaced by an approved Dealer.**



Please note when working close to the engine that it may be hot. In addition, the engine cooling fan may start at

any moment. The  warning light in the engine compartment reminds you of this.

Risk of injury.



Before carrying out any action in the engine compartment, you must switch off the ignition. ➔ 128

INSTALLATION AND USE OF ACCESSORIES



Electrical and electronic accessories

Before installing this type of accessory (particularly for transmitters/receivers : frequency bandwidth, power level, position of the aerial, etc.), make sure it is compatible with your vehicle. You can get advice from an authorised dealer.

Before connecting an accessory to a socket, please ensure that you do not exceed the maximum power authorised for the socket → 271 → 261. **Fire hazard.**

Any work on the vehicle's electrical and/or electronic circuit must only be carried out by a qualified professional. Any incorrect connection and/or installation of electrical/electronic accessories not approved by the manufacturer may cause :

- damage to the electrical and/or electronic equipment ;
- damage to the components connected to it ;
- the collection and use of vehicle data ;
- an invasion of privacy (modification, deletion or unwarranted access to personal data) ;
- cancellation of the authorisation for entry into service.

Risk of serious accidents. Risk of invasion of privacy.

If you have electrical equipment fitted in future, make sure that you are notified of the rating and position of the corresponding fuse.

Using the diagnostic socket

The use of electronic accessories on the diagnostic socket may cause serious disturbance to the vehicle's electronic systems and/or cause invasion of privacy (modification, deletion or unwarranted access to personal data). For your safety we recommend that you use only electronic accessories approved by the manufacturer, consult an Approved Dealer. **Serious accident risk. Risk of invasion of privacy.**

Fitting aftermarket accessories

If you wish to install accessories on the vehicle : please contact an authorised dealer. Also, to ensure the correct operation of your vehicle, and to avoid any risk to your safety, we recommend that you use only accessories specifically designed for your vehicle, which are the only accessories for which the manufacturer will provide a warranty.

If you are using an anti-theft device, only attach it to the brake pedal.

Obstructions to the driver

INSTALLATION AND USE OF ACCESSORIES

On the driver's side, only use mats suitable for the vehicle, attached with the pre-fitted components, and check the fitting regularly. Do not lay one mat on top of another. **There is a risk of wedging the pedals.**

OPERATING FAULTS

The following advice will enable you to carry out quick, temporary repairs. For safety reasons you should always contact an approved dealer as soon as possible.

Using the card	POSSIBLE CAUSES	WHAT TO DO
The card does not lock or unlock the doors.	Card battery is flat.	Replace the battery. You will still be able to lock/unlock and start your vehicle. → 39 and → 128
	Use of appliances operating on the same frequency as the card (mobile phone, etc.).	Stop using the devices or use the key provided. → 39
	Vehicle located in a high electromagnetic radiation zone.	Use the key that is built into the card. → 39
	Vehicle battery flat.	
	The message "Place card on zone + START" appears on the instrument panel.	Place the card in the placement area → 128 then press the START button.
	The vehicle is started.	With the engine running, the card's locking/unlocking device is blocked. Turn off the ignition.
	Desynchronisation of the card.	Unlock the driver's door by inserting the key integrated in the card into the door lock → 39, then place the card in the placement area → 128 and press the START button to synchronise the card.

The starter is activated	POSSIBLE CAUSES	ACTION REQUIRED
The instrument panel indicator lights are weak or fail to light up and the starter does not turn.	Battery terminals not tight, battery terminals disconnected or oxidised.	Retighten or reconnect the terminals, or clean them if they are oxidised.
	Discharged battery or not operational.	Connect another battery to the faulty battery. → 311 or replace the battery if necessary.

OPERATING FAULTS

The starter is activated	POSSIBLE CAUSES	ACTION REQUIRED
	Faulty circuit.	Do not push the vehicle if the steering column is locked. Consult an approved dealer.
The engine will not start.	Starting conditions are not fulfilled. The "hands-free" card does not work.	➔ 128. Place the card in the recess provided for this purpose on the centre console ➔ 128.
With the vehicle stationary, engine cold, the engine's idle speed is high.	Petrol version, this is not necessarily a fault. This may be caused by the increase in the engine temperature.	The engine's idle speed should decrease after about one minute. Otherwise, this may be caused by another fault. Call an approved Dealer.
The engine cannot be switched off.	Card not detected. Electronic fault.	Place the card in the recess provided for this purpose on the centre console. Press and hold the start button. Press the start button 3 times quickly or press and hold.
The steering column remains locked.	Steering wheel locked. Faulty electrical circuit.	Move the steering wheel while pressing the engine start button . Consult an approved dealer.

On the road	POSSIBLE CAUSES	WHAT TO DO
Vibrations.	Tyres not inflated to correct pressures, incorrectly balanced or damaged.	Check the tyre pressures : if this is not the problem, have them checked by an approved Dealer.
White smoke from the exhaust.	Petrol version, this is not necessarily a fault. Depending on the climate conditions (cold, humid-	Reduce the engine speed and avoid sudden acceleration to gradually make the smoke disappear. Other-

OPERATING FAULTS

On the road	POSSIBLE CAUSES	WHAT TO DO
	ity etc.), smoke may be produced under hard vehicle acceleration.	wise, this may be caused by another fault. Consult an approved dealer.
Smoke under the bonnet.	Short-circuit or cooling system leak.	Stop, switch off the ignition, stand away from the vehicle and contact an approved dealer.
The oil pressure warning light comes on :		
while cornering or braking.	The level is too low.	Top up the engine oil → 281.
is slow to go out or remains lit up under acceleration.	Loss of oil pressure.	Stop the vehicle and contact an approved Dealer.

On the road	POSSIBLE CAUSES	WHAT TO DO
Steering becomes heavy.	Assistance overheating.	Drive carefully at reduced speed, be aware of the level of force in the steering wheel needed to turn the wheels.
	Fault with the electric assistance motor.	Consult an authorised dealer.
	Fault in the assistance system.	
The engine is overheating. The coolant temperature indicator is in the warning zone and warning light STOP comes on.	Engine cooling fan not working.	Stop the vehicle, switch off the engine and contact an approved dealer.

OPERATING FAULTS

On the road	POSSIBLE CAUSES	WHAT TO DO
	Coolant leaks.	Check the coolant reservoir : it should contain fluid. If there is no coolant, consult an authorised dealer as soon as possible.
Coolant boiling in the coolant reservoir.	Mechanical fault : damaged cylinder head gasket.	Stop the engine. Contact an approved dealer.



Radiator : if there is a significant lack of coolant, remember that it must never be topped up using cold coolant while the engine is very warm. After any procedure on the vehicle which has involved even partial draining of the cooling system, it must be refilled with a new mixture prepared in the correct proportions. Reminder : only products approved by our Technical Department may be used for this purpose.

6

Electrical equipment	POSSIBLE CAUSES	WHAT TO DO
The wipers do not work.	Wiper blades stuck.	Free the blades before using the wipers.
	Faulty electrical circuit.	Consult an approved dealer.
	Fuse damaged.	Replace the fuse or have it replaced → 324.
The wiper does not stop.	Faulty electrical controls.	Consult an approved dealer.
Direction indicators flashing more quickly.	Blown rear bulb.	→ 316.
The direction indicators do not work.	Faulty electrical circuit or control.	Consult an approved dealer.
	Fuse damaged.	Replace the fuse or have it replaced → 324.

OPERATING FAULTS

Electrical equipment	POSSIBLE CAUSES	WHAT TO DO
The lights do not come on or go off.	Faulty electrical circuit or control.	Consult an approved dealer.
	Fuse damaged.	Replace the fuse or have it replaced → 324.

Electrical equipment	POSSIBLE CAUSES	WHAT TO DO
Traces of condensation in the headlights or rear lights.	Traces of condensation may be a natural phenomenon caused by variations in temperature and humidity. In this case, the traces will disappear slowly once the lights are switched on.	
The front seat belt reminder light comes on when the seat belts are fastened.	An object is stuck between the floor and the seat and is disrupting the operation of the sensor.	Remove all objects from underneath the front seats.

6

INFORMATION ABOUT THE VEHICLE

Vehicle identification plates

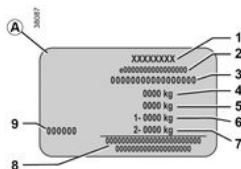
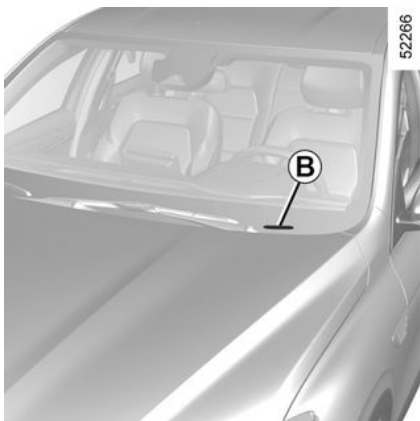
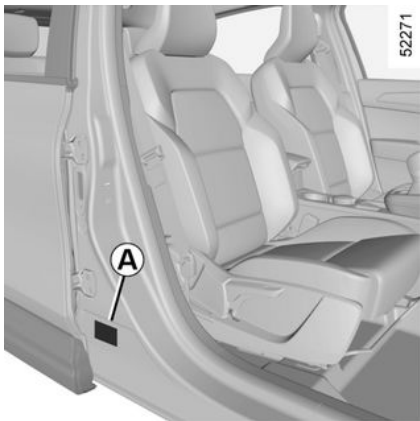

The information shown on the vehicle identification plate should be quoted on all correspondence or orders.

The presence and location of the information depends on the vehicle.

Vehicle identification plate A

1 Manufacturer name

2 EC design number or approval number

3 Identification number

Depending on the vehicle, this information is also given on marking B.

4 MMAC (Maximum authorised Mass)

5 MTR (Gross Train Weight : vehicle fully loaded, with trailer)

6 MMTA (Maximum Permissible Weight) front axle

7 MMTA rear axle

8 Reserved for related or additional entries

9 Paint reference (colour code)

Technical information for the emergency services

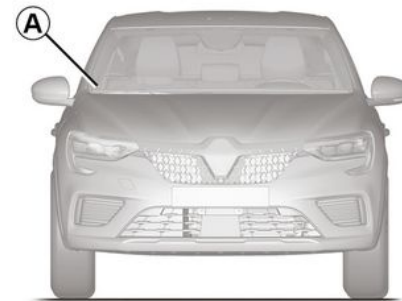

The QR Code on the A label allows emergency workers using a tablet or smartphone to immediately access the technical information useful for working on the vehicle in the event of an accident

Ensure that the A label is always visible and present on the windscreen as well as the rear screen

Any modification or damage would prevent access to the information

INFORMATION ABOUT THE VEHICLE

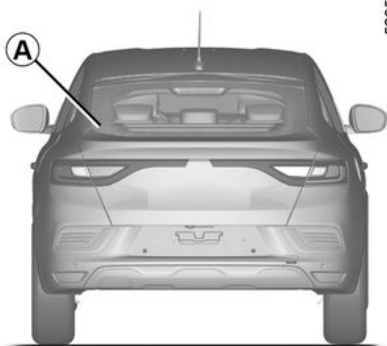

Engine identification, engine specifications

Engine identification plates

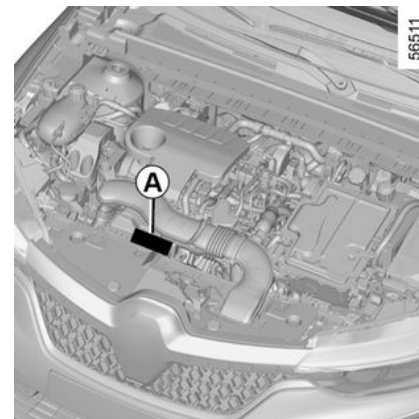
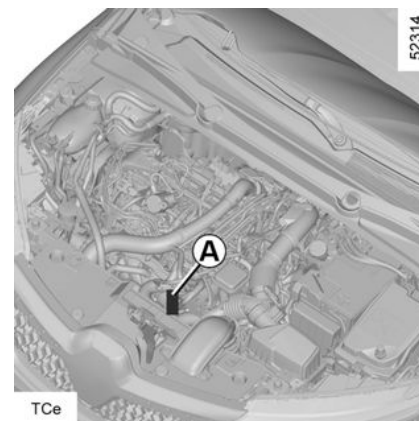
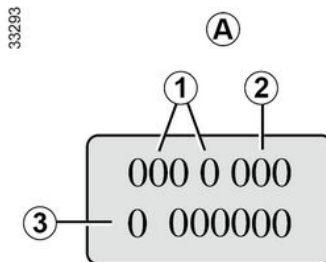



Please quote the information on the engine plate or label A in all correspondence or orders.

(Location varies depending on engine)

- 1 Engine type
- 2 Engine suffix
- 3 Engine number

INFORMATION ABOUT THE VEHICLE

Engine specifications

Versions	TCe 260	E-TECH hybrid
Engine type (see engine plate)	H5H	H4M
Cubic capacity (cc)	1,332	1598
Type of fuel Octane rating	Petrol You must use unleaded petrol with the octane rating stated on the label inside the fuel filler flap. ➔ 124	
Spark plugs	Only use the spark plugs specified for your vehicle's engine. The type should be marked on a label affixed inside the engine compartment. If it is not then contact an approved Dealer. Fitting spark plugs other than those specified may damage the engine.	
Fuel types that meet European standards and are compatible with the engines of vehicles sold in Europe (in any other case, contact an Approved Dealer).		Unleaded petrol compliant with standard EN 228 contains up to 5 % ethanol in volume.
		Unleaded petrol compliant with standard EN 228 contains up to 10 % ethanol in volume.

INFORMATION ABOUT THE VEHICLE

Dimensions (in metres)

56485

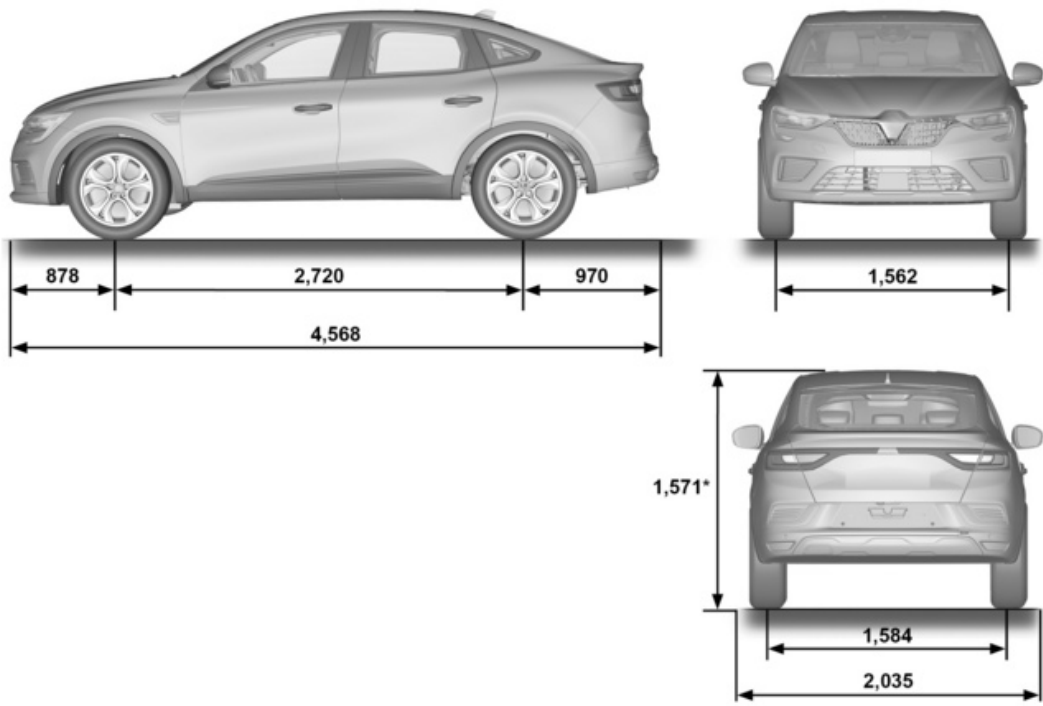

7

INFORMATION ABOUT THE VEHICLE

* unladen

INFORMATION ABOUT THE VEHICLE

Weights (in kg)

<p>The weights indicated for a basic vehicle without options : they vary depending on your vehicle's equipment. Consult your approved Dealer.</p>	
<p>Maximum Authorised Mass (MMAC) Maximum Permissible Weight (MMTA) Gross Train Weight (MTR)</p>	<p>Weights indicated on the vehicle identification plate → 333</p>
<p>Braked Trailer Weight*</p>	<p>found by calculating : MTR - MMAC for thermal vehicles</p>
	<p>760 kg for E-Tech full hybrid vehicles</p>
<p>Unbraked Trailer Weight*</p>	<p>705 kg for thermal vehicles</p>
	<p>750 kg for E-Tech full hybrid vehicles</p>
<p>Permissible nose weight*</p>	<p>75 kg</p>
<p>Maximum permissible load on roof</p>	<p>80 kg (including carrying device)</p>
<p>* Towing weight (towing a caravan, boat, etc.)</p> <p>Towing is prohibited when the MTR - MMAC calculation is equal to zero, or when the MTR is equal to zero (or is not listed) on the identification plate.</p> <ul style="list-style-type: none"> - It is important to comply with the towing weights, governed by local legislation in each country and, in particular, laid down in the Road Traffic Regulations. Contact an approved Dealer about any towing equipment. - When towing, under no circumstances may the total train weight (vehicle + trailer) be exceeded. However the following is permitted : <ul style="list-style-type: none"> - rear axle MMTA exceeded by no more than 15 %, - maximum MMAC exceeded by no more than 10 % or 100 kg (whichever is reached first). <p>In either case, the maximum speed of the vehicle and trailer must not exceed 60 mph (100 km/h) and the tyre pressures must be increased by 0.2 bar (3 PSI).</p> <ul style="list-style-type: none"> - The engine output and climbing capability are reduced with altitude. We recommend that the maximum load be reduced by 10 % at an altitude of 1,000 metres and by an additional 10 % for each 1,000 metres thereafter. 	

REPLACEMENT PARTS AND REPAIRS

Original parts are based on very stringent specifications and are subjected to specific tests. Therefore, they are of at least the same level of quality as the parts fitted originally.

If you always fit genuine replacement parts to your vehicle, you will ensure that it performs well. Furthermore, repairs carried out in the approved dealer network with original parts are guaranteed according to the conditions stated on the back of the repair order.

SERVICE SHEETS

VIN:

Date:	Miles (km):	Invoice number:	Comments/miscellaneous
Type of operation:		Stamp	
Service <input type="checkbox"/>			
..... <input type="checkbox"/>			
Anticorrosion check:			
OK <input type="checkbox"/> Not OK* <input type="checkbox"/>			
Date:	Miles (km):	Invoice number:	Comments/miscellaneous
Type of operation:		Stamp	
Service <input type="checkbox"/>			
..... <input type="checkbox"/>			
Anticorrosion check:			
OK <input type="checkbox"/> Not OK* <input type="checkbox"/>			
Date:	Miles (km):	Invoice number:	Comments/miscellaneous
Type of operation:		Stamp	
Service <input type="checkbox"/>			
..... <input type="checkbox"/>			
Anticorrosion check:			
OK <input type="checkbox"/> Not OK* <input type="checkbox"/>			

* See specific page

SERVICE SHEETS

VIN:

Date:	Miles (km):	Invoice number:	Comments/miscellaneous
Type of operation: Service <input type="checkbox"/> <input type="checkbox"/>		Stamp	
Anticorrosion check: OK <input type="checkbox"/> Not OK* <input type="checkbox"/>			
Date:	Miles (km):	Invoice number:	Comments/miscellaneous
Type of operation: Service <input type="checkbox"/> <input type="checkbox"/>		Stamp	
Anticorrosion check: OK <input type="checkbox"/> Not OK* <input type="checkbox"/>			
Date:	Miles (km):	Invoice number:	Comments/miscellaneous
Type of operation: Service <input type="checkbox"/> <input type="checkbox"/>		Stamp	
Anticorrosion check: OK <input type="checkbox"/> Not OK* <input type="checkbox"/>			

* See specific page

SERVICE SHEETS

VIN:

Date:	Miles (km):	Invoice number:	Comments/miscellaneous
Type of operation:		Stamp	
Service <input type="checkbox"/>			
..... <input type="checkbox"/>			
Anticorrosion check:			
OK <input type="checkbox"/> Not OK* <input type="checkbox"/>			
Date:	Miles (km):	Invoice number:	Comments/miscellaneous
Type of operation:		Stamp	
Service <input type="checkbox"/>			
..... <input type="checkbox"/>			
Anticorrosion check:			
OK <input type="checkbox"/> Not OK* <input type="checkbox"/>			
Date:	Miles (km):	Invoice number:	Comments/miscellaneous
Type of operation:		Stamp	
Service <input type="checkbox"/>			
..... <input type="checkbox"/>			
Anticorrosion check:			
OK <input type="checkbox"/> Not OK* <input type="checkbox"/>			

* See specific page

7

SERVICE SHEETS

VIN:

Date:	Miles (km):	Invoice number:	Comments/miscellaneous
Type of operation:		Stamp	
Service <input type="checkbox"/>			
..... <input type="checkbox"/>			
Anticorrosion check:			
OK <input type="checkbox"/> Not OK* <input type="checkbox"/>			
Date:	Miles (km):	Invoice number:	Comments/miscellaneous
Type of operation:		Stamp	
Service <input type="checkbox"/>			
..... <input type="checkbox"/>			
Anticorrosion check:			
OK <input type="checkbox"/> Not OK* <input type="checkbox"/>			
Date:	Miles (km):	Invoice number:	Comments/miscellaneous
Type of operation:		Stamp	
Service <input type="checkbox"/>			
..... <input type="checkbox"/>			
Anticorrosion check:			
OK <input type="checkbox"/> Not OK* <input type="checkbox"/>			

* See specific page

SERVICE SHEETS

VIN:

Date:	Miles (km):	Invoice number:	Comments/miscellaneous
Type of operation:		Stamp	
Service <input type="checkbox"/>			
..... <input type="checkbox"/>			
Anticorrosion check:			
OK <input type="checkbox"/> Not OK* <input type="checkbox"/>			
Date:	Miles (km):	Invoice number:	Comments/miscellaneous
Type of operation:		Stamp	
Service <input type="checkbox"/>			
..... <input type="checkbox"/>			
Anticorrosion check:			
OK <input type="checkbox"/> Not OK* <input type="checkbox"/>			
Date:	Miles (km):	Invoice number:	Comments/miscellaneous
Type of operation:		Stamp	
Service <input type="checkbox"/>			
..... <input type="checkbox"/>			
Anticorrosion check:			
OK <input type="checkbox"/> Not OK* <input type="checkbox"/>			

* See specific page

7

SERVICE SHEETS

VIN:

Date:	Miles (km):	Invoice number:	Comments/miscellaneous
Type of operation: Service <input type="checkbox"/> <input type="checkbox"/>		Stamp	
Anticorrosion check: OK <input type="checkbox"/> Not OK* <input type="checkbox"/>			
Date:	Miles (km):	Invoice number:	Comments/miscellaneous
Type of operation: Service <input type="checkbox"/> <input type="checkbox"/>		Stamp	
Anticorrosion check: OK <input type="checkbox"/> Not OK* <input type="checkbox"/>			
Date:	Miles (km):	Invoice number:	Comments/miscellaneous
Type of operation: Service <input type="checkbox"/> <input type="checkbox"/>		Stamp	
Anticorrosion check: OK <input type="checkbox"/> Not OK* <input type="checkbox"/>			

* See specific page

ANTICORROSION CHECK

If the continuation of the warranty is subject to repair, it is indicated below.

VIN:

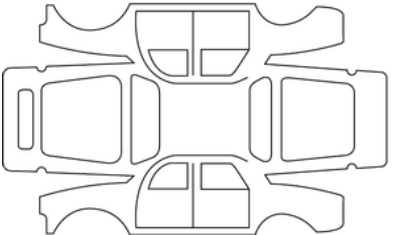
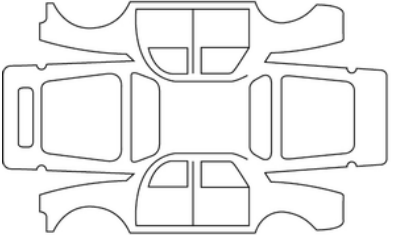
Date of repair:		Stamp
Corrosion repair operation to be carried out:		
Date of repair:		Stamp
Repair to be carried out:		

7

ANTICORROSION CHECK

If the continuation of the warranty is subject to repair, it is indicated below.

VIN:

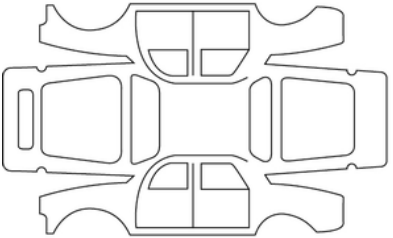
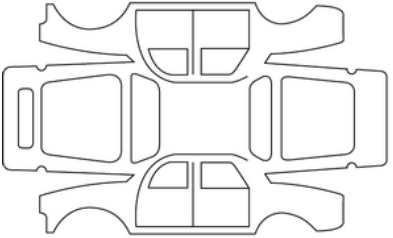
Date of repair:		Stamp
Corrosion repair operation to be carried out:		
Date of repair:		Stamp
Repair to be carried out:		

ANTICORROSION CHECK

If the continuation of the warranty is subject to repair, it is indicated below.

VIN:

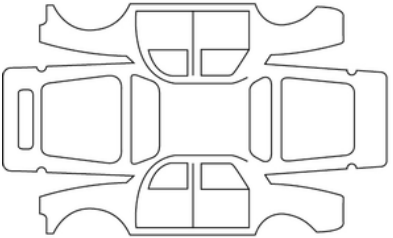
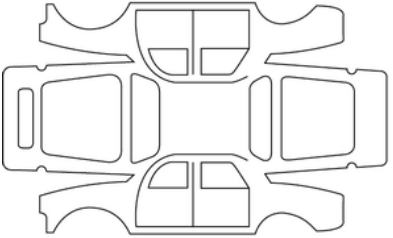
Date of repair:		Stamp
Corrosion repair operation to be carried out:		
Date of repair:		Stamp
Repair to be carried out:		

7

ANTICORROSION CHECK

If the continuation of the warranty is subject to repair, it is indicated below.

VIN:

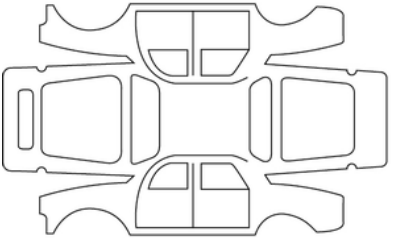
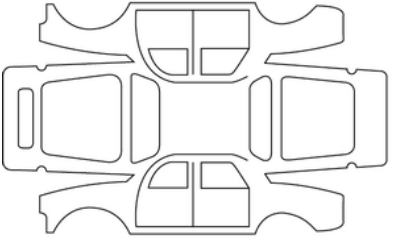
Date of repair:		Stamp
Corrosion repair operation to be carried out:		
Date of repair:		Stamp
Repair to be carried out:		

ANTICORROSION CHECK

If the continuation of the warranty is subject to repair, it is indicated below.

VIN:

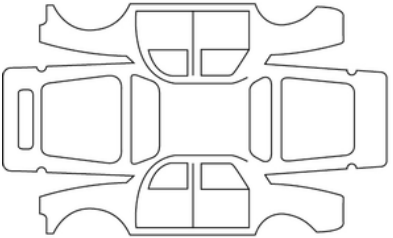
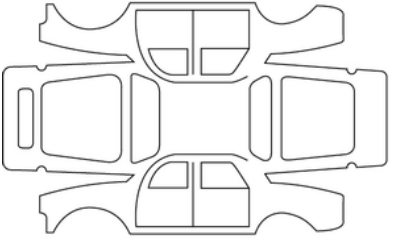
Date of repair:		Stamp
Corrosion repair operation to be carried out:		
Date of repair:		Stamp
Repair to be carried out:		

7

ANTICORROSION CHECK

If the continuation of the warranty is subject to repair, it is indicated below.

VIN:

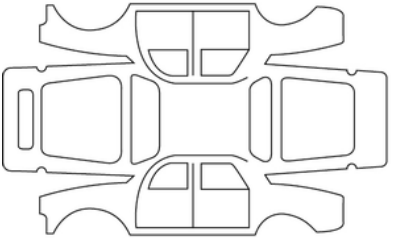
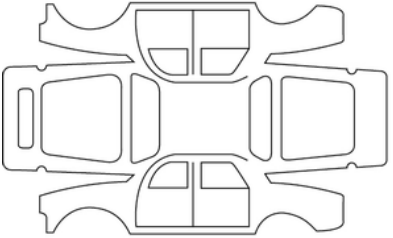
Date of repair:		Stamp
Corrosion repair operation to be carried out:		
Date of repair:		Stamp
Repair to be carried out:		

ANTICORROSION CHECK

If the continuation of the warranty is subject to repair, it is indicated below.

VIN:

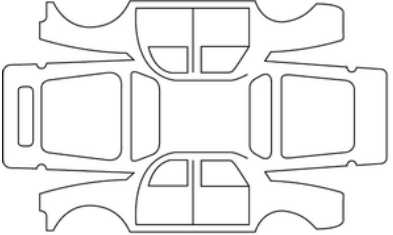
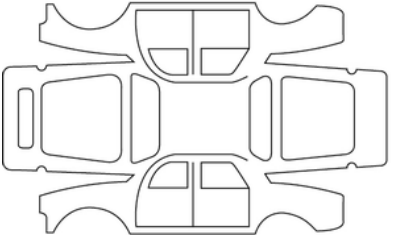
Date of repair:		Stamp
Corrosion repair operation to be carried out:		
Date of repair:		Stamp
Repair to be carried out:		

7

ALPHABETICAL INDEX

Symbols

« hands-free » card : battery, [35](#)

A

ABS, [162](#)

Accessories, [129](#)

Accessories socket, [261](#), [271](#), [271](#)

Access to the engine compartment, [280](#)

Access vehicle, [29](#), [31](#)

Adaptive cruise control, [208](#), [209](#)

Additional methods of restraint side protection, [59](#)

Additional methods of restraint to the front seat belts, [54](#)

Additional methods of restraint to the rear seat belts, [58](#)

Additional tank capacity, [91](#)

Adjusting your driving position, [44](#), [44](#), [48](#), [50](#), [113](#)

Advice on antipollution, [158](#)

Air bag, [54](#), [58](#), [59](#), [70](#), [72](#), [76](#), [78](#)

Airbag : activating the front passenger airbag, [78](#)

Airbag : deactivating the front passenger airbag, [78](#)

Air bag activating the front passenger air bags, [70](#), [72](#), [76](#), [78](#)

Air bag deactivating the front passenger air bags, [76](#), [78](#)

Airbags : child safety, [78](#)

Air conditioning, [252](#), [253](#), [255](#), [257](#)

Air conditioning: information and advice for use, [257](#)

Air vents, [252](#)

Air Vents, [251](#)

Anti-corrosion protection, [293](#)

Anti-lock braking system : ABS, [162](#)

Antipollution advice, [158](#)

Armrest : front, [44](#), [272](#)

Ashtray, [271](#)

Assisted parking, [221](#), [226](#), [229](#)

Audible and visual signals, [119](#), [119](#)

Automatic gearbox (use), [135](#), [138](#), [146](#)

Automatic gearbox breakdown recovery, [309](#)

Automatic gearbox selector lever, [135](#), [138](#)

AUTO mode, [113](#)

B

Batteries, [35](#)

Battery, [289](#), [291](#), [291](#), [311](#)

Battery: troubleshooting, [311](#)

Battery troubleshooting, [311](#)

Blinds, sun visor, [270](#)

Blind spot : warning signal, [172](#)

Blind spot warning signal, [172](#)

Bonnet, [280](#)

Brake, [149](#)

Brake fluid, [285](#)

Bulbs changing, [316](#), [319](#)

C

Card, [29](#), [31](#)

Card : battery, [35](#)

Card: emergency key, [29](#)

Card: engine not starting in hands-free mode, [29](#)

Card: hands-free, [29](#)

ALPHABETICAL INDEX

Card: locking/unlocking the opening elements, [29](#)

Card : use, [29](#), [31](#)

Catalytic converter, [144](#)

Central door locking, [29](#), [31](#), [39](#), [42](#), [105](#)

Changing a bulb, [316](#)

Changing a wheel, [307](#)

Changing gear, [135](#), [138](#), [151](#)

Children, [62](#), [70](#), [72](#), [76](#), [78](#), [264](#)

Children (safety), [38](#), [265](#)

Child restraint/seat, [62](#), [70](#), [72](#), [76](#)

Child safety, [29](#), [31](#), [38](#), [62](#), [62](#), [70](#), [72](#), [76](#), [78](#), [264](#), [265](#)

Child seats, [62](#), [68](#), [70](#), [72](#), [76](#)

Cigar lighter, [271](#)

Cleaning : inside the vehicle, [295](#)

Clock, [107](#)

Clock setting, [91](#)

Closing the doors, [29](#), [31](#), [38](#), [38](#), [39](#), [42](#)

Configuration menu, [105](#)

Control instruments, [91](#), [100](#), [107](#)

Controls, [202](#), [205](#)

Controls steering wheel, [261](#)

Coolant level, [285](#)

Courtesy light, [268](#), [319](#)

Courtesy mirrors, [270](#)

Cruise control, [205](#), [208](#), [209](#)

Cruise control-speed limiter, [202](#), [205](#)

Customised vehicle settings, [105](#)

Customising the vehicle settings, [105](#)

D

Daytime running lights, [29](#), [105](#), [113](#)

Demisting rear screen, [253](#), [255](#)

Demisting windscreen, [253](#), [255](#)

Dipstick, [281](#)

Display, [100](#), [100](#), [261](#)

Doors, [38](#), [38](#), [42](#), [105](#)

Doors/tailgate, [29](#), [31](#), [39](#), [42](#)

Doors and tailgate, [31](#)

Driver assistance, [162](#), [166](#), [166](#), [172](#), [176](#), [178](#), [187](#), [202](#), [205](#), [208](#), [209](#), [221](#), [226](#), [229](#), [234](#), [249](#)

Driving, [105](#), [127](#), [129](#), [135](#), [138](#), [144](#), [146](#), [149](#), [151](#), [162](#), [166](#), [166](#), [172](#), [176](#), [178](#), [202](#), [205](#), [208](#), [209](#), [221](#), [226](#), [229](#), [234](#), [249](#)

Driving aids, [105](#), [166](#), [166](#), [172](#), [176](#), [178](#), [187](#), [190](#), [202](#), [205](#), [208](#), [209](#), [221](#), [226](#), [229](#), [234](#), [243](#), [249](#)

Driving position, [81](#)

Driving position settings, [50](#), [109](#)

Driving recommendations, [151](#)

E

ECO driving, [151](#)

ECO mode, [151](#), [257](#)

Electric windows, [264](#)

Electronic parking brake, [146](#), [146](#), [149](#)

Electronic stability control : ESC, [162](#)

Electronic Stability Control : ESC, [162](#)

Emergency active braking, [178](#)

Emergency brake assist, [162](#)

ALPHABETICAL INDEX

Emergency braking, [162](#), [178](#)
Emergency key, [29](#)
Emergency spare wheel, [304](#), [304](#)
Engine coolant, [100](#), [285](#)
Engine identification, [334](#)
Engine oil, [281](#), [281](#), [282](#)
Engine oil capacity, [282](#)
Engine oil level, [100](#), [281](#), [281](#), [282](#)
Engine specifications, [334](#)
Engine standby, [131](#)
Engine start/stop button, [129](#)
Environment, [157](#)
ESC : electronic stability control, [162](#)
Exterior lighting and signals, [113](#)
Exterior lights, [316](#)
External temperature, [107](#)

F

Faults operating faults, [135](#), [138](#), [144](#), [146](#), [162](#), [166](#), [172](#), [178](#), [187](#), [221](#), [257](#), [264](#), [324](#)
File, [44](#)
Filter air filter, [285](#)
Filter oil filter, [282](#)
Filter particle filter, [144](#)
Filter passenger compartment filter, [285](#)
Fitting a child seat, [68](#)
Fittings, [272](#)
Front headrests, [44](#)
Front seat adjustment, [44](#)

Front seat adjustment electric controls, [44](#)
Front seats, [44](#)
Front seats adjustment, [44](#), [44](#), [50](#)
Fuel advice on fuel economy, [151](#)
Fuel consumption, [91](#), [151](#), [257](#)
Fuel economy, [151](#)
Fuel filler cap, [124](#)
Fuel filling, [124](#)
Fuel grade, [124](#)
Fuel level, [100](#), [124](#)
Fuel tank capacity, [124](#)
Fuses, [324](#), [324](#)

G

Gear control, [135](#)
Gear lever, [135](#), [138](#)
Grab handle, [272](#)

H

Handbrake, [146](#)
Hands-free telephone integrated control, [261](#)
Hazard warning lights signal, [119](#)
Headrest, [44](#), [48](#)
Headrest rear, [48](#)
Heated seats, [44](#)
Heated steering wheel, [109](#)
Heating and air conditioning system, [251](#), [253](#), [255](#), [257](#)
Heating system, [251](#), [253](#), [255](#)
Hill Start Assist, [162](#)

ALPHABETICAL INDEX

Horn, [119](#)
Horn : flash, [119](#)
Hubcap tool, [304](#)

I

Ignition switch, [146](#)
Indicators, [119](#), [172](#), [316](#)
Indicators : direction indicators, [119](#)
Indicators : instrument panel, [91](#), [100](#), [131](#), [144](#), [146](#), [149](#), [151](#), [158](#)
Instrument panel, [91](#), [100](#), [105](#), [131](#), [146](#), [149](#), [151](#), [158](#)
Instrument panel messages, [91](#), [131](#), [144](#), [146](#)
Interior lighting, [268](#)
Interior lighting: changing bulbs, [319](#)
Interior lighting : changing bulbs, [319](#)
Interior trim maintenance, [295](#)
Isofix, [76](#)

J

Jack, [304](#), [304](#), [307](#)

L

Lane centring, [190](#)
Lane departure warning, [166](#), [166](#)
Lane keeping: assistance, [166](#)
Lane keeping : assistance, [166](#)
Lane Keeping Assist, [166](#), [166](#)
Levels, [280](#), [285](#), [286](#)
Levels : brake fluid, [285](#)

Levels: coolant, [285](#)
Levels : coolant, [285](#)
Levels : windscreen washer reservoir, [285](#)
Lifting the vehicle changing a wheel, [307](#)
Lighting : exterior, [113](#), [119](#)
Lighting : instrument panel, [113](#)
Lighting : interior, [268](#), [319](#)
Lighting : see-me-home, [105](#), [113](#)
Lights : dipped beam headlights, [113](#), [316](#)
Lights : direction indicators, [119](#), [316](#)
Lights : fog lights, [113](#)
Lights : hazard warning, [119](#)
Lights : main beam headlights, [113](#), [316](#)
Lights: replacing bulbs, [316](#)
Lights : side lights, [113](#), [316](#)
Lights changing bulbs, [316](#)
Lights front, [316](#)
Lights-on warning buzzer, [113](#)
Locking, [50](#)
Locking/unlocking the doors, [39](#)
Locking/unlocking the opening elements map, [29](#)
Locking the doors, [29](#), [31](#), [38](#), [39](#), [42](#), [105](#)
Luggage compartment, [43](#)

M

Maintenance, [158](#), [257](#)
Maintenance : bodywork, [293](#)
Maintenance: filters, [286](#)
Maintenance : interior trim, [295](#)

ALPHABETICAL INDEX

Maintenance : mechanical, [281](#), [291](#), [291](#)
Maintenance : mileage before service, [91](#)
Manual air conditioning, [253](#)
Map hands-free, [31](#)
Map reading lights, [268](#), [319](#)
Menu for customising the vehicle settings, [91](#), [105](#)
Methods of restraint in addition to the seat belts, [54](#), [58](#), [59](#)
Mileage before service, [91](#)
Mobile floor, [276](#)
Motorway and Traffic assistant, [190](#)
Multimedia (equipment), [261](#)
Multimedia equipment, [100](#), [105](#), [107](#), [113](#), [261](#), [261](#)
Multimedia screen screens, [166](#)
Multi-Sense, [109](#), [249](#)
Multi-view camera, [234](#)

N

Navigation, [261](#)
Navigation system, [261](#)

O

Oil change, [282](#)
Opening elements, [38](#), [42](#)
Opening the doors, [38](#), [38](#), [39](#), [42](#)
Operating faults, [42](#), [44](#), [54](#), [78](#), [91](#), [113](#), [120](#), [129](#), [131](#), [135](#), [138](#), [144](#),
[146](#), [162](#), [166](#), [166](#), [166](#), [172](#), [178](#), [187](#), [208](#), [209](#), [221](#), [243](#), [257](#), [264](#),
[324](#)
Operating faults: card batteries, [29](#)
Operating faults card battery, [35](#)

Operation, [135](#), [138](#)
Overspeed buzzer, [100](#)
Overspeed warning, [187](#), [202](#)

P

Paintwork maintenance, [293](#)
Parking : parking aid, [243](#)
Parking assistance : assisted parking, [221](#), [226](#), [229](#)
Parking brake, [146](#), [146](#), [149](#)
Parking distance control, [105](#), [221](#), [221](#), [226](#)
Passenger safety: front passenger airbag, [78](#)
Pedestrian detection, [178](#)
Power-assisted steering, [109](#)
Power consumption, [100](#)
Precautions during use, [120](#)
Pretensioners, [54](#)
Puncture, [303](#), [304](#), [304](#), [304](#), [307](#)
Puncture: emergency spare wheel, [304](#)

R

Radio, [261](#)
Range with fuel, [100](#)
Rear headrests, [48](#)
Rear parcel shelf, [277](#)
Rear seats, [48](#), [48](#), [50](#)
Rear view camera, [226](#)
Rear view mirrors, [109](#), [111](#)
Remote control, [31](#)
Remote control card, [29](#)

ALPHABETICAL INDEX

Remote control map, [29](#)
RENAULT ANTI-INTRUDER DEVICE (RAID), [42](#)
Replacement and repair parts, [339](#)
Replacing windscreen wiper blades, [322](#)
Reversing camera, [226](#)
Reversing sensor, [221](#)
Roof bars, [278](#), [278](#)
Roof rack roof bars, [278](#)
Running in, [127](#), [127](#)

S

Safety distances, [176](#)
Safety distance warning, [176](#)
Screen navigation display, [261](#)
Screen navigation screen, [261](#)
Screens multimedia screen, [151](#), [166](#), [172](#), [176](#), [178](#), [187](#), [221](#), [226](#),
[229](#), [234](#), [243](#), [249](#), [261](#)
Screen wash/wipe, [120](#)
Screen wash/wipe replacing blades, [120](#), [322](#)
Seat belt pretensioners, [58](#)
Seat belt pretensioners front seat belt, [54](#)
Seat belts, [50](#), [50](#), [54](#), [70](#), [72](#), [76](#), [295](#)
Seats front seat with electric controls, [44](#)
Settings, [105](#)
Settings configuration menu, [105](#)
Shift Paddle, [135](#), [138](#)
Side protection devices, [58](#), [59](#), [59](#)
Signals and lights, [113](#), [119](#)
Sign detection : overspeed warning, [187](#)

Special features of petrol vehicles, [144](#)
Speed limiter, [202](#)
Spoiler, [278](#)
Starting the engine, [128](#), [129](#), [131](#)
Steering wheel adjustment, [109](#)
Steering wheel controls, [261](#)
Stop & Start, [109](#), [124](#), [149](#), [151](#)
Stop & Start function, [131](#), [146](#), [149](#), [151](#)
Stopping the engine, [128](#), [129](#), [146](#)
Storage compartment, [272](#)
Storage compartment/fittings: passenger compartment, [272](#)
Storage compartments, [272](#)
Sunroof, [265](#)
Sun visor, [270](#)
Switching on the vehicle ignition, [129](#)

T

Tailgate, [29](#), [38](#), [39](#), [43](#), [276](#)
Tanks and reservoirs : windscreen washer, [285](#)
Tanks and reservoirs brake fluid, [285](#)
Tanks and reservoirs coolant, [285](#)
Telephone, [261](#)
Temperature regulation, [255](#)
Tool kit, [304](#), [304](#)
Tools, [304](#)
Towing breakdown, [309](#)
Towing hitch, [304](#), [309](#)
Towing rings, [276](#)
Traction control, [162](#)

ALPHABETICAL INDEX

Traction control system : ASR, [162](#)
Transporting children, [62](#), [70](#), [72](#), [76](#)
Trip computer, [91](#)
Trip computer and warning system, [91](#), [100](#), [105](#)
Troubleshooting: battery, [311](#)
Tyre inflation kit, [303](#), [304](#)
Tyre pressure, [91](#), [297](#), [299](#), [299](#), [303](#), [304](#), [307](#)
Tyre pressure loss warning, [303](#), [307](#)
Tyre pressures, [297](#), [299](#), [303](#), [307](#)
Tyres, [297](#), [297](#), [299](#)

U

Unlocking the doors, [29](#), [31](#), [39](#), [42](#)
USB socket, [261](#)

V

Variable power-assisted steering, [109](#)
Vehicle detection, [178](#)
Ventilation, [252](#), [253](#), [255](#)
Ventilation ventilation, [252](#)

W

Warning lights, [91](#), [100](#)
Washing, [293](#)
Wheelbrace, [304](#), [307](#)
Wheels (safety), [297](#)
Windscreen de-icing/demisting, [253](#), [255](#)
Windscreen washer, [120](#)

Windscreen washer/wiper, [105](#), [322](#)
Wiper, [120](#)
Wiper blades, [120](#), [322](#)
Wiper blades: replacement, [322](#)
Wipers, [120](#)
Wireless charger, [261](#)

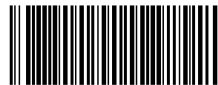

7711416784

